

*F. W. Weiss.*

*Combined Cloak & Mattress.*

*No 2906  
33910*

*Patented Dec. 10. 1861.*

*Fig. 3.*

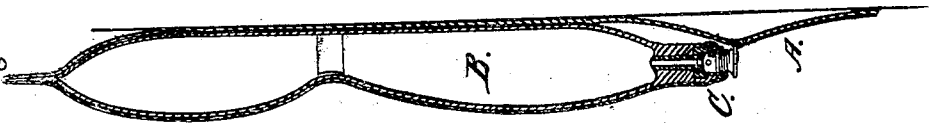

*Fig. 2.*

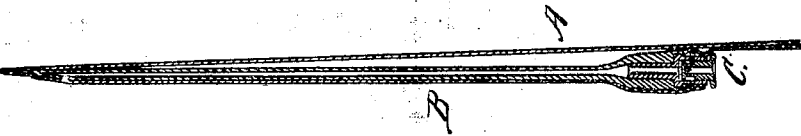

*Fig. 1.*

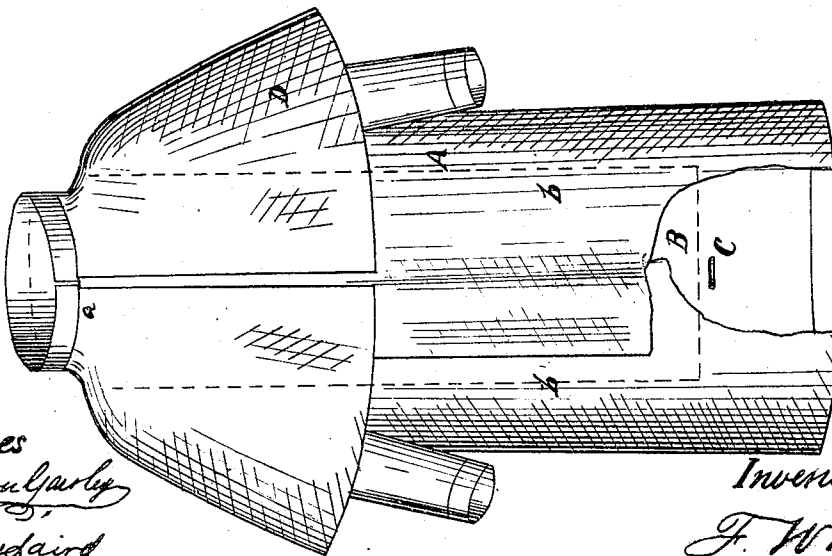

*Witnesses  
Richardson & Garby  
James Laird*

*Inventor  
F. W. Weiss*

# UNITED STATES PATENT OFFICE.

F. W. WEISS, OF MOUNT VERNON, NEW YORK.

## IMPROVEMENT IN MILITARY CLOAKS.

Specification forming part of Letters Patent No. 33,910, dated December 10, 1861.

*To all whom it may concern:*

Be it known that I, F. W. WEISS, of West Mount Vernon, in the county of Westchester and State of New York, have invented a new and Improved Military Cloak or Overcoat, the same being a combination of a cloak or coat and mattress or bed; and I do hereby declare that the following is a full, clear, and exact description of the same, reference being had to the accompanying drawings, making a part of this specification, in which—

Figure 1 is an elevation of my invention shown as a cloak or coat; Fig. 2, a vertical or longitudinal section of the back of the same; Fig. 3, a longitudinal section of the same, shown as a mattress or bed.

Similar letters of reference indicate corresponding parts in the several figures.

The object of this invention is to combine a cloak or overcoat and mattress or bed in such a manner that the device, when used as a cloak or coat, may be worn, as usual, and possess all the advantages of the ordinary military cloak or coat and be capable when required of being readily converted into a mattress or bed with suitable covers for the occupant, enabling him to sleep in the open air without a tent. It is designed, also, that the invention be capable of being used as floats in the construction of temporary or flying bridges, and also to serve, when necessary, as floats to enable the soldiers individually to pass over moats of fortifications and like places in perfect safety, each cloak or coat, when inflated, forming a float for its wearer.

The invention consists in having a cloak or coat constructed of india-rubber, cloth, or other suitable fabric in the usual or other proper form, the cloak or coat being provided with an air bag or compartment in its back, which is inflated when the device is used as a mattress or float, the air being allowed to escape when the device is used as a cloak or coat.

To enable those skilled in the art to fully understand and construct my invention, I will proceed to describe it.

A represents a cloak or overcoat, which may be constructed of india-rubber, cloth, or other suitable material. This cloak or coat

may be of the form and style usually made for soldiers, as shown in Fig. 1.

At the back of the cloak or coat there is a wind-bag or air-tight compartment B, which extends from the collar *a* of the cloak or coat downward to nearly its lower end, and is equal in width to the back of the coat or cloak. This bag or compartment B may be of india-rubber or other suitable material and fitted in the lining of the coat or cloak. This bag or compartment, when not inflated, is perfectly flat and does not in the least increase or augment the proper size of the coat or cloak. The bag or compartment B is provided at its lower end with a screw mouth-piece C, by means of which the bag or compartment B may be inflated by the wearer at any time.

When the bag or compartment B is inflated, a mattress or bed is obtained, and the front parts *b b* of the cloak or coat serve as a covering therefor. The cape D of the cloak or coat may be made to protect the head of the occupant, who will be perfectly shielded from the weather. The upper part or head of the mattress or bed may be elevated by placing the knapsack under it. The mattress or bed is sufficiently large to serve as a float to sustain the wearer or owner on the water, and hence the device will prove very serviceable to an army in crossing rivers, the moats of fortifications, &c., as each soldier can in a moment of time convert his cloak or coat into a float and propel himself across the stream or moat without difficulty or danger. A number of inflated cloaks or coats may also be used as floats in the construction of flying or temporary bridges, and enable bridges of this kind to be rapidly constructed for the passage of an army over rivers.

The invention will also prove valuable for soldiers on picket-service, as they can rest upon a comfortable mattress or bed without exposure to the weather and be perfectly protected from the earth, which is very desirable, as much sickness is caused by soldiers lying on the damp earth or upon a blanket in direct contact therewith.

This invention has been practically tested, and it has been found that the cloak or coat

does not weight but two and one-half pounds more than the ordinary cloak or coat now in use, and that it will sustain or buoy up the wearer or owner with fifty pounds surplus weight quite easily.

Having thus described my invention, what I claim as new, and desire to secure by Letters Patent, is—

The construction of a military cloak or a

military coat in the manner described, so as to be capable of conversion at will into an air bed or mattress, substantially as above set forth.

F. W. WEISS.

Witnesses:

RICHARDSON GAWLEY,  
JAMES LAIRD.