

DECLARATION IN SUPPORT OF A CONVENTION
APPLICATION FOR A PATENT

In support of the Convention application made for a patent for an invention entitled PROCESS AND DEVICE FOR CONTROLLING THE ADMISSION OF A MEDIUM INTO AT LEAST ONE LEAKAGE-CHAMBER OF A VALVE DEVICE

I, Hans-Otto MIETH,

of Sandkrug 3, D-2058 Schnakenbek, West Germany

do solemnly and sincerely declare as follows: -

1. I am the applicant for the patent

(or, in the case of an application by a body corporate)

~~I am authorized by _____, the applicant
for the patent to make this declaration on its behalf.~~

2. The basic application as defined by section 141 of the Act was made in of Germany on the 20th day of January, 19 88, by Hans-Otto MIETH

3. I am the actual inventor of the invention referred to in the basic application.

(or, where a person other than the inventor is the applicant)

of

~~is the actual inventor of the invention and the facts upon which I am entitled
is entitled to make the application are as follows: -~~

4. The basic application referred to in paragraph 2 of this Declaration was the first application made in a Convention country in respect of the invention the subject of the application.

(or, where a request is made under section 142AA of the Patents Act 1952, for an earlier application made in a Convention country to be disregarded)

~~(1.) The basic application referred to in paragraph 2 of this Declaration was not the first application made in a Convention country in respect of the invention the subject of the application.~~

~~(2.) An earlier application in respect of the invention the subject of the application was made in _____ on _____~~

~~(3.) A request has been made to you under section 142A of the Patents Act 1952 to disregard that earlier application.~~

~~*(Here set out in succeeding sub-paragraphs the facts that show that section 142AA is applicable)*~~

Except as stated in this paragraph, the basic application referred to in paragraph 2 of this Declaration the first application made in a Convention country in respect of the invention the subject of the application.

Declared at Hamburg this 21st day of August, 19 89

(Signature of Declarant)

(Hans Otto Mieth)

TO

THE COMMISSIONER OF PATENTS.

(IMPORTANT Cross out inapplicable words in above Form.)

(11) AU-B-30354/89
(10) 623376

-2-

said casing parts, said shutter means comprising at least one shutter member having a through passage, said shutter member selectively engaging one of said first and second sealing means to thereby provide said fluid communication between one of said pairs of adjacent casing parts, and said closing means selectively engaging the other of said first and second sealing means to block fluid communication between the other of said pair of adjacent casing parts, said closing means and said shutter means comprising means for selectively isolating said leakage cavity from the remainder of the inner space of said casing.

PCT

ANNOUNCEMENT OF THE LATER PUBLICATION
OF INTERNATIONAL SEARCH REPORTS



30354/89

INTERNATIONALE ANMELDUNG VEROFFENTLICHT NACH DEM ÜBERTRAG ÜBER DIE
INTERNATIONALE ZUSAMMENARBEIT AUF DEM GEBIET DES PATENTWESENS (PCT)

<p>(51) Internationale Patentklassifikation 4 : F16K 11/07, 37/00, 25/02</p>	<p>A3</p>	<p>(11) Internationale Veröffentlichungsnummer: WO 89/ 06764 (43) Internationales Veröffentlichungsdatum: 27. Juli 1989 (27.07.89)</p>
<p>(21) Internationales Aktenzeichen: PCT/EP89/00045 (22) Internationales Anmeldedatum: 17. Januar 1989 (17.01.89) (31) Prioritätsaktenzeichen: P 38 01 569.2 (32) Prioritätsdatum: 20. Januar 1988 (20.01.88) (33) Prioritätsland: DE (71)(72) Anmelder und Erfinder: MIETH, Hans-Otto [DE/DE]; Sandkrug 3, D-2058 Schnakenbek (DE). (81) Bestimmungsstaaten: AT (europäisches Patent), AU, BE (europäisches Patent), BR, CH (europäisches Patent), DE (europäisches Patent), DK, FI, FR (europäisches Patent), GB (europäisches Patent), IT (europäisches Patent), JP, KR, LU (europäisches Patent), NL (europäisches Patent), NO, SE (europäisches Patent), SU, US.</p>		<p>Veröffentlicht <i>Mit internationalem Recherchenbericht. Vor Ablauf der für Änderungen der Ansprüche zugelassenen Frist Veröffentlichung wird wiederholt falls Änderungen eintreffen.</i> (88) Veröffentlichungsdatum des internationalen Recherchenberichts: 24. August 1989 (24.08.89)</p>

623376

(54) Title: PROCESS AND DEVICE FOR CONTROLLING THE ADMISSION OF A MEDIUM INTO AT LEAST ONE LEAKAGE CHAMBER OF A VALVE DEVICE

(54) Bezeichnung: VERFAHREN ZUR STEUERUNG DES MEDIUMEINTRITTES IN WENIGSTENS EINEN LECKKAMERAUM EINER VENTILVORRICHTUNG UND VORRICHTUNG ZU SEINER DURCHFÜHRUNG

(57) Abstract

A process is useful for controlling the admission of a medium into at least one leakage chamber of a valve device described in the preamble of claim 1. The process makes it possible to obtain a multiple-way reversing valve of novel design whose reversing functions and properties, in particular the leakproofness of each seat part, are novel. For this purpose, in the position of the valve which differs from its starting position with respect of the reversed valve seat, the closing slide valve which separates the leakage chamber from the inner chamber replaces the closing member which exercises the same function in the starting position, and vice versa.

(57) Zusammenfassung

Die Erfindung betrifft ein Verfahren zur Steuerung des Mediemeintrittes in wenigstens einen Leckkammer einer Ventilvorrichtung nach dem Oberbegriff des Anspruchs 1. Durch das vorgeschlagene Verfahren wird in Anwendung auf ein Mehrwege-Umschaltventil, das an sich in seinem Aufbau schon neu ist, eine Ventilvorrichtung geschaffen, die hinsichtlich der gegebenen Schaltfunktionen und seiner Eigenschaften, insbesondere der Leckagesicherheit jedes einzelnen Sitzbereiches, neu ist. Dies wird unter anderem verfahrenstechnisch dadurch erreicht, daß in der von der Grundstellung abweichenden Stellung der Ventilvorrichtung am jeweils umgeschalteten Ventilsitz eine Substitution des den Leckkammer von dem Innenraum jeweils absperrenden Schließgliedes bzw. Verschlussteils durch das jeweils andere vorgesehen wird.

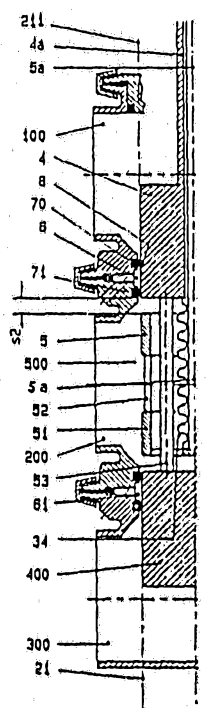

Process for controlling the medium inlet into at least one leakage cavity of a valve and an apparatus for its performance

The invention relates to a process for controlling the medium inlet into at least one leakage cavity of a valve according to the opening portion of claim 1 and an apparatus for its performance.

The state of the art known so far in the field of the so-called leak-proof polyway-switching valves can e.g. be gathered from DE-PS 20 27 792. In the cleansing position and/or the sterilizing position this valve satisfies (cp. column 5, lines 40 et seq.) the minimum requirement to be met, namely that there must exist, at any time, at least two seals between the filling material to be packed and e.g. a cleansing agent for the vessels, and that the space between the seals is to be rinsed with a cleansing agent. In analogy with field of pneumatics the known valve constitutes a so-called 4/2-way valve, since it is provided with four connections (three casing connections, one leakage cavity connection) and two switching positions. There is not given a normal position in which the valve, as seen from the middle valve casing part, is either open or closed at both sides. From Fig. 2 of the above cited reference it is furthermore evident that in the illustrated filling position of the valve there exists only a simple sealing between the middle valve casing part 3 and the lower valve casing part 4. While in this position product is transferred from the upper valve casing part 2 to the middle valve casing part 3, pressurized cleansing agent can basically stand in line in the lower valve casing part 4. In this case a defective sealing in the lower seat region or an impact of pressure from the lower valve casing part 4 would lead to a mixing of product and cleansing agent, since the lower seat region is not protected against leakage.



German patent application P 37 01 027.1 furthermore describes a valve with a leakage cavity, which is provided with two sealing places disposed in series and in the closed position of the valve prevents the overflow of fluids from one valve casing part into another. There the leakage cavity is disposed between the sealing places and connected with the environment of the valve via the valve casing. With this so-called double seat valve the technical problem is solved to control the inlet also in other positions of the valve, in addition to the control of the medium inlet known per se from the inner space to the leakage cavity in the closed position of the valve. The solution of the procedural problem is achieved in that the connection between the leakage cavity and the inner space in positions other than the closed position of the valve is controlled with the same effect and in the same manner as in the closed position by means of an arrangement substituting the closing member concerning its interaction with the leakage cavity. With view to the concrete realization there is inter alia provided a locking element which with respect to the closing member is disposed in relatively mobile relation in the direction of the degree of its freedom of motion and controls the connection between the leakage cavity and the inner space of the valve casing parts. In the course of this, at least in the open position of the valve, the locking element is in permanent contact with the two sealing places, these being realized by sealing means disposed on the side of the valve casing or on the side of the closing member or the locking element, respectively.

From the above mentioned German patent application there is also known a sealing arrangement comprising two separate seals disposed on the side of the valve casing; in the Euro-PCT-application (WO 88/05512) claiming the priority of said German patent application these two discrete seals inter alia are seals with annular cross section.



Starting out from the prior art shown it is the problem of the invention to create a process for the control of the medium inlet into at least one leakage cavity of a valve, wherein the valve comprises more than two valve casing parts with feed and drain casing parts and in particular has controllable connections between leakage cavity and inner space of the valve casing.

The problem is solved by applying the characterizing features of claim 1 or 2, wherein the process according to the invention provides the valve with switching functions and properties which are novel and advantageous.

Advantageous embodiments of the valve for performing the above mentioned process are described in subclaims 3 to 12. It is revealed that there a valve is proposed the structure of which was unknown so far.

With the proposed invention it is possible to realize a complex valve with three valve casing parts, five connections and three switching positions. When designing a specific seat region with one leakage cavity opening between two seals this results in a novel assembly unknown hitherto with which a switching function becomes possible which was unknown so far to be realizable with known valves of this structure, namely the simultaneous closing position of the two outer valve casing parts with respect to the middle casing, and wherein additionally one leakage cavity each is provided between two adjacent valve casing parts. In analogy to the classification of valves in the technology of pneumatics this novel valve constitutes a so-called 5/3-way valve. Such a valve comprises five connections and 3 positions (A, B, C). In the middle position A, the so-called normal position, and depending on the dimension of the closing members the middle valve casing part can be closed or open on both sides, respectively, with respect to the outer valve casing parts. In the two other



positions B and C there results a switching function between the middle valve casing part and the respective connected outer valve casing part. The connection of the middle valve casing part and of the outer valve casing parts is identified with 1, 2 and 4 in accordance with the known nomenclature, while two further connections are designated 3 and 5. From the table shown below it can be seen which switching position is assumed by the respective connections 1 to 5 in the positions A, B and C. A closed connection is designated with "0", an open connection with "1".

Switching states of a 5/3-way valve
according to the state of the art

Connection	P o s i t i o n		
	A	B	C
1	0	1]	1]
2	0/1]	[1	1]
3	0/1]	[1	0
4	0/1]	1]	[1
5	0/1]	1	[1

*/**

* closed in normal position A

** open in normal position A

From the above table it becomes evident that such valves exist "closed" in the normal position or "open" in the normal position (cp. column A).

It furthermore becomes evident which connections of the 5/3-way valve are connected to each other in the B-position or in the C-position.

In the subject matter of the application, which, as already explained above, is a 5/3-way valve in view of the number of connections and switching positions, each of connections 3 and



5 constitutes the connection of the leakage cavity to the inner space of the valve casing. According to the invention this connection is always closed, in the closed position as well as in the open position of the valve. The table shown below exhibits the switching states of the subject matter according to the invention in analogy to the nomenclature known from pneumatics.

Switching states of the valve
according to the invention

Connection	P o s i t i o n		
	A	B	C
1	0/1]	1]	1]
2	0/1]	0]	1]
3	0	0	0
4	0/1]	1]	0
5	0	0	0

*/**

* closed in normal position A

** open in normal position A

From the above table it is evident that in the valve according to the invention the connections 1, 2 and 4 (connection 1 for the middle valve casing part; connections 2 and 4: connection for the respective outer valve casing parts) are switched in the same manner as in the 5/3-valve according to the state of the art. In position B connection 1 is switched through to connection 4, and in position C connection 1 is switched through to connection 2. Identity between the two solutions furthermore occurs in the switch position "closed in normal position". While in the 5/3-way valve according to the state of the art in position B connection 2 is connected with connection 3, and in position C connection 4 is connected with



connection 5, in the valve according to the invention connections 3 and 5 (connection of the leakage cavity to the inner space of the valve casing) always remain closed also in these positions.

When comparing the two valves with respect to the embodiment "normal position open" no concurrence will be found. While connection 1 in the valve according to the state of the art remains closed and connections 2 and 3 or 4 and 5 are connected to each other, it is evident from the subject matter according to the invention that there connections 1, 2 and 4 are connected to each other, while the connections of leakage cavities 3 and 5 are, as intended, in closed position.

From the last mentioned table it becomes evident that the valve proposed according to the invention constitutes a 5/3-way valve, which is not available in this configuration and with the above-mentioned properties in the field of valves, in particular in the field of the food and beverage industry. Apart from the function as switching valve there exists a normal position in which the valve is either closed or open. Furthermore the valve is leakproof in each seat region.

Starting out from the requirements for the actual use either both the leakage cavities or one of the two leakage cavities can be dispensed with in accordance with an embodiment of the valve according to the invention comprising three valve casing parts. Thus there is achieved a polyway-switching valve without or with only one leakage-safeguard in one of the two seat regions between adjacent valve casing parts. For the case that in one seat region the leakage cavity is omitted, the locking element will substitute the closing member with view to its interaction with the seal.

The valve proposed according to the invention when applied to the problem of the above-mentioned publication DE-PS 20 27 792



can easily be changed to a so-called 5/2-way valve by dimensioning the closing member correspondingly and omitting the normal position, and lead to a solution wherein also the lower valve seat is leakproof.

While already the omission of the normal position in the valve according to invention leads to a 5/2-way valve meeting the above requirements, it is possible in contrast to the known valve to modify the valve according to the invention to a real 5/2-way valve by dimensioning the length of the closing member accordingly, since it is easily possible to dimension the valve thus that on the one hand the closing member assumes a closed position before giving up the closed position on the other hand. In any case, in a switching run of the known poly-way-switching valve an intermediate position must be accepted wherein the middle casing part 3 is simultaneously connected with the two outer valve casings 2 and 4.

In the valve proposed according to the invention the connection element(s) can be disposed between the two closing members. Alternatively there is also feasible a solution where there is at least one locking element each on both sides of a single closing member. In the first mentioned case closing members as well as the locking elements can be connected to each other, so that in an unrestricted function of the valve merely two drive motions from outside are necessary. In the second case the same advantages are obtained regarding the design of the drive of such a valve.

While the above-mentioned valve allows unrestricted, leakage-free switching, a further embodiment of the valve according to the invention makes it possible to switch the valve with only one single drive motion, however, dispensing with leakage-free switching, i.e. tolerating a restricted switching leakage. This is achieved in that the locking elements are fixedly connected with the closing member in spaced relation.



A further embodiment of the valve according to the invention proposes to combine the locking elements when disposed at the inside and between the closing members to one locking element unit, which is displaced via a bar in relatively mobile relation to the closing member, the passage of which bar through the closing member can be bridged material closed in simple manner and under favorable conditions by means of a bellows.

Another embodiment of the valve according to the invention provides that in its axial extension the closing member is modified by arrangements operating like a telescope, the distance between the closing members being bridged material closed by a flexible connection element. Through this measure it becomes possible to furnish the valve with an ambivalent normal position, namely the normal position "closed" or the normal position "open". The largest axial extension of the closing member in the normal position of the valve is to be dimensioned such that the closing member covers both seat regions including the total respective leakage cavities.

In its shortest axial extension the valve in its normal position is open on both sides as seen from the middle valve casing part.

When using the valve according to the invention a further, not unimportant advantage occurs if e.g. a tank discharge is connected to the middle casing part and the outer valve casing parts are connected with conduits. While with the conventional assemblies of polyway-switching valves all regions of the polyway-switching valves in contact with the product were reached only if either both or at least the further off conduit was charged with cleansing agent from the tank, all regions of the valve proposed according to the invention are already reached when one of the two conduits is cleaned from the tank.



Examples of embodiments of the invention are illustrated in the drawing and explained in detail hereinafter.

There are shown in:

Figs. 1 to 3

in simplified schematic illustration a center section through the valve according to the invention in the three switching positions possible (Fig. 1: in normal position A closed; Fig. 2 and Fig. 3: the two other open positions B, C), with a single locking element being disposed at the inside of the two closing members;

Figs. 4 to 6

a center section through another embodiment of the valve according to the invention, also in the three switching states possible, wherein two locking elements are disposed at the inside of the two closing members and wherein a fixed connection of all locking elements and closing members to each other is provided;

Figs. 7 to 9

a center section through a further advantageous embodiment of the valve according to the invention in the three switching states possible, wherein the locking elements and the closing members with respect to number and arrangement correspond to the embodiment according to Figs. 4 to 6, however, a relative mobility between locking elements and closing members being given;

Figs. 10 to 12

a further center section through an embodiment of the valve according to the invention in the three switching states possible, wherein the locking elements are disposed at both sides of a single closing member and firmly connected thereto;



Figs. 13 to 15

a center section through a further advantageous embodiment of the valve according to the invention in the three switching states, as resulting from Figs. 10 to 12, wherein there is provided a relative mobility of the locking elements with respect to the closing member;

Fig. 16 and Fig. 17

in a substantially simplified, schematical illustration a center section through another embodiment of the means according to the invention in its normal position, wherein the axial extension of the closing member can be modified in a telescope-like manner (Fig. 16: closing members arranged outside the locking elements; Fig. 17: closing member arranged inside the locking elements).



List of designations

100, 200, 300	Valve casing parts
2a/2a1	Drain outlet
3	Casing closing part
4/400/401	Closing member
4a/400a	Bar
4b/400a	Apertures
4c/400c	Connection bridges
402	First closing member element
403	Second closing member element
404	First telescopic bar
405	Second telescopic bar
406	First flexible connection element
408	First guide bore
409	Second guide bore
5/51	Locking element
501/500	Locking element unit
5a	Bar
5b/51b	Bridges
5c/51c	Passage opening
52	First connection element
53	Second connection element
54	Second passage opening
6/61	Leakage cavity
70/701	First seal
71/701	Second seal
8/81	First sealing place
9/91	Second sealing place
12	Casing seal
13	Connection means
15/151	Connection port
16/161	Channel
18/181	Collection channel
21/211	First compensation piston
26/261	First bellows
34	Bellows



I/I1	Inlet of the cleansing fluid
II/III	Drain of the cleansing fluid
	Leakage
V/V1	Passage or pipe flow



Fig shows a valve with a locking element 5 disposed inside between the two closing members 4 and 400. The valve with the three casing parts 100, 200 and 300 is in its normal position A, in which it is closed on both sides as seen from the middle valve casing part 200.

In Figs. 2 and 3 the two open positions B and C of the valve are shown, wherein in Fig. 2 the upper closing member is in its open position and locking element 5 substitutes the position assumed by the closing member in the closed position with view to seals 70 and 71. The lower closing member 400 is dimensioned such that in the switching position shown it has not yet left the lower seat region with seals 701 and 711.

In Fig. 3 the lower closing member 400 is in its open position, the sole locking element 5 has substituted the position of the closing member in its closed position with view to seals 701 and 711. Thereby the upper closing member 4, in the same manner as the lower one, is dimensioned such that valve casing parts 100 and 200 are still sealed against each other. In each case the seals 70 and 71 or 701 and 711 are defined either by closing member 4 or 400 or by locking element 5. Between seals 70 and 71 there is leakage cavity 6 and between seals 701 and 711 there is leakage cavity 61. By the kind of hatching in Figs. 1 to 3 it is indicated that in each of the switching states shown closing members 4 and 400 have the same distance from each other, so that it is possible to connect and actuate them via one single bar (not shown) advanced from outside the valve. Locking element 5 requires its own drive, the necessary switching stroke of which is shorter than that for the closing members. Locking element 5 with its passage opening 5c allows the passage of flow V, above called "inner passage", from the middle casing part 200 to the upper casing part 100 or vice versa.

In the position of locking element 5 as shown in Fig. 3 the respective passage flow via the passage opening 5c is designated V1. Structure and function of the remaining structural



elements in the area of the valve casing parts 100 and 200 are known from German patent application P 37 01 027.1 and from the Euro-PCT-Application WO 88/05512 claiming the priority of the afore-mentioned patent application. This is particularly true for a casing closing part 3, a casing seal 12 and a connection means 13, a first and a second sealing place 8 and 9, respectively, a connection port 15, a channel 16 and a collection channel 18, a drain outlet 2a, from which the cleansing liquid or leakage designated with II penetrates. The inlet of the cleansing liquid via connection port 15 is designated with I.

The seat region provided between valve casing parts 200 and 300 is completely identical to that between valve casing parts 100 and 200. As distinguished from the equal parts in the upper seat region, the parts in this seat region are designated by adding the numeral 1 to the designations as known from the above patent applications (P 37 01 027.1; WO 88/05512). A description of the lower region of the known valve therefore is dispensable.

Nevertheless the valve illustrated in Figs. 1 to 3 does not simply represent a cumulation of two valves known per se from the above-mentioned patent applications. Apart from the fact that already the combination of the two valves known per se, as already explained above, forms a completely new valve, the substantial difference over the mere combination resides in that there are provided one single locking element 5 only and closing members 4 and 400 coupled to one another, due to which the complex valve can manage with merely two different drive motions, which are generated by means not shown.

In Figs. 4 to 6 there is shown another embodiment of the means according to the invention in the three switching states possible, the latter corresponding to those of Figs. 1 to 3. Valve casing parts 100, 200 and 300 and the pertinent



structural parts are identical with those according to Figs. 1 to 3. Therefore a complete enumeration with reference numerals was dispensed with in these and the subsequent figures. Although elements 4 and 400, 6 and 61, 8 and 81, 9 and 91, 70 and 701, 71 and 711 are still identified in detail they need not be referred to once more with respect to their purpose since they were already explained in the description of Figs. 1 to 3. In contrast to the embodiment according to Figs. 1 to 3 a second locking element 51 is provided in addition to locking element 5 in the embodiment according to Figs. 4 to 6. By way of example locking element 5 is firmly connected with closing member 4 via a connection bridge 4c and locking element 51 is firmly connected with closing member 400 via a connection bridge 400c, each at a distance s1. Since the upper closing member 4 in turn is fixedly connected with the lower closing member 400 via a bar 400a, the illustrated valve can be switched by means of a single drive motion, which is generated by means not shown. The switching movement from the closed to the open position, however, is not performed leakage-free, since between the locking element and the closing member 5, 51 or 4, 400 the above mentioned distance s1 exists. Apart from their connecting function, it is a task of connection bridges 4c and 400c to fix the respectively associated seals 70, 71 or 701, 711 in their necessary positions, during the switching movement from the closed to the open position or vice versa. In the open position as shown in Fig. 5 the passage flow designated V flows from the valve casing part 200 via passage opening 5c and the openings 4b into the upper valve casing part 100. In the other open position as shown in Fig. 6 the passage flow V1 flows in corresponding manner via a passage opening 51c and openings 400b formed between the connection bridges 400c, from the middle valve casing part 200 into the lower valve casing part 300 or vice versa. The interrupted lines 21 and 211 characterize possible compensation pistons with which the valve can be equipped and



which take care of a complete pressure compensation at closing member 4, 400.

In the embodiment according to Figs. 7 to 9 the same designations are used as in the embodiment according to Figs. 4 to 6, and the structural elements designated such are of identical structure and function. In the following description of the figures therefore reference is made only to the differences in the embodiments. The two closing members 4 and 400 are connected to one another at least via one second connection element 53 disposed eccentrically. The drive of the upper closing member 4, and thus also of the lower closing member 400, is produced via a bar 4a, which is a hollow bar. A bar 5a, connected with a locking element unit 500, is guided in said hollow bar. Said locking element unit 500 consists of the two locking elements 5 and 51, which in turn are firmly connected to one another by means of a first connection element 52. The locking element unit 500 is disposed in relatively mobile relation with respect to the closing members 4, 400 and can be displaced by a total of the two-fold distance s_2 . Said two-fold distance s_2 results from an aperture cross section corresponding approximately to the nominal cross section of the valve, the aperture cross section being formed in the respective open positions of the valve between the locking element 5 or 51 and the respectively associated closing member 4 or 400. A penetration gap, which is not defined in more detail, formed between bar 5a and closing member 4, is bridged material closed via a bellows 34. Apart from the passage openings 5c or 51c provided in locking elements 5 or 51 for the already mentioned passage flow V or V1 there are provided second passage openings 54 between the first connection elements 52, through which the above mentioned passage flows V and V1 can penetrate from the locking element unit 500 into the valve casing part 200 surrounding it, or vice versa. The illustrated embodiment realizes switching operations of the valve completely leakage-free. For this purpose there are



necessary two independent drive motions of rods 4a and/or 5a, which are activated by not shown means.

Figs. 10 to 12 show a further embodiment of the valve according to the invention. In the following reference is only made to the differences over the preceding figures, in particular over Figs. 4 to 6. Like in the embodiment according to Figs. 4 to 6 the locking elements 5 and 51 are in fixed connection against closing member 401, which is combined in one single structural element and now supports from outside the locking element 5 via connection bridge 4c and locking element 51 via connection bridge 400c. The distance between locking element 5 or 51 and closing member 401 is again s_1 . Apart from this, the remaining structure of the valve and its mode of operation are completely identical with that according to Figs. 4 to 6. A further description and explanation therefore is not necessary.

As far as its fundamental structure is concerned the embodiment according to Figs. 13 to 15 is explained by a direct comparison with the embodiment according to Figs. 10 to 12 and regarding the function and mode of operation of its locking elements 5 and 51 by a comparison with the embodiment according to Figs. 7 to 9. The single closing member 401 is now driven by at least one bar 4a disposed eccentrically. The locking elements 5 and 51 are connected to each other via a bar 5a which is activated by not shown means. Each of locking elements 5 and 51 is connected with said bar via a bridge 5b or 51b. Locking elements 5 and 51, bar 5a and bridges 5b and 51b together form a locking element unit 501, which is displaced with relative mobility against closing member 401.

The displacement distance from one open position of the valve to the other amounts to a total of the two-fold distance s_2 , which in the open position has an aperture cross section approximately corresponding to the nominal cross section of



the valve. Each of an upper and a lower penetration place, which are not designated in detail, between bar 5a and closing member 401 are bridged material closed by means of a bellows 26 or 261. In the normal position of the valve (Fig. 13) said bellows 26, 261 are mounted without tension, while in the open positions of the valve they are alternately stretched (26 in Fig. 14 and 261 in Fig. 15) or jolted (261 in Fig. 14 and 26 in Fig. 15).

The valve as shown in Figs. 1 to 15 can be realized by means of the features for seals, leakage cavities, locking elements and closing members as well as pertinent controlling parts as known from the above-mentioned patent applications P 37 01 027.1 and WO 88/05512.

Figs. 16 and 17 show an embodiment of the valve wherein closing member 4, 400 (Fig. 16) and closing member 401 (Fig. 17) are modified in their axial extension by means of assemblies 404, 408 or 405, 409 working telescope-like. 404 designates a telescopic bar and 408 a first guide bore. In Fig. 17 said structural elements are designated by 405 and 409. The distance between closing members 4 and 400 (Fig. 16) or between the first and the second closing member 402 and 403, respectively, is bridged material closed by means of a flexible connection element 406 or 407.

By means of these two embodiments it is possible to design the respective valve in its normal position ambivalent regarding the switching state of the two outer valve casing parts with respect to the middle valve casing part. In the case of a short distance between closing members 4, 400 and 402, 403 the valve is closed in its normal position, in the case of the largest distance possible, it is open in its normal position.



The claims defining the invention are as follows:

1. A valve for controlling the flow of fluid while permitting the isolated inlet of a medium to at least one leakage cavity, comprising:

5 a casing including a first end casing part, a middle casing part, and a second end casing part arranged in series, said casing defining an inner space;

first sealing means for providing a seal between said first end casing part and said middle casing part, and second sealing means for providing a seal between said middle casing part and said second end casing part, at least one of said first and second sealing means comprising two seals disposed in series;

10 at least one leakage cavity in the inner space of said casing, said cavity being connected with the environment of the valve between the two seals of one of said first and second sealing means;

15 closing means engageable with said first sealing means for placing said middle casing part out of communication with said first end casing part and simultaneously engageable with said second sealing means for placing said middle casing part out of communication with said second end casing part, said closing means comprising at least one closing member; and

20 shutter means selectively engageable with either one of said first and second sealing means for providing fluid communication between a selective adjacent pair of said casing parts, said shutter means comprising at least one shutter member having a through passage, said shutter member selectively engaging one of said first and second sealing means to thereby provide said fluid communication between one of said pairs of adjacent casing parts, and said closing means selectively engaging the other of said first and second sealing means to block fluid communication between the other of said pair of adjacent casing parts, said closing means and said shutter means
25 comprising means for selectively isolating said leakage cavity from the remainder of the inner space of said casing.

2. The valve of claim 1, wherein said first sealing means and said second sealing means comprises two seals disposed in series, and the valve further comprises two leakage cavities, one leakage cavity being connected with the environment of the valve

30



between the two seals of one of said first and second sealing means.

3. The valve of claim 1 or 2, wherein said closing means comprises two closing members, a first closing member movable between a first position in engagement with said first sealing means for placing said middle casing part out of communication with said first end casing part and a second position out of engagement with said first sealing means for placing said middle casing part in communication with said first end casing part, and a second closing member movable between a first position in engagement with said second sealing means for placing said middle casing part out of communication with said second end casing part and a second position out of engagement with said second sealing means for placing said middle casing part in communication with said second end casing part.

4. The valve of any one of the preceding claims wherein said shutter means is in engagement with said first sealing means when said first closing member is out of engagement with said first sealing means, and said shutter mean is in engagement with said second sealing means when said second closing member is out of engagement with and second sealing means.

5. The valve of any one of the preceding claims, wherein said shutter means comprises two shutter elements each having a through passage, including a first shutter element movable between a first position out of engagement with said first sealing means and a second position in engagement with said first sealing means, and a second shutter element movable between a first position out of engagement with said second sealing means and a second position in engagement with said second sealing means.

6. The valve of any one of the preceding claims wherein said shutter means is fixed relative to said closing means.

7. The valve of according to any one of claims 1 to 5 wherein said shutter means is mounted for movement relative to said closing means.



8. The valve of any one of the preceding claims wherein the valve has a first position in which said closing means is out of engagement with said first sealing means and said second sealing means, and said shutter means is in engagement with said first sealing means and said second sealing means, and a second position in which
5 said closing means is in engagement with one of said first sealing means and said second sealing means and out of engagement with the other of said first sealing and second sealing means, and said shutter means is in engagement with said other of said first sealing means and said second sealing means.

9. The valve of claim 8, wherein the valve has a third position in which said
10 closing means is in engagement with said first sealing means and said second sealing means, and said shutter means is out of engagement with said first sealing means and said second sealing means.

10. The valve of any one of the preceding claims wherein the through passage of
15 said shutter element extends from one of said end casing parts to said middle casing part when said shutter means is in engagement with said first sealing means and said second sealing means.

11. The valve of any one of the preceding claims wherein said closing means
comprises two closing members and a bar rigidly connecting said closing members.

12. The valve of any one of the preceding claims wherein said shutter means
20 comprises two shutter elements, each said shutter element being mounted at a fixed distance from said closing means and defining with said closing means a flow passage having a first area, and said casing defines flow passages, each having a second area, between said first end casing part and said middle casing part and between said
25 middle casing part and said second end casing part, said first area being substantially equal to said second area.

13. The valve of claim 1 wherein said shutter means comprises two shutter
elements connected to one another to define a shutter element unit, and said closing



means comprises two closing members, said shutter element unit being movably mounted between and relative to said closing members.

14. The valve of claim 13, further comprising means for mounting the shutter element unit for movement to a predetermined distance from each closing member to
5 define with each closing member a flow passage having a first area, and said casing defines flow passages each having a second area between said first end casing part and said middle casing part and between said middle casing part and said second end casing part, said first area being substantially equal to said second area.

15. The valve of claim 13 or 14 wherein said closing means comprises two closing
10 members, means extending between said closing members for connecting said closing members for movement relative to one another, and means extending between said closing members and surrounding said connecting means for separating said connecting means from the inner space of the casing, said connecting means comprising a flexible connection element.

16. A method for controlling a valve comprising a casing including a first end casing part, a middle casing part, and a second end casing part arranged in series, said casing defining an inner space;

first sealing means for providing a seal between said first end casing part and said middle casing part, and second sealing means for providing a seal between said
20 middle casing part and said second end casing part, at least one of said first and second sealing means comprising two seals disposed in series;

at least one leakage cavity in the inner space of said casing, said cavity being connected with the environment of the valve between the two seals of one of said first and second sealing means;

25 closing means engageable with said first sealing means for placing said middle casing part out of communication with said first end casing part and simultaneously engageable with said second sealing means for placing said middle casing part out of communication with said second end casing part, said closing means comprising at least one closing member; and



shutter means selectively engageable with either one of said first and second sealing means for providing fluid communication between a selective adjacent pair of said casing parts, said shutter means comprising at least one shutter member having a through passage, said shutter member selectively engaging one of said first and second sealing means to thereby provide said fluid communication between one of said pairs of adjacent casing parts, and said closing means selectively engaging the other of said first and second sealing means to block fluid communication between the other of said pair of adjacent casing parts, said closing means and said shutter means comprising means for selectively isolating said leakage cavity from the remainder of the inner space of said casing;

said method comprising;

moving said closing member between a first position in engagement with said first sealing means and a second position out of engagement with sealing means; and

moving said shutter element into engagement with said first sealing means when said closing member is in said second position.

17. A valve substantially as hereinbefore described with reference to the accompanying drawings.

18. Apparatus for controlling the medium inlet into at least one leakage cavity of a valve substantially as hereinbefore described with reference to any one of the particular embodiments shown in the accompanying drawings.

19. A method for controlling a valve substantially as described with reference to any one of the particular embodiments shown in the accompanying drawings.

DATED this 30th day of January, 1992

HANS-OTTO MIETH

25

CARTER SMITH & BEADLE

Qantas House, 2 Railway Parade,

Camberwell, Victoria 3124,

Australia.



Summary

The invention relates to a process for controlling the medium inlet into at least one leakage cavity of a valve according to the opening part of claim 1.

When applying the proposed process to a polyway-switching valve, the construction of which is novel per se, a valve is created which is novel with view to the switching function and with view to its properties, in particular the leak-proof property of each individual seat region.

In the procedural technique this is inter alia achieved in that in the valve position deviating from the normal position there is provided at each switched valve seat a substitution of the closing member or locking element by the respective other one for shutting off the leakage cavity from the inner space. (Fig. 7)



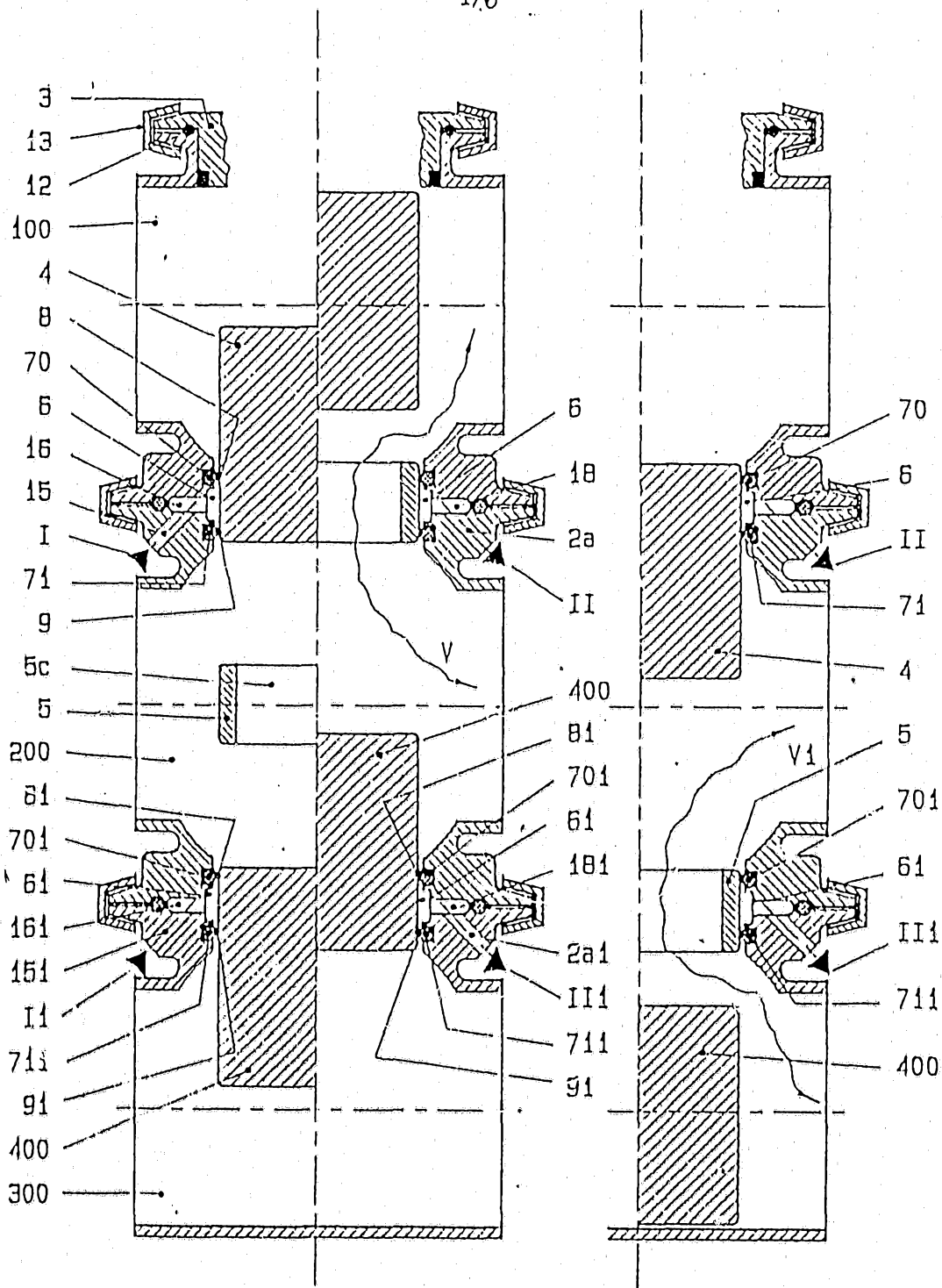
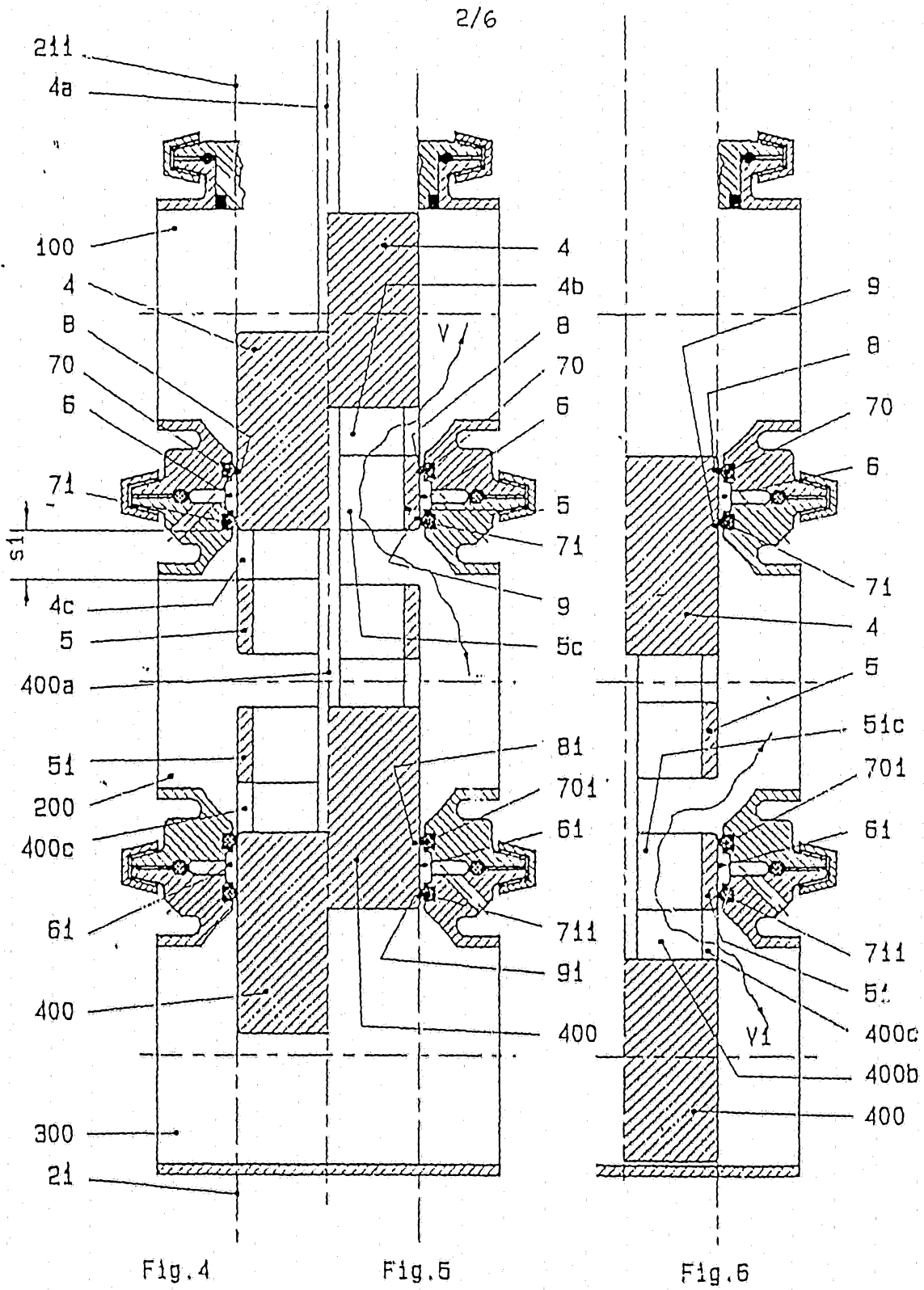
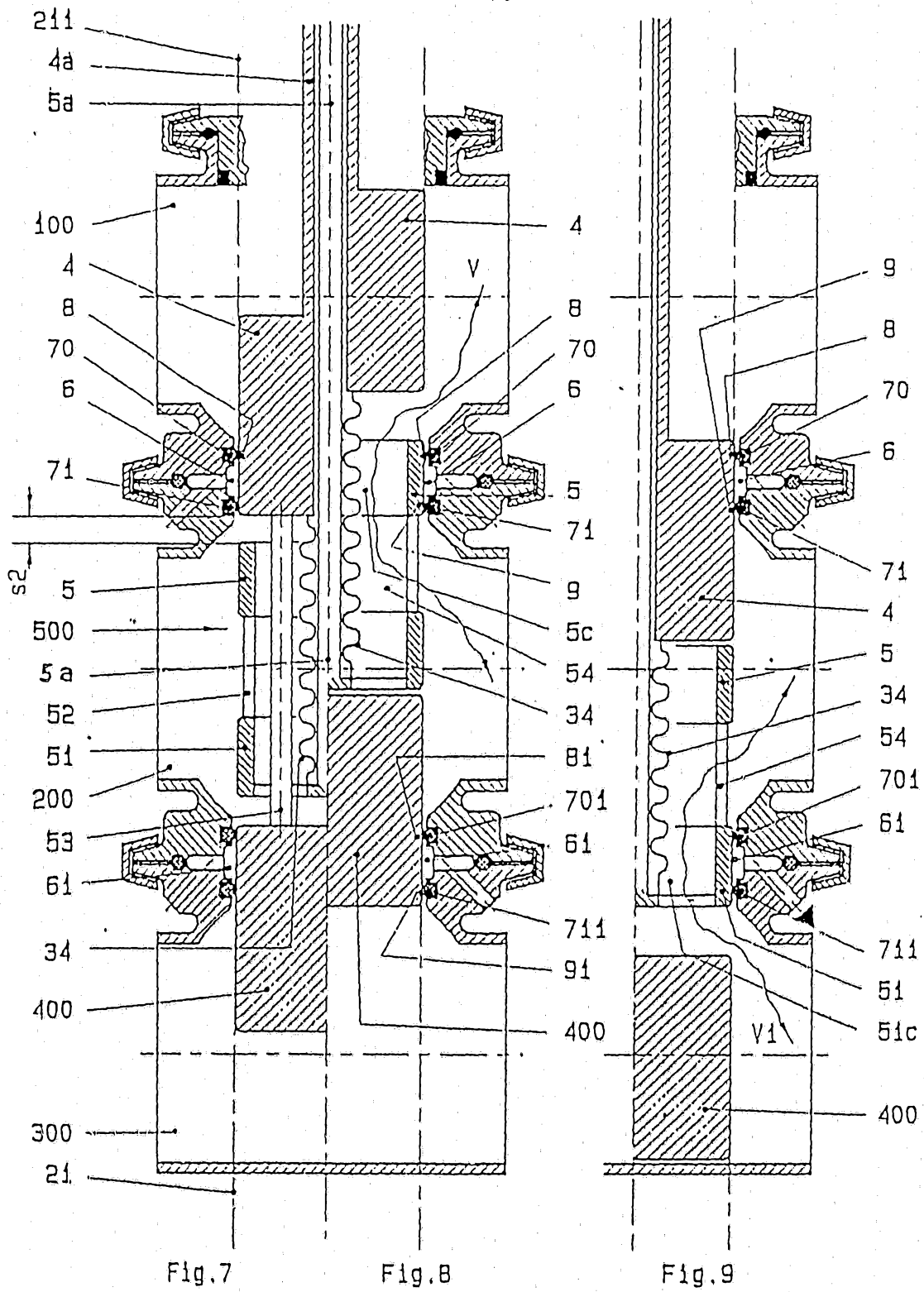

Fig. 1

Fig. 2

Fig. 3





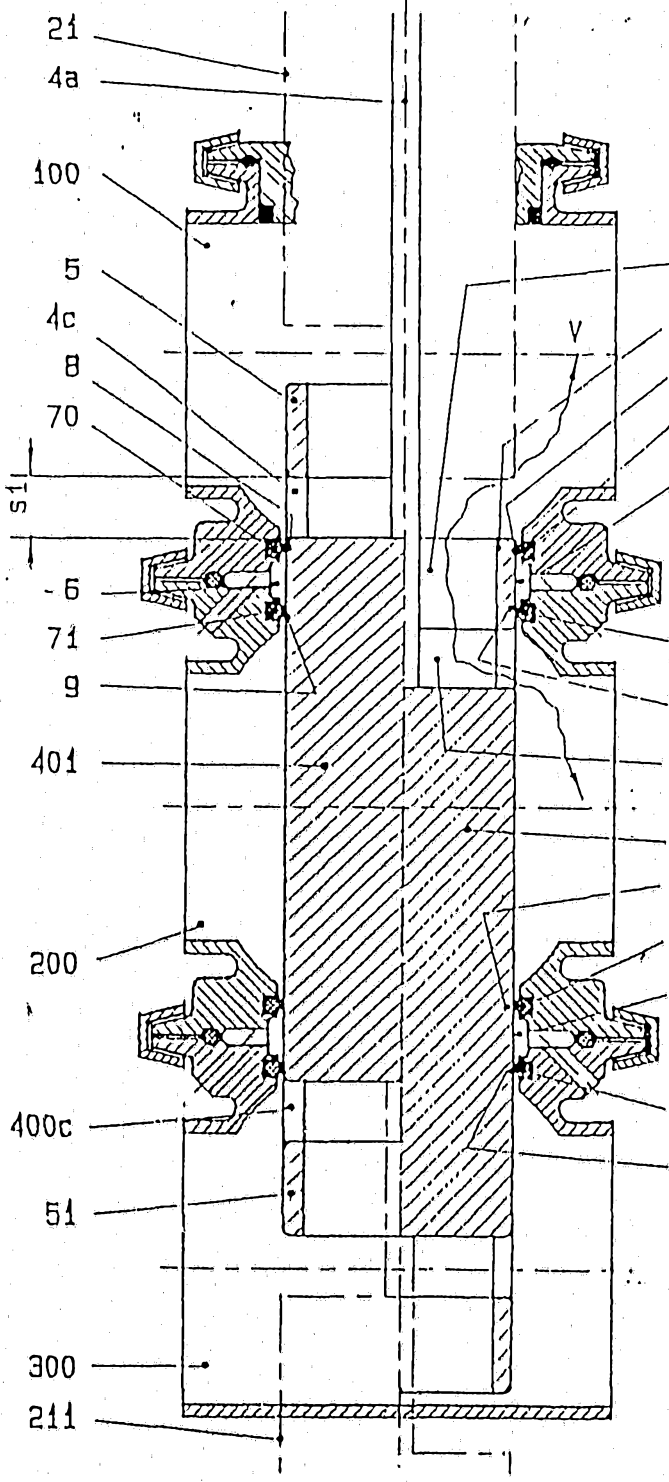

Fig. 10

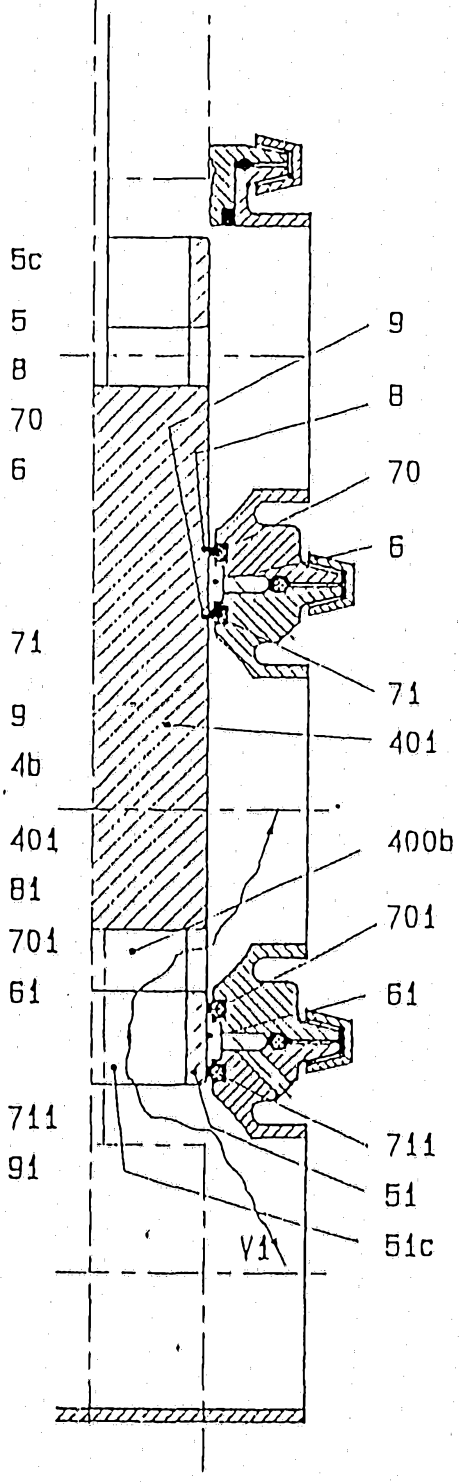

Fig. 11

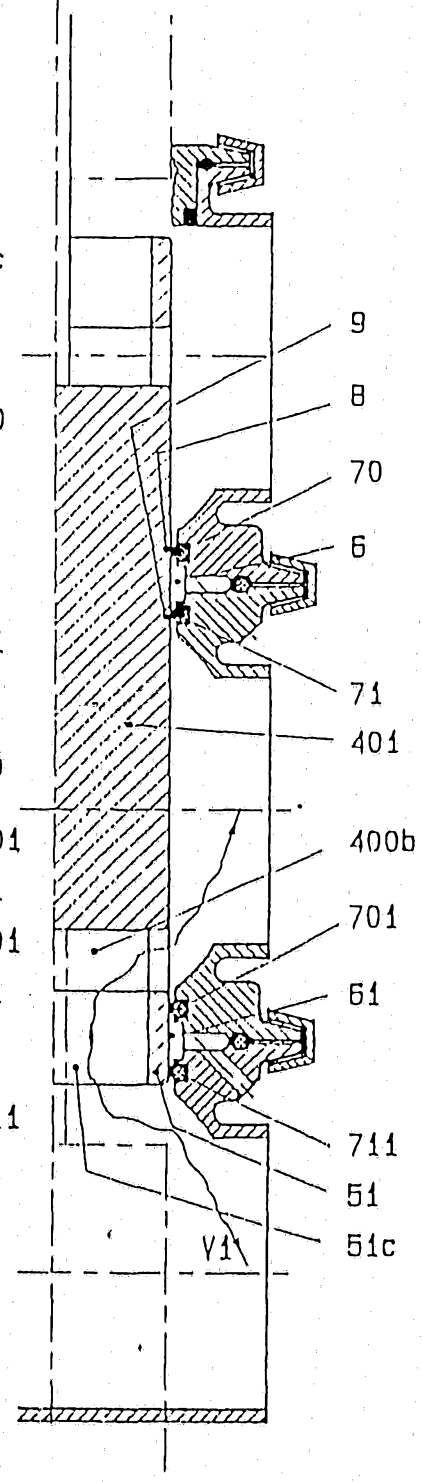

Fig. 12

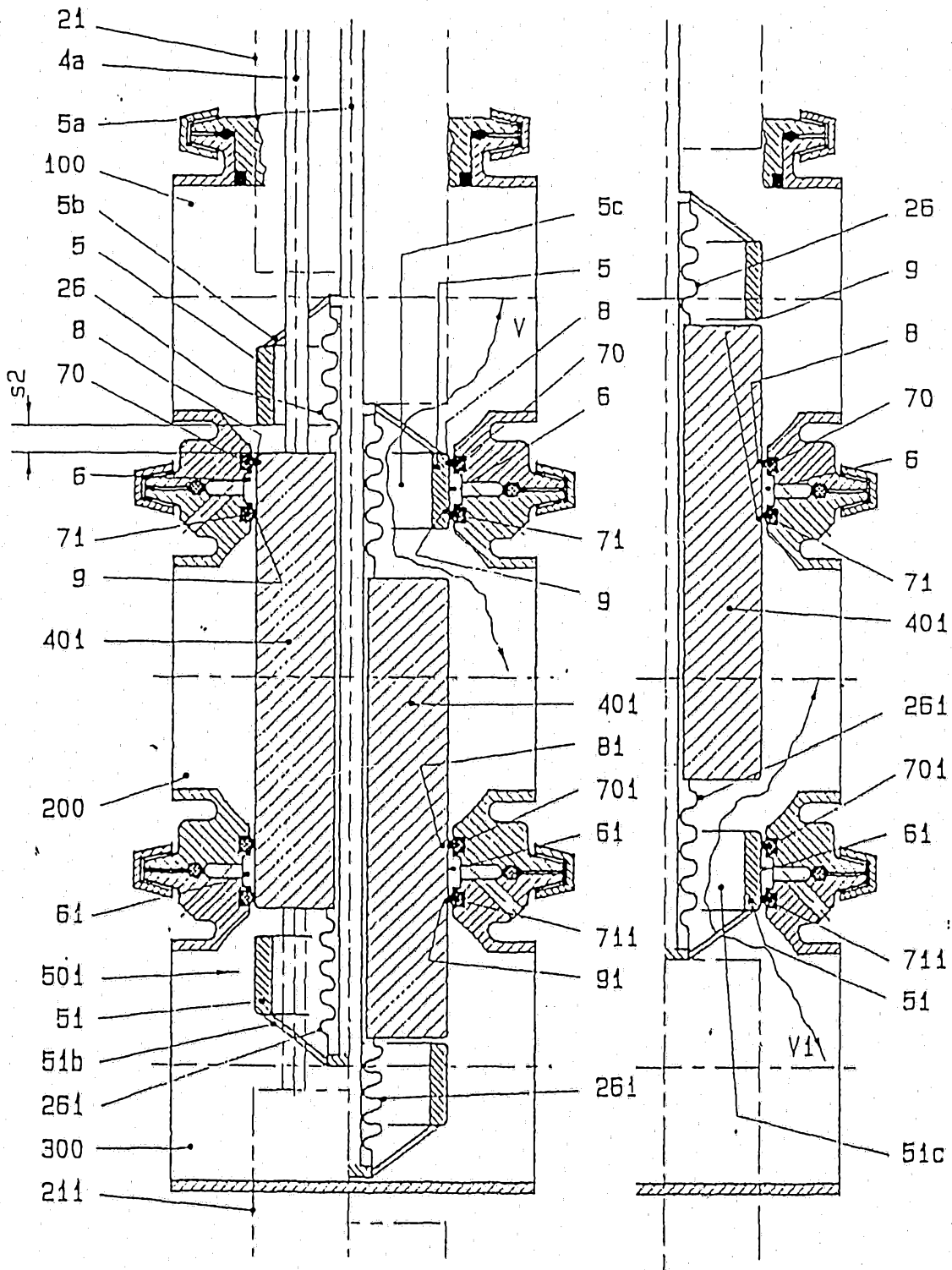

Fig. 13

Fig. 14

Fig. 15

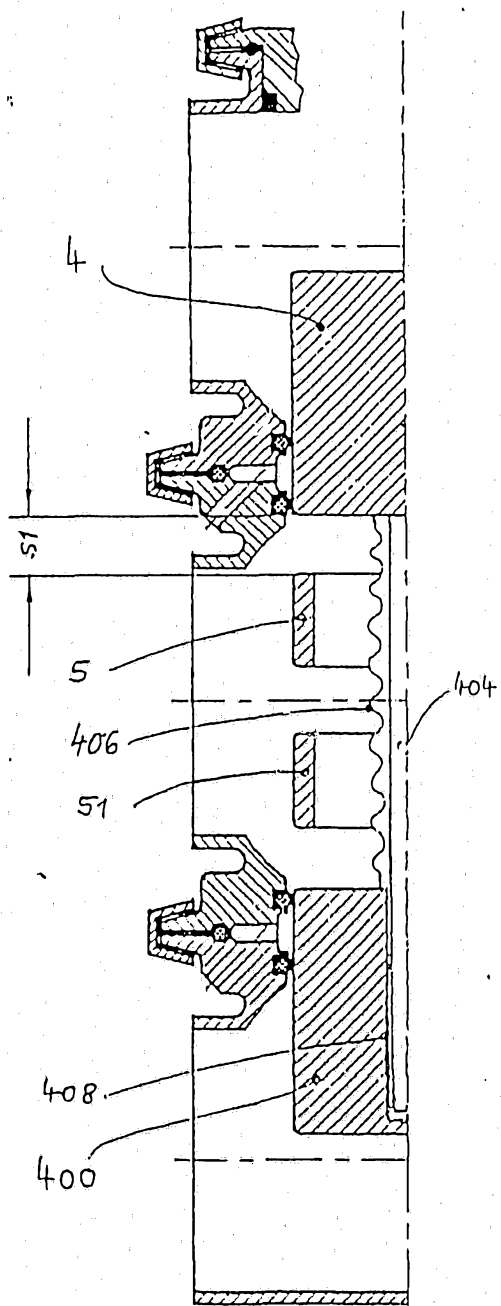

Fig. 16

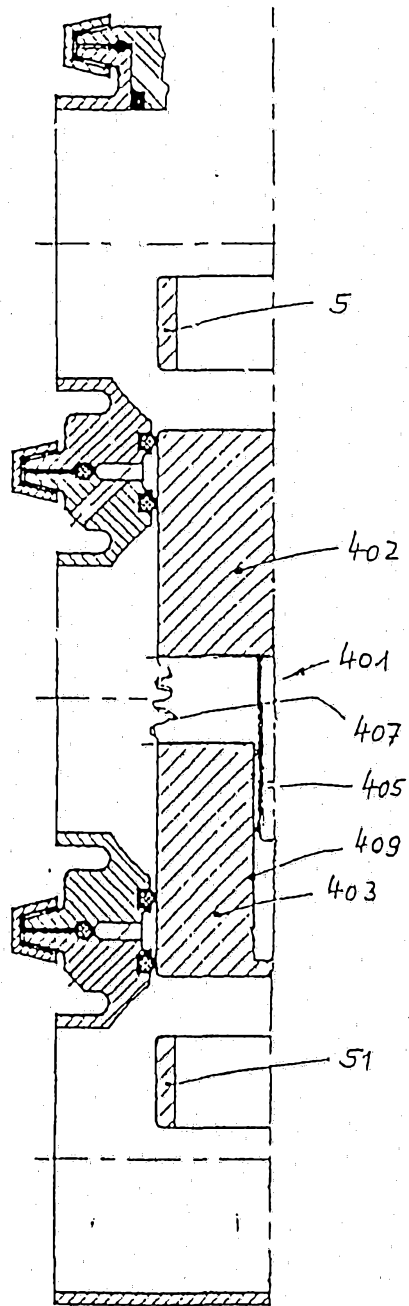

Fig. 17

INTERNATIONAL SEARCH REPORT

International Application No PCT/EP89/00045

I. CLASSIFICATION OF SUBJECT MATTER (If several classification symbols apply, indicate all) ⁶				
According to International Patent Classification (IPC) or to both National Classification and IPC Int.Cl. F 16 K 11/07, F 16 K 37/00, F 16 K 25/02				
II. FIELDS SEARCHED				
Minimum Documentation Searched ⁷				
Classification System	Classification Symbols			
Int.Cl. ⁴	F 16 K 11/00, F 16 K 3/00, F 16 K 25/00, F 16 K 37/00			
Documentation Searched other than Minimum Documentation to the Extent that such Documents are Included in the Fields Searched ⁸				
III. DOCUMENTS CONSIDERED TO BE RELEVANT ⁹				
Category ⁹	Citation of Document, ¹¹ with indication, where appropriate, of the relevant passages ¹²	Relevant to Claim No. ¹³		
P, Y	DE, A, 3701027 (H.O. MIETH) 28 July 1988, see the abstract cited in the application -----	1		
Y	US, A, 3283783 (CLARY CORP.) 8 November 1966, see column 2, lines 30-56 -----	1		
P, Y	EP, A, 0257539 (ECKER MASCHINENBAU GmbH) 2 March 1988, see column 5, line 21 - column 6, line 10 -----	1		
A	FR, A, 2222590 (NOBRO PNEUMATICS LTD) 18 October 1974, see claims 1,2 -----	1		
A	US, A, 4664151 (FUTURECRAFT CORP.) 12 May 1987 -----			
A	US, A, 4374583 (HALLIBURTON CO.) 22 February 1983 -----			
A	US, A, 3643700 (D.L. BLACK) 22 February 1972 -----			
<table style="width: 100%; border: none;"> <tr> <td style="width: 50%; vertical-align: top;"> <ul style="list-style-type: none"> * Special categories of cited documents: ¹⁰ "A" document defining the general state of the art which is not considered to be of particular relevance "E" earlier document but published on or after the international filing date "L" document which may throw doubts on priority claim(s) or which is cited to establish the publication date of another citation or other special reason (as specified) "O" document referring to an oral disclosure, use, exhibition or other means "P" document published prior to the international filing date but later than the priority date claimed </td> <td style="width: 50%; vertical-align: top;"> <ul style="list-style-type: none"> "T" later document published after the international filing date or priority date and not in conflict with the application but cited to understand the principle or theory underlying the invention "X" document of particular relevance; the claimed invention cannot be considered novel or cannot be considered to involve an inventive step "Y" document of particular relevance; the claimed invention cannot be considered to involve an inventive step when the document is combined with one or more other such documents, such combination being obvious to a person skilled in the art. "Δ" document member of the same patent family </td> </tr> </table>			<ul style="list-style-type: none"> * Special categories of cited documents: ¹⁰ "A" document defining the general state of the art which is not considered to be of particular relevance "E" earlier document but published on or after the international filing date "L" document which may throw doubts on priority claim(s) or which is cited to establish the publication date of another citation or other special reason (as specified) "O" document referring to an oral disclosure, use, exhibition or other means "P" document published prior to the international filing date but later than the priority date claimed 	<ul style="list-style-type: none"> "T" later document published after the international filing date or priority date and not in conflict with the application but cited to understand the principle or theory underlying the invention "X" document of particular relevance; the claimed invention cannot be considered novel or cannot be considered to involve an inventive step "Y" document of particular relevance; the claimed invention cannot be considered to involve an inventive step when the document is combined with one or more other such documents, such combination being obvious to a person skilled in the art. "Δ" document member of the same patent family
<ul style="list-style-type: none"> * Special categories of cited documents: ¹⁰ "A" document defining the general state of the art which is not considered to be of particular relevance "E" earlier document but published on or after the international filing date "L" document which may throw doubts on priority claim(s) or which is cited to establish the publication date of another citation or other special reason (as specified) "O" document referring to an oral disclosure, use, exhibition or other means "P" document published prior to the international filing date but later than the priority date claimed 	<ul style="list-style-type: none"> "T" later document published after the international filing date or priority date and not in conflict with the application but cited to understand the principle or theory underlying the invention "X" document of particular relevance; the claimed invention cannot be considered novel or cannot be considered to involve an inventive step "Y" document of particular relevance; the claimed invention cannot be considered to involve an inventive step when the document is combined with one or more other such documents, such combination being obvious to a person skilled in the art. "Δ" document member of the same patent family 			
IV. CERTIFICATION				
Date of the Actual Completion of the International Search	Date of Mailing of this International Search Report			
20 June 1989 (20.06.89)	12 July 1989 (12.07.89)			
International Searching Authority European Patent Office	Signature of Authorized Officer			

III. DOCUMENTS CONSIDERED TO BE RELEVANT (CONTINUED FROM THE SECOND SHEET)

-2-

Category *	Citation of Document, with indication, where appropriate, of the relevant passages	Relevant to Claim No
A	US, A, 2659568 (GROVE REGULATOR CO.) 17 November 1953 -----	
A	BE, A, 447878 (V. MARZOCCHI & CIE) 31 December 1942 -----	

ANNEX TO THE INTERNATIONAL SEARCH REPORT
ON INTERNATIONAL PATENT APPLICATION NO.

EP 8900045
SA 26380

This annex lists the patent family members relating to the patent documents cited in the above-mentioned international search report. The members are as contained in the European Patent Office EDP file on 29/06/89. The European Patent Office is in no way liable for these particulars which are merely given for the purpose of information.

Patent document cited in search report	Publication date	Patent family member(s)	Publication date
DE-A- 3701027	28-07-88	AU-A- 1151888	10-08-88
		WO-A- 8805512	28-07-88
		EP-A- 0279177	24-08-88
		EP-A- 0299029	18-01-89
		ZA-A- 8800260	29-06-88
US-A- 3283783		None	
EP-A- 0257539	02-03-88	DE-A- 3722053	03-03-88
FR-A- 2222590	18-10-74	GB-A- 1459764	31-12-76
		AU-A- 6646974	11-09-75
		BE-A- 811769	01-07-74
		CH-A- 571669	15-01-76
		DE-A- 2412652	03-10-74
		JP-A- 50026122	19-03-75
		NL-A- 7403299	24-09-74
US-A- 4664151	12-05-87	US-A- 4719681	19-01-88
US-A- 4374583	22-02-83	None	
US-A- 3643700	22-02-72	None	
US-A- 2659568		None	
BE-A- 447878		None	

INTERNATIONALER RECHERCHENBERICHT

Internationales Aktenzeichen PCT/EP 89/00045

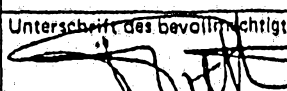
I. KLASSIFIKATION DES ANMELDUNGSGEGENSTANDS (bei mehreren Klassifikationssymbolen sind alle anzugeben) ⁶		
Nach der Internationalen Patentklassifikation (IPC) oder nach der nationalen Klassifikation und der IPC		
Int. Cl. 4 F 16 K 11/07, F 16 K 37/00, F 16 K 25/02		
II. RECHERCHIERTE SACHGEBIETE		
Recherchierter Mindestprüfstoff ⁷		
Klassifikationssystem	Klassifikationssymbole	
Int. Cl. 4	F 16 K 11/00, F 16 K 3/00, F 16 K 25/00, F 16 K 37/00	
Recherchierte nicht zum Mindestprüfstoff gehörende Veröffentlichungen, soweit diese unter die recherchierten Sachgebiete fallen ⁸		
III. EINSCHLÄGIGE VERÖFFENTLICHUNGEN⁹		
Art*	Kennzeichnung der Veröffentlichung ¹¹ , soweit erforderlich unter Angabe der maßgeblichen Teile ¹²	Betr. Anspruch Nr. ¹³
P, Y	DE, A, 3701027 (H.O. MIETH) 28. Juli 1988, siehe Zusammenfassung in der Anmeldung erwähnt --	1
Y	US, A, 3283783 (CLARY CORP.) 8. November 1966, siehe Spalte 2, Zeilen 30-56 --	1
P, Y	EP, A, 0257539 (ECKER MASCHINENBAU GmbH) 2. März 1988, siehe Spalte 5, Zeile 21 - Spalte 6, Zeile 10 --	1
A	FR, A, 2222590 (NOBRO PNEUMATICS LTD) 18. Oktober 1974, siehe Ansprüche 1,2 --	1
A	US, A, 4664151 (FUTURECRAFT CORP.) 12. Mai 1987 --	./.
<p>* Besondere Kategorien von angegebenen Veröffentlichungen¹⁰:</p> <p>"A" Veröffentlichung, die den allgemeinen Stand der Technik definiert, aber nicht als besonders bedeutsam anzusehen ist</p> <p>"E" älteres Dokument, das jedoch erst am oder nach dem internationalen Anmeldedatum veröffentlicht worden ist</p> <p>"L" Veröffentlichung, die geeignet ist, einen Prioritätsanspruch zweifelhaft erscheinen zu lassen, oder durch die das Veröffentlichungsdatum einer anderen im Recherchenbericht genannten Veröffentlichung belegt werden soll oder die aus einem anderen besonderen Grund angegeben ist (wie ausgeführt)</p> <p>"O" Veröffentlichung, die sich auf eine mündliche Offenbarung, eine Benützung, eine Ausstellung oder andere Maßnahmen bezieht</p> <p>"P" Veröffentlichung, die vor dem internationalen Anmeldedatum, aber nach dem beanspruchten Prioritätsdatum veröffentlicht worden ist</p> <p>"T" Spätere Veröffentlichung, die nach dem internationalen Anmeldedatum oder dem Prioritätsdatum veröffentlicht worden ist und mit der Anmeldung nicht kollidiert, sondern nur zum Verständnis des der Erfindung zugrundeliegenden Prinzips oder der ihr zugrundeliegenden Theorie angegeben ist</p> <p>"X" Veröffentlichung von besonderer Bedeutung; die beanspruchte Erfindung kann nicht als neu oder auf erfinderischer Tätigkeit beruhend betrachtet werden</p> <p>"Y" Veröffentlichung von besonderer Bedeutung; die beanspruchte Erfindung kann nicht als auf erfinderischer Tätigkeit beruhend betrachtet werden, wenn die Veröffentlichung mit einer oder mehreren anderen Veröffentlichungen dieser Kategorie in Verbindung gebracht wird und diese Verbindung für einen Fachmann naheliegend ist</p> <p>"&" Veröffentlichung, die Mitglied derselben Patentfamilie ist</p>		
IV. BESCHEINIGUNG		
Datum des Abschlusses der internationalen Recherche	Absenddatum des internationalen Recherchenberichts	
20. Juni 1989	12 JUL 1989	
Internationale Recherchenbehörde	Unterschrift des bevollmächtigten Bediensteten	
Europäisches Patentamt	 P.C.G. VAN DER PUTTEN	

III. EINSCHLÄGIGE VERÖFFENTLICHUNGEN (Fortsetzung von Blatt 2)		
Art *	Kennzeichnung der Veröffentlichung, soweit erforderlich unter Angabe der maßgeblichen Teile	Betr. Anspruch Nr.
A	US, A, 4374583 (HALLIBURTON CO.) 22. Februar 1983 --	
A	US, A, 3643700 (D.L. BLACK) 22. Februar 1972 --	
A	US, A, 2659568 (GROVE REGULATOR CO.) 17. November 1953 --	
A	BE, A, 447878 (V. MARZOCCHI & CIE) 31. Dezember 1942 ----	