

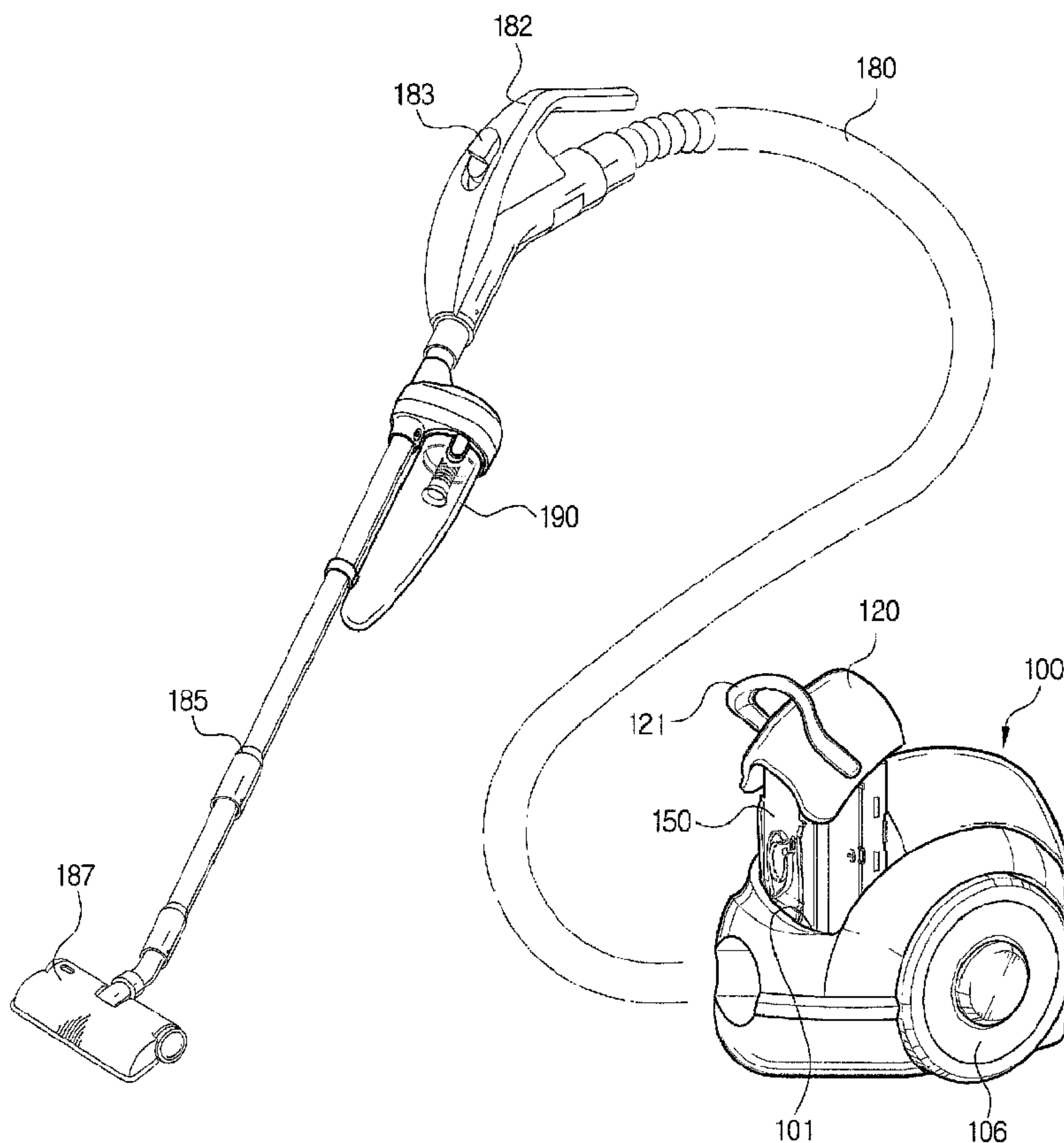

(22) Date de dépôt/Filing Date: 2003/11/18  
 (41) Mise à la disp. pub./Open to Public Insp.: 2004/10/04  
 (45) Date de délivrance/Issue Date: 2007/05/01  
 (30) Priorité/Priority: 2003/04/04 (KR2003-21456)

(51) Cl.Int./Int.Cl. *A47L 9/16* (2006.01),  
*A47L 9/00* (2006.01), *A47L 9/10* (2006.01),  
*A47L 9/12* (2006.01)  
 (72) Inventeurs/Inventors:  
 LEE, HYUN-JU, KR;  
 YOO, DONG-HUN, KR  
 (73) Propriétaire/Owner:  
 SAMSUNG GWANGJU ELECTRONICS CO., LTD., KR  
 (74) Agent: FETHERSTONHAUGH & CO.

(54) Titre : ASPIRATEUR SANS SAC  
 (54) Title: BAGLESS VACUUM CLEANER



(57) **Abrégé/Abstract:**

A vacuum cleaner including a brush, a driving motor for generating a suction force, a main body including said driving motor and a filter mounting, a dust suction tube having one end connected to said filter mounting and the other end connected to said brush, a filter assembly mounted within said filter mounting to filter out dust from external air drawn into the main body through said dust suction tube and the brush, and a main body cover coupled to the filter assembly to facilitate the selective insertion and removal of the filter assembly into and from said filter mounting and locked to said main body.

## ABSTRACT OF THE DISCLOSURE

A vacuum cleaner including a brush, a driving motor for generating a suction force, a main body including said driving motor and a filter mounting, a dust suction tube having one end connected to said filter mounting and the other end connected to said brush, a filter assembly  
5 mounted within said filter mounting to filter out dust from external air drawn into the main body through said dust suction tube and the brush, and a main body cover coupled to the filter assembly to facilitate the selective insertion and removal of the filter assembly into and from said filter mounting and locked to said main body.

## BAGLESS VACUUM CLEANER

### BACKGROUND OF THE INVENTION

#### 1. Field of the Invention

5           The present invention relates generally to a vacuum cleaner, and more particularly to a bagless vacuum cleaner which can completely filter out dust, dirt and debris, and which enables a user to easily remove collected dust and to clean a filter, without the need to replace the dust filter.

#### 2. Description of the Related Art

10           As shown in FIG. 1, a conventional vacuum cleaner comprises a main body 201, a flexible hose 210, an extended tube 212, an operation handle 221 provided with a switch 220, and a brush 230.

          The main body 201 includes a motor (not shown) for generating a suction force, a filter mounting 204, a replaceable paper bag 205, a main body cover 203 and wheels 202. Generally, the motor (not shown) is mounted in the rear part of the main body 201. The main body cover 203 has an air suction hole 206 for suction of air into the main body. Also, the filter mounting 204 is provided in the front part of the main body 201 and receives the paper bag 205. It is typical to provide at least one pair of wheels 202 for easily moving the main body 201 of the vacuum cleaner.

One end of the flexible hose 210 is connected to the air suction hole 206, while the other end is connected to the operation handle 221. The operation handle 221 is provided with the switch 220 for selectively operating or stopping operation of the vacuum cleaner. The extended tube 212 has one end connected to the operation handle 221 and the other connected to the brush 230. The brush 230 tightly contacts a dirty floor to be cleaned and drawn in air containing any bits of dust, dirt and debris by the suction force generated by the vacuum cleaner.

The air is drawn into the main body 201 through the extended tube 212 and the flexible hose 210. When passing through the paper bag 205, the air, including the entrained dust, dirt and debris, is filtered so that only clean air with dust removed is vented out from the main body 201 through the motor.

Since a conventional vacuum cleaner uses a consumable paper bag 205, the user has to regularly replace the paper bag 205 with a new one. Also, the paper bag 205, which filters out dust in a primary filtering stage, cannot sufficiently or completely filter out an excessive amount of dust, dirt and debris.

In addition, when replacing the paper bag 205 with a new one in the conventional vacuum cleaner, it is necessary for the user to open the main body cover 203 and hold it with one hand, while removing the paper bag 205 and inserting a new paper bag with the other hand. Even if the main body cover 203 is detachable from the main body, the user must first separate the main body cover 203 in order to remove the paper bag 205.

Also, it is not easy to see whether the air suction hole 206 of the main body cover 203 exactly fits with an inlet 207 of the paper bag 205. If the user does not properly insert the paper bag 205 into the filter mounting 204 and the paper bag inlet 207 does not correspond with the air suction hole 206, dust particles will accumulate within the filter mounting 204, without being sufficiently filtered out. This may eventually cause mechanical trouble with the vacuum cleaner.

#### SUMMARY OF THE INVENTION

Accordingly, the present invention has been made to solve the above-mentioned problems occurring in conventional vacuum cleaners, and one object of the present invention is to provide a bagless vacuum cleaner which eliminates the need to replace a filter.

Another object of the present invention is to provide a bagless vacuum cleaner, which can sufficiently remove dust, dirt and debris by filtering the air containing dust in successive filtering operations.

Still another object of the present invention is to provide a bagless vacuum cleaner having an easily detachable filter assembly, which can prevent operation of the vacuum cleaner when the filter assembly is incompletely assembled.

In order to accomplish the above objects, there is provided a vacuum cleaner comprising: a brush; a driving motor for generating a suction force; a main body including said driving motor and a filter mounting; a dust suction tube having one end connected to said filter mounting and the other

end connected to said brush; a filter assembly mounted within said filter mounting to filter out dust from external air drawn into the main body through said dust suction tube and said brush; and a main body cover coupled with the filter assembly to facilitate the insertion and removal of the filter assembly into and from said filter mounting and being capable of locking to said main body.

5            Preferably, the filter assembly comprises: a filter housing having an opening; a first filter unit locked into the filter housing; and a second filter unit placed between and endwall of the filter housing and the first filter unit. Also, it is desirable that the filter housing includes an engagement loop connected to the main body cover and a safety lever for preventing the filter assembly from being mounted into the filter mounting when the first filter unit is not completely  
10 locked into the filter housing.

The filter housing further comprises an opening cover for selectively opening and closing said opening. Preferably, the second filter unit should include a second filter; a second filter holder for supporting the second filter; and a filter net enclosing the second filter within the second filter holder.

15            The first filter unit preferably includes a first filter and a first filter holder for supporting the first filter.

In order to accomplish the above objects of the present invention, there is also provided a bagless vacuum cleaner comprising: a brush; a driving motor for generating a suction force; a main body including said driving motor and a filter mounting; a dust suction tube having one end

connected to said filter mounting and the other end connected to said brush; a cyclone dust collector provided in said dust suction tube for separating the dust from air drawn in by circulating the air within the cyclone dust collector; a filter assembly mounted within said filter mounting and comprising a filter housing, a first filter unit and a second filter unit to filter out dust and dirt from  
5 external air drawn into the main body through the dust suction tube and the brush; and a main body cover having first, second and third hooks, each of which are shaped and configured to engage the filter assembly, and a handle for facilitating the selective insertion and removal of the filter assembly into and from said filter mounting.

Preferably, the handle of the main body cover has at least one hook which can be locked  
10 into corresponding locking grooves formed on the main body. Also, it is desirable to provide the filter assembly with a safety lever for preventing the filter assembly from being mounted into the filter mounting when incompletely assembled.

The filter housing of the filter assembly has an opening which exactly fits with the dust suction tube, an opening cover for selectively opening and closing said opening, an engagement  
15 loop shaped and configured to engage the first hook of the main body cover, and a plurality of locking jaws which can be engaged into the second and third hooks of the main body cover.

Also, the bagless vacuum cleaner according to the present invention may comprise: a brush; a driving motor for generating a suction force; a main body including said driving motor, a filter mounting having a filter guide; a dust suction tube having one end connected to said filter

mounting and the other end connected to said brush; a cyclone dust collector provided in said dust suction tube to remove dust from air drawn into the cyclone dust collector by circulating the air within the cyclone dust collector; a filter assembly mounted into said filter mounting and comprising a filter housing and a first filter unit locked into the filter housing; and a main body cover detachable from the filter assembly and the main body and provided with a handle.

The handle of the main body cover has a plurality of hooks which are shaped and configured to lock into locking grooves formed on the main body. Preferably, the filter assembly includes a support projection and at least one locker for holding a tool capable of cleaning the filter on one side thereof.

Accordingly, the bagless vacuum cleaner of the present invention produces the greatest filtering effect due to triple filtering by the filter assembly comprising the first and second filter units and the cyclone dust collector.

Since the filter assembly is semi-permanent, the user can reduce expenditures by not replacing filters.

Also, the safety lever provided on the filter housing prevents any incomplete insertion of the filter assembly into the filter mounting and ensures complete filtration.

Since the bagless vacuum cleaner of the present invention connects the main body cover to the filter assembly and provides a handle on the main body cover, the user can easily insert and separate the filter assembly, without the need to touch the filter assembly. In other words, the

user can insert and separate the filter assembly, without dirtying his or her hands.

Further, the opening formed on the filter housing is automatically opened and closed by the opening cover. Since the filter assembly is inserted or separated according to the guide of a guide member, the opening of the filter housing can exactly fit to correspond with the air suction  
 5 hole. When the filter assembly is separated, no dust or dirt from the filter assembly will be permitted to dirty the surroundings.

#### BRIEF DESCRIPTION OF THE DRAWINGS

The above objects and other advantages of the present invention will be more apparent  
 10 from the following detailed description taken in conjunction with the accompanying drawings, in which:

FIG.1 is a perspective view of a conventional vacuum cleaner;

FIG. 2 is a perspective view of a vacuum cleaner according to the present invention;

FIG. 3 is an exploded perspective view of a filter assembly of the bagless vacuum cleaner  
 15 according to the present invention;

FIG. 4 is a perspective detail view of the filter housing shown in FIG. 3, which shows the configuration of a safety lever of the filter housing;

FIG. 5 is a perspective view in partial cross-section, taken approximately along line V-V of FIG. 3, which shows the engagement of the filter housing with a first filter unit;

FIG. 6 is a plan view showing the filter assembly being inserted into a filter mounting of the main body of the bagless vacuum cleaner according to the present invention, without being completely assembled;

FIGS. 7 to 9 illustrate the process of inserting a filter assembly into a filter mounting of the vacuum cleaner according to the present invention, wherein

FIG. 7 is a perspective view of the filter assembly before being inserted into the filter mounting;

FIG. 8 is a partial perspective view showing the inside structure of the filter mounting; and

FIG. 9 is a perspective view of the filter assembly after insertion into the filter mounting;

FIGS. 10 to 12 illustrate the connection of the filter assembly and the main body cover and a process for providing the connection, wherein

FIG. 10 is a perspective view of the main body cover, including the filter housing of the filter assembly according to the present invention; and

FIGS. 11 and 12 are representative views showing the stages of the process of connecting the filter housing of the filter assembly with the main body cover and the process of separating the two elements; and

FIG. 13 is a perspective view of the main body with the main body cover closed, showing the connection of the handle provided on the main body cover to the main body.

## DETAILED DESCRIPTION OF THE PREFERRED EMBODIMENTS

Hereinafter, a preferred embodiment of the present invention will be described in detail with reference to the accompanying drawings.

FIG. 2 is a perspective view generally showing a bagless vacuum cleaner according to the present invention. As shown in FIG. 2, the bagless vacuum cleaner of the present invention comprises a main body 100, a filter assembly 150, a flexible hose 180, a cyclone dust collector 190, an extended tube 185, a brush 187 and a handle 182, including a switch 183. The flexible hose 180 and the extended tube 185 constitute a dust suction tube.

The main body 100 includes a main body cover 120, at least one wheel 106 and a driving motor (not shown). The main body 100 further includes a filter mounting 101. The main body cover 120 is provided with a cover handle 121 which is useful in inserting or removing the filter assembly 150, fixed to the main body cover 120 into or from the filter mounting 101. The filter assembly 150 is shaped and configured for insertion into the filter mounting 101. Since the extended tube 185, brush 187, handle 182 and flexible hose 180 are conventional elements and included in a conventional vacuum cleaner, as shown in FIG. 1, no further explanation will be made with respect to these elements.

FIG. 3 is an exploded perspective view showing the filter assembly of the bagless vacuum cleaner according to the present invention. FIG. 4 is a perspective detail view of the filter housing shown in FIG. 3, which shows the configuration of a safety lever of the filter housing.

FIG. 5 is a perspective view in partial cross-section taken approximately along line V-V of FIG. 3, which shows the connection of the filter housing to a first filter unit. FIG. 6 is a plan view showing the filter assembly being inserted into the filter mounting, without being completely assembled.

5 As shown in the above drawings, the filter assembly 150 (FIGS. 2 and 6) includes a filter housing 152 (FIGS. 3-5), a first filter unit 170 and a second filter unit 160. The filter housing 152 includes a safety lever 153 and an engagement loop 154, respectively disposed at a lower part and an upper part thereof. Also, the filter housing 152 has an opening 155 formed at a sidewall through which external air is drawn in, and a plurality of engagement recesses 152a formed in  
10 opposite sidewalls of the filter housing 152 contacting the first filter unit 170.

The first filter unit 170 includes a first filter 171 and a first filter holder 172. The first filter 171, being a pleated filter, is nested within and supported by the first filter holder 172. The first filter holder 172 includes a plurality of laterally extending engagement projections 172a which are shaped and configured to lock into the engagement recesses 152a of the filter housing 152.

15 The second filter unit 160 includes a second filter 161 and a second filter holder 162. The second filter 161 is generally made of a porous material, such as a sponge. The second filter holder 162 preferably forms a plurality of windows 163 which are covered by a filter net 164 in a net form.

Assembly of the filter assembly 150 is completed by locking the engagement projections

172a of the first filter unit 170 into the engagement recesses 152a of the filter housing 152, with the second filter unit 160 being disposed between an endwall of the filter housing 152 and the first filter unit 170. The filter assembly 150 is mounted into the filter mounting 101 (see FIGS. 2 or 6) of the main body. However, when the filter assembly 150 is not completely assembled or when  
5 the first filter unit 170 is not fully engaged with the filter housing 152, the safety lever 153 protrudes toward one side of the filter assembly 150 and interrupts the insertion of the filter assembly into filter mounting 101 on one sidewall as shown in FIG. 6, thereby preventing the filter assembly 150 from being inserted into the filter mounting 101. In other words, the safety lever 153 ensures that the device is operational only upon complete assembly of the filter assembly 150.

10 The structure and function of the safety lever 153 will be described in more detail with reference to FIGS. 4 and 5.

As shown in FIG. 4, the safety lever 153 has a locking projection 153a which can be inserted into a hole 156 formed on a sidewall of the filter housing 152. When the first filter unit 170 is engaged with the filter housing 152 in the direction of arrow "C" (FIG. 5), the safety lever 153 with the locking projection 153a is received within the filter housing 152 by the first filter  
15 holder 172.

When the filter assembly 150 is completely assembled as described above, the safety lever 153 is placed within the filter housing 152 so that the filter assembly 150 can be fitted into the filter mounting 101. If the filter assembly 150 is not completely or properly assembled, it

cannot be fitted into the filter mounting 101, thereby preventing incomplete filtering caused by incomplete assembly of the filter assembly 150.

FIGS. 7 to 9 show the process of inserting the filter assembly 150 into the filter mounting 101. FIG. 7 shows the filter assembly 150 before being inserted into the filter mounting 101. FIG. 9 shows the filter assembly 150 after insertion into the filter mounting 101. FIG. 8 shows the inside structure of the filter mounting 101.

Referring to FIG. 7, the filter assembly 150, which is connected to the main body cover 120, is inserted into or removed from the filter mounting 101. It will be described below how to insertion of the filter assembly 150, connected to the main body cover 120, proceeds into the filter mounting 101.

In order to insert the filter assembly 150 into the filter mounting 101, the user should hold the handle 121, provided on the main body cover 120, and slidably insert down a second guide member 152b, formed on the filter assembly 150 (FIG. 7), along the inside of a first guide member 103 formed in the filter mounting 101 (see FIG. 8). Before the filter housing 150 is inserted into the filter mounting 101, an opening cover 158 covers the opening 155 formed on the filter housing 152 due to the elastic force of a spring 159, as shown in FIG. 7.

During the process of the filter assembly 150 being inserted into the filter mounting 101, the lower part of the opening cover 158 is interrupted by the top of a sealing member 102 (see FIG. 8) formed at one side of the filter mounting 101. The protruding top of sealing member 102 causes

the opening corner 158 to lift up in the direction of arrow "D" in FIG. 9, overcoming the recovery force of an associated spring 159 holding the cover 158 closed, to open the opening 155 of the filter housing 152. Thus, when the filter assembly 150 is completely inserted in the filter mounting 101, the opening 155 of the filter housing 152 exactly fits with the air suction hole 104  
5 (see FIG. 8) to provide the capability to connect to the flexible hose 180 (see FIG. 2).

The user can remove the filter assembly 150 out of the filter mounting 101, holding the handle 121 on the main body cover 120, for the purpose of cleaning the filter assembly 150. During the removal process, the opening cover 158 is released from contact with the sealing member 102 and returns to cover the opening 155 of the filter housing 152 by the return force of  
10 the spring 159 (see FIG. 7).

Therefore, as the user simply inserts the filter assembly 150, using the second guide member 152b to engage the inside of the first guide member 103, the opening 155 of the filter assembly 150 will automatically fit with the air suction hole 104 of the main body 100. When separating the filter assembly 150 from the filter mounting 101 to clean the filter assembly 150,  
15 the user needs only to lift up the main body cover 120, holding the handle 121. Then, the opening cover 158 will cover the opening 155 again to prevent dust particles from leaking out of the filter assembly 150 during the time that the filter assembly remains outside of the filter mounting 101.

FIGS. 10 to 12 illustrate the connection between the filter assembly 150 and the main body

cover 120 and a process for completing the connection. FIG. 10 is a partially exploded perspective view of the main body cover 120 and the filter housing 152 for explaining the process for connecting the two elements. FIGS. 11 and 12 are detail views showing the process of connecting the filter housing to the main body cover and the converse process of separating the two elements.

5 As shown in FIG. 10, the main body cover 120 has first to third hooks 122, 123, 124 respectively, disposed at the bottom or endwall thereof. The first hook 122 is formed at the center of one side of the bottom. The second hook 123 and third hook 124 are formed at the other side of the bottom, spaced a predetermined distance apart from each other. The first hook 122 is retained to be biased in the direction of arrow X in FIG. 10 by an elastic spring (not shown).  
10 Also, the filter housing 152 includes an engagement loop 154 disposed on the top thereof and has a plurality of locking jaws 157 formed on one surface at either upper side thereof.

Further, the filter housing 152 forms a support projection 302 and a plurality of lockers 301 for holding a tool for cleaning the filter on one side thereof. In FIG. 10, a brush 300 is illustrated as an example of the cleaning tool.

15 FIG. 11 shows in detail partial cross-section the connected state of the main body cover 120 and the filter housing 152. When the main body cover 120 is pressed toward the filter housing 152 in the direction of arrow F, with the second and third hooks 123, 124 being placed for engagement with the locking jaws 157 (FIG. 10), the first hook 122 can be engaged with the engagement loop 154 as shown in FIG. 11.

The user can easily separate the filter housing 152 from the main body cover 120 by lifting up the first hook 122 in the direction of arrow G in FIG. 12 thereby releasing the first hook 122 from the corresponding engagement loop 154.

As described above, the main body cover 120 and the filter housing 152 are easily  
5 connected and separated. Thus, the user can easily insert and remove the filter assembly 150 into and from the filter mounting 101 using the handle 121, without dirtying his or her hands. FIG. 13 shows the main body 100 for explaining the connection of the handle 121 provided on the main  
body cover 120 to the main body 100. As shown in FIG. 13, a fourth hook 105 and a fifth hook  
106 are formed at both sides of the handle 121, and two corresponding grooves 107 are formed at  
10 corresponding positions on the main body 100. If the filter assembly 150 is inserted in the filter mounting 101 and the handle 121 provided on the main body cover 120 is pushed down, the fourth and fifth hooks 105, 106 will be locked into the grooves 107, thereby connecting the handle 121 to the main body 100 in an out of the way position.

Since the handle 121 is connected to the main body 100, the main body cover 120 will not  
15 be separated from the main body 100 even if the main body 100 is suddenly rotated during operation.

Although a preferred embodiment of the present invention has been described for illustrative purposes, those skilled in the art will appreciate that various modifications, additions and substitutions are possible, without departing from the scope and spirit of the invention as set forth in the accompanying claims.

## WHAT IS CLAIMED IS:

1. A bagless vacuum cleaner comprising:

a brush;

a driving motor for generating a suction force;

5 a main body including said driving motor and a filter mounting;

a dust suction tube having one end connected to said filter mounting and the other end  
connected to said brush;

a filter assembly mounted within said filter mounting to filter out dust from external air  
drawn into said main body through said dust suction tube and said brush; and

10 a main body cover coupled with said filter assembly to facilitate the insertion and removal  
of said filter assembly into and from said filter mounting and being capable of locking to said main  
body.

2. The bagless vacuum cleaner according to claim 1, wherein said filter assembly

15 further comprises:

a filter housing having an opening;

a first filter unit connected within said filter housing; and

a second filter unit placed between an endwall of said filter housing and said first filter  
unit.

3. The bagless vacuum cleaner according to claim 2, wherein said filter housing includes an engagement loop connected to said main body cover and a safety lever for preventing said filter assembly from being mounted into said filter mounting when said first filter unit is not fully connected within said filter housing.

5

4. The bagless vacuum cleaner according to claim 2, wherein said filter housing further comprises an opening cover for selectively opening and closing said opening.

5. The bagless vacuum cleaner according to claim 3, wherein said filter housing further comprises an opening cover for selectively opening and closing said opening.

10

6. The bagless vacuum cleaner according to claim 2, wherein said second filter unit comprises a second filter, a second filter holder for supporting said second filter, and a filter net enclosing said second filter within said second filter holder.

15

7. The bagless vacuum cleaner according to claim 2, wherein said first filter unit further comprises a first filter and a first filter holder for supporting said first filter.

8. A bagless vacuum cleaner comprising:

a brush;

a driving motor for generating a suction force;

a main body including said driving motor and a filter mounting;

5 a dust suction tube having one end connected to said filter mounting and the other end connected to said brush;

a cyclone dust collector provided in said dust suction tube for separating said dust from air drawn into the collector by circulating the air within the cyclone dust collector;

10 a filter assembly mounted into said filter mounting and comprising a filter housing, a first filter unit and a second filter unit to filter out dust and dirt from external air drawn into said main body through said dust suction tube and said brush; and

a main body cover having first, second and third hooks, each of which are shaped and configured to engage said filter assembly, and a handle for facilitating the selective insertion and removal of said filter assembly into and from said filter mounting.

15

9. The bagless vacuum cleaner according to claim 8, wherein said handle of said main body cover has at least one hook which can be locked into corresponding locking grooves formed on said main body.

10. The bagless vacuum cleaner according to claim 8, wherein said filter assembly further comprises a safety lever.

11. The bagless vacuum cleaner according to claim 8, wherein said filter housing of  
5 said filter assembly includes an opening, which exactly corresponds with said dust suction tube, and an opening cover for selectively opening and closing said opening.

12. The bagless vacuum cleaner according to claim 9, wherein said filter housing of  
said filter assembly includes an opening, which corresponds with said dust suction tube, and an  
10 opening cover for selectively opening and closing said opening.

13. The bagless vacuum cleaner according to claim 8, wherein said filter housing of  
said filter assembly includes an engagement loop, which is shaped and configured to engage with  
said first hook of said main body cover, and a plurality of locking jaws, which can be engaged  
15 with said second and third hooks of said main body cover.

14. A bagless vacuum cleaner comprising:

a brush;

a driving motor for generating a suction force;

30235-12

a main body including said driving motor and a filter mounting having a filter guide;

a dust suction tube having one end connected to said filter mounting and the other end connected to said brush;

5 a cyclone dust collector provided in said dust suction tube to remove dust from air drawn into the cyclone dust collector by circulating the air within the cyclone dust collector;

a filter assembly mounted within said filter mounting and comprising a filter housing and a first filter unit locked into said filter housing; and

a main body cover detachable from said filter assembly, said main body being provided with a handle.

10

15 15. The bagless vacuum cleaner according to claim 14, wherein said handle of said main body cover has a plurality of hooks which can be locked into corresponding locking grooves formed on said main body.

15

16. The bagless vacuum cleaner according to claim 14, wherein said filter assembly includes a support projection and at least one locker capable of holding a tool for cleaning said filter on one side thereof.

Fetherstonhaugh & Co.  
Ottawa, Canada  
Patent Agents

**FIG. 1**  
*(Prior Art)*

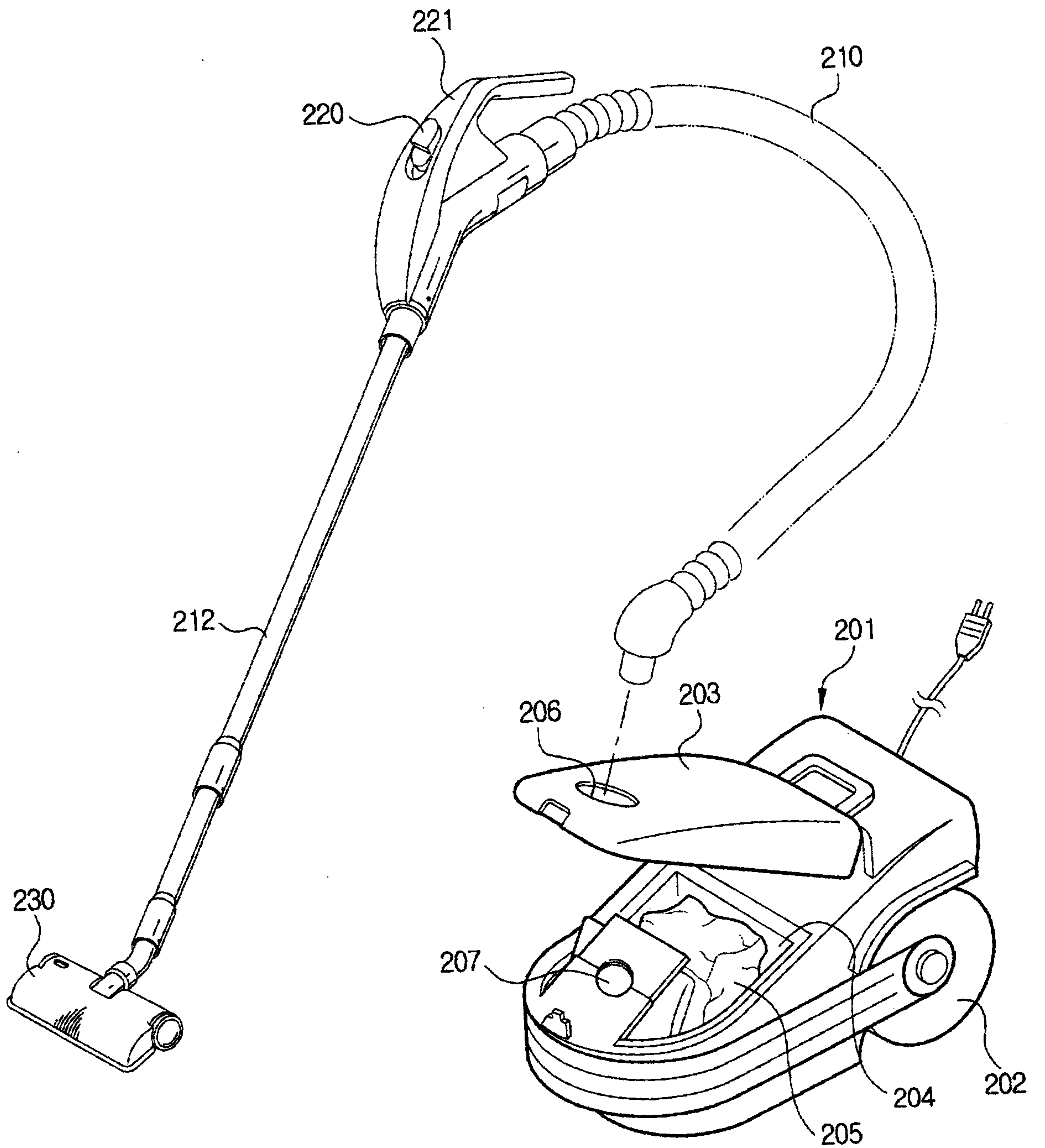
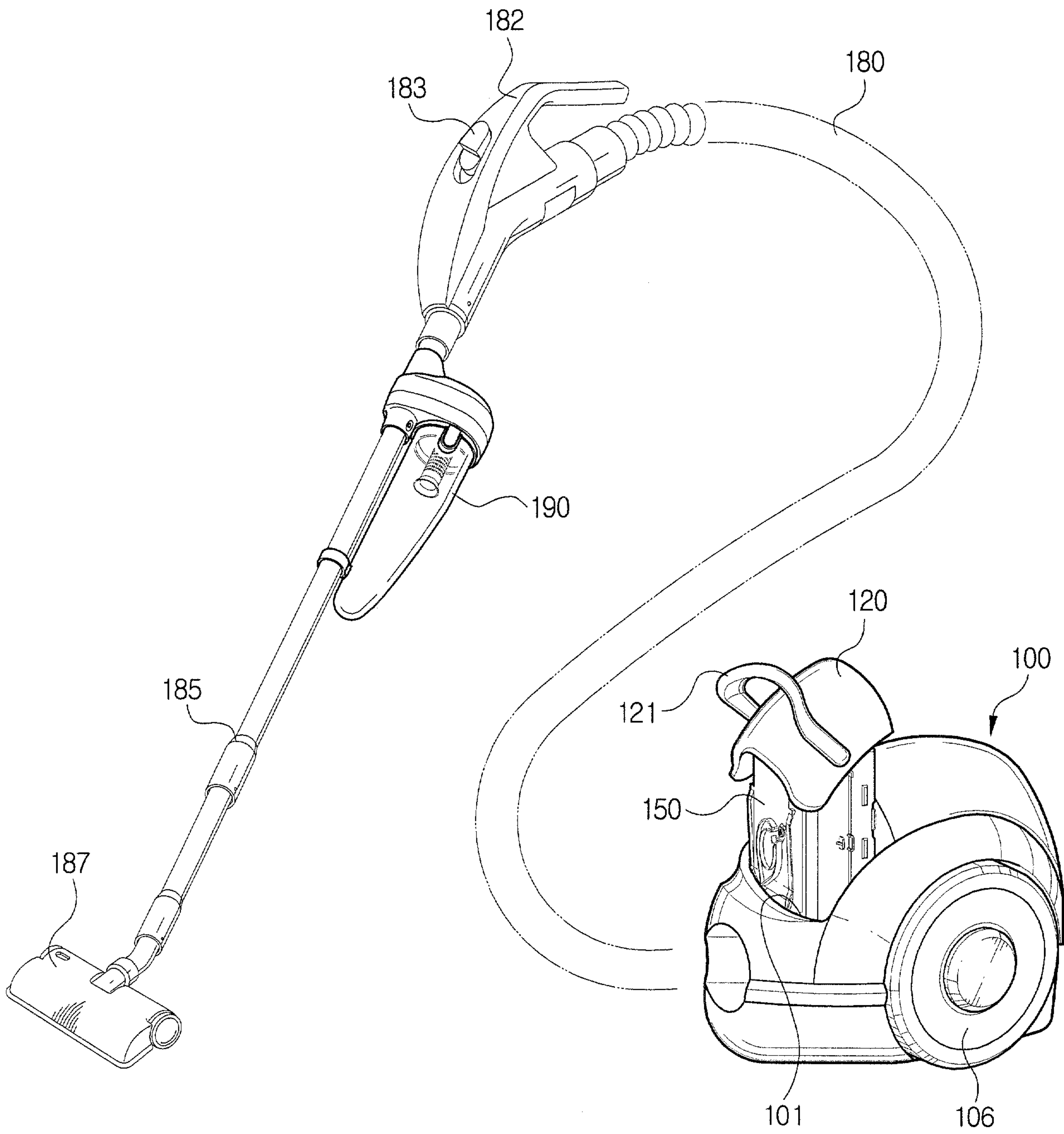
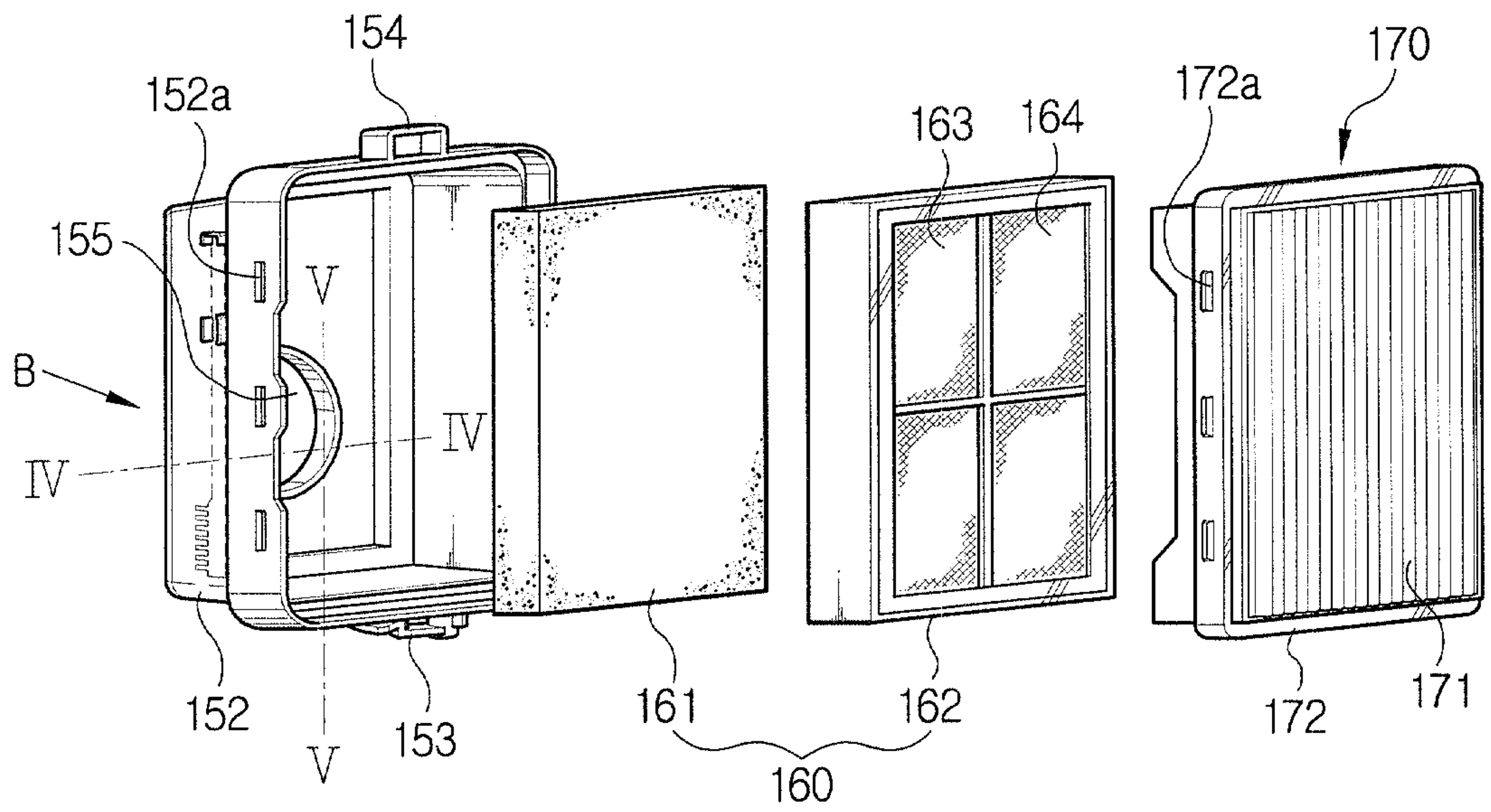

FIG. 2



# FIG. 3



# FIG. 4

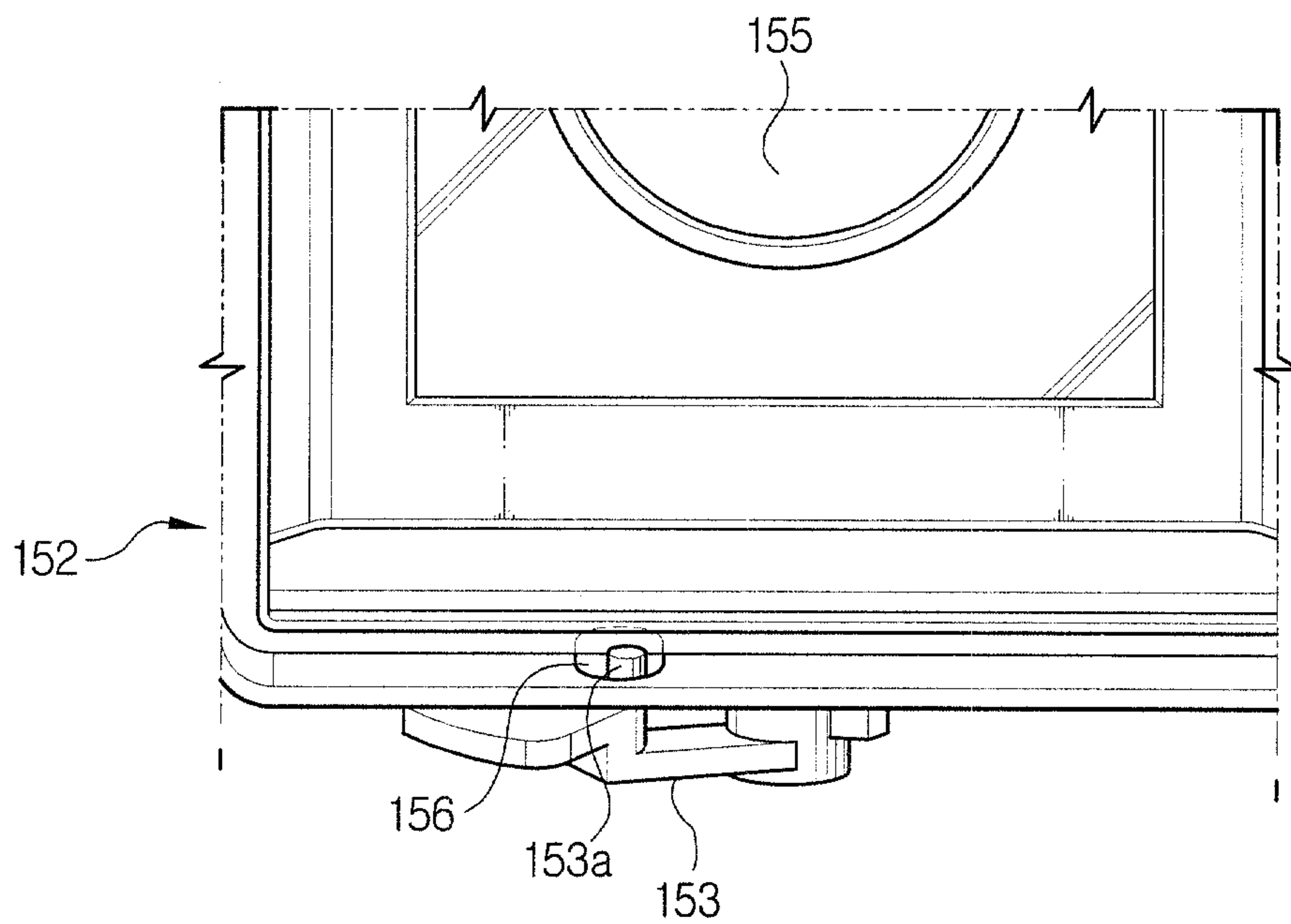

FIG. 5

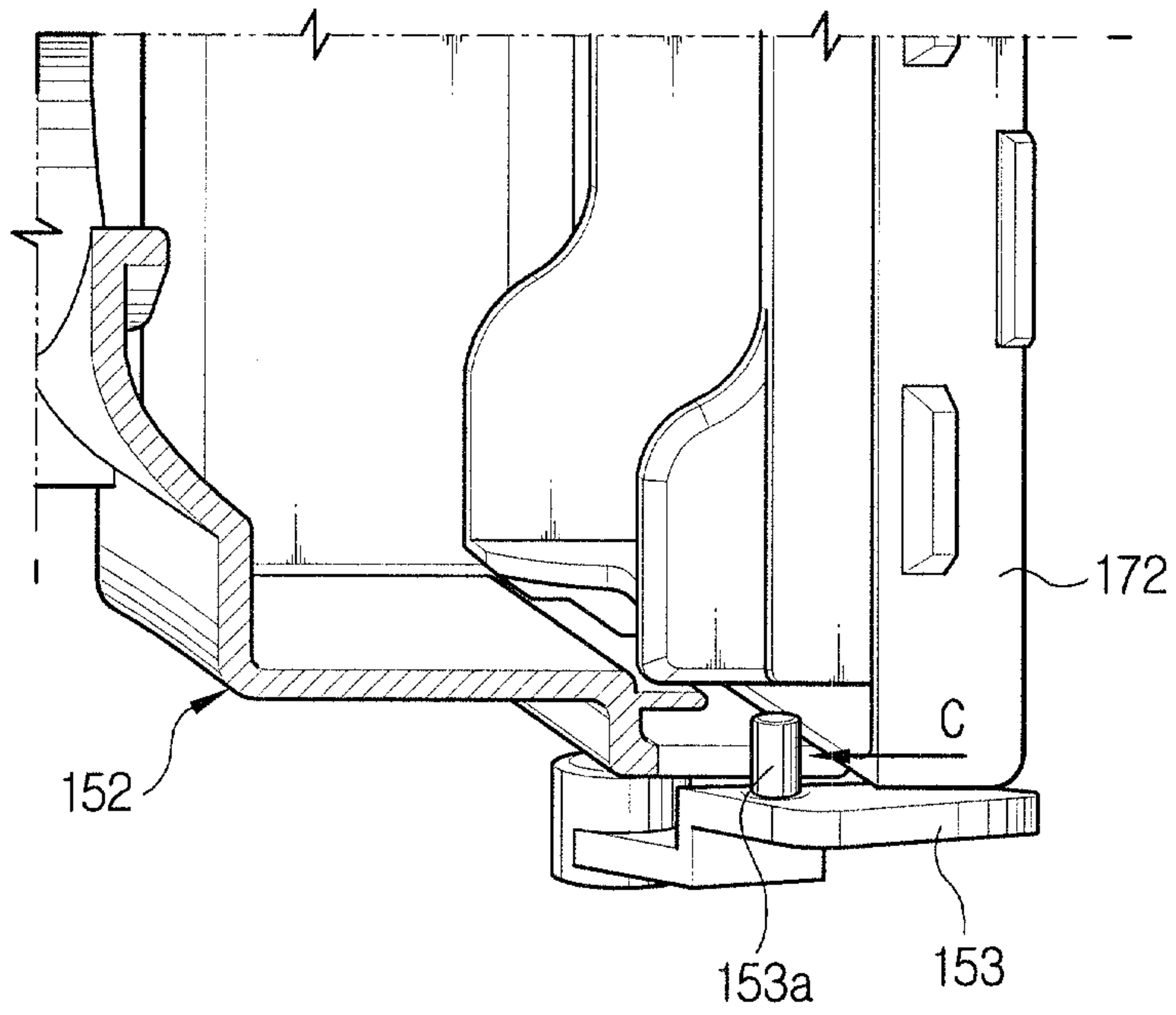
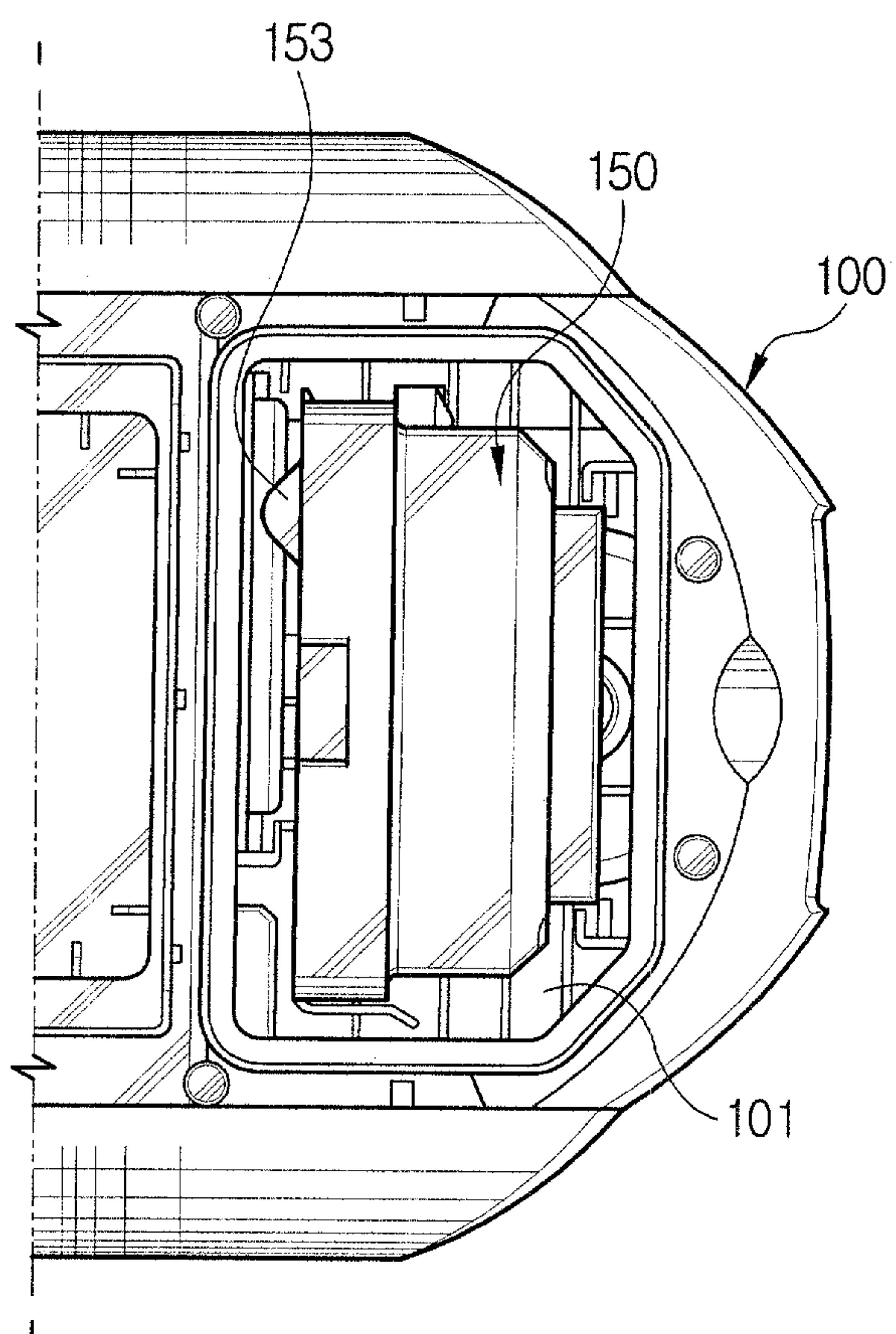
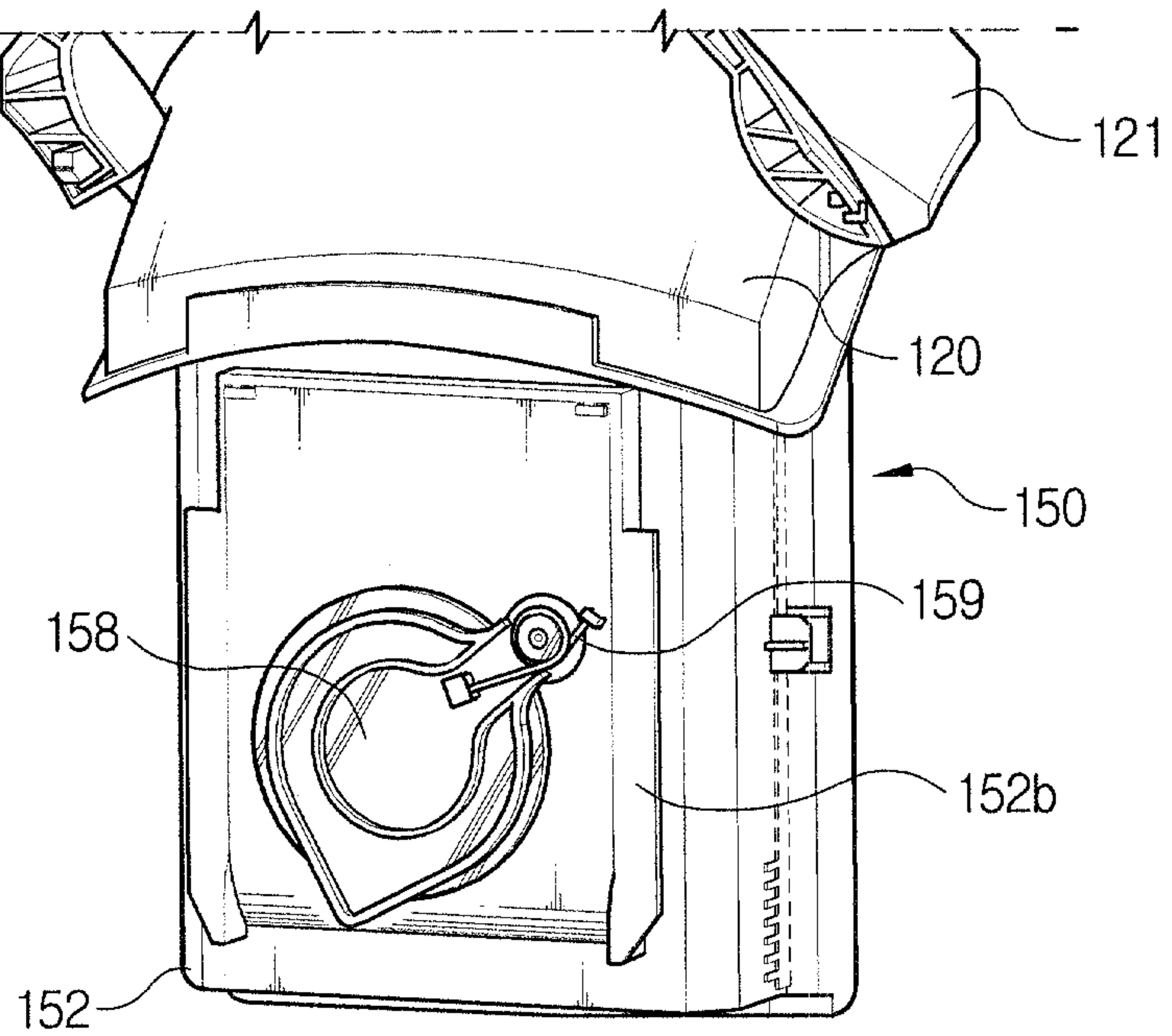

FIG. 6



# FIG. 7



# FIG. 8

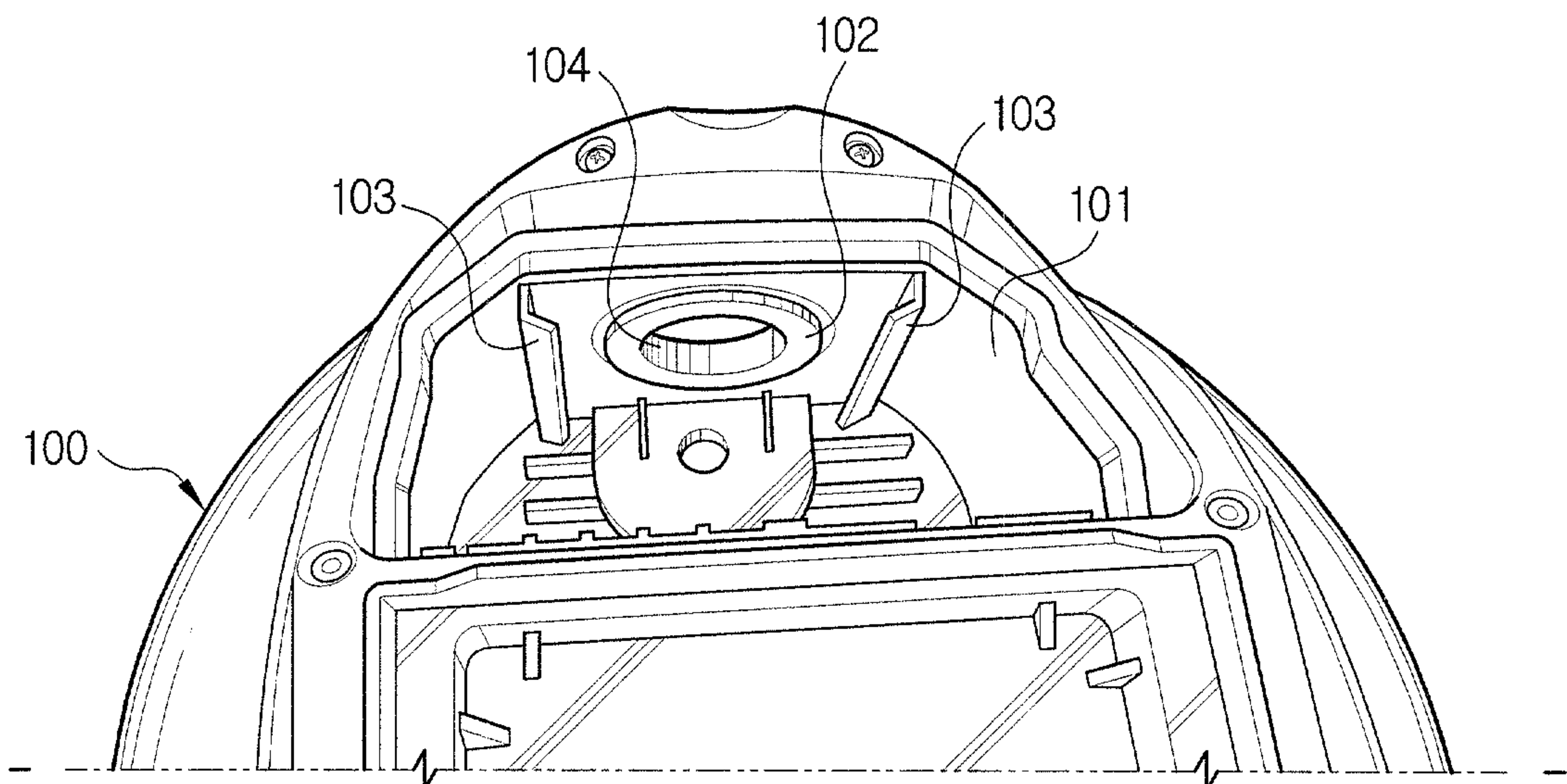
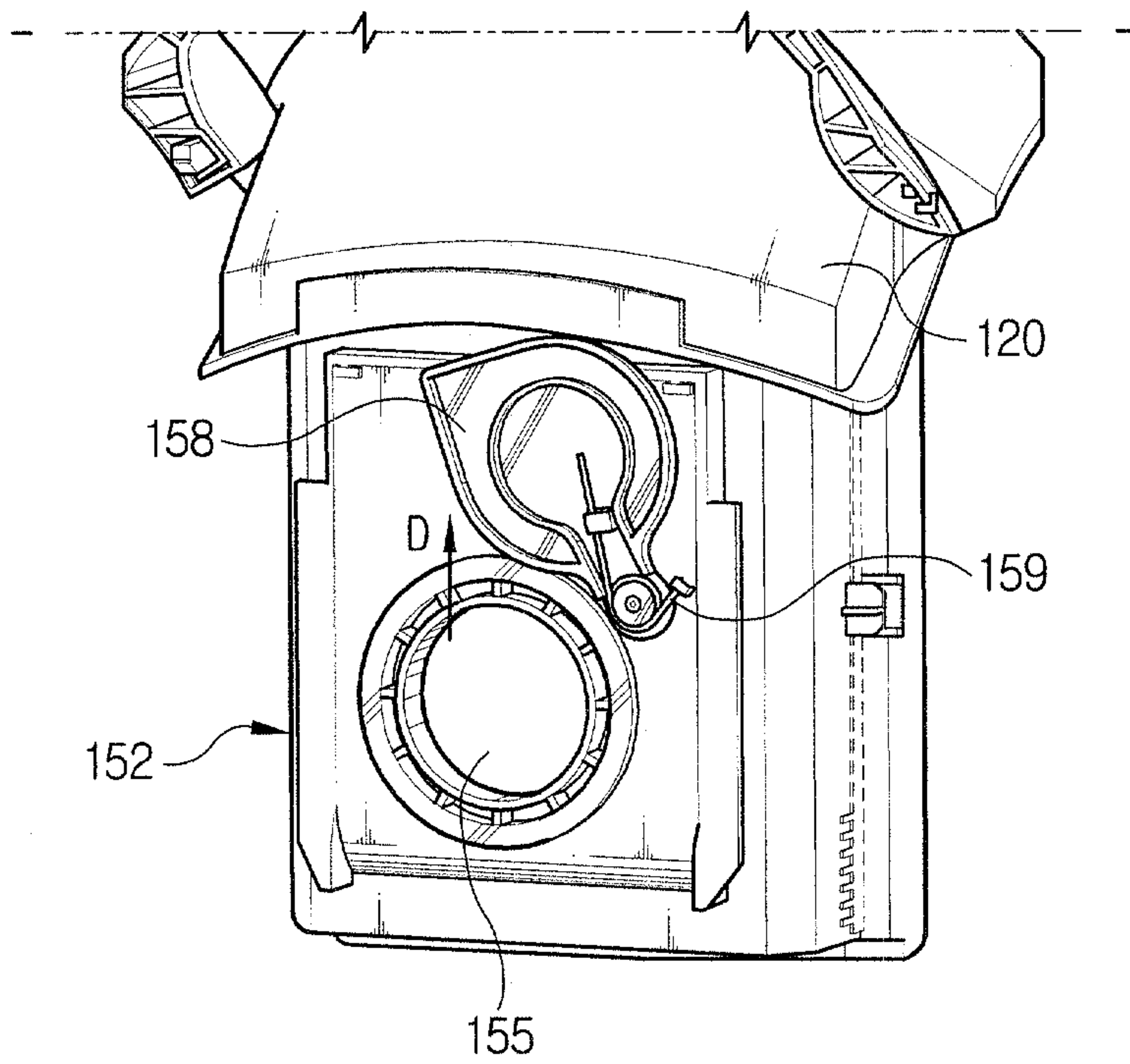

FIG. 9



# FIG. 10

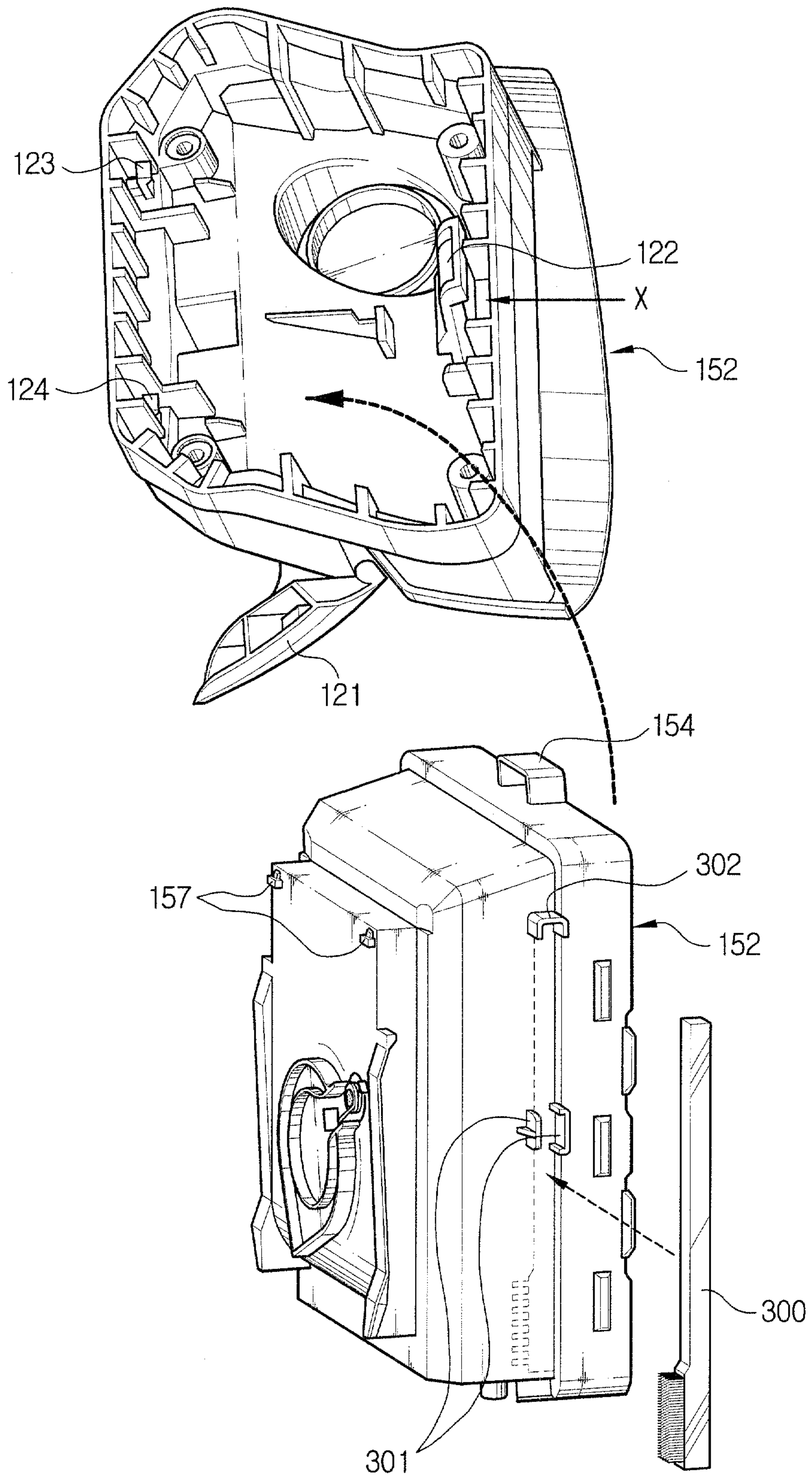

FIG. 11

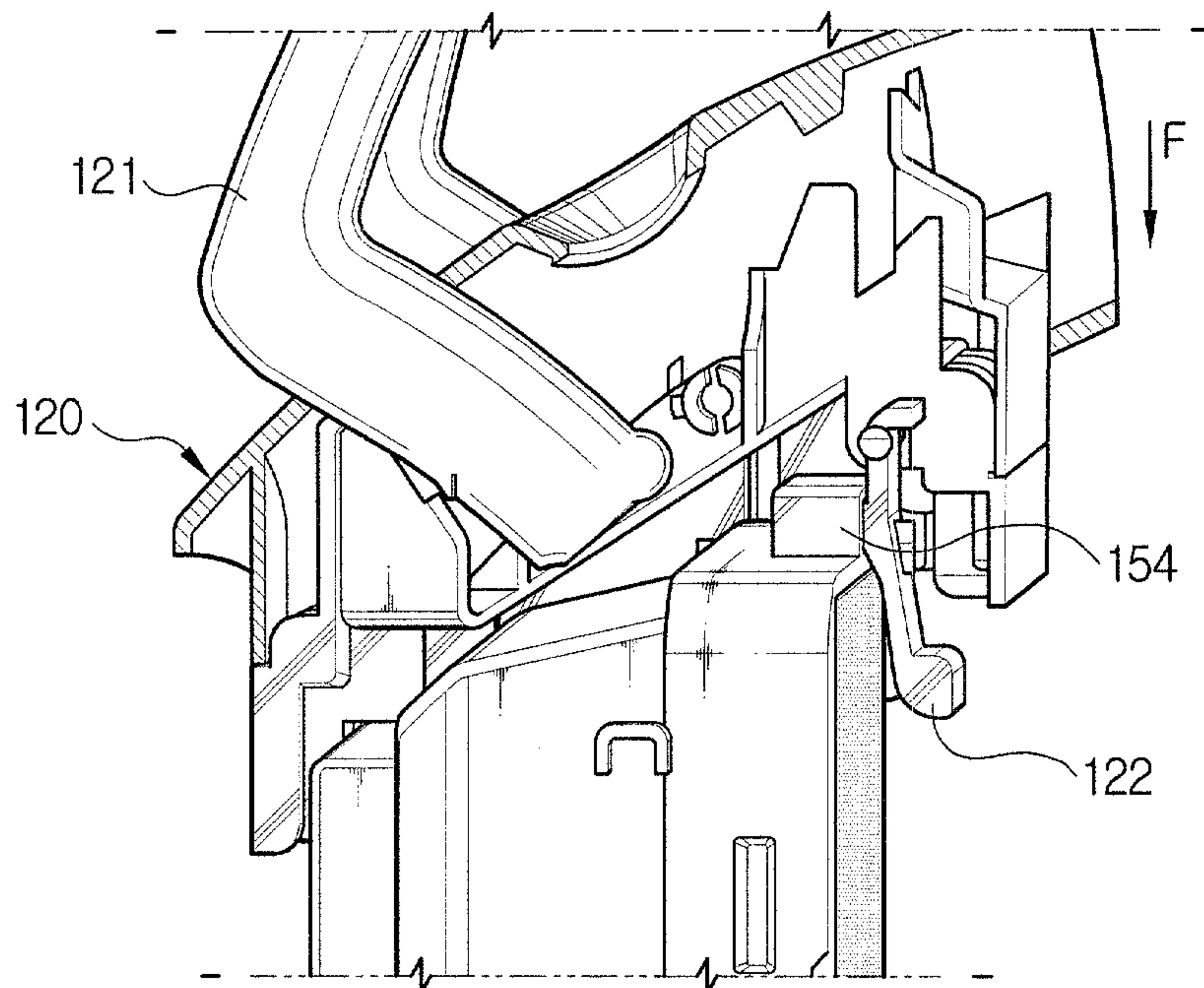

FIG. 12

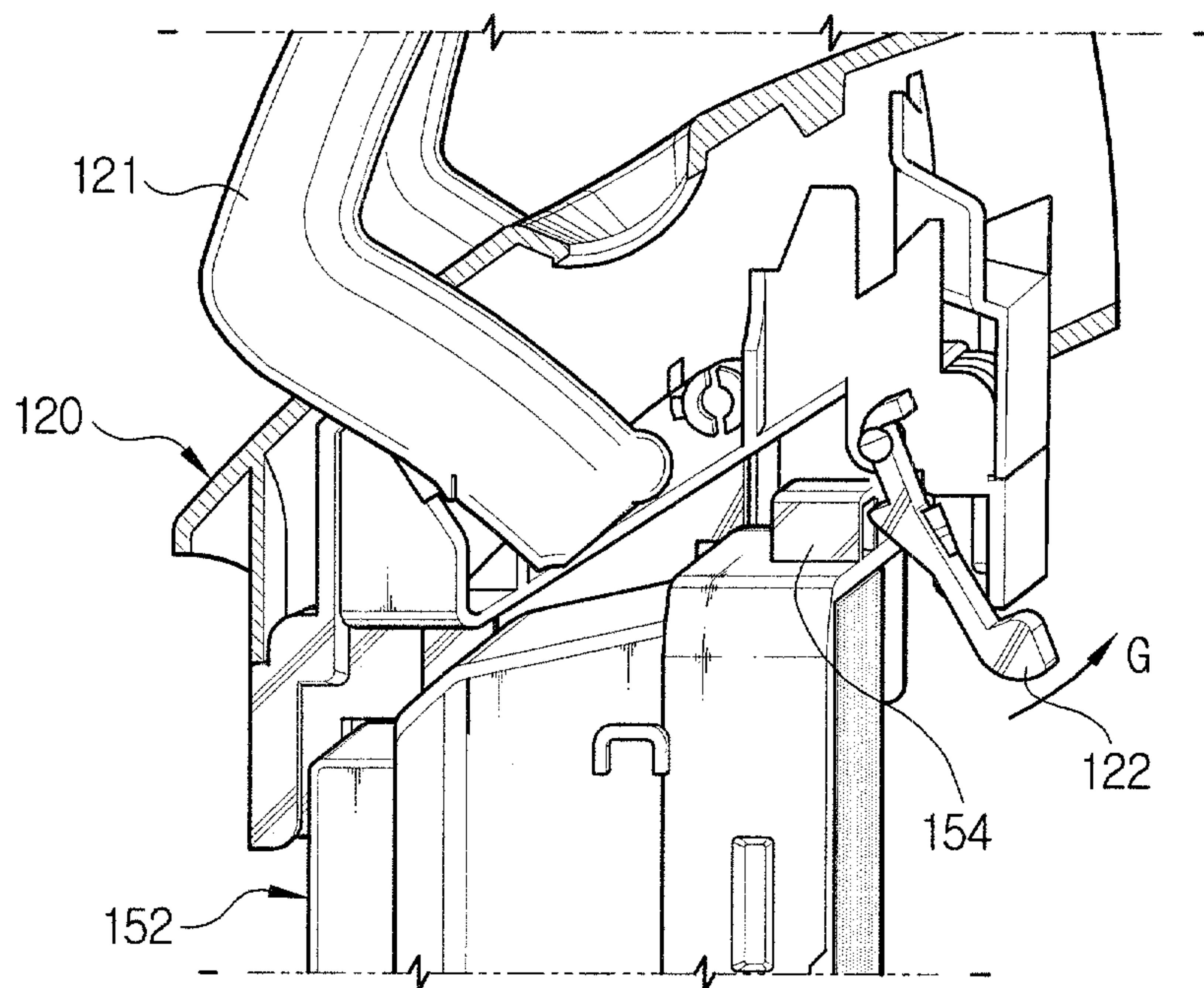

FIG. 13

