

(No Model.)

# C. B. HITCHCOCK.

## VALVE.

No. 284,635.

Patented Sept. 11, 1883.

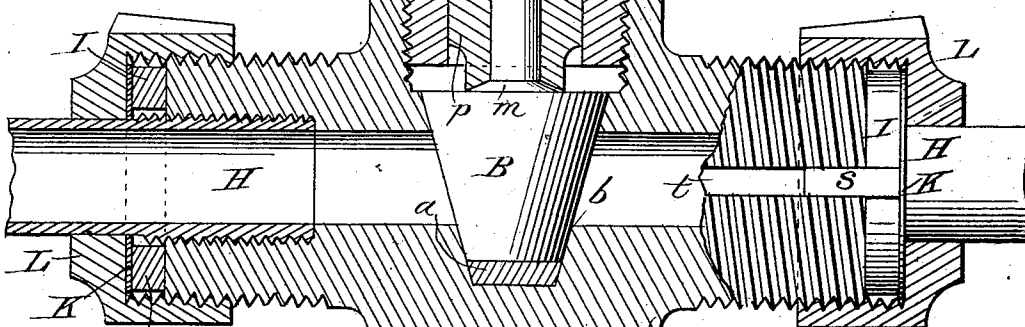
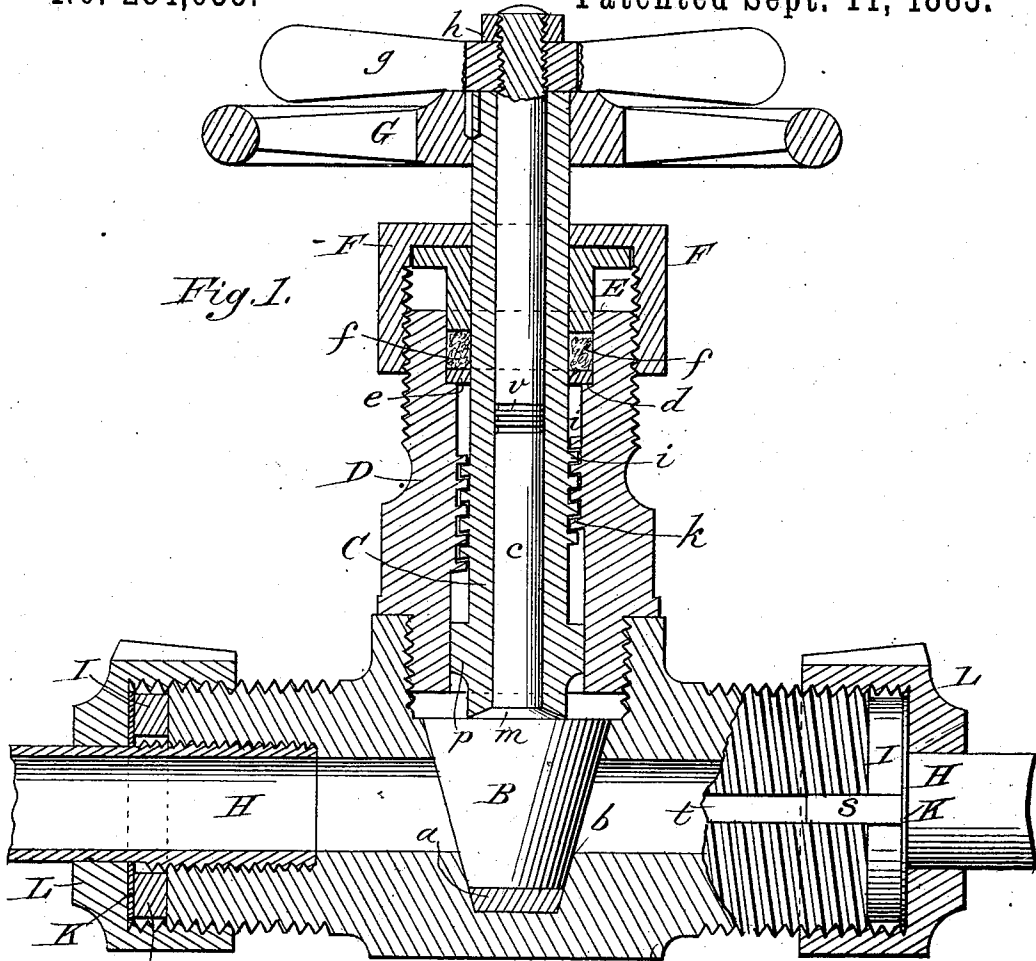

Attest:  
*A. H. Schott*  
*A. R. Brown*

Inventor:  
*Charles B. Hitchcock*  
*per J. C. Tasker*

# UNITED STATES PATENT OFFICE.

CHARLES B. HITCHCOCK, OF INDIANAPOLIS, INDIANA.

## VALVE.

SPECIFICATION forming part of Letters Patent No. 284,635, dated September 11, 1883.

Application filed May 8, 1883. (No model.)

*To all whom it may concern:*

Be it known that I, CHARLES B. HITCHCOCK, a citizen of the United States, residing at Indianapolis, in the county of Marion and State of Indiana, have invented certain new and useful Improvements in Valves; and I do declare the following to be a full, clear, and exact description of the invention, such as will enable others skilled in the art to which it appertains to make and use the same, reference being had to the accompanying drawings, and to the letters and figures of reference marked thereon, which form a part of this specification.

This invention relates to certain improvements in valves for steam, gas, ammonia, or other fluids; and it consists in the construction and arrangement of parts, as hereinafter more fully described and claimed.

In the annexed drawings, illustrating the invention, Figure 1 is a sectional view of my improved valve. Fig. 2 is an end view of the valve-casing. Fig. 3 is a perspective view of an armed metal washer. Fig. 4 is a plan view of nut. Fig. 5 is a view of rubber washer.

Like letters indicate like parts in the several views.

A is a valve-casing of the ordinary T form, as shown in Fig. 1. This valve-casing is provided with a conical valve-seat, at the bottom of which is placed a rubber packing-piece, *a*.

B is a solid conical valve or plug, which is fitted to its valve-seat *b* in the casing A, and has a stem or rod, *c*, that is surrounded by a sleeve, C, which is inclosed in a pipe, D, that forms a branch or extension of the valve-casing A, and has a screw-threaded connection therewith, as illustrated in Fig. 1. The branch or extension D of the valve-casing is shouldered at *d* to form a support for a washer, *e*, upon which is placed any suitable packing, *f*, a gland, E, being introduced partly into the end of the branch D, above the packing *f*, and forced home by a cap or nut, F, that is screwed onto the upper end of said branch, the parts E and F thus forming a stuffing-box. By this construction a tight joint is obtained that effectually prevents the passage of any fluid

under pressure. It will also be observed that the gland E is simply slipped into the end of the branch D, above the packing *f*, where it is firmly held by the stuffing-box cover F, the advantage of which, in addition to securing an impervious packing, consists, also, in the fact that the packing *f* is thus preserved from the wearing or abrading action of the gland E that would result if the latter were screwed down upon said packing.

A hand-wheel, G, is keyed to the sleeve C, and the valve-stem *c* is provided with a handle, *g*, that is secured by a check-nut, *h*, as shown in Fig. 1. The sleeve C is provided on its exterior with screw-threads, *i*, that take into corresponding threads, K, formed in the interior of the branch D, as shown. It will thus be seen that when the hand-wheel G is turned, thereby rotating the sleeve C, which is interposed between the valve-plug B and the handle *g* of its stem *c*, the valve-plug will be raised or lowered according to the direction in which said hand-wheel is turned, thus opening or closing the passage-way through the valve-casing. If the plug B, by long use, should become worn in spots, so as not to fit its seat sufficiently close to prevent the leakage over or below the plug of gas, steam, or other fluid—such as ammonia—the plug may be turned about one-quarter by means of its stem *c* and handle *g*, so as to carry the imperfect portion of the valve-plug away from the parts of the valve-seat, thus obviating liability of leakage from corrosion or wearing of the valve. The upper portion of the valve-plug B, at the junction with its stem, is ground to a conical surface or projection at *m*, which projection fits into a conical or beveled seat in the end of the sleeve C, thus forming a close-fitting joint that prevents the escape of steam, gas, ammonia, or other fluid through the sleeve and in contact with the valve-stem. As already observed, all liability of leakage exterior to the sleeve C, between it and the branch D, is prevented by the washer *e*, packing *f*, and gland E, as well as by a shouldered enlargement or collar, *p*, on the exterior of the sleeve, near its lower end, this collar also serving to steady the sleeve in operating the valve.

It will be observed that the branch D is connected to the valve-casing A above the seat of the valve-plug B in such a manner as to leave a space above said valve-plug when closed down into its seat and upon the packing *a'*. The valve-plug is projected into this space when raised, to permit a passage of fluid through the valve-case, the valve being opened by raising the plug, to afford a passage for liquid around said plug, and closed by lowering the plug into its seat, to cut off the flow of liquid. It will also be observed that when the valve-plug is fully raised it is seated closely against the lower end of the branch D in such a manner as to prevent leakage between the branch and sleeve, as well as between the sleeve and valve-stem. By this construction, the valve-plug being solid, no fluid is retained therein when the valveway is closed, as would occur if the valve-plug were perforated and arranged to open and close by rotation, instead of by raising and lowering. The liability of injury to the plug by corrosion is lessened, and all tendency to damage by the freezing of confined liquids, which is common with a perforated plug, is thus avoided.

Each end of the valve-casing is threaded internally, to receive the threaded end of a pipe-connection, H, over which is passed a rubber packing-ring, I, Fig. 5, that abuts against the end of the valve-casing. This rubber packing-ring is held in place by an armed washer, K, Fig. 3, composed of a flat annular metallic plate having arms *s s*, that enter grooves *t t*, formed in the valve-casing, as shown in Figs. 1 and 2, a nut, L, Fig. 4, being screwed over the externally-threaded end of the valve-casing, so as to force the washer K firmly in contact with the rubber packing I, thereby expanding the same laterally in close contact with the pipe H and forming a tight joint at the end of the valve-casing.

This valve, while capable of being employed with great advantage in various situations where a valve is required, is designed especially for use in ammonia-machines, or apparatus for making ice, in which a large waste of ammonia has heretofore been experienced through the inability of valves as ordinarily constructed to resist the great pressure to which they are subjected. It will be observed that, owing to the form and manner of operating the valve-plug, as well as the close connection of the valve-casing with the pipe H, as described, all liability of the escape of ammonia under pressure is avoided. It may be remarked that, in order to still further guard against the passage of ammonia in contact with the valve-stem *c*, said stem may be provided with annular grooves *v v*, as shown in Fig. 1. Before putting the parts of the valve together, this valve-stem may be dipped in any lubricating-oil, so as to fill said grooves *v v*, the oil held by said grooves coming in contact with any escaping ammonia and forming a

saponaceous mixture that prevents further waste.

I am aware that the stem of a valve has heretofore been inclosed in a threaded sleeve that takes into a threaded branch of the valve-casing in such manner that a joint is formed between the stem and the end of the sleeve. This, however, I do not broadly claim. Such valves, as heretofore constructed, are liable to permit the escape of fluid between the branch and the sleeve—an accident which is obviated by so constructing the parts that when the valve-plug B is raised it will seat against the lower end of the branch D, thus preventing the escape of fluid between the sleeve and branch and the sleeve and stem, while the close connection of the valve-plug B and its bevel-projection *m* with the lower recessed end of the sleeve C is a further safeguard against the passage of fluid between the sleeve and stem.

It will be understood that I do not herein claim the expansible joints or connections between the valve-casing A and pipes H H, such being reserved for a future application.

Having thus described my invention, what I claim as new, and desire to secure by Letters Patent, is—

1. In combination with the valve-case and its branch and stuffing-box, the stem *c*, having the plug B formed integrally therewith, and provided with the conical enlargement at its junction with said plug, the sleeve C, having the conical depression at its lower end, the handle *g*, and the check-nut *h*, whereby tight joints at the junction of the plug and sleeve and at the top of the sleeve are provided, substantially as set forth.

2. In combination with the valve-case, having a conical seat provided with a packing at the bottom thereof, the conical plug B, extending across the fluidway, and having the stem *c* formed integrally therewith, and provided at the junction of the plug and stem with a convexed or beveled enlargement, and the sleeve C, provided at its lower end with a concaved or beveled depression adapted to receive the enlargement on the valve-stem, and means for the rotary adjustment of said stem and plug, substantially as shown, and for the purposes stated.

3. In a valve provided with means whereby the bearing-surfaces of the valve-plug may be shifted with relation to its seat, the stem *c*, provided with the grooves *v*, for the reception of a lubricant to serve as a packing, as an auxiliary preventive against leakage of the fluid which is controlled by the valve, substantially as shown and described.

4. In combination with the valve-case and the branch D, screw-threaded as shown, the sleeve C, screw-threaded as shown, and provided with the enlargement *p*, the washer *e*, packing *f*, and stuffing-box, substantially as and for the purposes stated.

5 5. In combination with the valve-case and the branch D, the lower end of which forms a flat seating-surface, the plug B, having a flat top and the stem *c*, formed integrally therewith, and the sleeve C, the construction being such that the valve-plug, when raised, seats against the lower end of the branch D, and thus prevents the escape of fluid between

the sleeve and branch and the sleeve and stem, substantially as shown and described. 10

In testimony whereof I affix my signature in presence of two witnesses.

CHARLES B. HITCHCOCK.

Witnesses:

WM. H. BATES,

J. W. HAMILTON JOHNSON.