

(19) World Intellectual Property Organization  
International Bureau



(43) International Publication Date  
4 May 2006 (04.05.2006)

PCT

(10) International Publication Number  
**WO 2006/047394 A1**

- (51) International Patent Classification:  
C12N 15/11 (2006.01) C12N 5/10 (2006.01)  
A61K 48/00 (2006.01)
- (21) International Application Number:  
PCT/US2005/038139
- (22) International Filing Date: 21 October 2005 (21.10.2005)
- (25) Filing Language: English
- (26) Publication Language: English
- (30) Priority Data:  
60/621,416 22 October 2004 (22.10.2004) US
- (71) Applicant (for all designated States except US): **BEN-ITEC, INC.** [US/US]; 2375 Garcia Avenue, Mountain View, CA 94043 (US).
- (72) Inventors; and
- (75) Inventors/Applicants (for US only): **REED, Kenneth, Clifford** [AU/AU]; 12 Fifth Avenue, St Lucia South, Queensland 4067 (AU). **BRASHEARS, Sarah** [US/US]; 3524 Notre Dame Drive, Santa Clara, CA 95051 (US).
- (74) Agents: **PATTERSON, B., Todd** et al.; Patterson & Sheridan, L.L.P., 3040 Post Oak Boulevard, Suite 1500, Houston, TX 77056-6582 (US).

- (81) Designated States (unless otherwise indicated, for every kind of national protection available): AE, AG, AL, AM, AT, AU, AZ, BA, BB, BG, BR, BW, BY, BZ, CA, CH, CN, CO, CR, CU, CZ, DE, DK, DM, DZ, EC, EE, EG, ES, FI, GB, GD, GE, GH, GM, HR, HU, ID, IL, IN, IS, JP, KE, KG, KM, KP, KR, KZ, LC, LK, LR, LS, LT, LU, LV, LY, MA, MD, MG, MK, MN, MW, MX, MZ, NA, NG, NI, NO, NZ, OM, PG, PH, PL, PT, RO, RU, SC, SD, SE, SG, SK, SL, SM, SY, TJ, TM, TN, TR, TT, TZ, UA, UG, US, UZ, VC, VN, YU, ZA, ZM, ZW.
- (84) Designated States (unless otherwise indicated, for every kind of regional protection available): ARIPO (BW, GH, GM, KE, LS, MW, MZ, NA, SD, SL, SZ, TZ, UG, ZM, ZW), Eurasian (AM, AZ, BY, KG, KZ, MD, RU, TJ, TM), European (AT, BE, BG, CH, CY, CZ, DE, DK, EE, ES, FI, FR, GB, GR, HU, IE, IS, IT, LT, LU, LV, MC, NL, PL, PT, RO, SE, SI, SK, TR), OAPI (BF, BJ, CF, CG, CI, CM, GA, GN, GQ, GW, ML, MR, NE, SN, TD, TG).

**Published:**  
 — with international search report  
 — before the expiration of the time limit for amending the claims and to be republished in the event of receipt of amendments

For two-letter codes and other abbreviations, refer to the "Guidance Notes on Codes and Abbreviations" appearing at the beginning of each regular issue of the PCT Gazette.

(54) Title: THERAPEUTIC RNAI AGENTS FOR TREATING PSORIASIS

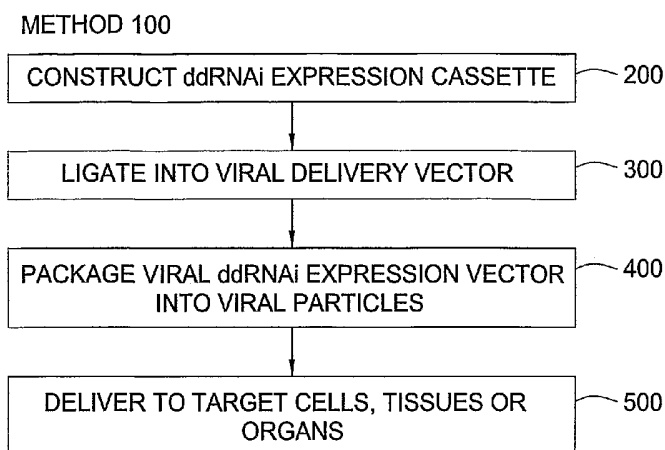

(57) Abstract: The present invention provides compositions and methods suitable for delivering RNAi agents against genetic targets in skin tissues so as to treat psoriasis.

WO 2006/047394 A1

## THERAPEUTIC RNAi AGENTS FOR TREATING PSORIASIS

### BACKGROUND OF THE INVENTION

[0001] Utilization of double-stranded RNA to inhibit gene expression in a sequence-specific manner has revolutionized the drug discovery industry. In mammals, RNA interference, or RNAi, is mediated by 15- to 49-nucleotide long, double-stranded RNA molecules referred to as small interfering RNAs (RNAi agents). RNAi agents can be synthesized chemically or enzymatically outside of cells and subsequently delivered to cells (see, e.g., Fire, et al., Nature, 391:806-11 (1998); Tuschl, et al., Genes and Dev., 13:3191-97 (1999); and Elbashir, et al., Nature, 411:494-498 (2001)); or can be expressed *in vivo* by an appropriate vector in cells (see, e.g., US Pat. No. 6,573,099).

[0002] *In vivo* delivery of unmodified RNAi agents as an effective therapeutic for use in humans faces a number of technical hurdles. First, due to cellular and serum nucleases, the half life of RNA injected *in vivo* is only about 70 seconds (see, e.g., Kurreck, Eur. J. Bioch. 270:1628-44 (2003)). Efforts have been made to increase stability of injected RNA by the use of chemical modifications; however, there are several instances where chemical alterations led to increased cytotoxic effects. In one specific example, cells were intolerant to doses of an RNAi duplex in which every second phosphate was replaced by phosphorothioate (Harborth, et al., Antisense Nucleic Acid Drug Rev. 13(2): 83-105 (2003)). Still efforts continue to find ways to delivery unmodified or modified RNAi agents so as to provide tissue-specific delivery, as well as deliver the RNAi agents in amounts sufficient to elicit a therapeutic response but that are not toxic.

[0003] Other options being explored for RNAi delivery include the use of viral-based and non-viral based vector systems that can infect or otherwise transfect target cells, and deliver and express RNAi molecules *in situ*. Often, small RNAs are transcribed as short hairpin RNA (shRNA) precursors from a viral or non-viral vector backbone. Once transcribed, the shRNA are processed by the enzyme Dicer into

the appropriate active RNAi agents. Viral-based delivery approaches attempt to exploit the targeting properties of viruses to generate tissue specificity and once appropriately targeted, rely upon the endogenous cellular machinery to generate sufficient levels of the RNAi agents to achieve a therapeutically effective dose.

[0004] One useful application of RNAi therapeutics is to treat or prevent psoriasis. Psoriasis is a common skin condition, affecting about 3% of the population. It can occur constantly or in bouts, following triggers such as stress and skin damage, most often appearing in humans between the ages of 10 and 30 years. Although the cause of psoriasis is unknown, there are heredity factors in the majority of cases.

[0005] Psoriasis causes the thickening and scaling of the skin due to an increased rate of skin turnover and regeneration. Also the capillaries (small blood vessels under the skin) expand, making the skin appear red and inflamed. Flakes of skin may fall off the scalp, which can be mistaken for dandruff. In addition, about 5% of patients will also suffer painful joints (arthritis) or spine (ankylosing spondylitis).

[0006] Epidermal hyperproliferation is a major characteristic of psoriasis. The underlying cause of the aberrant keratinocyte growth control is thought to be the presence of activated T lymphocytes at the dermal/epidermal interface (Kreuger et al., J. Invest. Dermatol. 94: 135s-140s, (1990); Nickoloff, Arch. Dermatol. 127: 871-884, 1991; Gottlieb, Arch. Dermatol. 133: 781-782, (1997)). The effects of uncontrolled epidermal growth can be severe, and include a loss of normal epidermal barrier function, cosmetic disfigurement, and discomfort caused by the shedding of epidermal flakes. Histologically, psoriatic epidermal hyperproliferation is characterized by an overrepresentation of basaloid keratinocytes (Leigh, et al., Br. J. Dermatol. 113: 53-64, (1985)), abnormally thick epidermal layer, or acanthosis, and the persistence of cell nuclei into the upper cornified layer (parakeratosis). Keratinocyte transit time through the epidermis is accelerated 10-fold compared with normal skin (Van Scott and Ekel, Arch Dermatol. 88: 373-381, (1963)), and differentiated characteristics do not develop.

[0007] There are a number of factors which can stimulate or worsen psoriasis. These includes skin infection, physical and emotional stress, and sunburn. In addition, there are a number of drugs which also adversely affect psoriasis, including some antimalaria drugs, beta-blockers, lithium, NSAIDS, and oral contraceptives.

[0008] Current treatments for psoriasis generally include treatments based on:

[0009] (i) Tar: Coal tar is known to assist in psoriasis treatment and is available as crude coal tar coal, tar lotion, and in refined forms incorporated into ready made creams, lotions and shampoos. A chemical similar to those found in tar may be used on its own--known as Dithranol or Anthralin.

[0010] (ii) UV light: Summer is the best source of ultra-violet light, and many people find psoriasis abates in summer. Treatment in winter can be aided by artificial lamps. Unfortunately, some psoriasis sufferers are sensitive to sun light, and may not be improved with this treatment.

[0011] (iii) Cortisone: External cortisone in various different bases can help psoriasis, but cortisone treatments usually provides relief for 1-2 days at most. There are certain areas such as ears and the backs of hands where tar treatments are not very helpful, and in these areas cortisone applications are usually best. Internal cortisone tablets are best avoided in psoriasis unless other treatments have not been effective. The main problem with cortisone tablets is that they may help initially, but when cortisone treatments are stopped, psoriasis then may flare causing the symptoms to become worse than they were originally.

[0012] (iv) Calcipotriol: Calcipotriol is a synthetic form of vitamin D. Vitamin D has been recognised for many years to address some of the abnormalities present in psoriasis skin, but ingestion of even slightly above the daily recommended amount of Vitamin D can lead to problems with calcium metabolism in the body (possible kidney stones and irregular heart beats). In addition, there is a risk of facial dermatitis if the ointment is used on the face or neck, so application is recommended only for the trunk and limbs, and it is important that the hands are thoroughly washed after application to avoid inadvertent transfer to the skin of the

face.

[0013] (v) PUVA phototherapy: PUVA is the name given to treatment comprising the use of psoralen, which sensitises the skin to the effect of artificial ultraviolet radiation in the A range (UVA), in conjunction with UVA. The combination has a powerful effect on the plaques of psoriasis, slowing down the rapid division of cells recognized to occur in active psoriasis. The dose of UVA exposure is carefully increased as burning of the skin can occur if the treatment is introduced too rapidly. A variation on PUVA phototherapy has been developed. Rather than ingesting psoralen by mouth, a bath containing psoralen is taken for ten minutes immediately before UVA exposure. Sun protection with all forms of PUVA therapy is vital on the days of the treatment.

[0014] (vi) Methotrexate: Methotrexate has been used for treating psoriasis. Methotrexate is also used in higher doses to treat some cancers and leukaemias. Since methotrexate is strong, it is ordered only for people with stubborn psoriasis. Care is taken that ulcers do not develop in the mouth and that blood formation is not affected in early stages after treatment. Methotrexate must not be taken during pregnancy.

[0015] (vii) Tigason: Tigason is a "retinoid" (a synthetic derivative of Vitamin A) and may be used in the management of very severe cases of psoriasis, and with pustular forms of psoriasis. However, women must avoid pregnancy during the treatment with this agent and for one year after completing the course. Dry skin side effects are prominent and cholesterol and fats in the blood must be monitored during the course of treatment.

[0016] (viii) Cyclosporin: Cyclosporin is known to suppress inflammation that occurs during psoriasis. However, during treatment kidney function and blood pressure must be monitored closely.

[0017] None of the above-listed treatments is able to provide a "cure" for psoriasis and, as set out above, each potentially involves side effects such as increased cancer risk, skin damage and kidney damage. Therefore, there is a need

for an effective treatment for psoriasis that is administered relatively simply and has no side effects or less severe side effects than existing available treatments. Thus, there is a need in the art to develop stable, effective RNAi therapeutics for the treatment of psoriasis. The present invention satisfies this need in the art.

### **SUMMARY OF THE INVENTION**

[0018] The present invention provides stable, effective ddRNAi therapeutics and methods for use thereof to control the onset, development, maintenance or progression of psoriasis by altering the level of expression of one or more transcriptionally active genetic regions that are directly or indirectly associated with the onset, development, maintenance or progression of psoriasis.

[0019] The present invention provides a method for treating or preventing psoriasis in an animal together with genetic agents for use therewith, as well as genetically modified cells comprising the genetic agents. The present invention is predicated in part on the use of genetic agents that facilitate gene silencing via RNAi to downregulate or silence one or more transcriptionally active genetic regions directly or indirectly associated with the onset, development, maintenance or progression of psoriasis. Such transcriptionally active regions are also referred to herein as "psoriasis associated genetic targets" or "PATs". ddRNAi-mediated silencing of one or more PATs effects control of any of the onset, development, maintenance or progression of psoriasis and thereby provides a modality to treat, prevent or control psoriasis in a subject.

[0020] Accordingly, one aspect of the present invention contemplates a method for treating or preventing psoriasis in a subject, said method comprising administering to said subject a genetic construct comprising at least one ddRNAi expression cassette which encodes an RNA molecule comprising a nucleotide sequence which is at least 70% identical to at least part of a nucleotide sequence comprising a PAT or a derivative, ortholog or homolog thereof and which delays, represses or otherwise reduces the expression of the PAT in said subject.

[0021] In another aspect, the present invention provides genetically modified cells comprising a ddRNAi expression construct as described herein. Preferably the cell is a mammalian cell, even more preferably the cell is a primate or rodent cell and most preferably the cell is a human or mouse cell. Furthermore, in yet another aspect, the present invention provides a multicellular structure comprising one or more genetically modified cells of the present invention. Multicellular structures include, inter alia, include a tissue, organ or complete organism.

[0022] Other objects and advantages of the present invention will be apparent from the detailed description that follows

### **BRIEF DESCRIPTION OF THE DRAWINGS**

[0023] So that the manner in which the above recited features, advantages and objects of the present invention are attained and can be understood in detail, a more particular description of the invention, briefly summarized above, may be had by reference to the embodiments that are illustrated in the appended drawings. It is to be noted, however, that the appended drawings illustrate only certain embodiments of this invention and are therefore not to be considered limiting of its scope, for the present invention may admit to other equally effective embodiments.

[0024] Figures 1A, 1B and 1C are simplified block diagrams of three embodiments of methods for delivering RNAi agents to treat psoriasis according to the present invention.

[0025] Figures 2A and 2B show two embodiments of single-expression RNAi cassettes, and Figures 2C and 2D show two embodiments of multiple-expression RNAi cassettes.

[0026] Figures 3A and 3B show two embodiments of multiple expression cassettes that code for RNAi agents initially expressed as shRNA precursors, and Figures 3C and 3D show two embodiments of multiple expression cassettes that code for RNAi agents that are not expressed as shRNA precursors.

[0027] Figures 4A and 4B show alternative methods for producing viral particles for delivery of ddRNAi agents to epithelial tissue.

[0028] Figure 5 shows a list of exemplary PAT sequences.

### **DETAILED DESCRIPTION**

[0029] Before the present compositions and methods are described, it is to be understood that this invention is not limited to the particular methodology, products, apparatus and factors described, as such methods, apparatus and formulations may, of course, vary. It is also to be understood that the terminology used herein is for the purpose of describing particular embodiments only, and is not intended to limit the scope of the present invention, which will be limited only by appended claims.

[0030] As used herein, the singular forms "a," "an," and "the" include plural referents unless the context clearly dictates otherwise. Thus, for example, reference to "a factor" refers to one or mixtures of factors, and reference to "the method of production" includes reference to equivalent steps and methods known to those skilled in the art, and so forth.

[0031] Unless defined otherwise, all technical and scientific terms used herein have the same meaning as commonly understood by one of ordinary skill in the art to which this invention belongs. All publications mentioned herein are incorporated herein by reference, without limitation, for the purpose of describing and disclosing devices, formulations and methodologies which are described in the publication and which might be used in connection with the presently described invention.

[0032] In the following description, numerous specific details are set forth to provide a more thorough understanding of the present invention. However, it will be apparent to one of skill in the art that the present invention may be practiced without one or more of these specific details. In other instances, well-known features and procedures well known to those skilled in the art have not been described in order to



avoid obscuring the invention.

[0033] The present invention is directed to innovative, robust genetic compositions and methods to treat psoriasis. The compositions and methods provide stable, lasting inhibition of a target gene.

[0034] Generally, conventional methods of molecular biology, microbiology, recombinant DNA techniques, cell biology, and virology within the skill of the art are employed in the present invention. Such techniques are explained fully in the literature, see, e.g., Maniatis, Fritsch & Sambrook, Molecular Cloning: A Laboratory Manual (1982); DNA Cloning: A Practical Approach, Volumes I and II (D.N. Glover, ed. 1985); Oligonucleotide Synthesis (M.J. Gait, ed. 1984); Nucleic Acid Hybridization (B.D. Hames & S.J. Higgins, eds. (1984)); Animal Cell Culture (R.I. Freshney, ed. 1986); and RNA Viruses: A practical Approach, (Alan, J. Cann, Ed., Oxford University Press, 2000).

[0035] A "vector" is a replicon, such as plasmid, phage, viral construct or cosmid, to which another DNA segment may be attached. Vectors are used to transduce and express the DNA segment in cells. As used herein, the terms "vector", "construct", "ddRNAi expression vector" or "ddRNAi expression construct" may include replicons such as plasmids, phage, viral constructs, cosmids, Bacterial Artificial Chromosomes (BACs), Yeast Artificial Chromosomes (YACs) Human Artificial Chromosomes (HACs) and the like into which one or more ddRNAi expression cassettes may be or are ligated.

[0036] A "promoter" or "promoter sequence" is a DNA regulatory region capable of binding RNA polymerase in a cell and initiating transcription of a polynucleotide or polypeptide coding sequence such as messenger RNA, ribosomal RNAs, small nuclear or nucleolar RNAs or any kind of RNA transcribed by any class of any RNA polymerase.

[0037] A cell has been "transformed", "transduced" or "transfected" by an exogenous or heterologous nucleic acid or vector when such nucleic acid has been introduced inside the cell, for example, as a complex with transfection reagents or

packaged in viral particles. The transforming DNA may or may not be integrated (covalently linked) into the genome of the cell. With respect to eukaryotic cells, a stably transformed cell is one in which the transforming DNA has become integrated into a host cell chromosome or is maintained extra-chromosomally so that the transforming DNA is inherited by daughter cells during cell replication or is a non-replicating, differentiated cell in which a persistent episome is present.

[0038] The term “RNA interference” or “RNAi” refers generally to a process in which a double-stranded RNA molecule changes the expression of a nucleic acid sequence with which the double-stranded or short hairpin RNA molecule shares substantial or total homology. The term or “RNAi agent” refers to an RNA sequence that elicits RNAi; and the term “ddRNAi agent” refers to an RNAi agent that is transcribed from a vector. The terms “short hairpin RNA” or “shRNA” refer to an RNA structure having a duplex region and a loop region. In some embodiments of the present invention, ddRNAi agents are expressed initially as shRNAs. The term “RNAi expression cassette” refers to a cassette according to embodiments of the present invention having at least one [promoter-RNAi agent-terminator] unit. The term “multiple promoter RNAi expression cassette” refers to an RNAi expression cassette comprising two or more [promoter-RNAi agent-terminator] units. The terms “RNAi expression construct” or “RNAi expression vector” refer to vectors containing an RNAi expression cassette.

[0039] “Derivatives” of a gene or nucleotide sequence refers to any isolated nucleic acid molecule that contains significant sequence similarity to the gene or nucleotide sequence or a part thereof. In addition, “derivatives” include such isolated nucleic acids containing modified nucleotides or mimetics of naturally-occurring nucleotides.

[0040] Figures 1A, 1B and 1C are simplified flow charts showing the steps of methods according to three embodiments of the present invention in which an RNAi agent according to the present invention may be used. Method 100 of Figure 1A includes a step 200 in which a ddRNAi expression cassette is constructed. Such a ddRNAi expression cassette most often will include at least one promoter, a ddRNAi

sequence to be expressed, and at least one terminator. Various configurations of such ddRNAi expression cassettes are described in detail *infra*. In step 300, the ddRNAi expression cassette is ligated into viral delivery vector, and at step 400, the ddRNAi viral delivery vector is packaged into viral particles. Finally, at step 500, the viral particles are delivered to target cells, tissues or organs. Figure 1B shows a method 101 where again, at step 200, a ddRNAi expression cassette is constructed. In Figure B, however, the ddRNAi expression cassette is ligated into a non-viral delivery vector at step 600. Then, at step 700, the non-viral ddRNAi delivery vector is delivered to target cells, tissues or organs. Figure 1C shows a method 102 where at step 800, an siRNA agent is constructed for delivery. At step 900, the siRNA is formulated with an appropriate carrier for delivery. Finally, at step 1000, the siRNA agent/carrier is delivered to target cells, tissues, or organs.

[0041] RNAi agents according to the present invention can be generated synthetically or enzymatically by a number of different protocols known to those skilled in the art and purified using standard recombinant DNA techniques as described in, for example, Sambrook et al., Molecular Cloning: A Laboratory Manual, 2nd Ed., Cold Spring Harbor Press, Cold Spring Harbor, NY (1989), and under regulations described in, e.g., United States Dept. of HHS, National Institute of Health (NIH) Guidelines for Recombinant DNA Research.

[0042] RNAi agents may comprise either siRNAs (synthetic RNAs) or DNA-directed RNAs (ddRNAs). siRNAs may be manufactured by methods known in the art such as by typical oligonucleotide synthesis, and often will incorporate chemical modifications to increase half life and/or efficacy of the siRNA agent, and/or to allow for a more robust delivery formulation. Many modifications of oligonucleotides are known in the art. For example, U.S. Pat. No. 6,620,805 discloses an oligonucleotide that is combined with a macrocycle having a net positive charge such as a porphyrin; U.S. Pat. No.6,673,611 discloses various formulas; U.S. Publ. Nos. 2004/0171570, 2004/0171032, and 2004/0171031 disclose oligomers that include a modification comprising a polycyclic sugar surrogate; such as a cyclobutyl nucleoside, cyclopentyl nucleoside, proline nucleoside, cyclohexene nucleoside, hexose nucleoside or a cyclohexane nucleoside; and oligomers that include a

non-phosphorous-containing internucleoside linkage; U.S. Publ. No. 2004/0171579 discloses a modified oligonucleotide where the modification is a 2' substituent group on a sugar moiety that is not H or OH; U.S. Publ. No. 2004/0171030 discloses a modified base for binding to a cytosine, uracil, or thymine base in the opposite strand comprising a boronated C and U or T modified binding base having a boron-containing substituent selected from the group consisting of  $-BH_2CN$ ,  $--BH_3$ , and  $--BH_2COOR$ , wherein R is C1 to C18 alkyl; U.S. Publ. No. 2004/0161844 discloses oligonucleotides having phosphoramidate internucleoside linkages such as a 3'aminophosphoramidate, aminoalkylphosphoramidate, or aminoalkylphosphorothioamidate internucleoside linkage; U.S. Publ. No. 2004/0161844 discloses yet other modified sugar and/or backbone modifications, where in some embodiments, the modification is a peptide nucleic acid, a peptide nucleic acid mimic, a morpholino nucleic acid, hexose sugar with an amide linkage, cyclohexenyl nucleic acid (CeNA), or an acyclic backbone moiety; U.S. Publ. No. 2004/0161777 discloses oligonucleotides with a 3' terminal cap group; U.S. Publ. No. 2004/0147470 discloses oligomeric compounds that include one or more cross-linkages that improve nuclease resistance or modify or enhance the pharmacokinetic and pharmacodynamic properties of the oligomeric compound where such cross-linkages comprise a disulfide, amide, amine, oxime, oxyamine, oxyimine, morpholino, thioether, urea, thiourea, or sulfonamide moiety; U.S. Publ. No. 2004/0147023 discloses a gapmer comprising two terminal RNA segments having nucleotides of a first type and an internal RNA segment having nucleotides of a second type where nucleotides of said first type independently include at least one sugar substituent where the sugar substituent comprises a halogen, amino, trifluoroalkyl, trifluoroalkoxy, azido, aminoxy, alkyl, alkenyl, alkynyl, O-, S-, or N(R\*)-alkyl; O-, S-, or N(R\*)-alkenyl; O-, S- or N(R\*)-alkynyl; O-, S- or N-aryl, O-, S-, or N(R\*)-aralkyl group; where the alkyl, alkenyl, alkynyl, aryl or aralkyl may be a substituted or unsubstituted alkyl, alkenyl, alkynyl, aralkyl; and where, if substituted, the substitution is an alkoxy, thioalkoxy, phthalimido, halogen, amino, keto, carboxyl, nitro, nitroso, cyano, trifluoromethyl, trifluoromethoxy, imidazole, azido, hydrazino, aminoxy, isocyanato, sulfoxide, sulfone, disulfide, silyl, heterocycle, or carbocycle group, or an intercalator, reporter group, conjugate, polyamine, polyamide,

polyalkylene glycol, or a polyether of the formula  $(-O-alkyl)_m$ , where  $m$  is 1 to about 10; and  $R^*$  is hydrogen, or a protecting group; or U.S. Publ. No. 2004/0147022 disclosing an oligonucleotide with a modified sugar and/or backbone modification, such as a 2'-OCH<sub>3</sub> substituent group on a sugar moiety.

[0043] Alternatively, DNA-directed RNAi (ddRNAi) agents may be employed. ddRNAi agents comprise an expression cassette, most often containing at least one promoter, at least one ddRNAi sequence and at least one terminator in a viral or non-viral vector backbone. For example, In one preferred embodiment, the ddRNAi expression cassette comprises a nucleic acid molecule comprising the general structure (I):

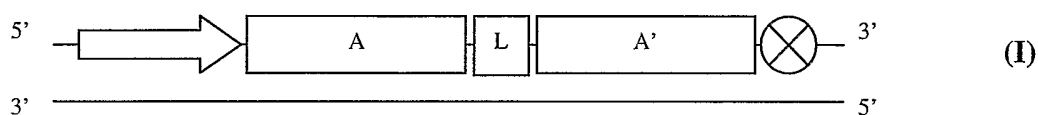

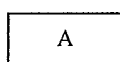

wherein:

 represents a promoter sequence;

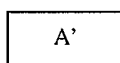
 represents a ddRNAi targeting sequence comprising at least 10 nucleotides, wherein said sequence is at least 70% identical to a PAT sequence or part thereof;

 represents a sequence of 10 to 30 nucleotides wherein at least 10 contiguous nucleotides of  $A'$  comprise a reverse complement of the nucleotide sequence represented by  $A$ ;

 represents a "loop" encoding structure comprising a sequence of 5 to 20 non-self-complementary nucleotides; and

 represents a terminator sequence.

The ddRNAi agent generated by the expression of the ddRNAi expression

cassette represented by general structure (I) comprises a stem-loop structured precursor (shRNA) in which the ends of the double-stranded RNA are connected by a single-stranded, linker RNA. The length of the single-stranded loop portion of the shRNA may be 5 to 20 bp in length, and is preferably 5 to 9 bp in length. Accordingly, in a preferred embodiment, L in general structure (I) comprises 5, 6, 7, 8 or 9 non-self-complementary nucleotides.

[0044] In another embodiment, the ddRNAi expression cassette comprises a nucleic acid molecule of the general structure (II):

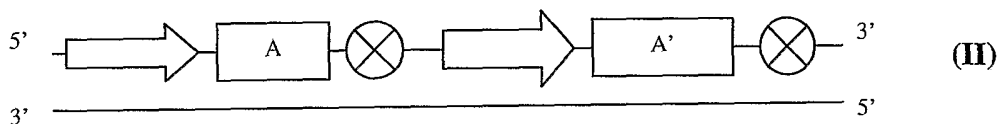

wherein:

 represents a promoter sequence;

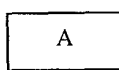
 represents a ddRNAi targeting sequence comprising at least 10 nucleotides, wherein said sequence is at least 70% identical to a PAT sequence or part thereof;

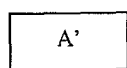
 represents a sequence of 10 to 30 nucleotides wherein at least 10 contiguous nucleotides of A' comprise a reverse complement of the nucleotide sequence represented by A; and

 represents a terminator sequence.

[0045] In yet another embodiment, the ddRNAi expression cassette comprises a nucleic acid molecule of the general structure (III):

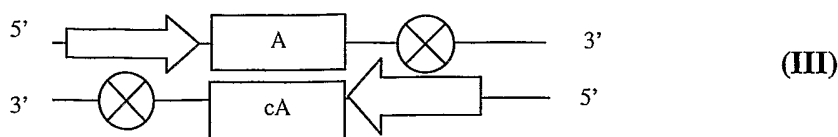

wherein:

 represents a promoter sequence;

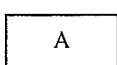
 represents a ddRNAi targeting sequence comprising at least 10 nucleotides, wherein said sequence is at least 70% identical to a PAT sequence or part thereof;

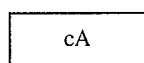
 represents a nucleic acid sequence complementary to A; and

 represents a terminator sequence.

[0046] In yet another preferred embodiment, the ddRNAi expression cassette comprises a nucleic acid molecule of the general structure (IV):

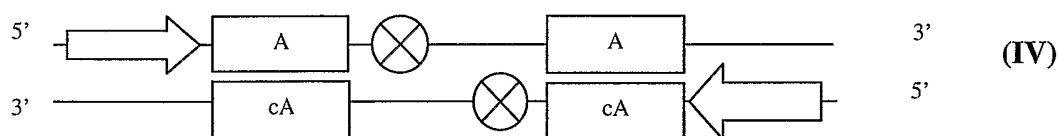

wherein:

 represents a promoter sequence;

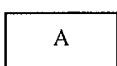
 represents a ddRNAi targeting sequence comprising at least 10 nucleotides, wherein said sequence is at least 70% identical to a PAT sequence or part thereof;

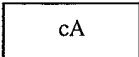
 represents a nucleic acid sequence complementary to A; and

 represents a terminator sequence.

[0047] Although the ddRNAi expression cassettes represented by general structures (I), (II), (III) and (IV) represent preferred embodiments of the invention, the present invention is in no way limited to these particular general structures. As would be evident to one of skill in the art, the above structures may be modified while retaining functionality. For example, the elements of the cassettes may be separated by one or more nucleotide residues. Furthermore, elements which are present on complementary strands, such as the terminator and promoter elements shown in structures (III) and (IV) may overlap or may be discreet. For example, the terminator elements shown in structure (III) may occur within the complementary strand of the promoter element or may be upstream or downstream of this region. Other modifications which would be evident to one of skill in the art and which do not materially effect the functioning of the cassette in encoding a dsRNA structure may also be made and such modified cassettes are within the scope of the present invention.

[0048] Figures 2A through 2D show additional examples of ddRNAi expression cassettes. Figures 2A and 2B are simplified schematics of single-promoter RNAi expression cassettes according to embodiments of the present invention. Figure 2A shows an embodiment of a single RNAi expression cassette (10) comprising one promoter/RNAi/terminator component (shown at 20), where the ddRNAi agent is expressed initially as a short hairpin (shRNA). Figure 2B shows an embodiment of a single RNAi expression cassette (10) with one promoter/RNAi/terminator component (shown at 20), where the sense and antisense components of the ddRNAi agent are expressed separately from different promoters.

[0049] Figures 2C and 2D are simplified schematics of multiple-promoter RNAi expression cassettes according to embodiments of the present invention. Figure 2C shows an embodiment of a multiple-promoter RNAi expression cassette (10) comprising three promoter/RNAi/terminator components (shown at 20), and Figure



2D shows an embodiment of a multiple-promoter expression cassette (10) with five promoter/RNAi/terminator components (shown at 20). P1, P2, P3, P4 and P5 represent promoter elements. RNAi1, RNAi2, RNAi3, RNAi4 and RNAi5 represent sequences for five different ddRNAi agents. T1, T2, T3, T4, and T5 represent termination elements. The multiple-promoter RNAi expression cassettes according to the present invention may contain two or more promoter/RNAi/terminator components where the number of promoter/RNAi/terminator components included in any multiple-promoter RNAi expression cassette is limited by, e.g., packaging size of the delivery system chosen (for example, some viruses, such as AAV, have relatively strict size limitations); cell toxicity, and maximum effectiveness (i.e. when, for example, expression of four ddRNAi agents is as effective therapeutically as the expression of ten ddRNAi agents).

[0050] When employing a multiple promoter RNAi expression cassette, the two or more ddRNAi agents in the promoter/RNAi/terminator components comprising a cassette all have different sequences; that is RNAi1, RNAi2, RNAi3, RNAi4 and RNAi5 are all different from one another. However, the promoter elements in any cassette may be the same (that is, e.g., the sequence of two or more of P1, P2, P3, P4 and P5 may be the same); all the promoters within any cassette may be different from one another; or there may be a combination of promoter elements represented only once and promoter elements represented two times or more within any cassette. Similarly, the termination elements in any cassette may be the same (that is, e.g., the sequence of two or more of T1, T2, T3, T4 and T5 may be the same, such as contiguous stretches of 4 or more T residues); all the termination elements within any cassette may be different from one another; or there may be a combination of termination elements represented only once and termination elements represented two times or more within any cassette. Preferably, the promoter elements and termination elements in each promoter/RNAi/terminator component comprising any cassette are all different to decrease the likelihood of DNA recombination events between components and/or cassettes. Further, in a preferred embodiment, the promoter element and termination element used in each promoter/RNAi/terminator component are matched to each other; that is, the

promoter and terminator elements are taken from the same gene in which they occur naturally.

[0051] Figures 3A and 3B show multiple-promoter RNAi expression constructs comprising alternative embodiments of multiple-promoter RNAi expression cassettes that express short shRNAs. shRNAs are short duplexes where the sense and antisense strands are linked by a hairpin loop. Once expressed, shRNAs are processed into RNAi agents. A, B and C represent three different promoter elements, and the arrows indicate the direction of transcription. Term1, Term2, and Term3 represent three different termination sequences, and shRNA-1, shRNA-2 and shRNA-3 represent three different shRNA sequences. The multiple-promoter RNAi expression cassettes in both embodiments extend from the box marked A to the Term3. Figure 3A shows each of the three promoter/RNAi/terminator components (20) in the same orientation within the cassette, while Figure 3B shows the promoter/RNAi/terminator components for shRNA-1 and shRNA-3 in one orientation, and the promoter/RNAi/terminator component for sh-RNA2 in the opposite orientation (i.e., transcription takes place on both strands of the cassette). Other variations may be used as well.

[0052] Figures 3C and 3D show multiple-promoter RNAi expression constructs comprising alternative embodiments of multiple-promoter RNAi expression cassettes that express RNAi agents without a hairpin loop. In both figures, P1, P2, P3, P4, P5 and P6 represent promoter elements (with arrows indicating the direction of transcription); and T1, T2, T3, T4, T5, and T6 represent termination elements. Also in both figures, RNAi1 sense and RNAi1 antisense (a/s) are complements, RNAi2 sense and RNAi2 a/s are complements, and RNAi3 sense and RNAi3 a/s are complements.

[0053] In the embodiment shown in Figure 3C, all three RNAi sense sequences are transcribed from one strand (via P1, P2 and P3), while the three RNAi a/s sequences are transcribed from the complementary strand (via P4, P5, P6). In this particular embodiment, the termination element of RNAi1 a/s (T4) falls between promoter P1 and the RNAi 1 sense sequence; while the termination element of

RNAi1 sense (T1) falls between the RNAi 1 a/s sequence and its promoter, P4. This motif is repeated such that if the top strand shown in Figure 3C is designated the (+) strand and the bottom strand is designated the (-) strand, the elements encountered moving from left to right would be P1(+), T4(-), RNAi1 (sense and a/s), T1(+), P4(-), P2(+), T5(-), RNAi2 (sense and a/s), T2(+), P5(-), P3(+), T6(-), RNAi3 (sense and a/s), T3(+), and P6(-).

[0054] In an alternative embodiment shown in Figure 3D, all RNAi sense and antisense sequences are transcribed from the same strand. One skilled in the art appreciates that any of the embodiments of the multiple-promoter RNAi expression cassettes shown in Figures 3A through 3D may be used for certain applications, as well as combinations or variations thereof.

[0055] In some embodiments, promoters of variable strength may be employed. For example, use of two or more strong promoters (such as a Pol III-type promoter) may tax the cell, by, e.g., depleting the pool of available nucleotides or other cellular components needed for transcription. In addition or alternatively, use of several strong promoters may cause a toxic level of expression of RNAi agents in the cell. Thus, in some embodiments one or more of the promoters in the multiple-promoter RNAi expression cassette may be weaker than other promoters in the cassette, or all promoters in the cassette may express RNAi agents at less than a maximum rate. Promoters also may or may not be modified using molecular techniques, or otherwise, e.g., through regulation elements, to attain weaker levels of transcription.

[0056] Promoters useful in some embodiments of the present invention may be tissue-specific or cell-specific. The term "tissue specific" as it applies to a promoter refers to a promoter that is capable of directing selective expression of a nucleotide sequence of interest to a specific type of tissue (e.g., epithelial tissue) in the relative absence of expression of the same nucleotide sequence of interest in a different type of tissue (e.g., muscle). The term "cell-specific" as applied to a promoter refers to a promoter which is capable of directing selective expression of a nucleotide sequence of interest in a specific type of cell in the relative absence of expression of the same nucleotide sequence of interest in a different type of cell within the same

tissue (see, e.g., Higashibata, et al., J. Bone Miner. Res. Jan 19(1):78-88 (2004); Hoggatt, et al., Circ. Res., Dec. 91(12):1151-59 (2002); Sohal, et al., Circ. Res. Jul 89(1):20-25 (2001); and Zhang, et al., Genome Res. Jan 14(1):79-89 (2004)). The term "cell-specific" when applied to a promoter also means a promoter capable of promoting selective expression of a nucleotide sequence of interest in a region within a single tissue. Alternatively, promoters may be constitutive or regulatable. Additionally, promoters may be modified so as to possess different specificities.

[0057] The term "constitutive" when made in reference to a promoter means that the promoter is capable of directing transcription of an operably linked nucleic acid sequence in the absence of a specific stimulus (e.g., heat shock, chemicals, light, etc.). Typically, constitutive promoters are capable of directing expression of a coding sequence in substantially any cell and any tissue. The promoters used to transcribe the RNAi agents preferably are constitutive promoters, such as the promoters for ubiquitin, CMV,  $\beta$ -actin, histone H4, EF-1 $\alpha$  or pgk genes controlled by RNA polymerase II, or promoter elements controlled by RNA polymerase I. In other embodiments, a Pol II promoter such as CMV, SV40, U1,  $\beta$ -actin or a hybrid Pol II promoter is employed. In other embodiments, promoter elements controlled by RNA polymerase III are used, such as the U6 promoters (U6-1, U6-8, U6-9, e.g.), H1 promoter, 7SL promoter, the human Y promoters (hY1, hY3, hY4 (see Maraia, et al., Nucleic Acids Res 22(15):3045-52 (1994)) and hY5 (see Maraia, et al., Nucleic Acids Res 24(18):3552-59 (1994)), the human MRP-7-2 promoter, Adenovirus VA1 promoter, human tRNA promoters, the 5s ribosomal RNA promoters, as well as functional hybrids and combinations of any of these promoters.

[0058] Alternatively in some embodiments it may be optimal to select promoters that allow for inducible expression of the RNAi agent. A number of systems for inducible expression using such promoters are known in the art, including but not limited to the tetracycline responsive system and the *lac* operator-repressor system (see WO 03/022052 A1; and US 2002/0162126 A1), the ecdyson regulated system, or promoters regulated by glucocorticoids, progestins, estrogen, RU-486, steroids, thyroid hormones, cyclic AMP, cytokines, the calciferol family of regulators, or the

metallothionein promoter (regulated by inorganic metals).

[0059] One or more enhancers also may be present in the viral multiple-promoter RNAi expression construct to increase expression of the gene of interest. Enhancers appropriate for use in embodiments of the present invention include the Apo E HCR enhancer, the CMV enhancer that has been described recently (see, Xia et al, Nucleic Acids Res 31-17 (2003)), and other enhancers known to those skilled in the art.

[0060] The RNAi sequences encoded by the RNAi expression cassettes of the present invention result in the expression of small interfering RNAs that are short, double-stranded RNAs that are not toxic in normal mammalian cells. There is no particular limitation in the length of the ddRNAi agents of the present invention as long as they do not show cellular toxicity. RNAis can be, for example, 15 to 49 bp in length, preferably 15 to 35 bp in length, and are more preferably 19 to 29 bp in length. The double-stranded RNA portions of RNAis may be completely homologous, or may contain non-paired portions due to sequence mismatch (the corresponding nucleotides on each strand are not complementary), bulge (lack of a corresponding complementary nucleotide on one strand), and the like. Such non-paired portions can be tolerated to the extent that they do not significantly interfere with RNAi duplex formation or efficacy.

[0061] The termini of a ddRNAi agent according to the present invention may be blunt or cohesive (overhanging) as long as the ddRNAi agent effectively silences the target gene. The cohesive (overhanging) end structure is not limited only to a 3' overhang, but a 5' overhanging structure may be included as long as the resulting ddRNAi agent is capable of inducing the RNAi effect. In addition, the number of overhanging nucleotides may be any number as long as the resulting ddRNAi agent is capable of inducing the RNAi effect. For example, if present, the overhang may consist of 1 to 8 nucleotides, preferably it consists of 2 to 4 nucleotides.

[0062] The ddRNAi agent utilized in the present invention may have a stem-loop structured precursor (shRNA) in which the ends of the double-stranded RNA are

connected by a single-stranded, linker RNA. The length of the single-stranded loop portion of the shRNA may be 5 to 20 bp in length, and is preferably 5 to 9 bp in length.

[0063] The nucleic acid sequences that are targets for the RNAi expression cassettes of the present invention include genes that are involved in psoriasis in general, including but not limited to epithelial hyperproliferation. The sequences for the RNAi agent or agents are selected based upon the genetic sequence of the target gene sequence(s); and preferably are based on regions of the target gene sequences that are conserved. Methods of alignment of sequences for comparison and RNAi sequence selection are well known in the art. The determination of percent identity between two or more sequences can be accomplished using a mathematical algorithm. Preferred, non-limiting examples of such mathematical algorithms are the algorithm of Myers and Miller (1988); the search-for-similarity-method of Pearson and Lipman (1988); and that of Karlin and Altschul (1993). Preferably, computer implementations of these mathematical algorithms are utilized. Such implementations include, but are not limited to: CLUSTAL in the PC/Gene program (available from Intelligenetics, Mountain View, Calif.); the ALIGN program (Version 2.0), GAP, BESTFIT, BLAST, FASTA, Megalign (using Jotun Hein, Martinez, Needleman-Wunsch algorithms), DNASTar Lasergene (see [www.dnastar.com](http://www.dnastar.com)) and TFASTA in the Wisconsin Genetics Software Package, Version 8 (available from Genetics Computer Group (GCG), 575 Science Drive, Madison, Wis., USA). Alignments using these programs can be performed using the default parameters or parameters selected by the operator. The CLUSTAL program is well described by Higgins. The ALIGN program is based on the algorithm of Myers and Miller; and the BLAST programs are based on the algorithm of Karlin and Altschul. Software for performing BLAST analyses is publicly available through the National Center for Biotechnology Information (<http://www.ncbi.nlm.nih.gov/>).

[0064] For sequence comparison, typically one sequence acts as a reference sequence to which test sequences are compared. When using a sequence comparison algorithm, test and reference sequences are input into a computer, subsequence coordinates are designated if necessary, and sequence

algorithm program parameters are designated. The sequence comparison algorithm then calculates the percent sequence identity for the test sequence(s) relative to the reference sequence, based on the designated program parameters.

[0065] Typically, inhibition of target sequences by RNAi requires a high degree of sequence homology between the target sequence and the sense strand of the RNAi molecules. In some embodiments, such homology is higher than about 70%, and may be higher than about 75%. Preferably, homology is higher than about 80%, and is higher than 85% or even 90%. More preferably, sequence homology between the target sequence and the sense strand of the RNAi is higher than about 90%, 91%, 92%, 93%, 94%, 95%, 96%, 97%, 98% or 99%.

[0066] In addition to selecting the RNAi sequences based on conserved regions of a target gene, selection of the RNAi sequences may be based on other factors. Despite a number of attempts to devise selection criteria for identifying sequences that will be effective in RNAi based on features of the desired target sequence (e.g., percent GC content, position from the translation start codon, or sequence similarities based on an *in silico* sequence database search for homologs of the proposed RNAi, thermodynamic pairing criteria), it is presently not possible to predict with much degree of confidence which of the myriad possible candidate RNAi sequences corresponding to a target gene, in fact, elicit an optimal RNA silencing response. Instead, individual specific candidate RNAi polynucleotide sequences typically are generated and tested to determine whether interference with expression of a desired target can be elicited.

[0067] As stated, the ddRNAi agent coding regions of RNAi expression cassette are operatively linked to terminator elements. In one embodiment, the terminators comprise stretches of four or more thymidine residues. In embodiments where multiple promoter cassettes are used, the terminator elements used all may be different and are matched to the promoter elements from the gene from which the terminator is derived. Such terminators include the SV40 poly A, the Ad VA1 gene, the 5S ribosomal RNA gene, and the terminators for human t-RNAs. In addition, promoters and terminators may be mixed and matched, as is commonly done with

RNA pol II promoters and terminators.

[0068] In addition, the RNAi expression cassettes may be configured where multiple cloning sites and/or unique restriction sites are located strategically, such that the promoter, ddRNAi agents and terminator elements are easily removed or replaced. The RNAi expression cassettes may be assembled from smaller oligonucleotide components using strategically located restriction sites and/or complementary sticky ends. The base vector for one approach according to embodiments of the present invention consists of plasmids with a multilinker in which all sites are unique (though this is not an absolute requirement). Sequentially, each promoter is inserted between its designated unique sites resulting in a base cassette with one or more promoters, all of which can have variable orientation. Sequentially, again, annealed primer pairs are inserted into the unique sites downstream of each of the individual promoters, resulting in a single-, double- or multiple-expression cassette construct. The insert can be moved into, e.g. an AAV backbone using two unique enzyme sites (the same or different ones) that flank the single-, double- or multiple-expression cassette insert.

[0069] When using a ddRNAi agent, the RNAi expression cassette is ligated into a delivery vector. The constructs into which the RNAi expression cassette is inserted and used for high efficiency transduction and expression of the ddRNAi agents in various cell types may be derived from viruses and are compatible with viral delivery; alternatively, non-viral delivery method may be used. Generation of the construct can be accomplished using any suitable genetic engineering techniques well known in the art, including without limitation, the standard techniques of PCR, oligonucleotide synthesis, restriction endonuclease digestion, ligation, transformation, plasmid purification, and DNA sequencing. If the construct is a viral construct, the construct preferably comprises, for example, sequences necessary to package the RNAi expression construct into viral particles and/or sequences that allow integration of the RNAi expression construct into the target cell genome. The viral construct also may contain genes that allow for replication and propagation of virus, though in other embodiments such genes will be supplied *in trans*. Additionally, the viral construct may contain genes or genetic



sequences from the genome of any known organism incorporated in native form or modified. For example, a preferred viral construct may comprise sequences useful for replication of the construct in bacteria.

[0070] The construct also may contain additional genetic elements. The types of elements that may be included in the construct are not limited in any way and may be chosen by one with skill in the art. For example, additional genetic elements may include a reporter gene, such as one or more genes for a fluorescent marker protein such as GFP or RFP; an easily assayed enzyme such as beta-galactosidase, luciferase, beta-glucuronidase, chloramphenicol acetyl transferase or secreted embryonic alkaline phosphatase; or proteins for which immunoassays are readily available such as hormones or cytokines. Other genetic elements that may find use in embodiments of the present invention include those coding for proteins which confer a selective growth advantage on cells such as adenosine deaminase, aminoglycoside phosphotransferase, dihydrofolate reductase, hygromycin-B-phosphotransferase, drug resistance, or those genes coding for proteins that provide a biosynthetic capability missing from an auxotroph. If a reporter gene is included along with the RNAi expression cassette, an internal ribosomal entry site (IRES) sequence can be included. Preferably, the additional genetic elements are operably linked with and controlled by an independent promoter/enhancer. In addition a suitable origin of replication for propagation of the construct in bacteria may be employed. The sequence of the origin of replication generally is separated from the ddRNAi agent and other genetic sequences that are to be expressed in the epithelial tissue. Such origins of replication are known in the art and include the pUC, ColE1, 2-micron or SV40 origins of replication.

[0071] A viral delivery system based on any appropriate virus may be used to deliver the RNAi expression constructs of the present invention. In addition, hybrid viral systems may be of use. The choice of viral delivery system will depend on various parameters, such as efficiency of delivery into epithelial tissue, transduction efficiency of the system, pathogenicity, immunological and toxicity concerns, and the like. It is clear that there is no single viral system that is suitable for all applications. When selecting a viral delivery system to use in the present invention, it is

important to choose a system where RNAi expression construct-containing viral particles are preferably: 1) reproducibly and stably propagated; 2) able to be purified to high titers; and 3) able to mediate targeted delivery (delivery of the multiple-promoter RNAi expression construct to the epithelial tissue without widespread dissemination).

[0072] In general, the five most commonly used classes of viral systems used in gene therapy can be categorized into two groups according to whether their genomes integrate into host cellular chromatin (oncoretroviruses and lentiviruses) or persist in the cell nucleus predominantly as extrachromosomal episomes (adeno-associated virus, adenoviruses and herpesviruses).

[0073] For example, in one embodiment of the present invention, viruses from the Parvoviridae family are utilized. The Parvoviridae is a family of small single-stranded, non-enveloped DNA viruses with genomes approximately 5000 nucleotides long. Included among the family members is adeno-associated virus (AAV), a dependent parvovirus that by definition requires co-infection with another virus (typically an adenovirus or herpesvirus) to initiate and sustain a productive infectious cycle. In the absence of such a helper virus, AAV is still competent to infect or transduce a target cell by receptor-mediated binding and internalization, penetrating the nucleus in both non-dividing and dividing cells.

[0074] Once in the nucleus, the virus uncoats and the transgene is expressed from a number of different forms—the most persistent of which are circular monomers. AAV will integrate into the genome of 1-5% of cells that are stably transduced (Nakai, et al., *J. Virol.* 76:11343-349 (2002)). Expression of the transgene can be exceptionally stable and in one study with AAV delivery of Factor IX, a dog model continues to express therapeutic levels of the protein 4.5 years after a single direct infusion with the virus. Because progeny virus is not produced from AAV infection in the absence of helper virus, the extent of transduction is restricted only to the initial cells that are infected with the virus. It is this feature that makes AAV a preferred gene therapy vector for the present invention. Furthermore, unlike retrovirus, adenovirus, and herpes simplex virus, AAV appears to lack human

pathogenicity and toxicity (Kay, et al., Nature. 424: 251 (2003) and Thomas, et al., Nature Reviews, Genetics 4:346-58 (2003)).

[0075] Typically, the genome of AAV contains only two genes. The “rep” gene codes for at least four separate proteins utilized in DNA replication. The “cap” gene product is spliced differentially to generate the three proteins that comprise the capsid of the virus. When packaging the genome into nascent virus, only the Inverted Terminal Repeats (ITRs) are obligate sequences; rep and cap can be deleted from the genome and be replaced with heterologous sequences of choice. However, in order produce the proteins needed to replicate and package the AAV-based heterologous construct into nascent virion, the rep and cap proteins must be provided in *trans*. The helper functions normally provided by co-infection with the helper virus, such as adenovirus or herpesvirus mentioned above, also can be provided in *trans* in the form of one or more DNA expression plasmids. Since the genome normally encodes only two genes it is not surprising that, as a delivery vehicle, AAV is limited by a packaging capacity of 4.5 single stranded kilobases (kb). However, although this size restriction may limit the genes that can be delivered for replacement gene therapies, it does not adversely affect the packaging and expression of shorter sequences such as RNAi.

[0076] The utility of AAV for RNAi applications was demonstrated in experiments where AAV was used to deliver shRNA *in vitro* to inhibit p53 and Caspase 8 expression (Tomar et al., Oncogene. 22: 5712-15 (2003)). Following cloning of the appropriate sequences into a gutted AAV-2 vector, infectious AAV virions were generated in HEK293 cells and used to infect HeLa S3 cells. A dose-dependent decrease of endogenous Caspase 8 and p53 levels was demonstrated. Boden et al. also used AAV to deliver shRNA *in vitro* to inhibit HIV replication in tissue culture systems (Boden, et al., J. Virol. 77(21): 115231-35 (2003)) as assessed by p24 production in the spent media.

[0077] However, technical hurdles must be addressed when using AAV as a vehicle for RNAi expression constructs. For example, various percentages of the human population may possess neutralizing antibodies against certain AAV

serotypes. However, since there are several AAV serotypes, some of which the percentage of individuals harboring neutralizing antibodies is vastly reduced, other serotypes can be used or pseudo-typing may be employed. There are at least eight different serotypes that have been characterized, with dozens of others, which have been isolated but have been less well described. Another limitation is that as a result of a possible immune response to AAV, AAV-based therapy may only be administered once; however, use of alternate, non-human derived serotypes may allow for repeat administrations. Administration route, serotype, and composition of the delivered genome all influence tissue specificity.

[0078] Another limitation in using unmodified AAV systems with the RNAi expression constructs is that transduction can be inefficient. Stable transduction *in vivo* may be limited to 5-10% of cells. However, different methods are known in the art to boost stable transduction levels. One approach is utilizing pseudotyping, where AAV-2 genomes are packaged using cap proteins derived from other serotypes. For example, by substituting the AAV-5 cap gene for its AAV-2 counterpart, Mingozzi et al. increased stable transduction to approximately 15% of hepatocytes (Mingozzi, et al., J. Virol. 76(20): 10497-502 (2002)). Thomas et al., transduced over 30% of mouse hepatocytes *in vivo* using the AAV8 capsid gene (Thomas, et al., J. Virol. in press). Grimm et al. (Blood. 2003-02-0495) exhaustively pseudotyped AAV-2 with AAV-1, AAV-3B, AAV-4, AAV-5, and AAV-6 for tissue culture studies. The highest levels of transgene expression were induced by virion which had been pseudotyped with AAV-6; producing nearly 2000% higher transgene expression than AAV-2. Thus, the present invention contemplates use of a pseudotyped AAV virus to achieve high transduction levels, with a corresponding increase in the expression of the RNAi multiple-promoter expression constructs.

[0079] Another viral delivery system useful with the RNAi expression constructs of the present invention is a system based on viruses from the family Retroviridae. Retroviruses comprise single-stranded RNA animal viruses that are characterized by two unique features. First, the genome of a retrovirus is diploid, consisting of two copies of the RNA. Second, this RNA is transcribed by the virion-associated enzyme reverse transcriptase into double-stranded DNA. This double-stranded

DNA or provirus can then integrate into the host genome and be passed from parent cell to progeny cells as a stably-integrated component of the host genome.

[0080] In some embodiments, lentiviruses are the preferred members of the retrovirus family for use in the present invention. Lentivirus vectors are often pseudotyped with vesicular stomatitis virus glycoprotein (VSV-G), and have been derived from the human immunodeficiency virus (HIV), the etiologic agent of the human acquired immunodeficiency syndrome (AIDS); visna-maedi, which causes encephalitis (visna) or pneumonia in sheep; equine infectious anemia virus (EIAV), which causes autoimmune hemolytic anemia and encephalopathy in horses; feline immunodeficiency virus (FIV), which causes immune deficiency in cats; bovine immunodeficiency virus (BIV) which causes lymphadenopathy and lymphocytosis in cattle; and simian immunodeficiency virus (SIV), which causes immune deficiency and encephalopathy in non-human primates. Vectors that are based on HIV generally retain <5% of the parental genome, and <25% of the genome is incorporated into packaging constructs, which minimizes the possibility of the generation of reverting replication-competent HIV. Biosafety has been further increased by the development of self-inactivating vectors that contain deletions of the regulatory elements in the downstream long-terminal-repeat sequence, eliminating transcription of the packaging signal that is required for vector mobilization.

[0081] Reverse transcription of the retroviral RNA genome occurs in the cytoplasm. Unlike C-type retroviruses, the lentiviral cDNA complexed with other viral factors—known as the pre-initiation complex—is able to translocate across the nuclear membrane and transduce non-dividing cells. A structural feature of the viral cDNA—a DNA flap—seems to contribute to efficient nuclear import. This flap is dependent on the integrity of a central polypurine tract (cPPT) that is located in the viral polymerase gene, so most lentiviral-derived vectors retain this sequence. Lentiviruses have broad tropism, low inflammatory potential, and result in an integrated vector. The main limitations are that integration might induce oncogenesis in some applications. The main advantage to the use of lentiviral

vectors is that gene transfer is persistent in most tissues or cell types.

[0082] A lentiviral-based construct used to express the ddRNAi agents preferably comprises sequences from the 5' and 3' LTRs of a lentivirus. More preferably the viral construct comprises an inactivated or self-inactivating 3' LTR from a lentivirus. The 3' LTR may be made self-inactivating by any method known in the art. In a preferred embodiment, the U3 element of the 3' LTR contains a deletion of its enhancer sequence, preferably the TATA box, Sp1 and NF-kappa B sites. As a result of the self-inactivating 3' LTR, the provirus that is integrated into the host cell genome will comprise an inactivated 5' LTR. The LTR sequences may be LTR sequences from any lentivirus from any species. The lentiviral-based construct also may incorporate sequences for MMLV or MSCV, RSV or mammalian genes. In addition, the U3 sequence from the lentiviral 5' LTR may be replaced with a promoter sequence in the viral construct. This may increase the titer of virus recovered from the packaging cell line. An enhancer sequence may also be included.

[0083] Other viral or non-viral systems known to those skilled in the art may be used to deliver the RNAi expression cassettes of the present invention to epithelial tissue, including but not limited to gene-deleted adenovirus-transposon vectors that stably maintain virus-encoded transgenes *in vivo* through integration into host cells (see Yant, et al., Nature Biotech. 20:999-1004 (2002)); systems derived from Sindbis virus or Semliki forest virus (see Perri, et al, J. Virol. 74(20):9802-07 (2002)); systems derived from Newcastle disease virus or Sendai virus; or mini-circle DNA vectors devoid of bacterial DNA sequences (see Chen, et al., Molecular Therapy. 8(3):495-500 (2003)).

[0084] In addition, hybrid viral systems may be used to combine useful properties of two or more viral systems. For example, the site-specific integration machinery of wild-type AAV may be coupled with the efficient internalization and nuclear targeting properties of adenovirus. AAV in the presence of adenovirus or herpesvirus undergoes a productive replication cycle; however, in the absence of helper functions, the AAV genome integrates into a specific site on chromosome 19.

Integration of the AAV genome requires expression of the AAV rep protein. As conventional rAAV vectors are deleted for all viral genes including rep, they are not able to specifically integrate into chromosome 19. However, this feature may be exploited in an appropriate hybrid system. In addition, non-viral genetic elements may be used to achieve desired properties in a viral delivery system, such as genetic elements that allow for site-specific recombination.

[0085] In step 400 of Figure 1A, the RNAi expression construct is packaged into viral particles. Any method known in the art may be used to produce infectious viral particles whose genome comprises a copy of the viral RNAi expression construct. Figures 4A and 4B show alternative methods for packaging the RNAi expression constructs of the present invention into viral particles for delivery. The method in Figure 4A utilizes packaging cells that stably express in *trans* the viral proteins that are required for the incorporation of the viral RNAi expression construct into viral particles, as well as other sequences necessary or preferred for a particular viral delivery system (for example, sequences needed for replication, structural proteins and viral assembly) and either viral-derived or artificial ligands for tissue entry. In Figure 4A, a RNAi expression cassette is ligated to a viral delivery vector (step 300), and the resulting viral RNAi expression construct is used to transfect packaging cells (step 410). The packaging cells then replicate viral sequences, express viral proteins and package the viral RNAi expression constructs into infectious viral particles (step 420). The packaging cell line may be any cell line that is capable of expressing viral proteins, including but not limited to 293, HeLa, A549, PerC6, D17, MDCK, BHK, bing cherry, phoenix, Cf2Th, or any other line known to or developed by those skilled in the art. One packaging cell line is described, for example, in U.S. Pat. No. 6,218,181.

[0086] Alternatively, a cell line that does not stably express necessary viral proteins may be co-transfected with two or more constructs to achieve efficient production of functional particles. One of the constructs comprises the viral RNAi expression construct, and the other plasmid(s) comprises nucleic acids encoding the proteins necessary to allow the cells to produce functional virus (replication and packaging construct) as well as other helper functions. The method shown

in Figure 4B utilizes cells for packaging that do not stably express viral replication and packaging genes. In this case, the RNAi expression construct is ligated to the viral delivery vector (step 300) and then co-transfected with one or more vectors that express the viral sequences necessary for replication and production of infectious viral particles (step 470). The cells replicate viral sequences, express viral proteins and package the viral RNAi expression constructs into infectious viral particles (step 420).

[0087] The packaging cell line or replication and packaging construct may not express envelope gene products. In these embodiments, the gene encoding the envelope gene can be provided on a separate construct that is co-transfected with the viral RNAi expression construct. As the envelope protein is responsible, in part, for the host range of the viral particles, the viruses may be pseudotyped. As described *supra*, a "pseudotyped" virus is a viral particle having an envelope protein that is from a virus other than the virus from which the genome is derived. One with skill in the art can choose an appropriate pseudotype for the viral delivery system used and cell to be targeted. In addition to conferring a specific host range, a chosen pseudotype may permit the virus to be concentrated to a very high titer. Viruses alternatively can be pseudotyped with ecotropic envelope proteins that limit infection to a specific species (e.g., ecotropic envelopes allow infection of, e.g., murine cells only, where amphotropic envelopes allow infection of, e.g., both human and murine cells.) In addition, genetically-modified ligands can be used for cell-specific targeting, such as the asialoglycoprotein for hepatocytes, or transferrin for receptor-mediated binding.

[0088] After production in a packaging cell line, the viral particles containing the RNAi expression cassettes are purified and quantified (titered). Purification strategies include density gradient centrifugation, or, preferably, column chromatographic methods.

[0089] Multiple-promoter RNAi expression cassettes used in certain embodiments of the present invention are particularly useful in treating psoriasis because RNAi agents against multiple genes involved in psoriasis can be targeted



simultaneously. For example, one or more genes that regulate blood clotting and/or epithelial hyperproliferation can be repressed at the same time.

[0090] A variety of techniques are available and well known for delivery of nucleic acids into cells, for example liposome- or micelle-mediated transfection or transformation, transformation of cells with attenuated virus particles or bacterial cells, cell mating, transformation or transfection procedures known to those skilled in the art or microinjection. The RNAi agents, whether siRNAs or ddRNAs, are formulated with an appropriate carrier, which may then be associated with a delivery vehicle such as a matrix such as a compress or bandage, ultimately forming a therapeutic device. The delivery vehicle may be the carrier itself that is a flowable liquid, lotion or gel that is applied to the skin, or a synthetic or naturally-occurring matrix such as a compress or bandage that is applied to the skin. Various chemical formulations for carrier/coatings, and matrices are presented in detail below.

[0091] One delivery vehicle appropriate for use in the present invention is a matrix such as a compress or bandage. In general, a matrix is a scaffold comprising synthetic, semi-synthetic or naturally-occurring compounds that can be used as a delivery vehicle to deliver the RNAi agent to a site that is to be treated. The matrix can be coated with a coating or carrier comprising the RNAi agent, or the RNAi agent can be incorporated directly into the matrix compound, in which case the matrix acts as both the carrier and the scaffold.

[0092] RNAi Agents

[0093] Any RNAi agent that is capable of retarding or arresting the formation of psoriasis is appropriate for incorporation into the coating or carrier, and ultimately the therapeutic device of the present invention. Psoriasis is a chronic skin disease marked by periodic flare-ups of sharply defined red patches covered by a silvery, flaky surface. The primary activity leading to psoriasis occurs in the epidermis, specifically, the top five layers of the skin.

[0094] The process starts in the basal layer, where keratinocytes are produced. Keratinocytes, in turn, manufacture keratin, a protein that forms part of hair, nails

and skin. In normal cell growth, keratinocytes mature and migrate from the basal layer to the surface and are shed unobtrusively. Typically this process takes approximately one month. However, in psoriatic skin, the keratinocytes proliferate very rapidly and travel from the basal layer to the surface in approximately four days. The skin cannot shed these cells quickly enough so they accumulate in thick, dry patches, or plaques. Silvery, flaky areas of dead skin are shed from the surface of these plaques. The underlying area in the dermis is, in turn, red and inflamed due to increased blood supply to the abnormally multiplying keratinocytes. Increasingly, it is believed that these destructive changes originate from genetic abnormalities in the immune system that are triggered by environmental factors.

[0095] A number of psoriasis variants exist. Some can occur independently or at the same time as other variants, or one may follow another. The most common psoriasis variant is called plaque psoriasis. "Psoriatic arthritis" is an important disorder that includes both psoriasis and arthritis. Psoriatic arthritis should be understood to be encompassed by the term "psoriasis" as used herein.

[0096] Plaque psoriasis patches may be defined as follows: (i) the patches start off in small areas; (ii) they gradually enlarge and develop thick, dry plaque--if the plaque is scratched or scraped, bleeding spots the size of pinheads appear underneath (known as the Auspitz sign); (iii) some patches may become ring shaped (annular) with a clear center and scaly raised borders that may be wavy and snake-like; (iv) patches usually appear symmetrically, that is, in the same areas on opposite sides of the body; and (v) eventually separate patches may join together to form larger areas as the disorder develops. In some cases, the patches can become very large and cover wide areas of the back or chest (known as geographic plaques because they resemble maps).

[0097] Plaque psoriasis most often occurs on the elbows, knees, and the lower back. Patches also can appear on the palms and soles, in the genital areas of both men and women, above the pelvic bone, and on the thighs and calves of the legs. Although psoriasis rarely affects the face in adults, about half of patients develop psoriasis in the scalp. Many patients have only a few patches in this location. In

some cases, however, psoriasis can cover the scalp with thick plaques that may even extend down from the hairline to the forehead. In children, psoriasis is most likely to start in the scalp and spread to other parts of the body; unlike in adults, it also may occur on the face and ears. Plaque psoriasis may persist for long periods. More often it flares up periodically, triggered by certain factors, such as cold weather, infection, or stress.

[0098] Psoriatic arthritis (PsA) is an inflammatory condition that is associated with psoriasis and some evidence suggests that both psoriatic arthritis and psoriasis are caused by the same autoimmune process. Psoriatic arthritis is characterized by stiff, tender, and inflamed joints. Arthritic and skin flare-ups tend to occur at the same time. Psoriatic arthritis usually affects less than five joints, often causing deformities in the fingers and toes. About 80% of PsA patients have psoriasis in the nails, and the arthritis may occur in the knees, hips, elbows, and spine. When PsA affects the spine, it most frequently targets the sacrum (the lowest part of the spine). Although estimates of spine involvement have ranged between 30% and 50%, one study suggests that the sacrum may be affected in more than three-quarters of patients with psoriatic arthritis.

[0100] Although patients with psoriatic arthritis tend to have mild skin manifestations, the disease is systemic; that is, it affects the body as a whole. PsA, therefore, is more serious than the common psoriatic condition.

[0101] Infrequently, the course of PsA has been associated with a syndrome known by the acronym SAPHO, whose letters form the symptoms: Synovitis (inflammation in the joints), Acne, Pustule eruptions, Hyperostosis (abnormal bony growths) and Osteolysis (bone destruction). Estimates on its prevalence among psoriasis patients range from 2% to as high as 42%. Patients at highest risk are those with severe conditions or who have AIDS.

[0102] In addition to plaque psoriasis and psoriatic arthritis, a number of other less common forms of psoriasis have also been described. Examples of these variants of psoriasis, that in no way limit the present invention, are shown in Table 2.

**Table 2 – Less common forms of psoriasis**

<b>Psoriasis Form</b>	<b>Description</b>	<b>Other Factors</b>
<b>Guttate Psoriasis</b>	<p>The patches are teardrop-shaped that erupt suddenly, usually over the trunk and often on the arms, legs, or scalp.</p> <p>The teardrop patches often resolve on their own without treatment.</p>	<p>Guttate psoriasis can occur as the initial case of psoriasis. Usually this event affects children and young adults, often about one to three weeks after a viral or bacterial (usually streptococcal) infection in the lungs or throat. A family history of psoriasis and stressful life events are also highly linked with the onset of guttate psoriasis.</p> <p>Guttate psoriasis can also develop in patients who have had earlier forms of psoriasis. In such cases, it is more likely to emerge in people treated with widespread topical corticosteroid dressings.</p>
<b>Inverse Psoriasis</b>	<p>Patches usually appear as smooth inflamed patches without a scaly surface. They occur in the folds of the skin, such as under the armpits or breast or in the groin.</p>	
<b>Seborrheic Psoriasis</b>	<p>Seborrheic psoriasis appears as red scaly areas in the scalp, behind the ears, above the shoulder blades, in the armpits, the groin, and in the center of the face.</p>	

<p><b>Nail Psoriasis</b></p>	<p>The characteristic signs are tiny white pits scattered in groups across the nail. Long ridges may also develop across and down the nail. Toenails and sometimes fingernails may have yellowish spots. The nail bed often separates from the skin of the finger and collections of dead skin can accumulate underneath the nail.</p>	<p>Over half of patients with psoriasis have abnormal changes in their nails. Such nail changes may appear before psoriatic skin eruptions occur. In some cases, nail psoriasis is the <i>only</i> type of psoriasis.</p>
<p><b>Generalized Erythrodermic Psoriasis.</b> (also called <i>psoriatic exfoliative erythroderm</i>)</p>	<p>In rare severe cases, psoriasis develops into generalized erythrodermic psoriasis</p> <ul style="list-style-type: none"> <li>• The skin surface becomes scaly and red.</li> <li>• The disease covers all or nearly all of the body.</li> </ul>	<p>About 20% of such cases evolve from psoriasis itself. It can also be caused by certain psoriasis treatments. This condition can also erupt after withdrawal from other agents, including corticosteroids or synthetic antimalarial drugs.</p>
<p><b>Pustular Psoriasis</b></p>	<p>Psoriasis patches become pus-filled and blister-like.</p> <p>The blisters eventually turn brown and form a scaly crust or peel off.</p> <p>Pustules usually appear on the hands and feet. (When they form on the palms and soles, the condition is called palmar-plantar pustulosis.)</p>	<p>The condition may erupt as the first occurrence of psoriasis or may evolve from plaque psoriasis. It can also accompany other forms of psoriasis. If pustular psoriasis occurs with generalized erythrodermic psoriasis and becomes widespread, it becomes very dangerous and is referred to as Von Zumbusch psoriasis.</p> <p>A number of conditions may trigger pustular, including the following:</p> <ul style="list-style-type: none"> <li>• Infection</li> <li>• Pregnancy</li> <li>• Certain drugs</li> <li>• Metal allergies</li> </ul>

[0103] As used herein, the term "psoriasis" is to be understood to cover all variants of the disease, including psoriatic arthritis. However, the present invention should not be considered in any way limited to psoriasis which is characterized by any particular set of symptoms, such as those exemplified herein.

[0104] The present invention is predicated in part on the use of genetic agents which facilitate silencing of one or more transcriptionally active genetic regions via RNAi wherein those transcriptionally active genetic regions are directly or indirectly associated with the onset, development, maintenance or progression of psoriasis in a subject. Such transcriptionally active regions are also referred to herein as "psoriasis associated genetic targets" or "PATs". ddRNAi-mediated silencing of one or more PATs effects control of one or more of the onset, development, maintenance or progression of psoriasis in the subject.

[0105] As used herein, the terms "psoriasis associated genetic target" or "PAT" refers to any genetic sequence or transcript thereof which is directly or indirectly associated with the onset, development, maintenance or progression of psoriasis in a vertebrate animal, particularly mammalian animals and most particularly in primate or rodent animals. Accordingly, a PAT may be a gene directly associated with psoriasis or a transcript thereof, a nucleic acid region which encodes for a regulatory RNA, such as an efference RNA (eRNA) which is associated with psoriasis, or the PAT may comprise a protein-encoding or regulatory RNA encoding nucleic acid sequence which itself may not be associated with psoriasis, but the expression of which may modulate the expression of a gene or regulatory RNA which is directly associated with psoriasis. Accordingly, the term PAT should be understood to include genetic targets which are directly or indirectly involved in the onset, development, maintenance or progression of psoriasis in a subject.

[0106] The present invention is predicated in part on the use of ddRNAi to silence the expression of one or more PATs, which in turn controls the onset, development, maintenance or progression of psoriasis in the subject. The term "silencing of expression" in this context includes regulating the amount of functional RNA transcript derived from the PAT. Regulating the amount of functional RNA transcript

may occur by facilitating transcript degradation or facilitating formation of nucleic acid based molecules which inhibit translation. In either case, the genetic agents promote or facilitate post-transcriptional gene silencing. As used herein "functional RNA transcript" refers to an RNA transcript which is able to perform its usual function. For example, in the case of the PAT being a protein encoding gene, a "functional RNA transcript" would be a translatable mRNA. However, in the case of a PAT which encodes a non-translated regulatory RNA, a "functional RNA transcript" would be an RNA transcript capable of effecting regulation of another genetic sequence.

**Table 3** – Exemplary PAT sequences which may be targeted using ddRNAi

<b>PAT</b>	<b>Entrez Gene ID No.</b>
<i>TNF</i> (tumour necrosis factor)3	7124
<i>IL8</i> (interleukin 8)4	3576
<i>HAT</i> (airway trypsin-like protease)4	9407
<i>PSORS1</i> (psoriasis susceptibility 1)	5674
<i>PSORS2</i> (psoriasis susceptibility 2)	5722
<i>PSORS6</i> (psoriasis susceptibility 6)	63869
<i>PSORS4</i> (psoriasis susceptibility 4)	10547
<i>PSORS3</i> (psoriasis susceptibility 3)	7889
<i>PSORS#</i> (psoriasis susceptibility)	65245
<i>PSORS5</i> (psoriasis susceptibility 5)	63870
<i>PSORS1C2</i> (psoriasis susceptibility 1 candidate 2)	170680
<i>PSORS1C1</i> (psoriasis susceptibility 1 candidate 1)	170679
<i>PSORS9</i> (psoriasis susceptibility 9)	359825
<i>PSORS1C3</i> (psoriasis susceptibility 1 candidate 3)	170681
<i>CNFN</i> (cornefelin)	84518
<i>PSORS7</i> (psoriasis susceptibility 7)	94006
<i>PSORS8</i> (psoriasis susceptibility 8)	140454
<i>VDR</i> (vitamin D receptor)	7421
<i>HLA-C</i> (major histocompatibility complex, class I, C)	3107
<i>CCL27 / CTACK</i> (chemokine (C-C motif) ligand 27)	10850

<i>CCL2</i> (chemokine (C-C motif) ligand 2)	6347
<i>S100A7</i> (S100 calcium binding protein A7 (psoriasin 1))	6278
<i>KIR2DS1</i> (killer cell immunoglobulin-like receptor, two domains, short cytoplasmic tail, 1)	3806
<i>IL17</i> (interleukin 17 - cytotoxic T-lymphocyte-associated serine esterase 8)	3605
<i>APP</i> (amyloid beta (A4) precursor protein)	351
<i>CTSB</i> (cathepsin B / $\beta$ -secretase) <sup>1</sup>	1508
<i>FABP5</i> (Fatty Acid Binding Protein 5 (psoriasis associated))	2171
<i>F13A1</i> (coagulation factor XIII, A1 polypeptide)	2162
<i>CD14</i> (CD14 antigen)	929
<i>SLURP2</i> (secreted Ly6/uPAR related protein 2)	432355
<i>RDH-E2</i> (retinal short chain dehydrogenase reductase)	195814
<i>KIR2DL5</i> (killer cell immunoglobulin-like receptor, two domains, long cytoplasmic tail, 5)	57292
<i>HAX1</i> (HS1 binding protein)	10456
<i>IL13RA2</i> (interleukin 13 receptor, alpha 2)	3598
<i>ID1</i> (inhibitor of DNA binding 1, dominant negative helix-loop-helix protein)	3397
<i>HLA-B</i> (major histocompatibility complex, class I, B)	3106
<i>C4B</i> (complement component 4B)	721
<i>C3</i> (complement component 3)	718
<i>ALOX5AP</i> (arachidonate 5-lipoxygenase-activating protein)	241
<i>SLC12A8</i> (solute carrier family 12, potassium/chloride transporters, member 8)	84561
<i>IL20RA</i> (interleukin 20 receptor, alpha)	53832
<i>IL23A</i> (interleukin 23, alpha subunit p19)	51561
<i>IL20</i> (interleukin 20)	50604
<i>TGM5</i> (transglutaminase 5)	9333
<i>IRF2</i> (interferon regulatory factor 2)	3660
<i>IL15</i> (interleukin 15)	3600
<i>C4A</i> (complement component 4A)	720
<i>IGF1</i> (insulin-like growth factor 1 / somatomedin C)	3479
<i>IGF1R</i> (insulin-like growth factor 1 receptor)	3480



[0107] Further exemplary PAT sequences are those set out in Figure 5, while other agents that are useful in conjunction with the present invention will be readily apparent to those of skill in the art.

[0108] Incorporation of RNAi Agents into Carriers, Coatings or Matrices

[0109] As stated previously, the RNAi agents, whether siRNAs or ddRNAs, are formulated with a carrier, which may then be associated with a delivery vehicle such as a matrix, ultimately forming a therapeutic composition or device. The therapeutic composition may be the RNAi agent + the carrier itself that is a flowable liquid, lotion or gel that is applied to the skin. Alternatively, the therapeutic composition may be delivered via a synthetic or naturally-occurring matrix, such as a compress or bandage, that is formulated with the RNAi agent directly, or the synthetic or naturally-occurring matrix may be coated with the RNAi agent + carrier. Either matrix would be applied to the skin.

[0110] Methods for incorporating RNAi agents into a carrier or coating include, but are not limited to, covalent attachment of the RNAi agent with the coating or non-covalent interaction of the RNAi agent with the carrier by using an electrostatic or an ionic attraction between a charged RNAi agent and a component of the coating bearing a complementary charge. The RNAi agents also can be admixed, and not otherwise interact with the carrier or coating. The carriers or coatings also can be fabricated to incorporate the RNAi agents into reservoirs located in the matrix coating. The reservoirs can have a variety of shapes and sizes and they can be produced by an array of methods. For example, the reservoir can be a monolithic structure located in one or more components of the coating. Alternatively, the reservoir can be made up of numerous small microcapsules that are, for example, embedded in the material from which the coating is fabricated. Furthermore, the reservoir can be a coating that includes the RNAi agent diffused throughout, or within a portion of the coating's three-dimensional structure. Reservoirs can be porous structures that allow the RNAi agent to be slowly released from its encapsulation, or the reservoir can include a material that bioerodes following

implantation and allows the drug to be released in a controlled fashion.

[0111] Reversibly Associated RNAi Agents

[0112] In one embodiment of the present invention, if it is desired that the RNAi agent first be associated with a carrier or coating in order to prepare the therapeutic device, but then the RNAi agent or agents be released from the carrier or coating in a controlled manner once the therapeutic device has been applied to the skin (a reversibly-associated RNAi agent). Such a reversibly associated RNAi agent can, for example, be entrapped in a carrier, coating or matrix by adding the agent to the carrier, coating or matrix components during manufacture of the carrier, coating or matrix. In an exemplary embodiment, the RNAi agent is added to a polymer melt or a solution of the polymer. Other methods for reversibly incorporating RNAi agents into a delivery matrix will be apparent to those of skill in the art.

[0113] Examples of such reversible associations include, for example, RNAi agents that are mechanically entrapped within the carrier, coating or matrix and RNAi agents that are encapsulated in structures (e.g., within microspheres, liposomes, etc.) that are themselves entrapped in, or immobilized on, the carrier, coating or matrix. Other reversible associations include, but are not limited to, RNAi agents that are adventitiously adhered to the carrier, coating or matrix by, for example, hydrophobic or ionic interactions and RNAi agents bound to one or more carrier, coating or matrix component by means of a linker cleaved by one or more biologically relevant processes. The reversibly-associated RNAi agents can be exposed on the coating surface or they can be covered with the same or a different carrier or coating, such as a bioerodable polymer, as described below.

[0114] In one embodiment, the surface character of the carrier, coating or matrix material is altered or manipulated by including certain additives or modifiers in the coating material during its manufacture. A method of preparing surface-functionalized polymeric materials by this method is set forth in, for example, U.S. Pat. No. 5,784,164 to Caldwell. In the Caldwell method, additives or modifiers are combined with the polymeric material during its manufacture. These additives or

modifiers include compounds that have affinity sites, compounds that facilitate the controlled release of agents from the polymeric material into the surrounding environment, catalysts, compounds that promote adhesion between the bioactive materials and the coating material and compounds that alter the surface chemistry of the coating material.

[0115] As used herein, the term "affinity site" refers to a site on the polymer that interacts with a complementary site on the RNAi agent, or on the exterior surface of the delivery vehicle to which the carrier, coating or matrix is applied. Affinity sites for the RNAi agent, carrier, or delivery vehicles that are contemplated in the practice of the present invention include such functional groups as hydroxyl, carboxyl, carboxylic acid, amine groups, hydrophobic groups, inclusion moieties (e.g., cyclodextrin, complexing agents), biomolecules (e.g. antibodies, haptens, saccharides, peptides) and the like, that promote physical and/or chemical interaction with the RNAi agent. In such an embodiment, the affinity site interacts with the RNAi agent by non-covalent means. The particular compound employed as the modifier will depend on the chemical functionality of the RNAi agent and the groups on the carrier, coating or matrix. Appropriate functional groups for a particular purpose can be deduced by one of skill in the art.

[0116] In another embodiment, the coating used in the invention is a flowable material such as a lotion or gel that can be applied directly to the skin. Certain embodiments of the flowable material are those that cure to a substantially non-flowable coating *in vivo*. In this case, the carrier itself is the delivery vehicle, and the RNAi agent/carrier combination is the therapeutic device. Materials meeting the flowably/curable criteria include, for example, fibrin sealants, hydrophobic poly(hydroxy acids) and the like. The amount of the RNAi agent contained in the flowable material varies depending on a number of factors, including, for example, the activity of the particular RNAi agent or agents being delivered and the tenaciousness with which the RNAi agent adheres to the carrier, coating or matrix.

[0117] In another embodiment, the RNAi agent interacts with a surfactant that adheres to the carrier, coating or matrix material. Presently preferred surfactants are

selected from benzalkonium halides and sterylalkonium halides. Other surfactants suitable for use in the present invention are known to those of skill in the art.

[0118] Covalently Attached RNAi Agents

[0119] In another embodiment, the RNAi agent is covalently bonded to a reactive group located on one or more components of the carrier or coating. The art is replete with methods for preparing derivatized, polymerizable monomers, attaching nucleic acids onto polymeric surfaces and derivatizing nucleic acids and polymers to allow for this attachment (see, for example, Hermanson, *Bioconjugate Techniques*, Academic Press, 1996, and references therein). Common approaches include the use of coupling agents such as glutaraldehyde, cyanogen bromide, p-benzoquinone, succinic anhydrides, carbodiimides, diisocyanates, ethyl chloroformate, dipyrindyl disulfide, epichlorohydrin, azides, among others, which serve as attachment vehicles for coupling reactive groups of derivatized nucleic acid molecules to reactive groups on a monomer or a polymer.

[0120] A polymer can be functionalized with reactive groups by, for example, including a moiety bearing a reactive group as an additive to a blend during manufacture of the polymer or polymer precursor. The additive is dispersed throughout the polymer matrix, but does not form an integral part of the polymeric backbone. In this embodiment, the surface of the polymeric material is altered or manipulated by the choice of additive or modifier characteristics. The reactive groups of the additive are used to bind the one or more RNAi agents to the polymer.

[0121] A useful method for preparing surface-functionalized polymeric materials by this method is set forth in, for example, Caldwell, *supra*. In the Caldwell method, additives or modifiers are combined with the polymeric material during its manufacture. These additives or modifiers include compounds that have reactive sites, compounds that facilitate the controlled release of agents from the polymeric material into the surrounding environment, catalysts, compounds that promote adhesion between bioactive materials (such as an RNAi agent) and the polymeric material and compounds that alter the surface chemistry of the polymeric material.

In another embodiment, polymerizable monomers bearing reactive groups are incorporated in the polymerization mixture. The functionalized monomers form part of the polymeric backbone and, preferably, present their reactive groups on the surface of the polymer.

[0122] Reactive groups contemplated in the practice of the present invention include functional groups, such as hydroxyl, carboxyl, carboxylic acid, amine groups, and the like, that promote physical and/or chemical interaction with the bioactive material. The particular compound employed as the modifier will depend on the chemical functionality of the biologically active RNAi agent and can readily be deduced by one of skill in the art. In the present embodiment, the reactive site binds a bioactive agent by covalent means. It will, however, be apparent to those of skill in the art that these reactive groups can also be used to adhere the RNAi agents to the polymer by hydrophobic/hydrophilic, ionic and other non-covalent mechanisms.

[0123] In addition to manipulating the composition and structure of the polymer during manufacture, a preferred polymer also can be modified using a surface derivitization technique. There are a number of surface-derivatization techniques appropriate for use in fabricating the RNAi agent/carrier and, ultimately, the therapeutic devices of the present invention. These techniques for creating functionalized polymeric surfaces (e.g., grafting techniques) are well known to those skilled in the art. For example, techniques based on ceric ion initiation, ozone exposure, corona discharge, UV irradiation and ionizing radiation ( $^{60}\text{Co}$ , X-rays, high energy electrons, plasma gas discharge) are known and can be used in the practice of the present invention.

[0124] Substantially any reactive group that can be reacted with a complementary component on an RNAi agent can be incorporated into a polymer and used to covalently attach the RNAi agent to the carrier coating of use in the invention. In a preferred embodiment, the reactive group is selected from amine-containing groups, hydroxyl groups, carboxyl groups, carbonyl groups, and combinations thereof. In a further preferred embodiment, the reactive group is an

amino group.

[0125] Aminated polymeric materials useful in practicing the present invention can be readily produced through a number of methods well known in the art. For example, amines may be introduced into a preformed polymer by plasma treatment of materials with ammonia gas as found in Holmes and Schwartz, Composites Science and Technology, 38: 1-21 (1990). Alternatively, amines can be provided by grafting acrylamide to the polymer followed by chemical modification to introduce amine moieties by methods well known to those skilled in the art; e.g., by the Hofmann rearrangement reaction. Also, grafted acrylamide-containing polymer may be prepared by radiation grafting as set forth in U.S. Pat. No. 3,826,678 to Hoffman et al. A grafted N-(3-aminopropyl)methacrylamide-containing polymer may be prepared by ceric ion grafting as set forth in U.S. Pat. No. 5,344,455 to Keogh et al. Polyvinylamines or polyalkylimines also can be covalently attached to polyurethane surfaces according to the method taught by U.S. Pat. No. 4,521,564 to Solomone et al. Alternatively, for example, aminosilane may be attached to the surface as set forth in U.S. Pat. No. 5,053,048 to Pinchuk.

[0126] In yet another embodiment, a polymeric coating material, or a precursor material, is exposed to a high frequency plasma with microwaves or, alternatively, to a high frequency plasma combined with magnetic field support to yield the desired reactive surfaces bearing at least a substantial portion of reactant amino groups upon the substrate to be derivatized with the RNAi agent.

[0127] A functionalized carrier or coating surface also can be prepared by, for example, first submitting a carrier coating component to a chemical oxidation step. This chemical oxidation step is then followed, for example, by exposing the oxidized substrate to one or more plasma gases containing ammonia and/or organic amine(s) which react with the treated surface. In one embodiment, the gas is selected from the group consisting of ammonia, organic amines, nitrous oxide, nitrogen, and combinations thereof. The nitrogen-containing moieties derived from this gas are preferably selected from amino groups, amido groups, urethane groups, urea groups, and combinations thereof, more preferably primary amino groups,

secondary amino groups, and combinations thereof. In another aspect of this embodiment, the nitrogen source is an organic amine. Examples of suitable organic amines include, but are not limited to, methylamine, dimethylamine, ethylamine, diethylamine, ethylmethylamine, n-propylamine, allylamine, isopropylamine, n-butylamine, n-butylmethylamine, n-amylamine, n-hexylamine, 2-ethylhexylamine, ethylenediamine, 1,4-butanediamine, 1,6-hexanediamine, cyclohexylamine, n-methylcyclohexylamine, ethyleneimine, and the like. In a further aspect, the chemical oxidation step is supplemented with, or replaced by, submitting the polymer to one or more exposures to plasma-gas that contains oxygen. In yet a further preferred embodiment, the oxygen-containing plasma gas further contains argon (Ar) gas to generate free radicals. Immediately after a first-step plasma treatment with oxygen-containing gases, or oxygen/argon plasma gas combinations, the oxidized polymer is preferably functionalized with amine groups. As mentioned above, functionalization with amines can be performed with plasma gases such as ammonia, volatile organic amines, or mixtures thereof.

[0128] In an exemplary embodiment utilizing ammonia and/or organic amines, or mixtures thereof, as the plasma gases, a frequency in the radio frequency (RF) range of from about 13.0 MHz to about 14.0 MHz is used. A generating power of from 0.1 Watts per square centimeter to about 0.5 Watts per square centimeter of surface area of the electrodes of the plasma apparatus is preferably utilized. An exemplary plasma treatment includes evacuating the plasma reaction chamber to a desired base pressure of from about 10 to about 50 mTorr. After the chamber is stabilized to a desired working pressure, ammonia and/or organic amine gases are introduced into the chamber. Preferred flow rates are typically from about 200 to about 650 standard mL per minute. Typical gas pressure ranges from about 0.01 to about 0.5 Torr, and preferably from about 0.2 to about 0.4 Torr. A current having the desired frequency and level of power is supplied by means of electrodes from a suitable external power source. Power output is up to about 500 Watts, preferably from about 100 to about 400 Watts. The plasma treatment can be performed by means of a continuous or batch process.

[0129] Optimization procedures for the plasma treatment and the effect of

these procedures on the characteristics and the performance of the reactive polymers can be determined by, for example, evaluating the extent of substrate functionalization. Methods for characterizing functionalized polymers are well known in the art.

[0130] The result of the above-described exemplary methods is preferably a polymeric surface that contains a significant number of primary and/or secondary amino groups. These groups are preferably readily reactive at room temperature with an inherent, or an appended, reactive functional group on the RNAi agents. Once the amine-containing polymeric carrier coating is prepared, it can be used to covalently bind the RNAi agents using a variety of functional groups including, for example, ketones, aldehydes, activated carboxyl groups (e.g. activated esters), alkyl halides and the like.

[0131] Synthesis of specific RNAi agent/carrier conjugates is generally accomplished by: 1) providing a carrier or coating component comprising an activated polymer, such as an acrylic acid, and an RNAi agent having a position thereon which will allow a linkage to form; 2) reacting the complementary substituents of the RNAi agent and the carrier coating component in an inert solvent, such as methylene chloride, chloroform or DMF, in the presence of a coupling reagent, such as 1,3-diisopropylcarbodiimide or any suitable dialkyl carbodiimide (Sigma Chemical), and a base, such as dimethylaminopyridine, diisopropyl ethylamine, pyridine, triethylamine, etc. Alternative specific syntheses are readily accessible to those of skill in the art (see, for example, Greenwald et al., U.S. Pat. No. 5,880,131).

[0132] One skilled in the art understands that in the synthesis of compounds useful in practicing the present invention, one may need to protect various reactive functionalities on the starting compounds and intermediates while a desired reaction is carried out on other portions of the molecule. After the desired reactions are complete, or at any desired time, normally such protecting groups will be removed by, for example, hydrolytic or hydrogenolytic means. Such protection and deprotection steps are conventional in organic chemistry. One skilled in the art is



referred to *Protective Groups in Organic Chemistry*, McOmie, ed., Plenum Press, NY, N.Y. (1973); and, *Protective Groups in Organic Synthesis*, Greene, ed., John Wiley & Sons, NY (1981) for the teaching of protective groups which may be useful in the preparation of compounds of the present invention.

[0133]     Delivery Vehicle Formats

[0134]     The present invention includes providing a therapeutic device to treat psoriasis. In one embodiment, the site is covered or partially covered with a flowable liquid or semi-solid liquid comprising an RNAi agent, where the RNAi agent/carrier combination itself is the therapeutic device. In another embodiment, one or more RNAi agents are associated with a carrier or coating, which is then associated with a delivery vehicle such as a matrix, such as a compress or bandage, to form a therapeutic device. The carrier or coating can take a number of forms. For example, as described herein, useful carriers or coatings can be in the form of foams, gels, suspensions, microcapsules, solid polymeric materials and fibrous or porous structures. The carrier, coating or matrix can be multilayered with one or more of the layers including an RNAi agent. Moreover, a carrier or coating can be layered on a component impregnated with the RNAi agent. Many materials that are appropriate for use as carriers or coatings or matrices in the present methods are known in the art and both natural and synthetic materials are useful in practicing the present invention.

[0135]     Selection of Carrier, Coating, or Matrix Materials

[0136]     Suitable polymers that can be used as carrier, coating, or matrix material in the present invention include, but are not limited to, water-soluble and water-insoluble, biodegradable, bioerodable or nonbiodegradable polymers. The carrier, coating, or matrix is preferably sufficiently porous, or capable of becoming sufficiently porous, to permit efflux of the RNAi agents from the coating. The carrier, coating, or matrix also preferably is sufficiently non-inflammatory and is biocompatible so that inflammatory responses do not prevent the delivery of the RNAi agents to the epithelial tissue. It is advantageous if the carrier, coating, or

matrix also provides at least partial protection of the RNAi agents from the adverse effects of nucleases and other relevant degradative species. In addition, it is advantageous for the carrier, coating, or matrix to produce controlled, sustained delivery of the one or more RNAi agents.

[0137] Many polymers can be utilized to form the carrier, coating, or matrix. A carrier, coating, or matrix can be, for example, a gel, such as a hydrogel, organogel or thermoreversible gel. Other useful polymer types include, but are not limited to, thermoplastics and films. Moreover, the carrier, coating, or matrix can comprise a homopolymer, copolymer or a blend of these polymer types. The carrier, coating, or matrix can also include an RNAi agent-loaded microparticle dispersed within a component of the carrier, coating, or matrix, which serves as a dispersant for the microparticles. Microparticles include, for example, microspheres, microcapsules and liposomes.

[0138] The carrier, coating, or matrix can serve to immobilize the microparticles at a particular site, enhancing targeted delivery of the encapsulated RNAi agents. Rapidly bioerodible polymers such as polylactide-co-glycolide, polyanhydrides, and polyorthoesters, whose carboxylic groups are exposed on the surface are useful in the coatings of use in the invention. In addition, polymers containing labile bonds, such as polyesters, are well known for their hydrolytic reactivity. The hydrolytic degradation rates of the carrier, coating, or matrix can generally be altered by simple changes in the polymer backbone.

[0139] The carrier, coating, or matrix can be made up of natural and/or synthetic polymeric materials. Representative natural polymers of use as coatings in the present invention include, but are not limited to, proteins, such as zein, modified zein, casein, gelatin, gluten, serum albumin, or collagen, and polysaccharides, such as cellulose, dextrans, and polyhyaluronic acid. Also of use in practicing the present invention are materials, such as collagen and gelatin, which have been widely used on implantable devices, such as textile grafts (see, for example, Hoffman, et al., U.S. Pat. No. 4,842,575, and U.S. Pat No. 5,034,265), but which have not been utilized as components of adherent coatings for periadventitial delivery of RNAi agents, such

as those preventing or retarding the development of psoriasis. Hydrogel or sol-gel mixtures of polysaccharides are also known. Furthermore, fibrin, an insoluble protein formed during the blood clotting process, has also been used as a sealant for porous implantable devices (see, for example, Sawhey et al., U.S. Pat. No. 5,900,245). Useful fibrin sealant compositions are disclosed in, for example, Edwardson et al., U.S. Pat. No. 5,770,194, and U.S. Pat. No. 5,739,288. These and other naturally based agents, alone or in combination, can be used as a carrier, coating, or matrix in practicing the present invention.

[0140] The carrier, coating, or matrix may comprise a synthetic polymer. Representative synthetic polymers include, but are not limited to, polyphosphazines, poly(vinyl alcohols), polyamides, polycarbonates, polyalkylenes, polyacrylamides, polyalkylene glycols, polyalkylene oxides, polyalkylene terephthalates, polyvinyl ethers, polyvinyl esters, polyvinyl halides, polyvinylpyrrolidone, polyglycolides, polysiloxanes, polyurethanes, poly(methyl methacrylate), poly(ethyl methacrylate), poly(butyl methacrylate), poly(isobutyl methacrylate), poly(hexyl methacrylate), poly(isodecyl methacrylate), poly(lauryl methacrylate), poly(phenyl methacrylate), poly(methyl acrylate), poly(isopropyl acrylate), poly(isobutyl acrylate), poly(octadecyl acrylate) polyethylene, polypropylene, poly(ethylene glycol), poly(ethylene oxide), poly(ethylene terephthalate), poly(vinyl acetate), polyvinyl chloride, polystyrene, polyvinyl pyrrolidone, pluronics and polyvinylphenol and copolymers thereof.

[0141] Also, the carrier, coating, or matrix may comprise a synthetically-modified natural polymer. Synthetically modified natural polymers include, but are not limited to, alkyl celluloses, hydroxyalkyl celluloses, cellulose ethers, cellulose esters, and nitrocelluloses. Particularly preferred members of the broad classes of synthetically modified natural polymers include, but are not limited to, methyl cellulose, ethyl cellulose, hydroxypropyl cellulose, hydroxypropyl methyl cellulose, hydroxybutyl methyl cellulose, cellulose acetate, cellulose propionate, cellulose acetate butyrate, cellulose acetate phthalate, carboxymethyl cellulose, cellulose triacetate, cellulose sulfate sodium salt, and polymers of acrylic and methacrylic esters and alginic acid.

[0142] These and the other polymers discussed herein can be readily obtained

from commercial sources such as Sigma Chemical Co. (St. Louis, Mo.), Polysciences (Warrenton, Pa.), Aldrich (Milwaukee, Wis.), Fluka (Ronkonkoma, N.Y.), and BioRad (Richmond, Calif.), or else synthesized from monomers obtained from these suppliers using standard techniques.

[0143] Biodegradable and Bioresorbable Carrier, Coating, or Matrix Materials

[0144] RNAi agents in combination with a carrier, coating, or matrix may have intrinsic and controllable biodegradability, if desired, so that the RNAi agents persist for about a week to about six months or longer. The carriers, coatings, or matrices also are preferably biocompatible, non-toxic, contain no significantly toxic monomers and degrade into non-toxic components. Moreover, preferred carriers, coatings, or matrices are chemically compatible with the RNAi agents to be delivered, and tend not to denature the RNAi agents. Still further preferred carriers, coatings, or matrices are, or become, sufficiently porous to allow the incorporation of RNAi agents and their subsequent liberation from the coating by diffusion, erosion or a combination thereof. The carriers, coatings, or matrices should also remain at the site of application by adherence or by geometric factors, such as by being formed in place or softened and subsequently molded or formed into fabrics, wraps, gauzes, particles (e.g., microparticles), and the like. Types of monomers, macromers, and polymers that can be used are described in more detail below.

[0145] Representative biodegradable polymers include, but are not limited to, polylactides, polyglycolides and copolymers thereof, poly(ethylene terephthalate), poly(butyric acid), poly(valeric acid), poly(lactide-co-caprolactone), poly(lactide-co-glycolide), polyanhydrides, polyorthoesters, blends and copolymers thereof. Of particular use are compositions that form gels, such as those including collagen, pluronics and the like.

[0146] Preferred carriers, coatings, or matrices are water-insoluble materials that comprise within at least a portion of their structure, a bioresorbable molecule. An example of such a carrier, coating, or matrix is one that includes a water-insoluble copolymer, which has a bioresorbable region, a hydrophilic region and a plurality of

crosslinkable functional groups per polymer chain.

[0147] For purposes of the present invention, "water-insoluble materials" includes copolymers that are substantially insoluble in water or water-containing environments. Thus, although certain regions or segments of the copolymer may be hydrophilic or even water-soluble, the copolymer molecule, as a whole, does not by any substantial measure dissolve in water or water-containing environments.

[0148] For purposes of the present invention, the term "bioresorbable molecule" includes a region that is capable of being metabolized or broken down and resorbed and/or eliminated through normal excretory routes by the body. Such metabolites or break down products are preferably substantially non-toxic to the body.

[0149] The bioresorbable region is preferably hydrophobic. In another embodiment, however, the bioresorbable region may be designed to be hydrophilic so long as the copolymer composition as a whole is not rendered water-soluble. Thus, the bioresorbable region is designed based on the preference that the copolymer, as a whole, remains water-insoluble. Accordingly, the relative properties, i.e., the kinds of functional groups contained by, and the relative proportions of the bioresorbable region, and the hydrophilic region are selected to ensure that useful bioresorbable compositions remain water-insoluble.

[0150] Exemplary resorbable carriers, coatings, or matrices include, for example, synthetically produced resorbable block copolymers of poly( $\alpha$ -hydroxy-carboxylic acid)/poly(oxyalkylene, (see, Cohn et al., U.S. Pat. No. 4,826,945). These copolymers are not crosslinked and are water-soluble so that the body can excrete the degraded block copolymer compositions. See, Younes et al., J. Biomed. Mater. Res. 21: 1301-1316 (1987); and Cohn et al., J. Biomed. Mater. Res. 22: 993-1009 (1988).

[0151] Presently preferred bioresorbable polymers include one or more components selected from poly(esters), poly(hydroxy acids), poly(lactones), poly(amides), poly(ester-amides), poly (amino acids), poly(anhydrides), poly(orthoesters), poly(carbonates), poly(phosphazines), poly(phosphoesters),

poly(thioesters), polysaccharides and mixtures thereof. In some embodiments, the bioresorbable polymer includes a poly(hydroxy) acid component. Of the poly(hydroxy) acids, polylactic acid, polyglycolic acid, polycaproic acid, polybutyric acid, polyvaleric acid and copolymers and mixtures thereof are preferred. In addition to forming fragments that are absorbed in vivo ("bioresorbed"), some polymeric coatings for use in the methods of the invention can also form an excretable and/or metabolizable fragment.

[0152] Higher order copolymers can also be used as carriers, coatings, or matrices in the methods of the present invention. For example, Casey et al., U.S. Pat. No. 4,438,253 discloses tri-block copolymers produced from the transesterification of poly(glycolic acid) and an hydroxyl-ended poly(alkylene glycol). Such compositions are disclosed for use as resorbable monofilament sutures. The flexibility of such compositions is controlled by the incorporation of an aromatic orthocarbonate, such as tetra-p-tolyl orthocarbonate into the copolymer structure.

[0153] Other coatings based on lactic and/or glycolic acids can also be utilized. For example, Spinu, U.S. Pat. No. 5,202,413, discloses biodegradable multi-block copolymers having sequentially ordered blocks of polylactide and/or polyglycolide produced by ring-opening polymerization of lactide and/or glycolide onto either an oligomeric diol or a diamine residue followed by chain extension with a difunctional compound, such as, a diisocyanate, diacylchloride or dichlorosilane.

[0154] The monomers, polymers and copolymers of use in the present invention may, in some embodiments, form a stable aqueous emulsion, and more preferably a flowable liquid. The relative proportions or ratios of the bioresorbable and hydrophilic regions, respectively, are preferably selected to render the block copolymer composition water-insoluble. Furthermore, these compositions are preferably sufficiently hydrophilic to form a hydrogel in aqueous environments when crosslinked.

[0155] The specific ratio of the two regions of the block copolymer composition for use as carriers, coatings, or matrices in the present invention will vary depending

upon the intended application and will be affected by the desired physical properties of the implantable coating, the site of implantation, as well as other factors. For example, the composition of the present invention will preferably remain substantially water-insoluble when the ratio of the water-insoluble region to the hydrophilic region is from about 10:1 to about 1:1, on a percent by weight basis.

[0156] Bioresorbable regions of carriers, coatings or matrices useful in the present invention can be designed to be hydrolytically and/or enzymatically cleavable. For purposes of the present invention, "hydrolytically cleavable" refers to the susceptibility of the copolymer, especially the bioresorbable region, to hydrolysis in water or a water-containing environment. Similarly, "enzymatically cleavable" as used herein refers to the susceptibility of the copolymer, especially the bioresorbable region, to cleavage by endogenous or exogenous enzymes. As set forth above, the some compositions also include a hydrophilic region. Although some compositions contain a hydrophilic region, in other coatings, this region is designed and/or selected so that the composition as a whole, remains substantially water-insoluble.

[0157] When placed within the body, the hydrophilic region can be processed into excretable and/or metabolizable fragments. Thus, the hydrophilic region can include, for example, polyethers, polyalkylene oxides, polyols, poly(vinyl pyrrolidone), poly(vinyl alcohol), poly(alkyl oxazolines), polysaccharides, carbohydrates, peptides, proteins and copolymers and mixtures thereof. Furthermore, the hydrophilic region can also be, for example, a poly(alkylene) oxide. Such poly(alkylene) oxides can include, for example, poly(ethylene) oxide, poly(propylene) oxide and mixtures and copolymers thereof.

[0158] Concerning the disposition of the RNAi agents in the carriers, coatings, or matrices, substantially any combination of RNAi agent and carriers, coatings, or matrices that is of use in achieving the object of the present invention is contemplated by this invention. In some embodiments, the RNAi agent is dispersed in a resorbable coating that imparts controlled release properties to the RNAi agent. The controlled release properties can result from, for example, a resorbable polymer that is cross-linked with a degradable cross-linking agent. Alternatively, the

controlled release properties can arise from a resorbable polymer that incorporates the RNAi agent in a network of pores formed during the cross-linking process or gelling. In another embodiment, the RNAi agent is loaded into microspheres, which are themselves biodegradable and the microspheres are embedded in the carriers, coatings, or matrices. Many other appropriate RNAi agent/coating/matrix formats will be apparent to those of skill in the art.

[0159] In another preferred embodiment, an underlying polymeric component of a carrier, coating, or matrix of use in the invention is first impregnated with the RNAi agent and a resorbable polymer is layered onto the underlying component. In this embodiment, the impregnated component serves as a reservoir for the RNAi agent, which can diffuse out through pores in a resorbable polymer network, through voids in a polymer network created as a resorbable polymer degrades *in vivo*, or through a layer of a gel-like coating. Other controlled release formats utilizing a polymeric substrate, an RNAi agent and a carrier, coating, or matrix will be apparent to those of skill in the art.

[0160] Hydrogel-based Carriers, Coatings, or Matrices

[0161] Also contemplated for use in the practice of the present invention as a carrier or coating composition are hydrogels. Hydrogels are polymeric materials that are capable of absorbing relatively large quantities of water. Examples of hydrogel forming compounds include, but are not limited to, polyacrylic acids, sodium carboxymethylcellulose, polyvinyl alcohol, polyvinyl pyrrolidone, gelatin, carrageenan and other polysaccharides, hydroxyethylenemethacrylic acid (HEMA), as well as derivatives thereof, and the like. Hydrogels can be produced that are stable, biodegradable and bioresorbable. Moreover, hydrogel compositions can include subunits that exhibit one or more of these properties.

[0162] Bio-compatible hydrogel compositions whose integrity can be controlled through crosslinking are known and are presently preferred for use in the methods of the invention. For example, Hubbell et al., U.S. Pat. No. 5,410,016, and U.S. Pat. No. 5,529,914, disclose water-soluble systems, which are crosslinked block



copolymers having a water-soluble central block segment sandwiched between two hydrolytically labile extensions. Such copolymers are further end-capped with photopolymerizable acrylate functionalities. When crosslinked, these systems become hydrogels. The water soluble central block of such copolymers can include poly(ethylene glycol); whereas, the hydrolytically labile extensions can be a poly(.alpha.-hydroxy acid), such as polyglycolic acid or polylactic acid. See, Sawhney et al., Macromolecules 26: 581-587 (1993).

[0163] In yet another embodiment, the RNAi agent is dispersed in a hydrogel that is cross-linked to a degree sufficient to impart controlled release properties to the RNAi agent. The controlled release properties can result from, for example, a hydrogel that is cross-linked with a degradable cross-linking agent. Alternatively, the controlled release properties can arise from a hydrogel that incorporates the RNAi agent in a network of pores formed during the cross-linking process.

[0164] In another preferred embodiment, the gel is a thermoreversible gel. Thermoreversible gels including components, such as pluronics, collagen, gelatin, hyaluronic acid, polysaccharides, polyurethane hydrogel, polyurethane-urea hydrogel and combinations thereof are presently preferred.

[0165] In yet another embodiment, a component of the carrier, coating, or matrix is first impregnated with the RNAi agent and a hydrogel is layered onto the impregnated coating component. In this embodiment, the impregnated coating component serves as a reservoir for the RNAi agent, which can diffuse out through pores in the hydrogel network or, alternatively, can diffuse out through voids in the network created as the hydrogel degrades *in vivo* (see, for example, Ding et al., U.S. Pat. No. 5,879,697 and U.S. Pat. No. 5,837,313). Other controlled release formats utilizing a polymeric substrate, an RNAi agent and a hydrogel will be apparent to those of skill in the art.

[0166] As set forth above, useful carriers, coatings, or matrices of the present invention can also include a plurality of crosslinkable functional groups. Any crosslinkable functional group can be incorporated into these compositions so long

as it permits or facilitates the formation of a hydrogel. Preferably, the crosslinkable functional groups of the present invention are olefinically unsaturated groups. Suitable olefinically unsaturated functional groups include without limitation, for example, acrylates, methacrylates, butenates, maleates, allyl ethers, allyl thioesters and N-allyl carbamates. In some embodiments, the crosslinking agent is a free radical initiator, such as for example, 2,2'-azobis (N,N'dimethyleneisobutyramidine) dihydrochloride. The crosslinkable functional groups can be present at any point along the polymer chain of the present composition so long as their location does not interfere with the intended function thereof. Furthermore, the crosslinkable functional groups can be present in the polymer chain of the present invention in numbers greater than two, so long as the intended function of the present composition is not compromised. An example of a coating having the above-recited characteristics is found in, for example, Loomis, U.S. Pat. No. 5,854,382. This coating is exemplary of the types of coatings that can be used in the invention.

[0167] Also contemplated by the present invention is the use of carriers, coatings, or matrices that are capable of promoting the release of an RNAi agent from the coating. For example, in some embodiments, the RNAi agent is dispersed throughout a hydrogel. As the hydrogel degrades by hydrolysis or enzymatic action, the RNAi agent is released. Alternatively, the coating may promote the release of a biologically active material by forming pores once the resulting article is placed in a particular environment (e.g., *in vivo*). In one embodiment, the pores communicate with a reservoir containing the RNAi agent. Other such coating components that promote the release of an RNAi agent from materials are known to those of skill in the art.

[0168] Microencapsulation of RNAi Agents

[0169] In another embodiment, the RNAi agent or agents are incorporated into a polymeric component by encapsulation in a microcapsule. The microcapsule is preferably fabricated from a material different from that of the bulk of the carrier, coating, or matrix. Preferred microcapsules are those which are fabricated from a material that undergoes erosion in the host, or those which are fabricated such that

they allow the RNAi agent to diffuse out of the microcapsule. Such microcapsules can be used to provide for the controlled release of the encapsulated RNAi agent from the microcapsules.

[0170] Numerous methods are known for preparing microparticles of any particular size range. In the various delivery vehicles of the present invention, the microparticle sizes may range from about 0.2  $\mu\text{m}$  up to about 100  $\mu\text{m}$ . Synthetic methods for gel microparticles, or for microparticles from molten materials are known, and include polymerization in emulsion, in sprayed drops, and in separated phases. For solid materials or preformed gels, known methods include wet or dry milling or grinding, pulverization, size separation by air jet, sieve, and the like.

[0171] Microparticles can be fabricated from different polymers using a variety of different methods known to those skilled in the art. Exemplary methods include those set forth below detailing the preparation of polylactic acid and other microparticles. Polylactic acid microparticles are preferably fabricated using one of three methods: solvent evaporation, as described by Mathiowitz, et al., J. Scanning Microscopy 4:329 (1990); Beck, et al., Fertil. Steril. 31: 545 (1979); and Benita, et al., J. Pharm. Sci. 73: 1721 (1984); hot-melt microencapsulation, as described by Mathiowitz, et al., Reactive Polymers 6: 275 (1987); and spray drying. Exemplary methods for preparing microencapsulated bioactive materials useful in practicing the present invention are set forth below.

[0172] In the solvent evaporation method, the microcapsule polymer is dissolved in a volatile organic solvent, such as methylene chloride. The RNAi agent (either soluble or dispersed as fine particles) is added to the solution, and the mixture is suspended in an aqueous solution that contains a surface active agent such as poly(vinyl alcohol). The resulting emulsion is stirred until most of the organic solvent has evaporated, leaving solid microparticles. The solution is loaded with the RNAi agent and suspended in vigorously stirred distilled water containing poly(vinyl alcohol) (Sigma). After a period of stirring, the organic solvent evaporates from the polymer, and the resulting microparticles are washed with water and dried overnight in a lyophilizer. Microparticles with different sizes (1-1000  $\mu\text{m}$ ) and morphologies

can be obtained by this method. This method is useful for relatively stable polymers like polyesters and polystyrene. Labile polymers such as polyanhydrides, may degrade during the fabrication process due to the presence of water. For these polymers, the following two methods, which are performed in completely anhydrous organic solvents, are preferably used.

[0173] In the hot melt encapsulation method, the polymer is first melted and then mixed with the solid particles of biologically active material that have preferably been sieved to less than 50 microns. The mixture is suspended in a non-miscible solvent (like silicon oil) and, with continuous stirring, heated to about 5°C above the melting point of the polymer. Once the emulsion is stabilized, it is cooled until the polymer particles solidify. The resulting microparticles are washed by decantation with a solvent such as petroleum ether to give a free-flowing powder. Microparticles with sizes ranging from about 1 to about 1000 microns are obtained with this method. The external surfaces of capsules prepared with this technique are usually smooth and dense. This procedure is preferably used to prepare microparticles made of polyesters and polyanhydrides.

[0174] The solvent removal technique is preferred for polyanhydrides. In this method, the RNAi agent is dispersed or dissolved in a solution of the selected polymer in a volatile organic solvent like methylene chloride. This mixture is suspended by stirring in an organic oil (such as silicon oil) to form an emulsion. Unlike solvent evaporation, this method can be used to make microparticles from polymers with high melting points and different molecular weights. Microparticles that range from about 1 to about 300  $\mu\text{m}$  can be obtained by this procedure. The external morphology of spheres produced with this technique is highly dependent on the type of polymer spray drying, the polymer is dissolved in methylene chloride. A known amount of the RNAi agent is suspended or co-dissolved in the polymer solution. The solution or the dispersion is then spray-dried. Microparticles ranging between about 1 to about 10  $\mu\text{m}$  are obtained with a morphology which depends on the type of polymer used.

[0175] In one embodiment, the RNAi agent is encapsulated in microcapsules that

comprise a sodium alginate envelope. Microparticles made of gel-type polymers, such as alginate, are produced through traditional ionic gelation techniques. The polymers are first dissolved in an aqueous solution, mixed with barium sulfate or some bioactive agent, and then extruded through a microdroplet forming device, which in some instances employs a flow of nitrogen gas to break off the droplet. A slowly stirred (approximately 100-170 RPM) ionic hardening bath is positioned below the extruding device to catch the forming microdroplets. The microparticles are left to incubate in the bath for about twenty to thirty minutes in order to allow sufficient time for gelation to occur. Microparticle size is controlled by using various size extruders or varying either the nitrogen gas or polymer solution flow rates.

[0176] Liposomes can aid in the delivery of the RNA agents (whether siRNAi agents or ddRNAi agents) to a particular tissue and also can increase the half-life of the RNA agent. Liposomes are commercially available from a variety of suppliers. Alternatively, liposomes can be prepared according to methods known to those skilled in the art, for example, as described in Eppstein et al., U.S. Pat. No. 4,522,811. In general, liposomes are formed from standard vesicle-forming lipids, which generally include neutral or negatively charged phospholipids and a sterol, such as cholesterol. The selection of lipids is generally guided by consideration of factors such as the desired liposome size and half-life of the liposomes in the blood stream. A variety of methods are known for preparing liposomes, for example as described in Szoka et al., Ann. Rev. Biophys. Bioeng. 9: 467 (1980); and U.S. Pat. Nos. 4,235,871, 4,501,728, 4,837,028, and 5,019,369. In one embodiment, the liposomes encapsulating the RNAi agent according to the present invention comprise a ligand molecule that can target the liposome to a particular cell or tissue at or near the site of psoriasis. Ligands which bind to receptors prevalent in epithelial tissue, such as monoclonal antibodies that bind to epithelial tissue

[0177] In one embodiment, the liposomes encapsulating the RNAi agents of the present invention are modified so as to avoid clearance by the mononuclear macrophage and reticuloendothelial systems, for example by having opsonization-inhibition moieties bound to the surface of the structure. In one embodiment, a liposome of the invention can comprise both opsonization-inhibition

moieties and a ligand. Opsonization-inhibiting moieties for use in preparing the liposomes in one embodiment of the present invention are large hydrophilic polymers that are bound to the liposome membrane. As used herein, an opsonization inhibiting moiety is "bound" to a liposome membrane when it is chemically or physically attached to the membrane, e.g., by the intercalation of a lipid-soluble anchor into the membrane itself, or by binding directly to active groups of membrane lipids. These opsonization-inhibiting hydrophilic polymers form a protective surface layer which significantly decreases the uptake of the liposomes by the macrophage-monocyte system ("MMS") and reticuloendothelial system ("RES"); e.g., as described in U.S. Pat. No. 4,920,016. Liposomes modified with opsonization-inhibition moieties thus remain in the circulation much longer than unmodified liposomes. For this reason, such liposomes are sometimes called "stealth" liposomes. Stealth liposomes are known to accumulate in tissues fed by porous or "leaky" microvasculature. In addition, the reduced uptake by the RES lowers the toxicity of stealth liposomes by preventing significant accumulation in the liver and spleen.

[0178] Opsonization inhibiting moieties suitable for modifying liposomes are preferably water-soluble polymers with a molecular weight from about 500 to about 40,000 daltons, and more preferably from about 2,000 to about 20,000 daltons. Such polymers include polyethylene glycol (PEG) or polypropylene glycol (PPG) derivatives; e.g., methoxy PEG or PPG, and PEG or PPG stearate; synthetic polymers such as polyacrylamide or poly N-vinyl pyrrolidone; linear, branched, or dendrimeric polyamidoamines; polyacrylic acids; polyalcohols, e.g., polyvinylalcohol and polyxylitol to which carboxylic or amino groups are chemically linked, as well as gangliosides, such as ganglioside GM1. Copolymers of PEG, methoxy PEG, or methoxy PPG, or derivatives thereof, are also suitable. In addition, the opsonization inhibiting polymer can be a block copolymer of PEG and either a polyamino acid, polysaccharide, polyamidoamine, polyethyleamine, or polynucleotide. The opsonization inhibiting polymers can also be natural polysaccharides containing amino acids or carboxylic acids, e.g., galacturonic acid, glucuronic acid, mannuronic acid, hyaluronic acid, pectic acid, neuraminic acid, alginic acid, carrageenan;

laminated polysaccharides or oligosaccharides (linear or branched); or carboxylated polysaccharides or oligosaccharides, e.g., reacted with derivatives of carbonic acids with resultant linking of carboxylic groups. Preferably, the opsonization-inhibiting moiety is a PEG, PPG, or derivatives thereof. Liposomes modified with PEG or PEG-derivatives are sometimes called "PEGylated liposomes." The opsonization inhibiting moiety can be bound to the liposome membrane by any one of numerous well-known techniques. For example, an N-hydroxysuccinimide ester of PEG can be bound to a phosphatidyl-ethanolamine lipid-soluble anchor, and then bound to a membrane. Similarly, a dextran polymer can be derivatized with a stearylamine lipid-soluble anchor via reductive amination using Na(CN)BH<sub>3</sub> and a solvent mixture such as tetrahydrofuran and water in a 30:12 ratio at 60°C.

[0179] The above-recited microparticles and liposomes and methods of preparing microparticles and liposomes are offered by way of example and are not intended to define the scope of microparticles or liposomes of use in the present invention. It will be apparent to those of skill in the art that an array of microparticles or liposomes, fabricated by different methods, are of use in the present invention.

[0180] In another embodiment of the present invention, the methods of the invention include the use of two or more populations of RNAi agents. The populations are distinguished by, for example, sequence, or by having different rates of release from a carrier, coating, or matrix of the invention. Two or more different rates of release can be obtained by, for example, incorporating one RNAi agent population into the bulk coating and another RNAi agent population into microcapsules embedded in the bulk coating. In another exemplary embodiment, the two RNAi or more agents are encapsulated in microspheres having distinct release properties. For example, a first agent is encapsulated in a liposome and a second RNAi agent is encapsulated in an alginate microsphere.

[0181] Other characteristics of the RNAi agent populations in addition to their release rates can be varied as well. For example, the two RNAi agent populations can consist of agents having the same or different sequences, and the sequences can target different portions of the same gene, or portions of different genes. Also,

one or more RNAi agents can be delivered as siRNAs, and other RNAi agents can be delivered as ddRNAs. The concentrations of the two or more RNAi populations can differ from one another. For example, in certain applications it is desirable to have one agent released rapidly (e.g., an RNAi agent targeting a gene involved in blood clotting) at a first concentration, while a second RNAi agent is released more slowly at a second concentration (e.g., an inhibitor of tissue overgrowth). Furthermore when two or more distinct RNAi agents are used they can be distributed at two or more unique sites within the delivery vehicle.

[0182] In certain embodiments, a solid, flexible therapeutic is formed by dispensing a flowable polymer, or polymer precursor, formulation onto the surface of a matrix. The formulation can be applied by any convenient technique. For example, the formulation can be applied by brushing, spraying, extruding, dripping, injecting, or painting. Spraying, via aerosolization is a preferred method of administration because it minimizes the amount of formulation applied to the site of insult while maximizing uniformity. A thin, substantially uniform matrix, such as that formed by spraying, can also be called a film. Typically, the film has a thickness of about 10  $\mu\text{m}$  to about 10 mm, more preferably from about 20  $\mu\text{m}$  to about 5 mm. Spraying is a preferred method for applying the polymer formulation to a large surface area. In contrast, dripping may be preferred for applying the polymer formulation to a small surface area.

[0183] Characterization of the RNAi agent, the carriers, coating, and matrices and the combination thereof can be performed at different loadings of RNAi agent to investigate nucleic acid formulation, and carrier, coating, and matrix formulation and encapsulation properties and morphological characteristics. Microparticle size can be measured by quasi-elastic light scattering (QELS), size-exclusion chromatography (SEC) and the like. Drug loading can be measured by dissolving the coating or the microparticles into an appropriate solvent and assaying the amount of biologically active molecules using one or more art-recognized techniques. Useful techniques include, for example, spectroscopy (e.g., IR, NMR, UV/Vis, fluorescence, etc.), mass spectrometry, elemental analysis, HPLC, HPLC coupled with one or more spectroscopic modalities, and other



appropriate means.

[0184] Delivery of RNAi Agents

[0185] The RNAi expression constructs or siRNA agents of the present invention may be introduced into the target cells *in vitro* or *ex vivo* and then subsequently placed into a patient to affect therapy, or administered directly to a patient by *in vivo* administration.

[0186] The most common transfection reagents are charged lipophilic compounds that are capable of crossing cell membranes. When these are complexed with an RNAi agent they can act to carry the RNAi agent across the cell membrane. A large number of such compounds are available commercially. Polyethylenimine (PEI) is a class of transfection reagents, chemically distinct from lipophilic compounds, that act in a similar fashion to lipophilic compounds, but have the advantage they can also cross nuclear membranes. An example of such a reagent is ExGen 500 (Fermentas). A construct or synthetic gene according to the present invention may be packaged as a linear fragment within a synthetic liposome or micelle for delivery into the target cell.

[0187] Compositions may also be injected by microinjection or intramuscular jet injection (for example as described by Furth et al., Anal. Biochem., 205: 265-368, (1992)). Another route of administration is hydrodynamic in which an aqueous formulation of the naked genetic construct, agent or synthetic gene is prepared, usually with a DNase inhibitor, and administered to the vascular system of the patient.

[0188] The techniques for delivery of DNA and RNA constructs to animal cells described in U.S. Patent Nos. 5,985,847 and 5,922,687 are also applicable. The entire contents of these two specifications are incorporated herein by reference.

[0189] The RNAi agents of the present invention may also be delivered transdermally using a range of patch, spray, iontophoretic or poration based methodologies. Iontophoresis is predicated on the ability of an electric current to

cause charged particles to move. A pair of adjacent electrodes placed on the skin set up an electrical potential between the skin and the capillaries below. At the positive electrode, positively charged drug molecules are driven away from the skin's surface toward the capillaries. Conversely, negatively charged drug molecules would be forced through the skin at the negative electrode. Because the current can be literally switched on and off and modified, iontophoretic delivery enables rapid onset and offset, and drug delivery is highly controllable and programmable.

[0190] Poration technologies, use high-frequency pulses of energy, in a variety of forms (such as radio frequency radiation, laser, heat or sound) to temporarily disrupt the stratum corneum. It is important to note that unlike iontophoresis, the energy used in poration technologies is not used to transport the drug across the skin, but facilitates its movement. Poration provides a "window" through which drug substances can pass much more readily and rapidly than they would normally.

[0191] The RNAi agents described herein may be co-administered with one or more other compounds or molecules or administered in conjunction with another treatment modality. By "co-administered" is meant simultaneous administration in the same formulation or in two different formulations via the same or different routes or sequential administration by the same or different routes. By "sequential" administration is meant a time difference of from seconds, minutes, hours or days between the administration of the two types of molecules. These molecules may be administered in any order. More particularly the present invention contemplates co-administration of a genetic construct in accordance with the present invention with one or more known psoriasis treatments including tar-based treatments; UV-light based treatments including sunlight, UVB treatment, UVA treatment and PUVA treatment; Cortisone; Calcipotriol; Methotrexate; Tigason; Cyclosporin and the like.

[0192] While the present invention has been described with reference to specific embodiments, it should be understood by those skilled in the art that various changes may be made and equivalents may be substituted without departing from the true spirit and scope of the invention. In addition, many modifications may be

made to adapt a particular situation, material or process to the objective, spirit and scope of the present invention. All such modifications are intended to be within the scope of the invention.

[0193] All references cited herein are to aid in the understanding of the invention, and are incorporated in their entireties for all purposes without limitation.

**WHAT IS CLAIMED IS:**

1. A method for treating or preventing psoriasis, said method comprising administering a first RNAi agent to a subject, wherein the first RNAi agent downregulates or silences one or more transcriptionally active genetic regions that are directly or indirectly associated with the onset, development, maintenance, or progression of psoriasis.
2. The method of claim 1, wherein the first RNAi agent comprises a nucleotide sequence that is at least 70% identical to at least a part of a nucleotide sequence comprising a psoriasis associated genetic target.
3. The method of claim 1, wherein the first RNAi agent is a ddRNAi agent.
4. The method of claim 1, wherein the first RNAi agent is formulated with a compress or bandage and is administered to the subject with the compress or bandage.
5. The method of claim 1, wherein the first RNAi agent is reversibly associated with a carrier, coating, or matrix.
6. The method of claim 1, wherein the first RNAi agent is covalently attached to a carrier or coating.
7. The method of claim 1, wherein the first RNAi agent is administered to the subject by a viral delivery system.
8. The method of claim 1, wherein the first RNAi agent downregulates or silences a first transcriptionally active genetic region that is directly or indirectly associated with the onset, development, maintenance, or progression of psoriasis, and further comprising administering to the subject a second RNAi agent that downregulates or silences a second transcriptionally active genetic region that is

directly or indirectly associated with the onset, development, maintenance, or progression of psoriasis.

9. A genetically modified cell comprising a ddRNAi expression cassette that expresses a ddRNAi agent that downregulates or silences one or more transcriptionally active genetic regions that are directly or indirectly associated with the onset, development, maintenance, or progression of psoriasis.

10. A therapeutic device comprising an RNAi agent that downregulates or silences one or more transcriptionally active genetic regions that are directly or indirectly associated with the onset, development, maintenance, or progression of psoriasis and a carrier.

1/7

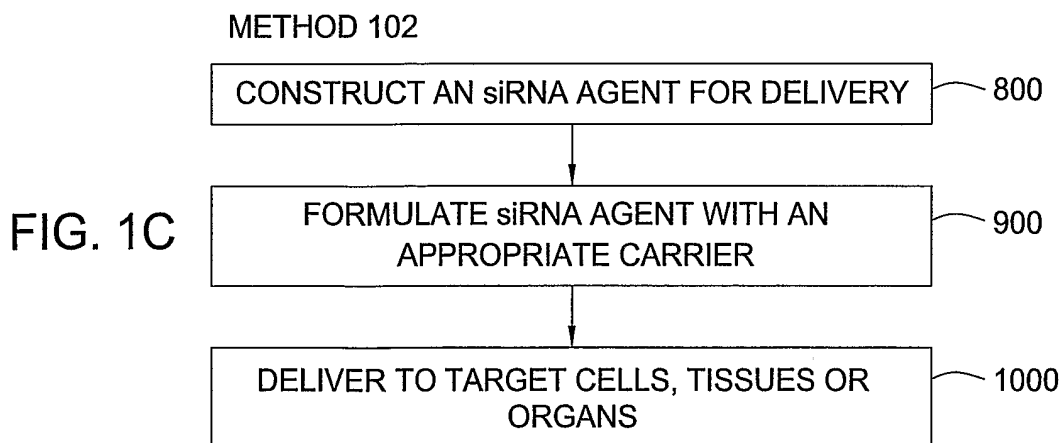
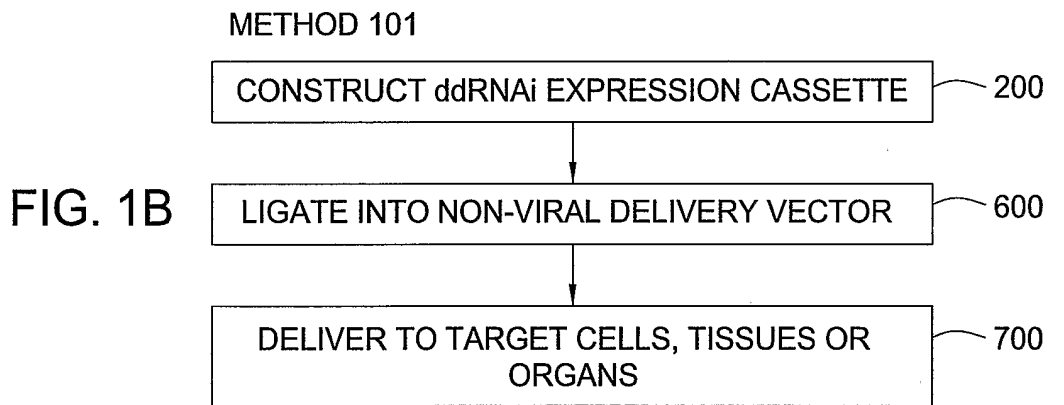
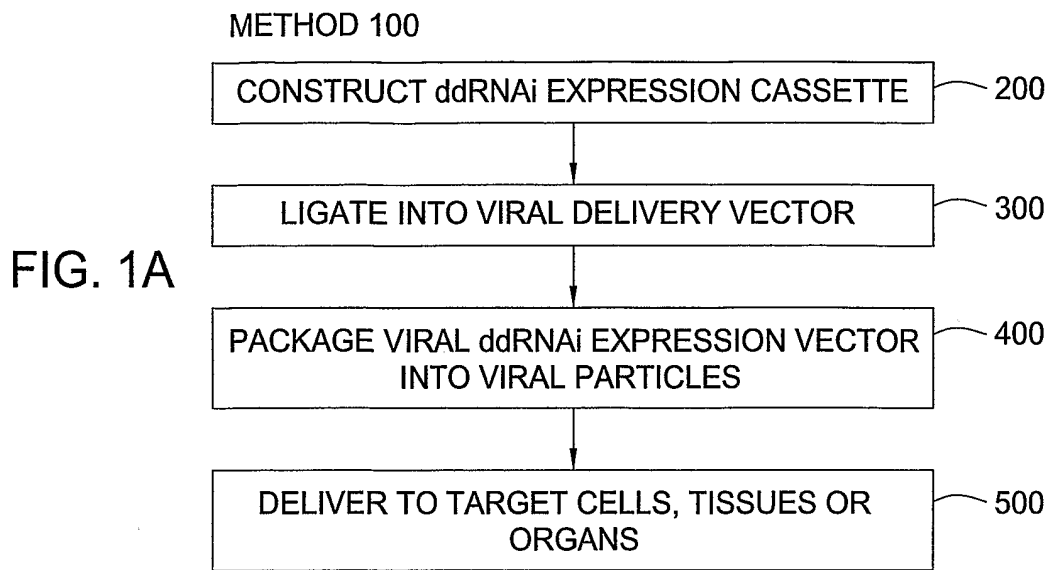

FIG. 2A

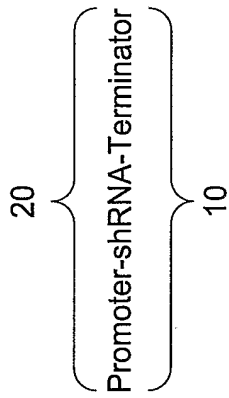

FIG. 2B

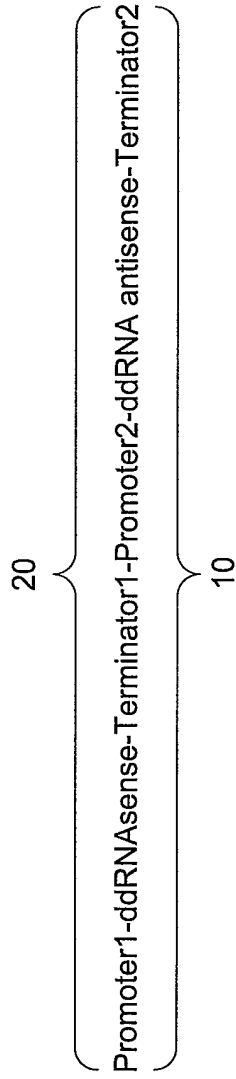

FIG. 2C

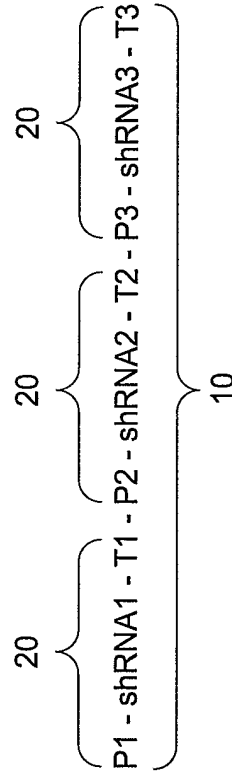
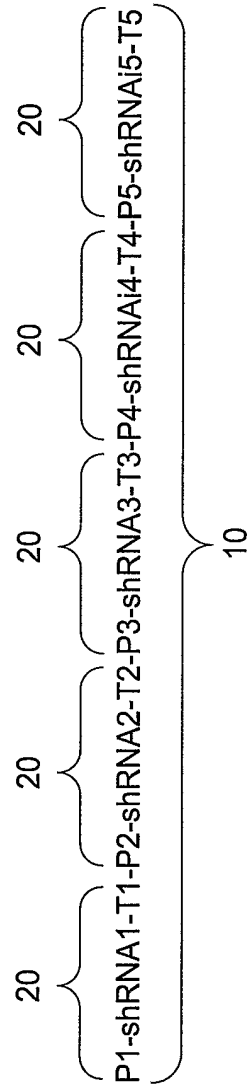

FIG. 2D



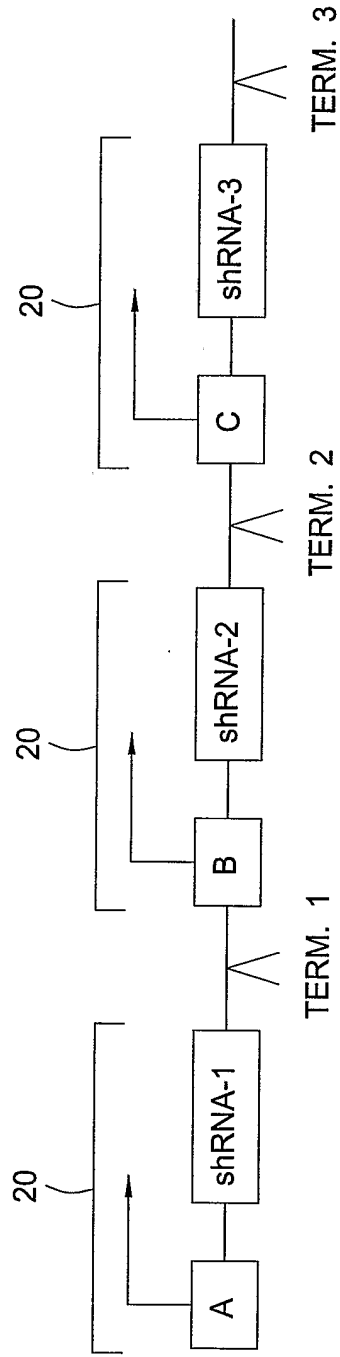

FIG. 3A

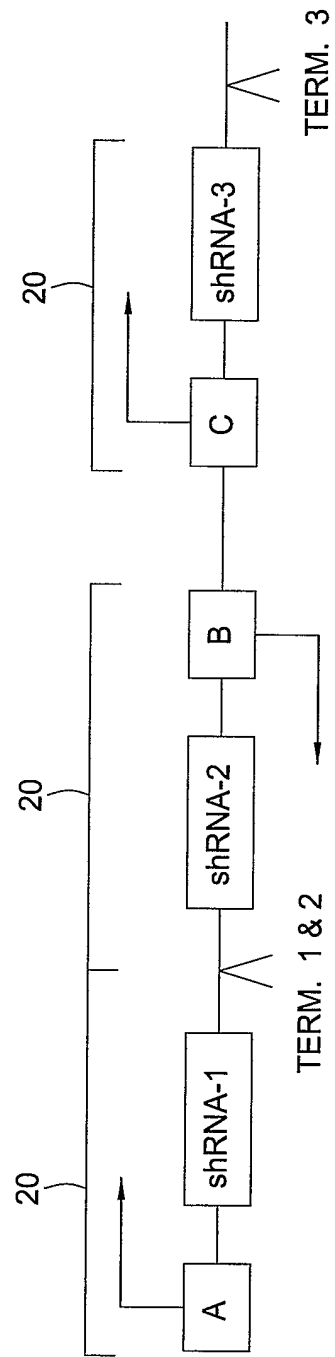

FIG. 3B



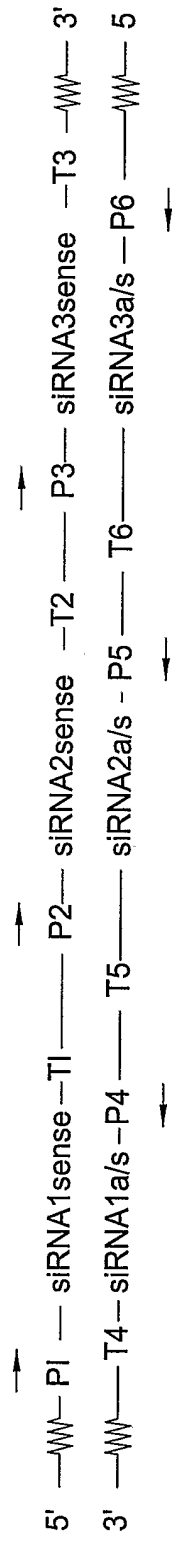

FIG. 3C

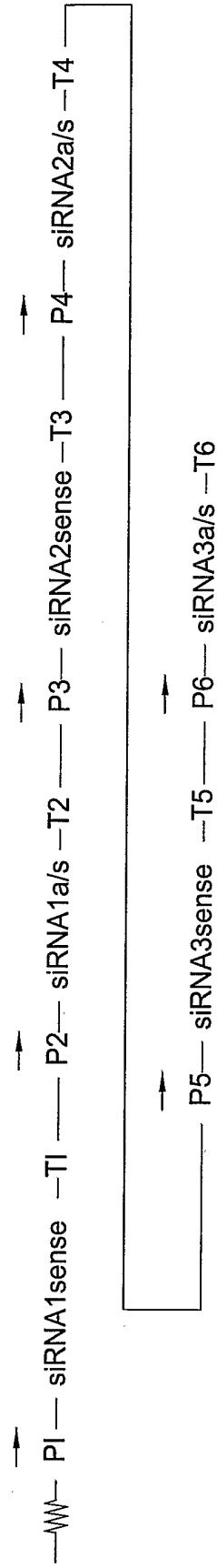

FIG. 3D

5/7

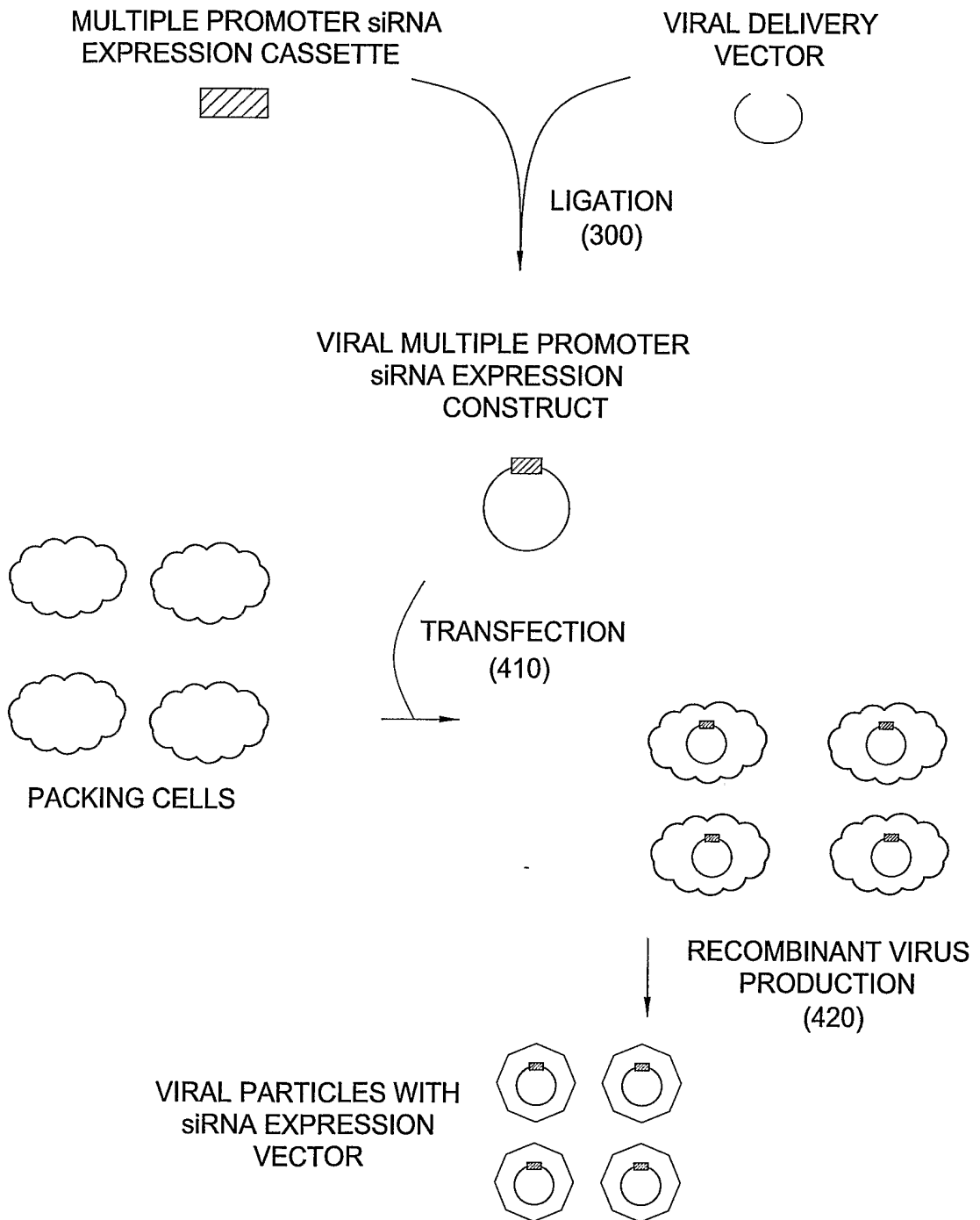
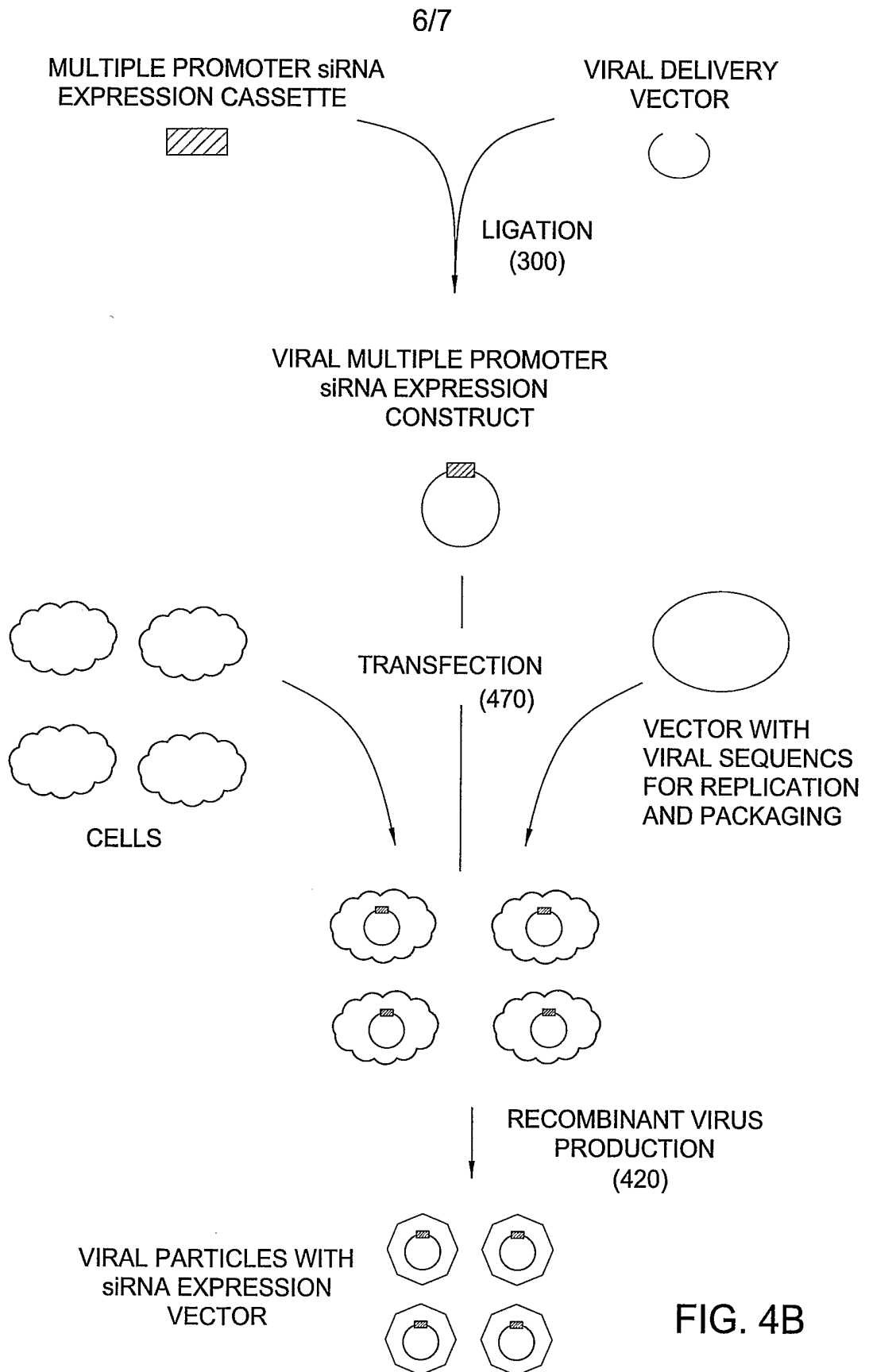

FIG. 4A



7/7

## FIG. 5

GENE	ASSESSION No.	GENE	ASSESSION No.
DEPB2	Z71389	SCCA1	S66996
SCCA2	U19667	KRT6E	L42611
P13	L10343	PP13	M80254
KRT16	S72493	PKP1	Z34974
S100A7	M65757	EIFSA	U17969
KAT17	Z19574	HSPA8	HG2855-HT2995
CRABP2	M97815	COPB	X70476
FABP6	M94856	K201 HSP105	D86958
TCN1	J05068	CTSB	HG417-HT417
ATP1AL1	L42563	LDLR	L00352
CD24	L33930	CAP2	L40377
LGALS3BP	L13210	ELP1	M88458
DSG3	M76482	EIF5	U49436
ATP1B1	US6799	GARS	U09587
ATP2A2	M23114	UBE2N	D83004
K238 PERML1	D67075	RCH1	U28386
PLSCR1	AF00S445	CTSL	X12451
TETAL	L11660	CASP4	U28014
CD2	M18336	PHB	S85655
THBD	J02973	EIF2A	J02645
MTX	J03080	CSTB	U46692
TUBG	M61764	PSMA28	D45248
TUBB2	HG4322-HT4692	PSMB10	X71874
M2AZ	M37583	HSN	U03057
DDX	U90426	HSPE1	U07550
IF156	M24694	SF2P32	M69039
UP	X90858	EIF2B	M29536
CD47	Z26621	LAD1	U42408
IRAK1	L75191	SEC23B	X97085
BENE	U17077	MACS	D10522
IF127SEP	J04164	TB3 1	M75716
IL4R	X52425	UBE21	U45328
SCYA2	HG4089-HT4339	PKM2	X58494
MMP12	L23808	CLARP	AF005775
GJB2	MS6849	SOD2	X65965
HNL	S75256	HMOX1	X06985
CHIT1	U49835	ATOX1	U70660
PRSS6	L33404	MX1	M33882
PRSS3	X71346	HBP17	M60047
MAL	D16626	GNA1S	M63904
LKYMYD	US7721	3PK	U09578
ARG1	X12662	PTPCAAX1	U48296
SOLE	D78128	PPP2CA	M60483
ARP	M83751	ACPP	M24902
FGD	U30255	CESPD	M83667
GOT2	M22632	PRKMK3	D87116
SRM	M34338	PRTK	U02680
BRCAME	U43944	SPRR2A	M21302
PCBD	D17400	TGM3	L10386
GOT1	M37400	TGM1	M98447
PGAM1	J04173	SPRR1B	M19888
PCMT1	D25547	SOP2PL	Y08999
AMD1	M21154	KPNB1	L38951
POB	S90459	S100A9	M26311
PON2	L48513	S10DA12	D83657
ANT2	J02883	S100A2	Y07755
GSTP1	M24486	S100A11	D38583
GSK3A	L40027	CDC25	S78187
UOCRFS1	L32977	CCNF	Z36714
STAT1	M97936	TOP1	U07806
IFNRG7A	US3830	K5	D13630
ID1	HG3342-HT3619	NP	K20574
RANBP1	D38076	K111 NUK34	D21853
PCSK4	HG4297-HT4567	E 23840	U79267
ETR101	M62831	K101	D14657
HF1A	U22431	E 23773	U90904
ZFP36	M92843	SULT2B1A	U92314
MOF1	U78313	TB1	M74089
NF116	MG3494-HT3688	K98 TCP1	D43950
TAF2H	UT3991	LIV1	U41060
C8FB	L20298		
EFWLL2	UBB629		

# INTERNATIONAL SEARCH REPORT

International application No  
PCT/US2005/038139

<b>A. CLASSIFICATION OF SUBJECT MATTER</b> C12N15/11      A61K48/00      C12N5/10				
According to International Patent Classification (IPC) or to both national classification and IPC				
<b>B. FIELDS SEARCHED</b>				
Minimum documentation searched (classification system followed by classification symbols) C12N    A61K				
Documentation searched other than minimum documentation to the extent that such documents are included in the fields searched				
Electronic data base consulted during the international search (name of data base and, where practical, search terms used)  EPO-Internal, WPI Data, BIOSIS				
<b>C. DOCUMENTS CONSIDERED TO BE RELEVANT</b>				
Category*	Citation of document, with indication, where appropriate, of the relevant passages	Relevant to claim No.		
X	WO 02/096927 A (RIBOZYME PHARMACEUTICALS, INCORPORATED; CHIRON CORPORATION; ESCOBEDO,) 5 December 2002 (2002-12-05) page 8, line 3 - page 11, line 18 page 29, line 33 - page 30, line 17 page 50, line 13 - page 52, line 13 page 76, line 28 - page 77, line 10 -----	1-10		
X	US 2003/157030 A1 (DAVIS MARK E ET AL) 21 August 2003 (2003-08-21) paragraphs '0005!, '0006!, '0023! - '0029!, '0091!, '0115! - '0117!, '0139! - '0173!, '0209! - '0217!, '0251!; claims 64,72; figure 1 ----- -/--	1-10		
<table style="width: 100%; border: none;"> <tr> <td style="width: 50%; border: none;"><input checked="" type="checkbox"/> Further documents are listed in the continuation of Box C.</td> <td style="width: 50%; border: none;"><input checked="" type="checkbox"/> See patent family annex.</td> </tr> </table>			<input checked="" type="checkbox"/> Further documents are listed in the continuation of Box C.	<input checked="" type="checkbox"/> See patent family annex.
<input checked="" type="checkbox"/> Further documents are listed in the continuation of Box C.	<input checked="" type="checkbox"/> See patent family annex.			
* Special categories of cited documents :				
'A' document defining the general state of the art which is not considered to be of particular relevance 'E' earlier document but published on or after the international filing date 'L' document which may throw doubts on priority claim(s) or which is cited to establish the publication date of another citation or other special reason (as specified) 'O' document referring to an oral disclosure, use, exhibition or other means 'P' document published prior to the international filing date but later than the priority date claimed	'T' later document published after the international filing date or priority date and not in conflict with the application but cited to understand the principle or theory underlying the invention 'X' document of particular relevance; the claimed invention cannot be considered novel or cannot be considered to involve an inventive step when the document is taken alone 'Y' document of particular relevance; the claimed invention cannot be considered to involve an inventive step when the document is combined with one or more other such documents, such combination being obvious to a person skilled in the art. '&' document member of the same patent family			
Date of the actual completion of the international search		Date of mailing of the international search report		
28 February 2006		14/03/2006		
Name and mailing address of the ISA/ European Patent Office, P.B. 5818 Patentlaan 2 NL - 2280 HV Rijswijk Tel. (+31-70) 340-2040, Tx. 31 651 epo nl, Fax: (+31-70) 340-3016		Authorized officer  Ferreira, R		

## INTERNATIONAL SEARCH REPORT

International application No

IS2005/038139

C(Continuation). DOCUMENTS CONSIDERED TO BE RELEVANT

Category*	Citation of document, with indication, where appropriate, of the relevant passages	Relevant to claim No.
X	WO 2004/043408 A (GENPATH PHARMACEUTICALS, INCORPORATED; O'HAGAN, RONAN, C; KANNAN, KARU) 27 May 2004 (2004-05-27) page 5, line 20 - line 30 page 29, line 21 - line 28 page 31, line 5 - page 33, line 34 page 37, line 6 - page 39, line 17 claims 16,21,40,90 example 6	1-10
X	----- US 2004/018176 A1 (TOLENTINO MICHAEL J ET AL) 29 January 2004 (2004-01-29) paragraphs '0009! - '0029!, '0052! - '0065!, '0083! - '0092!; claims 43,44; example 7	1-10
X	----- US 2004/209832 A1 (MCSWIGGEN JAMES ET AL) 21 October 2004 (2004-10-21) paragraphs '0011!, '0123!, '0196!, '0199!, '0214!, '0271! - '0273!, '0278!, '0320! - '0326!, '0335!, '0336!; claims 3,11; figures 7-9	1-10
A	----- WO 2004/076664 A (UNIVERSITY OF SOUTH FLORIDA; MOHAPATRA, SHYAM, S; ZHANG, WEIDONG) 10 September 2004 (2004-09-10) abstract page 11, line 13 - line 25; figure 1 claims 25,26	1-3,8
A	----- BONIFATI C ET AL: "Cytokines in psoriasis." INTERNATIONAL JOURNAL OF DERMATOLOGY. APR 1999, vol. 38, no. 4, April 1999 (1999-04), pages 241-251, XP002365892 ISSN: 0011-9059 the whole document	1

# INTERNATIONAL SEARCH REPORT

International application No.  
PCT/US2005/038139

## Box II Observations where certain claims were found unsearchable (Continuation of item 2 of first sheet)

This International Search Report has not been established in respect of certain claims under Article 17(2)(a) for the following reasons:

1.  Claims Nos.:  
because they relate to subject matter not required to be searched by this Authority, namely:  
  
Although claims 1-8 are directed to a method of treatment of the human/animal body, the search has been carried out and based on the alleged effects of the compound/composition.
2.  Claims Nos.:  
because they relate to parts of the International Application that do not comply with the prescribed requirements to such an extent that no meaningful International Search can be carried out, specifically:
3.  Claims Nos.:  
because they are dependent claims and are not drafted in accordance with the second and third sentences of Rule 6.4(a).

## Box III Observations where unity of invention is lacking (Continuation of item 3 of first sheet)

This International Searching Authority found multiple inventions in this international application, as follows:

1.  As all required additional search fees were timely paid by the applicant, this International Search Report covers all searchable claims.
2.  As all searchable claims could be searched without effort justifying an additional fee, this Authority did not invite payment of any additional fee.
3.  As only some of the required additional search fees were timely paid by the applicant, this International Search Report covers only those claims for which fees were paid, specifically claims Nos.:
4.  No required additional search fees were timely paid by the applicant. Consequently, this International Search Report is restricted to the invention first mentioned in the claims; it is covered by claims Nos.:

### Remark on Protest

- The additional search fees were accompanied by the applicant's protest.
- No protest accompanied the payment of additional search fees.

## INTERNATIONAL SEARCH REPORT

 International application No  
 .../US2005/038139

Patent document cited in search report		Publication date	Patent family member(s)	Publication date
WO 02096927	A	05-12-2002	CA 2448320 A1 EP 1390385 A2 JP 2005500025 T	05-12-2002 25-02-2004 06-01-2005
US 2003157030	A1	21-08-2003	AU 2002368202 A1 CA 2465860 A1 EP 1575976 A2 JP 2005527639 T WO 2004033620 A2	04-05-2004 22-04-2004 21-09-2005 15-09-2005 22-04-2004
WO 2004043408	A	27-05-2004	AU 2003295604 A1	03-06-2004
US 2004018176	A1	29-01-2004	AU 2003253995 A1 CA 2493499 A1 EP 1578933 A2 MX PA05001000 A WO 2004009769 A2	09-02-2004 29-01-2004 28-09-2005 16-05-2005 29-01-2004
US 2004209832	A1	21-10-2004	US 2004198682 A1	07-10-2004
WO 2004076664	A	10-09-2004	NONE	