

No. 817,687.

PATENTED APR. 10, 1906.

D. BACON.
MAGNETIC ACTUATOR.
APPLICATION FILED AUG. 24, 1904.

2 SHEETS—SHEET 1.

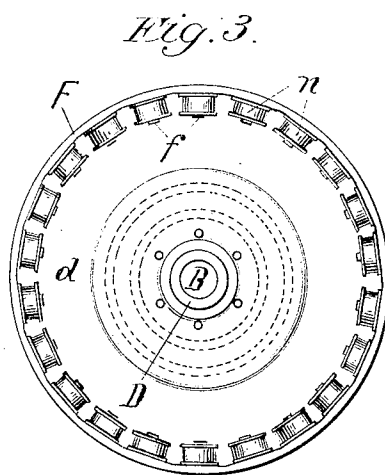
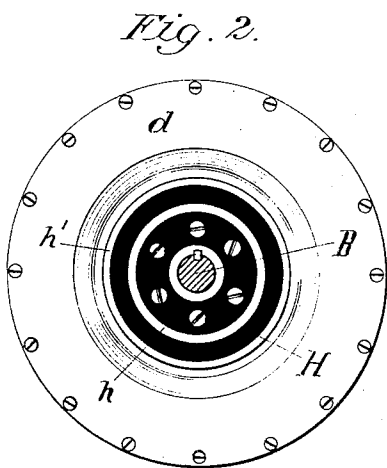
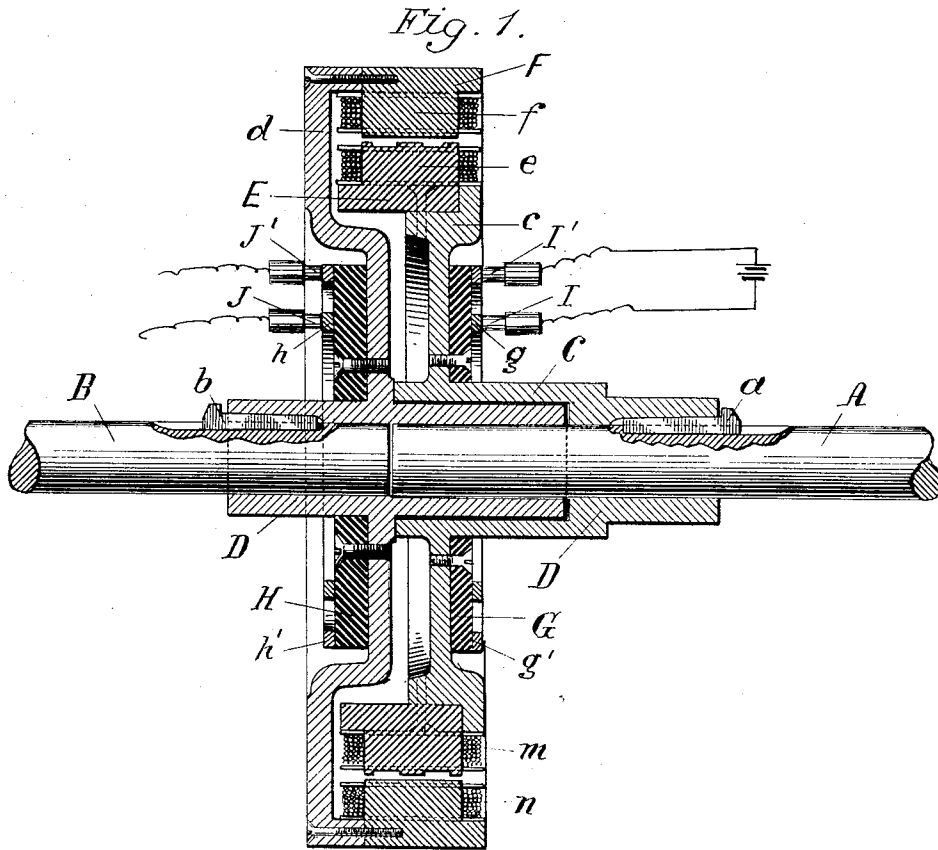

Witnesses
Edward Rowland
A. P. Elton

Inventor
Daniel Bacon
By his Attorney
F. W. Huber

No. 817,687.

PATENTED APR. 10, 1906.

D. BACON.
MAGNETIC ACTUATOR.
APPLICATION FILED AUG. 24, 1904.

2 SHEETS—SHEET 2.

Fig. 4.

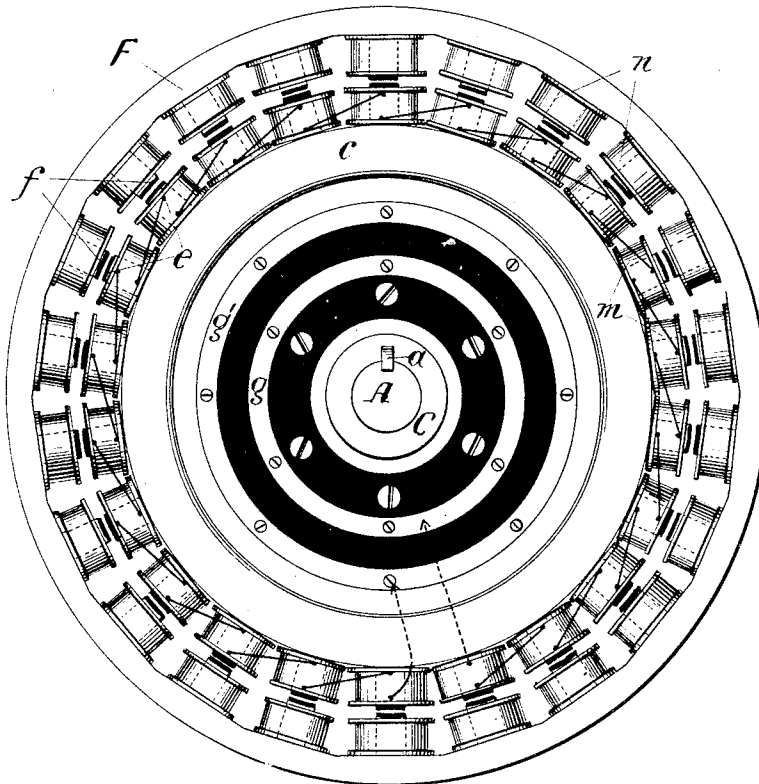
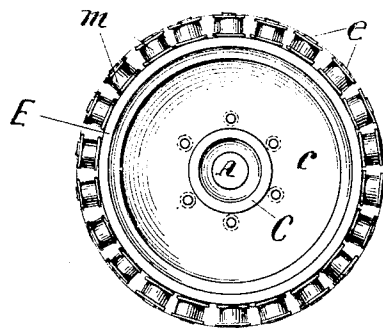

Fig. 5.



Witnesses
Edward Rowland,
A. P. Elton

Inventor
Daniel Bacon
By his Attorney
F. W. Parker

UNITED STATES PATENT OFFICE.

DANIEL BACON, OF BROOKLYN, NEW YORK, ASSIGNOR TO MAGNETIC CONTROL COMPANY, OF NEW YORK, N. Y., A CORPORATION OF NEW YORK.

MAGNETIC ACTUATOR.

No. 817,687.

Specification of Letters Patent.

Patented April 10, 1906.

Application filed August 24, 1904. Serial No. 221,910.

To all whom it may concern:

Be it known that I, DANIEL BACON, a citizen of the United States, residing in the borough of Brooklyn, in the county of Queens and State of New York, have invented a new and useful Improvement in Magnetic Actuators, of which the following is a specification.

This invention relates to magnetic actuators; and it has for its object the provision of an electromagnetic coefficient for mechanical power transmission.

In apparatus of this nature it is frequently essential that its operation may be controlled from a distance, or, in other words, that it should be possible and practicable to make connection electromagnetically between a driving shaft or apparatus and a driven one for the purpose of transmitting motive power to the driven part and to break such connection, thereby bringing the driven part to a stop at will and from whatever position or distance such may be desired in a simple and effective manner. Furthermore, it is desirable that such transmission of power may take place gradually, without jerks and jolts, and with a minimum of wear of the actuating parts. I accomplish these objects with the apparatus hereinafter described, and particularly pointed out in the claim which follows this specification.

Referring to the drawings, in which like letters of reference represent like parts wherever used, and which form part of this specification, Figure 1 is a vertical central sectional view of my improved magnetic actuator. Fig. 2 is a reduced side view of the same, looking from the left toward Fig. 1. Fig. 3 is a similar side view looking from the right toward Fig. 1, but omitting shaft A and electromagnet E. Fig. 4 is a side view of electromagnet E, looking from the left toward Fig. 1; and Fig. 5 is a side view of the complete device, on the same scale and looking from the right toward Fig. 1.

In the form of my invention illustrated in the drawings, A indicates a power or driving shaft, which may derive its impelling energy from any source, while B represents the driven shaft to which power is to be transmitted or conveyed by an electromagnetic connection to be established between these two shafts. Mounted upon the shaft A and rigidly secured thereto, as by a spline or key a , is a sleeve C, having a web c . Mounted upon the shaft B and rigidly secured thereto, as by a spline or key b , is a sleeve D, having a

web d . The shaft A is arranged to extend into the sleeve D, within which it is free to rotate, and the sleeve D to extend into the sleeve C, being sufficiently free therein to assure concentricity of the two shafts at all times without undue friction. Rigidly secured to web c is an annulus E, preferably formed of magnetizable material possessing a high degree of permeability to reduce residual magnetism to a minimum. This annulus E is provided at its periphery with a series of radial projections e , over which wire-spools m may be slipped or otherwise secured thereto. In this manner a multipolar electromagnet is provided, the annular part forming the yoke and the outwardly-projecting magnet cores or shanks e being arranged in a plane at right angles to the shaft A and equidistant from one another.

To the periphery of the web d is secured an annulus F, which is also provided with radially-disposed projections f , equal in number to the number of the projections or cores e on annulus E. These magnet-cores f project inwardly and are arranged in a plane at right angles to the shaft B, forming, in conjunction with annulus F and the wire spools or coils n , a powerful multipolar electromagnet.

The two multipolar electromagnets mounted on the shafts A and B relatively to one another in such a manner that their cores e and f are at all times in the same plane, with their pole-faces opposite and curved to correspond to the arc of the circle they describe by their rotation and in as close but non-contacting proximity as practicable to reduce the unavoidable air-gap to a minimum.

The wire coils may be connected in series or in multiple, as desired. Placed against the web c is a disk G, of insulating material, bearing a pair of collecting-rings $g g'$, and a similar disk H, of insulating material, is placed against the web d , this disk H bearing the collecting-rings $h h'$. Brushes I I' and J J' bear, respectively, against the collector-rings $g g'$ and $h h'$, conveying current thereto from a suitable source of electrical energy. However, the two multipolar electromagnets may be fed from different sources of electricity. The wire coils m and n are placed on their respective cores in such a manner that the polarity at the pole-faces of the same is alternately north and south, thus requiring an even number of polar projections for both electromagnets.

In the operation of my invention when the

two multipolar electromagnets E and F are in a quiescent state—that is, when not being energized—then the power or driving shaft A with its sleeve C and web *c* and electromagnet 5 E, is free to rotate without transmitting movement or power to the shaft B, with sleeve D, web *d*, and electromagnet F, and in this condition a machine to be actuated by said shaft B remains inactive, since the two 10 electromagnets E and F cannot influence one another; but when it is desired to start up a machine whose moving parts are connected with or operated by the shaft B then the coils *m* and *n* of the electromagnets E and F are 15 inserted in an electric circuit comprising a source of electricity, whereupon the magnetic flux set up in the cores and by the arrangement of the polarity of the pole-faces of the magnet-cores made to pass across the air-gaps formed by the oppositely-placed said 20 pole-faces, provided the opposing pole-faces are of different signs of polarity, will effect a magnetic union between the two electromagnets, thereby enabling motive power to be 25 communicated from shaft A to shaft B to rotate the latter. However, I do not wish to confine myself to the manner of connecting the wire coils to obtain in each electromagnet alternating polarity for adjacent pole-faces, as described; but I may arrange the 30 connections in such a way that all the pole-faces of one electromagnet are south and those of the other electromagnet are all north. By such an arrangement the webs *c* and *d*, sleeves C and D, and the ends of the 35 shafts A and B may be included in the magnetic circuit.

While in the drawings I have represented the core-surfaces or pole-faces as separated from each other by relatively considerable 40 spaces, this is merely for the purpose of clearly indicating their non-contacting relation.

It is the purpose in employing my invention to use a very light current, the improvement being chiefly applicable for governing 45 purposes, and I do not intend to employ it where there is the liability of a counter-generated current equaling the current made use of. It is also my intention to provide for a 50 variation in the speed transmitted from the driving portion of the apparatus to the driven portion, and this effect I produce by introducing a resistance in the electric circuit, this feature being so obvious as to re- 55 quire no illustration.

Having now described my invention, I declare that what I claim is—

A magnetic actuator comprising a driving-shaft and a driven shaft, said shafts having 60 telescoping concentric sleeves capable of independent rotation, together with a radial web extending from each of said sleeves and a plurality of electromagnets supported at the periphery of each of said radial webs, the 65 pole-faces of the magnets upon each periphery being in non-contacting magnetic relation, an electric circuit and means for energizing it.

DANIEL BACON.

Witnesses:

FREDERICK C. BONNY,
F. W. BARKER.