



(51) International Patent Classification:

A61K 8/73 (2006.01) A61K 9/16 (2006.01)
A61K 8/19 (2006.01) A61Q 19/00 (2006.01)

(21) International Application Number:

PCT/US2016/054328

(22) International Filing Date:

29 September 2016 (29.09.2016)

(25) Filing Language:

English

(26) Publication Language:

English

(30) Priority Data:

62/234,209 29 September 2015 (29.09.2015) US
15/279,626 29 September 2016 (29.09.2016) US

(71) Applicant: JOHNSON & JOHNSON CONSUMER

INC. [US/US]; 199 Grandview Road, Skillman, New Jersey 08558 (US).

(72) Inventors: BONNER, Patricia; 199 Grandview Road,

Skillman, New Jersey 08558 (US). HERNANDEZ, Amanda; 755 Estates Boulevard, Apt. 279, Mercerville, New Jersey 08619 (US). MAITRA, Prithwiraj; 199 Grandview Road, Skillman, New Jersey 08558 (US). PATEL, Jiger J.; 199 Grandview Road, Skillman, New Jersey 08558 (US).

sey 08558 (US). PATEL, Meenskahi Lalit; 290 Echelon Road, Apt. 8, Voorhees, New Jersey 08043 (US).

(74) Agents: SHIRTZ, Joseph, F. et al.; Johnson & Johnson, One Johnson & Johnson Plaza, New Brunswick, New Jersey 08933 (US).

(81) Designated States (unless otherwise indicated, for every kind of national protection available): AE, AG, AL, AM, AO, AT, AU, AZ, BA, BB, BG, BH, BN, BR, BW, BY, BZ, CA, CH, CL, CN, CO, CR, CU, CZ, DE, DJ, DK, DM, DO, DZ, EC, EE, EG, ES, FI, GB, GD, GE, GH, GM, GT, HN, HR, HU, ID, IL, IN, IR, IS, JP, KE, KG, KN, KP, KR, KW, KZ, LA, LC, LK, LR, LS, LU, LY, MA, MD, ME, MG, MK, MN, MW, MX, MY, MZ, NA, NG, NI, NO, NZ, OM, PA, PE, PG, PH, PL, PT, QA, RO, RS, RU, RW, SA, SC, SD, SE, SG, SK, SL, SM, ST, SV, SY, TH, TJ, TM, TN, TR, TT, TZ, UA, UG, US, UZ, VC, VN, ZA, ZM, ZW.

(84) Designated States (unless otherwise indicated, for every kind of regional protection available): ARIPO (BW, GH, GM, KE, LR, LS, MW, MZ, NA, RW, SD, SL, ST, SZ, TZ, UG, ZM, ZW), Eurasian (AM, AZ, BY, KG, KZ, RU, TJ, TM), European (AL, AT, BE, BG, CH, CY, CZ, DE, DK, EE, ES, FI, FR, GB, GR, HR, HU, IE, IS, IT, LT, LU, LV, MC, MK, MT, NL, NO, PL, PT, RO, RS, SE, SI, SK,

[Continued on next page]

(54) Title: COMPOSITION FOR DUST PARTICLE REDUCTION

(57) Abstract: Combination powdered material, including a first powder composition and a second powder composition, the first powder composition including cellulose particulate material and the second powder composition including starch particles, alone or in combination with talc particles.

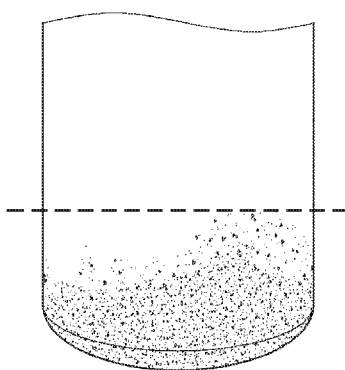

FIG. 5



SM, TR), OAPI (BF, BJ, CF, CG, CI, CM, GA, GN, GQ, GW, KM, ML, MR, NE, SN, TD, TG).

Published:

Declarations under Rule 4.17:

- *as to applicant's entitlement to apply for and be granted a patent (Rule 4.17(ii))*
- *as to the applicant's entitlement to claim the priority of the earlier application (Rule 4.17(iii))*

- *with international search report (Art. 21(3))*
- *before the expiration of the time limit for amending the claims and to be republished in the event of receipt of amendments (Rule 48.2(h))*

COMPOSITION FOR DUST PARTICLE REDUCTIONField of the Invention

[0001] The present invention relates to materials and compositions suitable for reducing the release of particulates in a powdered material. Specifically, the materials useful herein are effective in reducing the release of particulates in a powder to be applied to the skin, and especially the skin of babies.

Background

[0002] For years, individuals have been applying powder-based materials and compositions to skin to provide a beneficial effect. In many instances, these compositions are applied to the skin of babies and young children to help reduce skin irritation and rash. Such compositions are commonly referred to as “baby powder”, and may include components such as cornstarch or talc.

[0003] However, being a particulate composition, it is difficult to accurately and precisely apply such baby powder to the exact target location of the skin of the user, as there is a tendency of small components to be “dusted”, that is, smaller particles of the composition are released into the air in the vicinity of the skin to which the composition is to be applied. This release of powder, or dusting, reduces the amount of material actually applied to the target site.

[0004] There is currently a need to provide components and materials to known powdered compositions to reduce the “dusting” effect, in order to reduce dusting and to more accurately apply the powder composition to the target site.

Summary

[0005] In one aspect of the invention, there is a combination particulate composition that is effective in providing beneficial effect to the skin of a user, while controlling the airborne dusting when applied or manufactured, and also increasing the precision and/or accuracy of application when dispensed onto the skin of a user. The combination particular composition may include a first powder component including a plurality of particles including starch or a polysaccharide bearing at least one hydroxyl moiety and a second powder component including a plurality of particles including linear hydrophobic cellulose particles.

[0006] The invention may further include a method of reducing dusting of a particulate composition including combining a first powder component including a plurality of particles including starch or a polysaccharide bearing at least one hydroxyl moiety with a second powder component including a plurality of particles including linear hydrophobic cellulose particles, thereby forming a combination particulate composition with a lesser dusting profile than a composition without the second powder component.

[0007] Kits and packaged products including the combination particulate composition may be included and provided to a user for application and use by the user.

Brief Description of Figures

[0008] Figure 1A shows a side view of the drop test setup. Figure 1B shows a measurement of the beaker used in the drop test. Figure 1C shows a top view of the drop test setup.

[0009] Figures 2-7 are photographs of the results of tests done in Example 1 of the present invention:

[00010] Figure 2 shows the beaker including 100% talc after the drop test of Example 1.

[00011] Figure 3 shows the beaker including 100% cornstarch after the drop test of Example 1.

[00012] Figure 4 shows the beaker including 100% cellulose particles after the drop test of Example 1.

[00013] Figure 5 shows the beaker including 50%/50% cellulose particle/cornstarch after the drop test of Example 1.

[00014] Figure 6 shows the dust measurement for small particle sizes in Example 1.

[00015] Figure 7 shows the dust measurement for large particle sizes in Example 1.

Detailed Description

[00016] The present invention relates to components and materials for use in powdered compositions, as well as the resulting combination material including powdered compositions with added components or materials. The resulting combination particulate material has a reduced tendency to release particles airborne during use (“dusting”, described below), and also provides a more controlled and localized accuracy when applying to a target site.

[00017] As used herein, the term "particle" or "particulate" means a small localized object to which can be ascribed physical properties such as volume or mass. As used herein, "powder" is used to refer to a composition including a plurality of "particles", as defined herein. A particle may be spherical but need not be spherical, it may have a length and width (or diameter), thereby providing an aspect ratio greater or less than 1. In some aspects, the particle may have an amorphous shape.

[00018] The compositions described herein are useful for application to a body, and specifically to the skin of a body, such as human skin. The human skin to which compositions described herein is useful includes, for example, adult skin, baby skin, or skin of a young child, such as a toddler. Compositions described herein may be used on skin that has a higher sensitivity to irritation, or skin that has a lower sensitivity to irritation.

[00019] Certain powders are known to be beneficial when applied to skin, such as to provide a reduction in irritation or to prevent rash or itching. Particularly in the case of application to babies, it is known to use "baby powder" on the skin of a baby. However, the term "baby powder" does not limit its application to babies alone, and such baby powder products may be applied to the skin of older children or adults. In some territories, baby powder may include or consist essentially of starch or polysaccharides bearing hydroxyl moieties (such as cornstarch), while in other territories, baby powder may include or consist essentially of talc, while in still other territories, baby powder may include combinations of cornstarch and talc. Baby powder may include other ingredients (referred to as "Additional Baby Powder Components"), such as fragrances or perfumes, including oils or extracts such as aloe, lavender, and chamomile, or may include cooling agents such as menthyl lactate and isopulegol. Other Additional Baby Powder Components include, for example, opacifying agents, including calcium salts such as tricalcium phosphate; bulking agents such as magnesium stearate; antioxidants, such as sodium ascorbyl phosphate; preservatives, such as chloroxylenol; parabens, such as propylparaben or methylparaben, vitamins such as Vitamin E; sun agents such as zinc oxide; humectants, such as betaines or glycerin; pH adjusters, including acids and citrates; skin conditioners, such as milk protein, copper gluconate, magnesium aspartate, zinc clugonate, panthenol, tocopheryl acetate, and propylene glycol; sodium bicarbonate, bisabolol, tocopherol, silica; and other materials that may be added to commercial powders. The term "consisting essentially of" as used herein with reference to a baby powder composition does not preclude the use of these Additional Baby Powder

Components. By way of example, a fragrance or mixture of fragrances may be included in the baby powder composition in an amount of from about 0.01% to about 0.5% by weight of the baby powder composition. Similarly, by way of example, opacifying agents such as calcium salts may be present in an amount of from about 0.25% to about 0.75% by weight of the baby powder composition.

[00020] Baby powder includes a powdered composition that may be applied to the skin of a human, and may include starch or polysaccharides bearing hydroxyl moiety, talc, and/or clay-derived substances (such as kaolin). The term “starch” includes a polysaccharide consisting of a large number of glucose units joined by glycosidic bonds, including starch derived from sources such as corn and tapioca, and the term “cornstarch” refers to starch specifically obtained from corn. Cornstarch may include trace amounts of minerals such as iron, sulfur dioxide, ash, and oxidizing substances, which are inherent in cornstarch. Cornstarch powder useful in the present invention may have a moisture percentage of about 11.5% or less, where about 100% of the particles pass through a 60 mesh (U.S.S.) screen, greater than about 99% of the particles pass through a 100 mesh screen, and greater than about 98% of particles pass through a 200 mesh screen. Suitable cornstarch may be supplied by Ingredion, under the trade name Corn Products™, powdered dusting corn starch 034500. For this application, when the terms “cornstarch” or “cornstarch powder” are used to describe a composition, that composition consists essentially of cornstarch (but it may include Additional Baby Powder Components identified above, such as fragrance, humectants, calcium salts, or preservatives).

[00021] The term “talc” or “talcum powder” means a natural hydrous magnesium silicate mineral, which may be beneficiated, milled, and processed to a fine white powder. The term “talc” or “talcum powder” may include minerals such as dolomite and/or chlorite, which are inherently found in high purity talc. The amount of additional (non-talc) minerals is about 2% or less by weight of the talcum powder. Suitable talc includes about 99.5% or greater of the particles passing through a 200 mesh screen (U.S.S.), with a median diameter of about 10.5 microns particle size distribution. Suitable talc may be supplied by Luzenac, under the trade name Grade 25 USP talc. For this application, when the terms “talc” or “talc powder” is used to describe a composition, that composition consists essentially of talc (but it may include Additional Baby Powder Components identified above, such as fragrance, opacifying agents, or preservatives).

[00022] The present invention provides various components to be added to or combined to form baby powder compositions, as well as the resulting combination of baby powder compositions and such added materials, as well as methods of making and methods of using such resulting combination of baby powder compositions and added materials.

[00023] In one particular embodiment, the resulting combination product includes baby powder mixed with a desirable amount of a particulate cellulosic material, and in some embodiments, that cellulosic material may be powdered material obtained from cotton. The baby powder may be a powdered cornstarch composition, or it may be a powdered cornstarch/talc combination material. Thus, the resulting combination product described herein may include particulate cellulosic material with powdered cornstarch, or it may include particulate cellulosic material with powdered cornstarch and talc, or it may include particulate cellulosic material with powdered cornstarch and clay-derived materials, such as kaolin. Additional Baby Powder Components identified above may also be included.

[00024] It has been discovered by the present inventors that the addition of cellulosic materials in a particulate or powdered form can provide significant benefit to baby powder, specifically baby powder including cornstarch or consisting essentially of cornstarch. The combination powder can be applied more accurately, with less risk of dusting, and still provide a benefit to the skin, such as reduction in irritation, reduced likelihood of rash or irradiation, and the like. It is particularly preferred that the cellulosic materials consist of cotton or consist essentially of cotton, as will be described below, to maintain a low risk of irritation and rash.

[00025] The cellulosic materials are particulate, and may be spherical, amorphous, or linear particles, or combinations thereof. As used herein, the term "linear particle" means a particle having one dimension ("length") that is greater than another dimension (e.g., "diameter" or "width"). Linear particles may be measured and defined by size by subjecting such particles to analysis with respect to a series of sieves having different mesh sizes. Generally, a sample of linear particles may have a distribution of particle sizes throughout the sample. Thus, linear particle sizes as expressed herein are expressed as an average particle size and reflect the average length of the particles contained within the sample. A linear particle need not be perfectly straight or have a consistent width and/or length throughout, it may have some irregular sides and still be considered substantially linear.

[00026] Preferably, the average size of linear particles useful in the compositions and methods of this invention is less than about 1000 μm in length, or less than about 700 μm in length, or less than about 500 μm in length, or more preferably, it ranges from about 2 to about 1000 μm , or from about 50 to about 700 μm , or from about 100 to about 600 μm . The width or diameter of linear particles useful in the compositions and methods of this invention is about 1 to about 100 μm , or from about 2 to about 50 μm in width or diameter, or from about 2 to about 40 μm in width or diameter.

[00027] As used herein, the term "particle aspect ratio" means the ratio of the length of a particle to its width or diameter. Preferably, the particle aspect ratio of linear particles useful in the compositions and methods of this invention is from about 2 to about 20. More preferably, the particle aspect ratio is from about 2 to about 15 and most preferably, from about 2 to about 10. The particulate compositions used herein may include linear particles and spherical particles in combination, if desired.

[00028] As used herein, the term "cellulose" refers to a polysaccharide material consisting of long unbranched chains of linked glucose units.

[00029] Cellulose materials useful in the compositions and methods of this invention may be derived from cotton, corn, wood pulp and bamboo pulp, silk, cork and the like. Preferably, the cellulose materials useful in the compositions of this invention are derived from cotton. The cellulosic particles may be from fibers recovered from post-industrial scrap or may be derived from raw cotton. Scrap is derived from waste or other pre-consumer cotton products from, for example, the apparel, carpet, furniture and household goods industries. Synthetic or regenerated cotton or cellulose materials may also be used as sources for the cellulose particles useful in the compositions and methods of this invention, including rayon, viscose, cellophane, and other cellulosic materials with a uniform and reproducible molecular size and distribution.

[00030] The cellulose materials useful in the compositions and methods of this invention may be derived directly from the source plant (referred to herein as, "Raw" particles) or may be generated from cloth or nonwoven materials previously formed from plant or cellulose fibers (referred to herein as "regenerated" particles). For example, cotton cloth may be processed so as to break the cloth into small particles and/or fiber lengths by cutting the length of the cotton fibers from inches to microns. This cut fiber is available in

several grades, white, dark, and unbleached, with average fiber lengths described above. The cut fibers may be substantially uniform in length and/or width, or may be random.

[00031] Typical mechanical milling processes such as those useful in cutting down the size of the cellulose materials useful in the compositions and methods of this invention, for example, are described in U.S. Pat. No. 7,594,619 and U.S. Pat. No. 6,656,487, which are hereby incorporated herein by reference.

[00032] Generally, the cellulose particles useful in the compositions of this invention may be processed according to the any known methods. One such method comprises mixing a cellulosic material derived from scrap, as defined above, with at least one of grinding aids selected from the group including water, fatty acids, synthetic polymers and organic solvents, and, after mixing, mechanically grinding the mixture.

[00033] Another method of obtaining cellulose particles is freezing a cellulosic material derived from post-industrial scrap at a low temperature, and then mechanically grinding said frozen material. Cellulose particles useful herein may be hydrophobic or may be hydrophilic.

[00034] The cellulose particles useful in the compositions and methods of this invention may be further treated with hydrophobic agent(s) to yield more hydrophobic cellulose particles. For example, a hydrophobic coating agent may be used to treat the cellulose particles. The hydrophobic coating agent may be any such agent known to one of skill in the art. Hydrophobic coating agents react chemically with the cellulose particles to provide a durable covalent bond thereto and have hydrophobic chemical backbones or substituents that can provide a hydrophobic outer layer around each individual cellulose particle. The coating agent may react, for example, with hydroxyl groups, available oxygen atoms present on the surface of the cellulose particle being coated.

[00035] Hydrophobic agents may include, but not limited to, low water soluble organic compounds such as metal soap, e.g., a metal myristate, metal stearate, a metal palmitate, a metal laurate or other fatty acid derivatives known to one of skill in the art. Other hydrophobic agents may include an organic wax, such as a synthetic wax like polyethylene or a natural wax like carnauba wax. Hydrophobic agents useful in coating the cellulose particles useful in the compositions and methods of this invention may also be long chain fatty acids or esters such as stearic acid, oleic acid, castor oil, isododecane, silicone, and their derivatives, non-water soluble polymers, e.g. high molecular weight methylcellulose and ethylcellulose,

and high molecular water insoluble fluoropolymers etc., polymerized siloxanes or polysiloxanes with the chemical formula $[R_2SiO]_n$, where R is an organic group such as methyl, ethyl, or phenyl, such as dimethicone, dimethicone copolyol, dimethicone ester; methicone and their derivatives. Examples of hydrophobic linear cotton particles useful in the present invention include, but are not limited to, Cotton Fiber Flock CD60 available from Goonvean Fiber and W200 and W325 White Cotton Flock available from International Fiber Corporation.

[00036] The combination material prepared from the present invention includes a first powdered component consisting essentially of cellulose powder, and a second powdered component including baby powder. The baby powder of the second powdered component may include or consist essentially of starch (such as cornstarch), clay-based materials, and/or talc. It is preferred that the average size of the particles of the first powdered component and the second powdered component be substantially similar, that is, when mixed together, the first powdered component and the second powdered component are not easily separable from each other due to their relative sizing.

[00037] The combination material may include any desired amounts of the first powdered component and the second powdered component. For example, there may be from about 5% to about 80% of the first powdered material by weight of the combination material, or about 10% to about 50% of the first powdered material by weight of the combination material, or about 10% to about 40% of the first powdered material by weight of the combination material, or about 15% to about 20% of the first powdered material by weight of the combination material. The remaining material(s) forming the combination material may include the second powdered component, which may include or consist essentially of starch (such as cornstarch), clay-based materials, talc, or combinations thereof (such as talc and starch in combination).

[00038] Thus, in one embodiment, a combination material includes a first powdered component including or consisting essentially of cellulose particles in an amount of about 5-20% by weight of the combination material, and a second powdered component including or consisting essentially of starch particles in an amount of about 80-95% by weight of the combination material. An alternative combination material includes a first powdered component including or consisting essentially of cellulose particles in an amount of 75% by weight, and a second powdered component including or consisting essentially of starch

particles in an amount of about 25% by weight. An alternative combination material includes a first powdered component including or consisting essentially of cellulose particles in an amount of about 5-50% by weight of the combination material, and a second powdered component including or consisting essentially of starch particles in an amount of about 25-50% by weight of the combination material, and an optional third powdered component including or consisting essentially of talc particles in an amount of about 25-45% by weight of the combination material. As noted above, the relative percentages may vary, with the first powdered component being present in an amount as described above, and the second powdered component (or second and third powdered components) forming the remaining part of the combination material.

[00039] The combination of the first powdered component and second powdered component (and optional third powdered component) may equal 100% of the final composition, or the combination may equal less than 100% of the total composition, if Additional Baby Powder Components such as fragrances, dyes, preservatives, vitamins, dyes, humectants, emollients or other additives are included in the final combination particulate composition. For example, the combination particulate composition may include a first powdered component and a second powdered component, and optionally a third powdered component, in an amount totaling about 95% to about 99.99% by weight of the combination particulate composition, with the remaining 0.01-5% of the combination particulate composition including Additional Baby Powder Components described above, such as added vitamins, fragrances, humectants, or other additives, alone or in combination with other Additional Baby Powder Components. In some instances, the amount of Additional Baby Powder Components may be up to 10% by weight of the final composition, or may be from about 0.01-5% by weight of the final composition, or may be from about 0.1-2% by weight of the final composition.

[00040] It is desired that there be as little water or aqueous material in the resulting combination material as practical, with the understanding that certain powdered materials may inherently absorb moisture. Desirably, the resulting combination material includes less than 1% by volume aqueous material or less than 0.1% by volume aqueous material, such as water.

[00041] The Applicant has discovered that the incorporation of a cellulose powder material into a powdered cornstarch composition provides benefits, including, for example,

reduction in the amount of airborne dust particles and more targeted delivery of the combination composition. By way of example, it is noted that incorporating about 50% cellulose powder into a powdered cornstarch composition reduces the amount of airborne dust particles of a cornstarch composition alone by about 140%. In addition, the Applicant has discovered a reduction in airborne dust particles when there is a “one for one” replacement of both cornstarch and talc with cellulose powder. When compared to a cornstarch composition alone, the inclusion of cellulose powder reduces the amount of airborne dust particles by about 340%. When compared to a talc composition alone, inclusion of cellulose powder reduces the amount of airborne dust particles by about 1650%. Other benefits and levels are set forth in the Examples below.

[00042] Surprisingly, however, the Applicant has discovered that the inclusion of cellulose particles into a composition consisting essentially of talc powder does not necessarily have an effect of reducing the amount of dust borne particles when cellulose is added at certain amounts. This will be discussed in more detail below in the Examples, but this demonstrates that inclusion of cellulose particles into any powdered composition does not inherently cause a reduction in the amount of airborne dust particles into the air during use. Further, it can be seen that addition of certain levels of cellulose into compositions has a different affect based upon the amount of cellulose and the type of other components in the composition. For example, while cellulose in a cornstarch composition provides benefit at various levels tested, it actually provided increased benefit when added in lower amounts. When added to talc compositions, the benefit increased as cellulose was increased, but once the amount of cellulose reached a certain level (50%), the benefit was not seen and dusting increased. Thus, the present inventors have discovered a surprising and unexpected benefit when cellulose is added to compositions including cornstarch, where the benefit is not inherently seen in every powdered composition.

[00043] The combination materials of the present invention should include at least a first powdered composition including cellulose particles and a second powdered composition consisting essentially of starch or any polysaccharides bearing hydroxyl moieties (such as cornstarch), and may optionally include a third powdered composition consisting essentially of talc or clay-based components.

[00044] The combination powdered material may be prepared by any desired methods, including, for example, simple mixing by combining materials in a container and stirring or

shaking to combine the materials. Other equipment for mixing materials may be used, including, for example, using a rotary batch mixer, a vee-cone blender, a fluidized bed mixer, a ribbon, paddle and plow blender, continuous blenders, and the like. If wet ingredients are included, they may be incorporated by spraying into a mixer before, during or after mixing of the dry (powdered) components. After blending, there is desired a substantially homogenous distribution of a first powdered component and second powdered component, as described above.

[00045] The combination material described herein may be used by applying the combination material directly or indirectly to the skin of a human, including, for example, the skin of an adult human, a baby human, or a child human. The combination material may be applied to any skin region desired, and may be left in place after application or may be rubbed or otherwise massaged onto the skin after application. In some embodiments, the combination material may be applied to an applicator, which may be a fabric or cotton applicator or wipe, or in some instances may be the hand of a user, and then applied to the target skin region. The combination materials herein are effective in controlling the accuracy and precision to the target site when the powder is poured or dispensed from a package (e.g., “dusting”). Further, the combination materials herein have low skin irritation and may be used on sensitive skin surfaces, such as the diapered region of a baby.

[00046] In some instances, the combination of a cellulose powder and a second (or optionally, third) powdered material may improve moisture absorption and/or oil absorption when used. Certain cellulosic materials, such as cotton as described above, have lipophilic and hydrophilic properties, and therefore absorption of one or both of water and oil may be improved through the present invention.

[00047] The present invention includes a package or kit including the first powdered material including or consisting essentially of cellulose materials and a second powdered material including or consisting essentially of starch, such as cornstarch. The package or kit includes indicia indicating the source of the materials and the amounts thereof. The package may further include a third powdered material including or consisting essentially of talc. The package may include a partially open or slotted cap to allow for pouring or dispensing of the combination powdered material to a target site.

Examples

[00048] The following examples are not intended to be limiting, but rather exemplify various embodiments of the present invention.

Example 1 – Airborne Dusting Drop Test

[00049] Using the drop test as pictured in Figures 1A-1C, the amount of airborne particles that are released into the air after dropping a powder composition was measured. The intent was to determine the amount of particles that are released into the air after dropping various powder compositions, as well as to determine the settling time and amount after dropping is complete. It is believed that less dusting and faster settling time will allow for more controlled application of a powdered material to a target site, such as skin of a user. Various compositions including cellulose powder, cornstarch powder, talc powder, and combinations were tested.

[00050] For this experiment, a stand was used to hold a rod with a measuring spoon (one teaspoon) in a fixed location directly over an open and clean beaker. See Figures 1A, 1B, and 1C. The height of the spoon measured 12.5 inches from the surface and remained constant for the duration of the experiment. Amounts of each sample were measured equal by volume (though the weight of each sample was recorded for informational purposes). To prepare the sample, the rod was removed, filled to the top, and leveled off with a straight edge tongue depressor to ensure equal volume. Once filled, the rod was placed into the clamp to ensure it was held at a fixed distance from the surface. A Dylos Air Quality Monitor DC1100 PRO was placed directly in front of the beaker.

[00051] The air quality monitor was turned on and placed in continuous mode. A baseline particle count was taken for each sample before its drop into the beaker. The baseline gives the particles that are present in the surrounding environment before the sample is introduced. This was taken to ensure the surrounding air was consistent for each sample (baseline measurements were not included in the data analysis). After recording the baseline, the rod was manually turned to the right side to allow the sample to drop straight down into the beaker with minimal applied force. For these purposes, the amount of force needed to manually turn the rod to the right can be considered approximately equal for each sample tested. The major force acting on each sample is that of gravity. The intention was to provide a simple drop test that was as close to freefall as possible. Of course, it is understood that some minimal force would have to be applied to turn the sample.

[00052] As soon as the rod was turned and the product was dropped, a timer was started. Particle measurements were taken every 15 seconds for two minutes. After two minutes were complete, the monitor was turned off, removed from the area, and sprayed twice with a compressed air can, so as to clean out any particles that may have settled into any of the openings in the back. After two minutes was complete, a picture was then taken of the beaker to help visually note differences in the amount of dust produced by each sample. This shows not only the amount of dusting on the sides of beaker, but the height of the dusting that was reached due to the impact the sample had after being dropped. This experiment was repeated three times for each sample.

[00053] Five powdered samples were tested. Sample 1 was 100% cornstarch powder (Ingredion Corn Starch 034500), the corn starch having a particle size maximum of 250 microns (where 100% passed through a 60 mesh filter). Sample 2 was 100% Grade 25 USP talc powder supplied by Luzenac (where about 98.5% passed through a 74 micron (200 mesh) filter, and about 99.7% passed through a 149 micron (100 mesh) filter, and 100% passed through a 250 micron (60 mesh) filter). Sample 3 was 100% cellulose powder W325J (white cotton flock), having an average particle size of 44.04 microns in diameter and 80.20 microns in length. Sample 4 was a 50/50 blend of cornstarch powder and cellulose powder W325J. Sample 5 was a 50/50 blend of talc powder and cellulose powder W325J. A representative picture taken for 100% talc after the drop test is shown as Figure 2; a representative picture taken for 100% cornstarch after the drop test is shown as Figure 3; a representative picture taken for 100% cellulose particles after the drop test is shown as Figure 4; a representative picture taken for 50%/50% cellulose particle/cornstarch after the drop test is shown as Figure 5.

[00054] The experiment was performed three times for each sample. For each drop test run, fresh material was weighed and a new beaker was used. The Air Quality Monitor was used to measure the count of both smaller particles ($> 0.5 \mu/\text{ft}^3$) and larger particles ($> 2.5 \mu/\text{ft}^3$). The values both shown on the monitor and recorded during the experiment are representative of particles that are present in 0.01 ft^3 of sampled air. For example, the data obtained for the baseline measurement during Trial 1 of 100% Corn Starch can be described as follows: The small particle count of 272 signifies that there are 272 particles equal to or greater than 0.5 micrometers per 0.01 cubic feet of air, or 272,000 particles per cubic foot.

The particle count of 3 signifies that there are 3 particles greater than or equal to 2.5 micrometers per 0.01 cubic feet of air, or 3,000 particles per cubic foot.

[00055] When turned on, the monitor automatically goes into continuous mode, which continually takes measurements until turned off. This mode was used for these experiments.

[00056] The table below shows the small particle count measurements averaged for each 15 second time point, with each of the three trials averaged below. Each total average represents an average number of particles per 0.01 cubic feet for all three trials. The baseline measurement (T=0) is not included in the Total Average.

Table 1 – small particle count measurements

Time (sec)	100% Cornstarch	100% Talc	100% Cellulose Powder	50/50 Cornstarch/Cellulose	50/50 Talc/Cellulose
0	255	300	300	236	299
15	2747	12048	488	1210	15602
30	2842	12432	556	1572	19130
45	2731	12525	591	1614	21593
60	2156	12856	584	1691	21114
75	739	4411	358	944	11277
90	345	2096	277	436	4852
105	256	1096	238	308	1492
120	236	472	238	229	746
Total Average	1507	7242	416	1001	11976

[00057] Trends in the form of line graphs for the measurements can be seen as Figure 6 (small particle size count) and Figure 7 (large particle size count). These results indicate that the measurements for large and small particle sizes were consistent among the various samples.

[00058] Cornstarch produces about 3.4 times more dusting than cellulose particles itself, and cornstarch also produces about 1.4 times more dust particles than a blend of 50/50 cornstarch and cellulose particles. Talc by itself produces about 16.5 times more dusting than cellulose particles alone, and talc produces about 4.9 times as much dusting particles than cornstarch alone. Further, talc alone produces about 6.9 times as much dusting particles as the 50/50 blend of cornstarch and cellulose particles.

[00059] It was surprising that the 50/50 blend of talc and cellulose particles produced a higher degree of dusting particles than talc powder by itself. When looking at the dusting provided by individual components, it can be seen that cellulose powder by itself has the least amount of dusting, followed by cornstarch. When cellulose particles and cornstarch are combined, the result was an improved dusting profile of the blend. However, when talc and cellulose particles were combined into a blend, there was a different effect – the inclusion of cellulose particles into talc powder actually provided a greater dusting particle profile. Therefore, it cannot merely be said that the inclusion of cellulose particles into a composition will necessarily reduce its dusting profile. Rather, it is the combination of cellulose particles and cornstarch that produces a beneficial reduction in dusting particles.

[00060] Similarly, the height of the particles adhered to the sides of the beakers was also measured to give a sense of the size of the dusting plume that is generated when dropped. Cellulose particle powder dropped by itself reached a height of 0.25 inches in the beaker (Figure 4). Cornstarch by itself demonstrated a dusting height of 1.25 inches in the beaker (Figure 3), while cornstarch plus cellulose particles demonstrated a height of 0.60 inches. Thus, the combination of cellulose particles and cornstarch was effective in reducing the height of the dusting plume.

[00061] Again, however, it was also surprisingly found that the combination of cellulose particles and talc again resulted in a greater dusting plume than talc by itself. Talc by itself reached a height of 2.0 inches, while the talc/cellulose combination actually exhibited a dusting plume that was higher than the size of the beaker. Conventional thinking would have been that the high dusting of talc would have been reduced by adding cellulose particles, however, the combination result exhibited greater dusting than talc by itself. This was again a result that indicates the inclusion of cellulose particles by itself into any powdered material does not necessarily reduce its dusting profile.

Example 2 – Dusting With Smaller Levels of Cellulose

[00062] Compositions including smaller levels of cellulose material were tested, using the same method described above in Example 1, with the same cellulose powder W325J (white cotton flock), and similar talc and cornstarch materials. Tests were run using compositions that were hand mixed in a beaker using a tongue depressor, with ratios of: 10% cellulose and 90% cornstarch, 20% cellulose and 80% cornstarch, 10% cellulose and 90% talc, 20% cellulose and 80% talc, and 5% cellulose and 95% cornstarch. Table 2 below shows the small particle count measurements averaged for each 15 second time point, with each of the three trials averaged below. Table 3 shows large particle count measurements. Each total average represents an average number of particles per 0.01 cubic feet for all three trials. The baseline measurement (T=0) is not included in the Total Average.

Table 2 – small particle count measurements

Time (sec)	10% Cellulose- 90% Cornstarch	20% Cellulose-80% Cornstarch	10% Cellulose- 90% Talc	20% Cellulose- 80% Talc	5% Cellulose and 95% Talc
0	821	692	879.3333	434.6667	1323
15	1219.333	1246.333	3459.333	1369	1440.666667
30	1429.333	1348.667	4096.333	1513.333	1449.333333
45	1438	1355	4167	1514.667	1483.666667
60	1442.333	1163.667	3450.333	1327.333	1461
75	942	737.3333	1279.333	468.3333	1378.333333
90	813	695.3333	904.3333	429	1368.333333
105	789	669.6667	814	422.3333	1355.666667
120	780.6667	669.3333	800.3333	416.6667	1327.333333
Total Average	1106.70821	985.6667	2371.375	932.5833	1408.042

Table 3 – larger particle count measurements

Time (sec)	10% Cellulose- 90% Cornstarch	10% Cellulose- 90% Talc	20% Cellulose- 80% Cornstarch	20% Cellulose- 80% Talc	5% Cellulose and 95% Talc
0	92.66667	89.66667	68.33333	41	133.3333333
15	440.6667	2492	483.3333	736	228
30	578.3333	2996.333	573.3333	829.3333	243.3333333
45	593.6667	3015.333	576	834.3333	271
60	582.3333	925.3333	426.3333	699	245.6666667
75	198.6667	344.3333	106.6667	75.33333	176.3333333
90	104.3333	158.6667	68.66667	53.33333	158.6666667
105	93	102	62	45	140
120	85.66667	98.33333	62.33333	43.33333	129.3333333
Total Average	334.583	1266.542	294.83	414.458	199.041

[00063] Since the baseline for airborne particles was different for different ratios tested above, the percentage increase/decrease in particles was measured. This percentage change reflects a more understandable and accurate comparison between the various ratios tested. The results are set forth in Tables 4 and 5 below.

Table 4 – Percentage Increase - small particle count measurements

% increase in small particle dusting	10% Cellulose- 90% Cornstarch	20% Cellulose-80% Cornstarch	10% Cellulose- 90% Talc	20% Cellulose- 80% Talc	5% Cellulose and 95% Talc
0-15	48.52	80.11	293.40	214.95	8.89
15-30	74.10	94.89	365.85	248.16	9.55
30-45	75.15	95.81	373.88	248.47	12.14
45-60	75.68	68.16	292.38	205.37	10.43
60-75	14.74	6.55	45.49	7.75	4.18
75-90	0.97	0.48	2.84	1.30	3.43
90-105	3.90	3.23	7.43	2.84	2.47
105-120	4.91	3.28	8.98	4.14	0.33
Avg	37.25	44.06	173.78	116.62	7.30

Table 5 – larger particle count measurements

% increase in larger particle dusting	10% Cellulose-90% Cornstarch	10% Cellulose-90% Talc	20% Cellulose-80% Cornstarch	20% Cellulose-80% Talc	5% Cellulose and 95% Talc
0-15	375.54	2679.18	607.32	1695.12	71
15-30	524.10	3241.64	739.02	1922.76	82.5
30-45	540.65	3262.83	742.93	1934.96	103.25
45-60	528.42	931.97	523.90	1604.88	84.25
60-75	114.39	284.01	56.098	83.74	32.25
75-90	12.59	76.95	0.49	30.08	19
90-105	0.36	13.75	9.27	9.76	5
105-120	7.55	9.67	8.78	5.69	-3
Avg	262.95	1312.5	335.98	910.87	56.75

[00064] Due to the measured baseline varying at different data points for various ratios of compositions, the data was normalized using percent increase in air borne particle count. For smaller particles, it can be observed that 10% cotton with cornstarch provided approximately 4.5 times less dusting than 10% cotton with talc. At the same time, the composition including 20% cotton with cornstarch provided approximately 2.5 times less dusting than 20% cotton with talc.

[00065] It was observed that as the percentage of cellulose in a talc-containing composition is increased, the dusting decreases, however, it was surprising to understand that as percentage of cotton in a cornstarch composition decreases, the resulting dusting property also decreases. As can be seen, while a composition including 10%-20% cellulose (with cornstarch) is helpful in reducing dusting, as the amount of cellulose is added to a cornstarch-containing composition, the dusting is reduced even further. This was an unexpected result,

and demonstrates that the mere addition of cellulose does not provide a linear dusting reduction. It cannot therefore be said that simply adding a cellulose component reduces dusting in the same way in every composition.

[00066] Based upon the various tests conducted by the inventors, the inclusion of cellulose in a cornstarch containing composition provides a benefit in the reduction of dusting and therefore more targeted application of the composition, but the benefit of adding cellulose is not necessarily the same when used in a different composition, such as a talc-containing composition. Further, although one can see that adding a greater amount of cellulose (from 10 to 20%) in a talc composition reduces dusting, the opposite holds true for a cornstarch-containing composition, where the reduction in cellulose from 20 to 10 and to 5% actually reduced dusting greater. Further, it was noted that the 5%/95% cellulose/cornstarch composition provided a nice feel to the skin when applied, with minimal clumping or aggregation of components on the skin.

[00067] A composition including cellulose in an amount of 5%, 10% and 20% in a cornstarch-containing composition provides a benefit that was surprising to the present inventors. This result, in combination with the results seen in Example 1, demonstrates an unexpected effect when varying amounts of cellulose are added to cornstarch-containing compositions.

What is claimed is:

1. A composition comprising:
 - a. a first powder component comprising a plurality of particles comprising starch or a polysaccharide bearing at least one hydroxyl moiety; and
 - b. a second powder component comprising a plurality of particles comprising linear hydrophobic cellulose particles.
2. The composition of claim 1, wherein said first powder component consists essentially of starch or a polysaccharide bearing at least one hydroxyl moiety.
3. The composition of claim 1, wherein said linear hydrophobic cellulose particles are derived from cotton.
4. The composition of claim 3, wherein said cotton is regenerated cotton.
5. The composition of claim 1, wherein said first powder component and said second powder component are present in said composition in a ratio of about 95:5 to about 50:50 by weight of each component.
6. The composition of claim 1 wherein said first powder component and said second powder component are present in said composition in a ratio of about 90:10 by weight of each component.
7. The composition of claim 1, further comprising a third powder component comprising a plurality of particles comprising talc.
8. The composition of claim 1, wherein said starch or a polysaccharide bearing at least one hydroxyl moiety is derived from corn.
9. The composition of claim 1, wherein said linear hydrophobic cellulose particles have a length of about 2 microns to about 500 microns.
10. The composition of claim 1, wherein said linear hydrophobic cellulose particles have a diameter of about 1 to about 25 microns.
11. The composition of claim 1, wherein said linear hydrophobic cellulose particles have an aspect ratio of about 2 to about 10.
12. A method of reducing dusting of a particulate composition comprising combining a first powder component comprising a plurality of particles comprising starch or a

polysaccharide bearing at least one hydroxyl moiety with a second powder component comprising a plurality of particles comprising linear hydrophobic cellulose particles, thereby forming a combination particulate composition with a lesser dusting profile than a composition without said second powder component.

13. A method of reducing skin irritation comprising the step of applying to a target skin site a composition comprising:
 - a. a first powder component comprising a plurality of particles comprising starch or a polysaccharide bearing at least one hydroxyl moiety; and
 - b. a second powder component comprising a plurality of particles comprising linear hydrophobic cellulose particles.
14. The method of claim 13, wherein said first powder component consists essentially of starch or a polysaccharide bearing at least one hydroxyl moiety.
15. The method of claim 13, wherein said linear hydrophobic cellulose particles are derived from cotton.
16. The method of claim 15, wherein said cotton is regenerated cotton.
17. The method of claim 13, wherein said first powder component and said second powder component are present in said composition in a ratio of about 95:5 to about 50:50 by weight of each component.
18. The method of claim 14, wherein said first powder component and said second powder component are present in said composition in a ratio of about 90:10 by weight of each component.

1/5

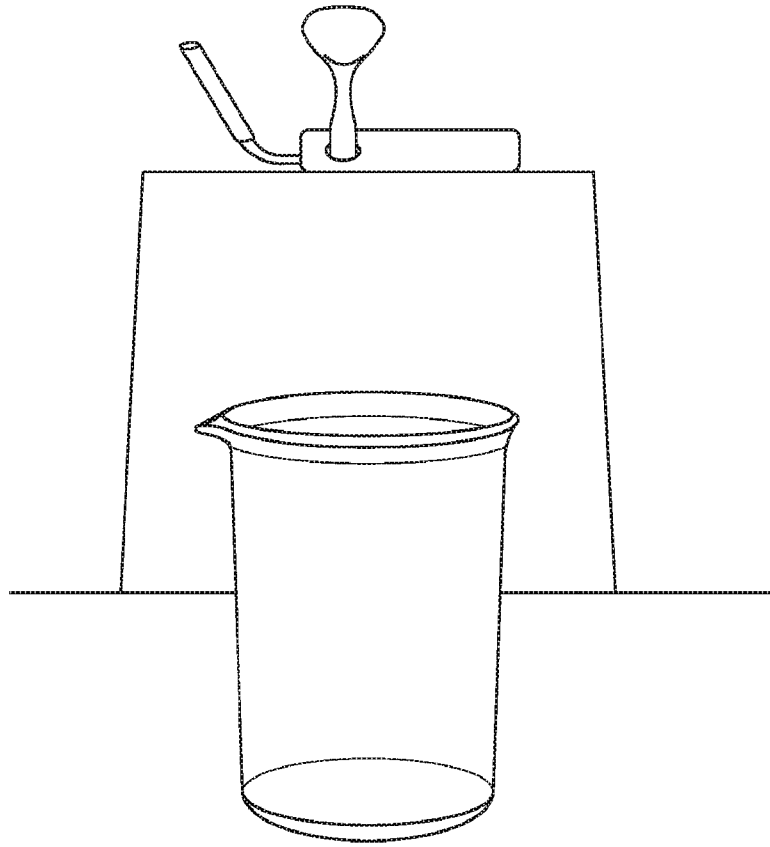

FIG. 1A

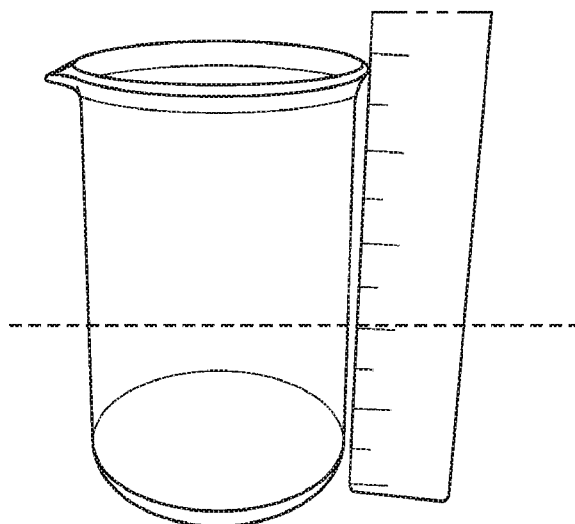

FIG. 1B

2/5

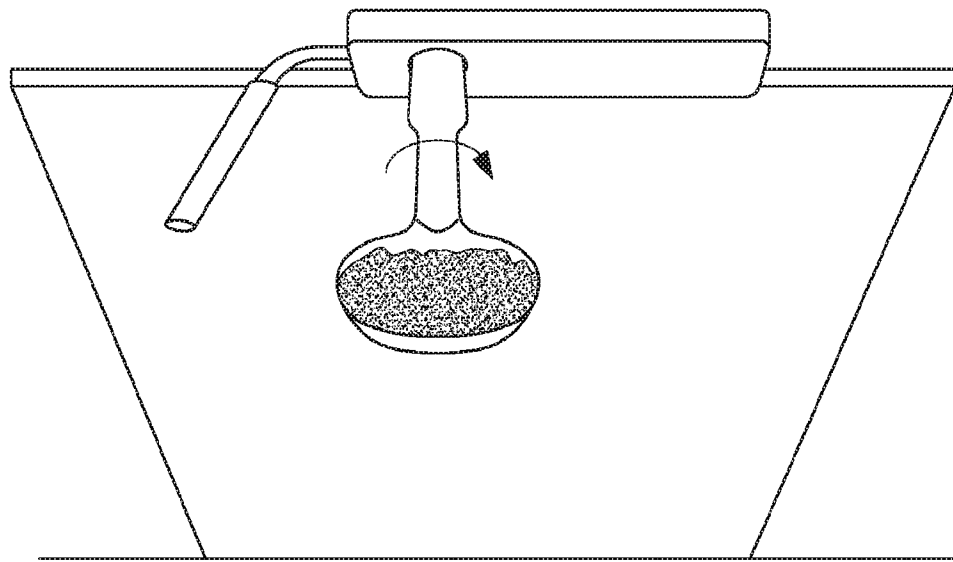

FIG. 1C

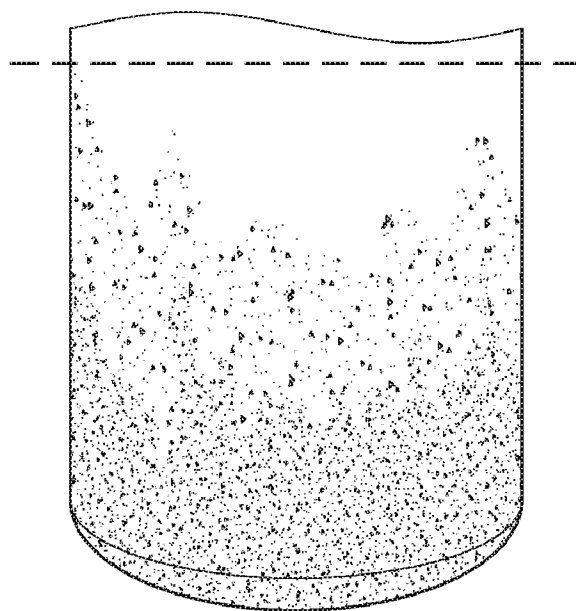

FIG. 2

3/5

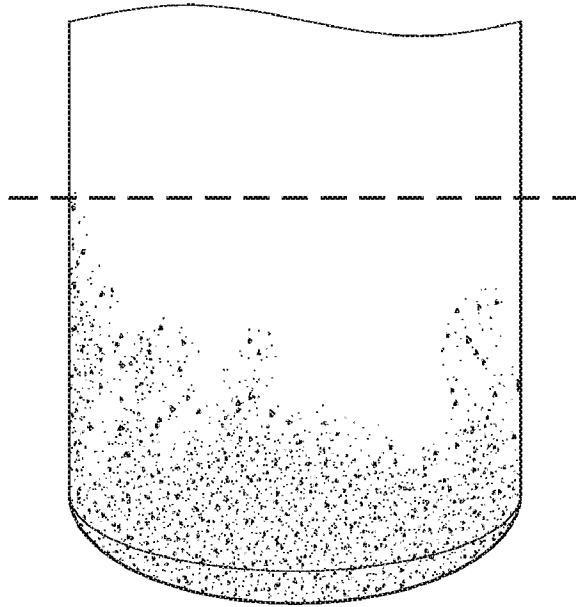

FIG. 3

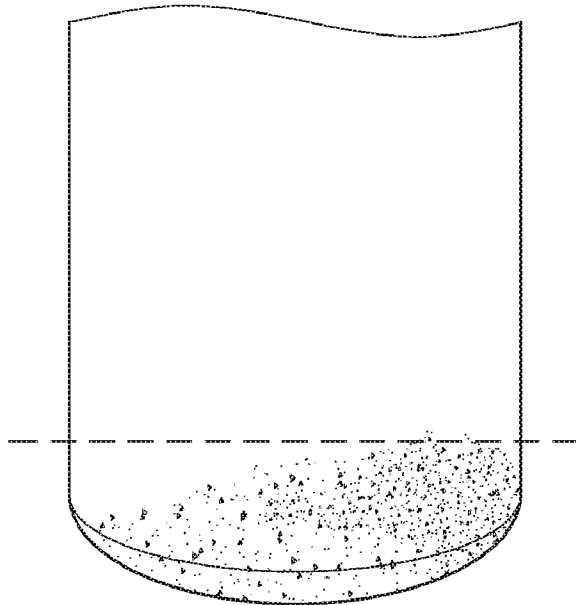

FIG. 4

4/5

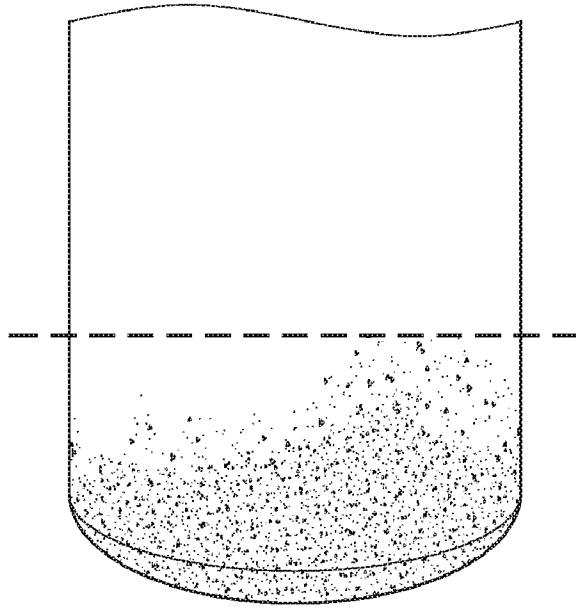

FIG. 5

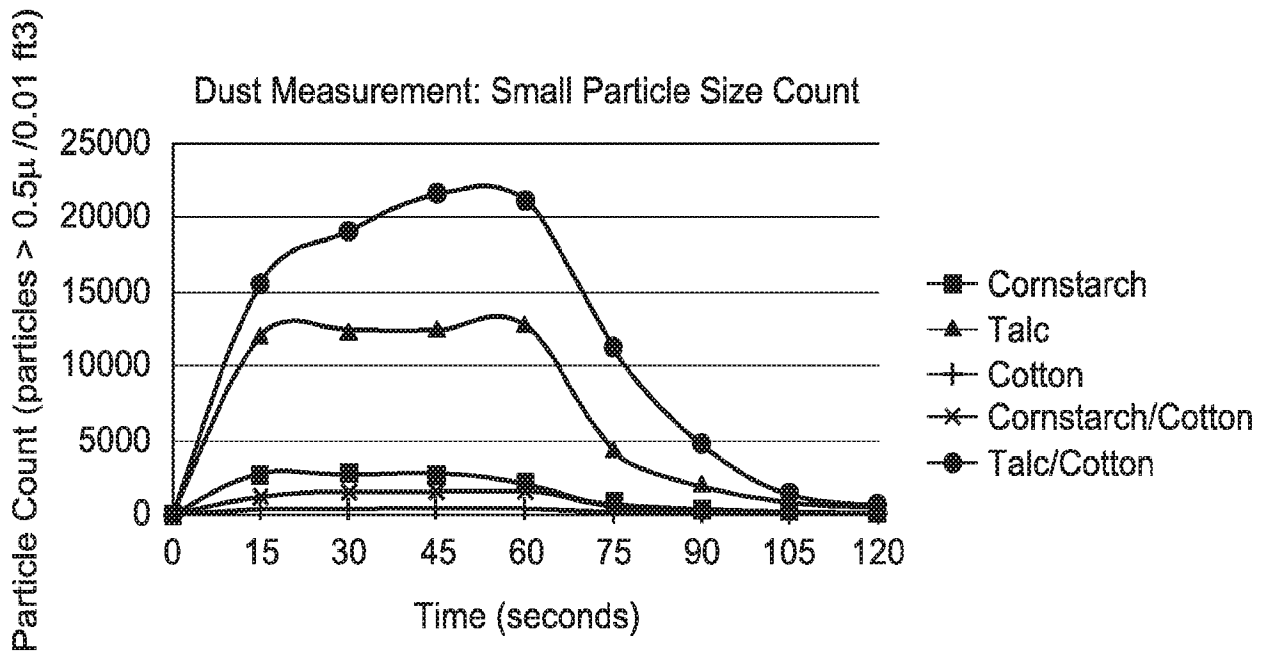

FIG. 6

5/5

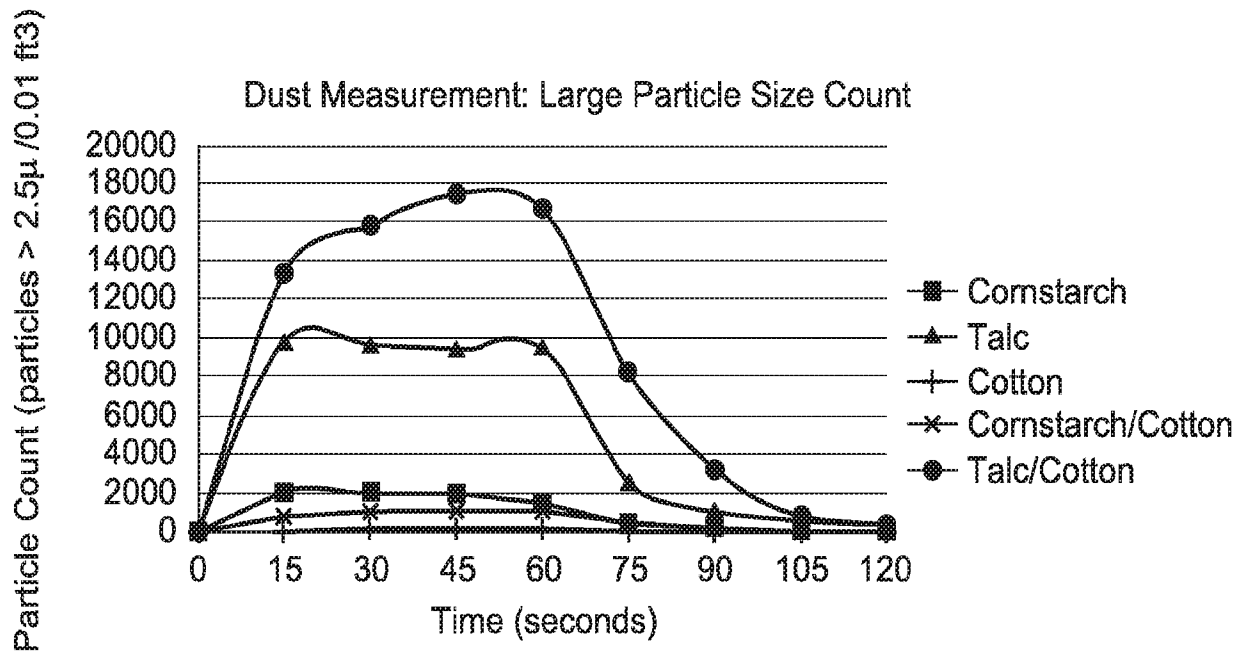

FIG. 7

INTERNATIONAL SEARCH REPORT

International application No
PCT/US2016/054328

A. CLASSIFICATION OF SUBJECT MATTER
 INV. A61K8/73 A61K8/19 A61K9/16 A61Q19/00
 ADD.
 According to International Patent Classification (IPC) or to both national classification and IPC

B. FIELDS SEARCHED
 Minimum documentation searched (classification system followed by classification symbols)
 A61K A61Q

Documentation searched other than minimum documentation to the extent that such documents are included in the fields searched

Electronic data base consulted during the international search (name of data base and, where practicable, search terms used)
 EPO-Internal

C. DOCUMENTS CONSIDERED TO BE RELEVANT

Category*	Citation of document, with indication, where appropriate, of the relevant passages	Relevant to claim No.
X	WO 2014/074578 A1 (JOHNSON & JOHNSON CONSUMER [US]) 15 May 2014 (2014-05-15) page 14, line 24 - page 16, line 6; tables 6,B	1-18
X	WO 2014/074583 A1 (JOHNSON & JOHNSON CONSUMER [US]) 15 May 2014 (2014-05-15) page 16, line 7; claims 1,13,15,18	1-18

Further documents are listed in the continuation of Box C.

See patent family annex.

* Special categories of cited documents :

- "A" document defining the general state of the art which is not considered to be of particular relevance
- "E" earlier application or patent but published on or after the international filing date
- "L" document which may throw doubts on priority claim(s) or which is cited to establish the publication date of another citation or other special reason (as specified)
- "O" document referring to an oral disclosure, use, exhibition or other means
- "P" document published prior to the international filing date but later than the priority date claimed

- "T" later document published after the international filing date or priority date and not in conflict with the application but cited to understand the principle or theory underlying the invention
- "X" document of particular relevance; the claimed invention cannot be considered novel or cannot be considered to involve an inventive step when the document is taken alone
- "Y" document of particular relevance; the claimed invention cannot be considered to involve an inventive step when the document is combined with one or more other such documents, such combination being obvious to a person skilled in the art
- "&" document member of the same patent family

Date of the actual completion of the international search

21 February 2017

Date of mailing of the international search report

03/03/2017

Name and mailing address of the ISA/

European Patent Office, P.B. 5818 Patentlaan 2
 NL - 2280 HV Rijswijk
 Tel. (+31-70) 340-2040,
 Fax: (+31-70) 340-3016

Authorized officer

Uhl, Martin

INTERNATIONAL SEARCH REPORT

Information on patent family members

International application No

PCT/US2016/054328

Patent document cited in search report	Publication date	Patent family member(s)	Publication date
WO 2014074578 A1	15-05-2014	CN 104780904 A	15-07-2015
		HK 1211842 A1	03-06-2016
		US 2014134217 A1	15-05-2014
		US 2014234384 A1	21-08-2014
		US 2015037383 A1	05-02-2015
		US 2016279047 A1	29-09-2016
		WO 2014074578 A1	15-05-2014

WO 2014074583 A1	15-05-2014	CN 104780903 A	15-07-2015
		HK 1211841 A1	03-06-2016
		US 2014134219 A1	15-05-2014
		WO 2014074583 A1	15-05-2014
