

(19)
(12)

(KR)
(A)

(51) 。 Int. Cl.7
B32B 15/08

(11)
(43)

10-2005-0005510
2005 01 13

(21) 10-2004-7019356

(22) 2004 11 29

2004 11 29

(86) PCT/GB2003/002229

(87)

WO 2003/101728

(86) 2003 05 22

(87)

2003 12 11

(30) 0212392.5

2002 05 29

(GB)

(71) ()

8188

(72)

17 0 2, , 42

(74)

:

(54)

1 2
, 가

1

(core)

5,778,813

6,050,208

가

(GB00/04198)

(foam form)

GB00/04198

(中空)

(form)

GB02/01565

가

1 2 ;

가

(rib)가

가

1 2

가

가

가

가

GB00/04198

GB02/01565

가

가

5,778,813
0.5mm 20mm

6,050,208

, 가
5,778,813
가

6,050,208

02019

03.2

(faceplates)

, 1mm

30mm

가

가,

1 2

; ;

가

가

가

- 1 1
- 2 1
- 3 1 A-A
- 4 1 B-B
- 5 2 1
- 6 4 A-A
- 7 4 B-B

1 가 (1) 5m 6m
 11m 12m (10) (2) (3) (4)
) (10) 4.5m (6) ; faring nose)(5) 가
 27m
 2, 3 4 (10) 5m 6m 10m
 12m (stiffened box girder) 625kN
 0.5mm 20mm (faceplate)(11,
 12) 6mm 가 (11, 12) (14),
 (11, 12) 가 15mm 200mm ; 160mm가
 (14) (11, 12) (14) (11, 12) 3MPa , 6M
 pa , 250Mpa (14) (11, 12) 1Mpa , 1.4kPa 7.2kPa
 가
 (10) , (11, 12) (13)
 (13) (13) , (14) (13)
 (15, 16) (14)가 (13) (10) , (15)가
) (16) (6) (10) (10) (6) (14)

(15) 0.5m 2m 11m (15)

(15) 10mm 100mm ; 50mm가 (15)
 (11, 12) 가
 (stub)(131) (13) (131)
 (10) (131)
 (13) (131)가 가 (11, 12) 가
 (13) (13)

(13) 가 (10) (11)
 가 (15, 16) 가 (14) (12)
 (ground off)

2 가 5, 56, 7 , 2, 3, 4
 (20) 3m 가 2
 6 가 (20) 3mm 10 가 , 2 4 60mm 4, 5,
 (26) () 가 27 (25)

가 (13) 가 ,
 가 (13) 가 ,
 (11, 12)

(57)

1.

1 2 ;

가

; ,

가

1 2

2.

1

3.

1 ,

4.
1 , 2 , 3

2

1

5.
4
2m

1

0.5m

6.

10mm 100mm

7.

8.

1 2

9.

1 2

10.

1 2

;

;

가 가

가

11.

12.

1

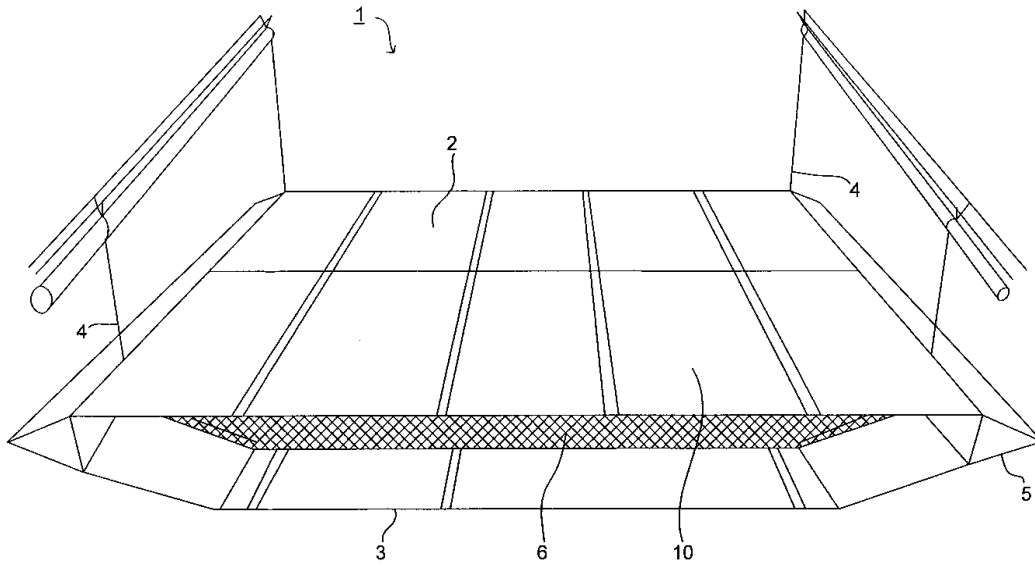

2

