

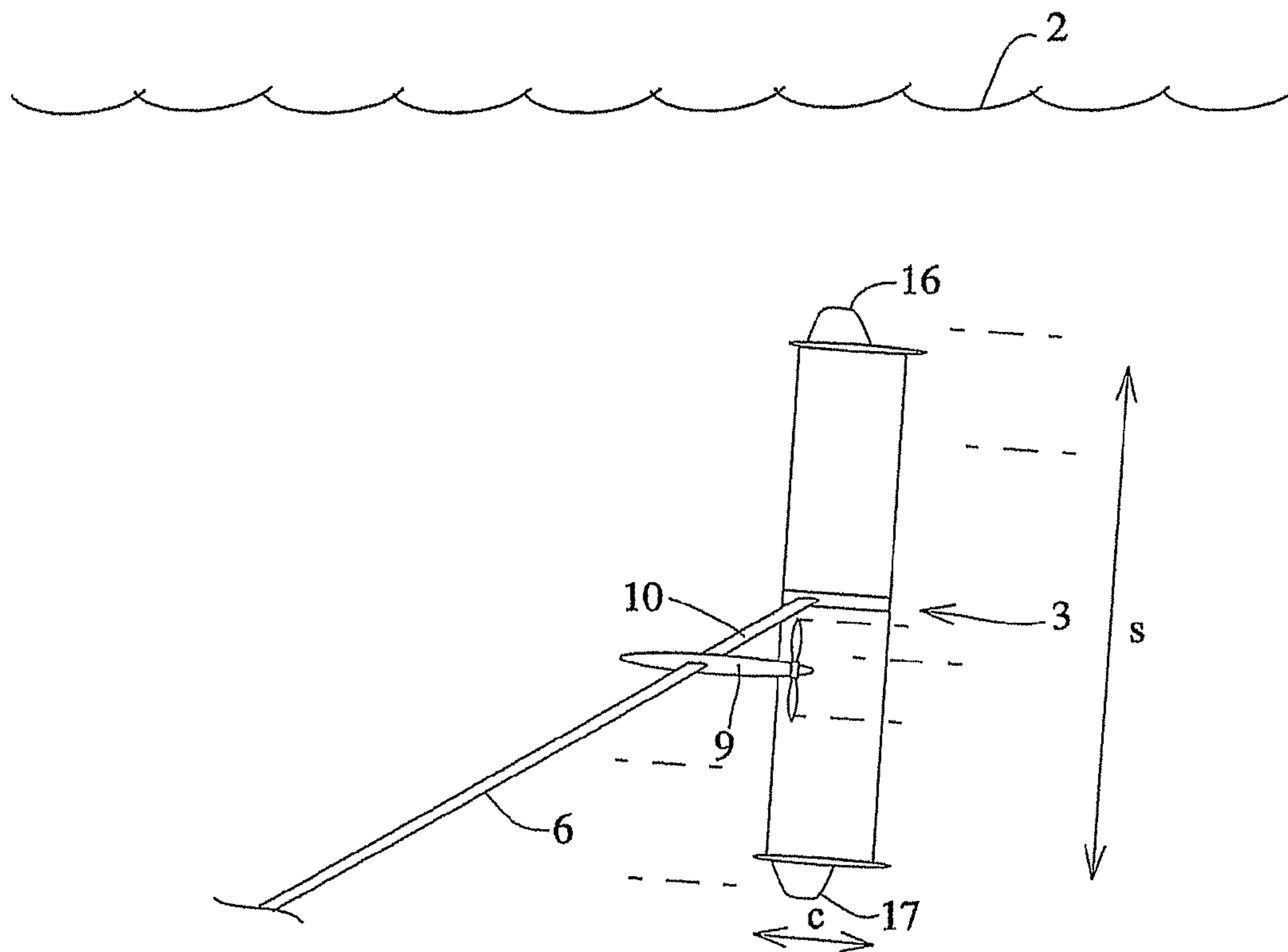

(86) Date de dépôt PCT/PCT Filing Date: 2007/01/31
 (87) Date publication PCT/PCT Publication Date: 2007/09/13
 (45) Date de délivrance/Issue Date: 2014/12/23
 (85) Entrée phase nationale/National Entry: 2008/07/15
 (86) N° demande PCT/PCT Application No.: EP 2007/050924
 (87) N° publication PCT/PCT Publication No.: 2007/101756
 (30) Priorité/Priority: 2006/02/02 (EP06101208.4)

(51) Cl.Int./Int.Cl. *F03B 17/06* (2006.01)
 (72) Inventeur/Inventor:
 LANDBERG, MAGNUS, SE
 (73) Propriétaire/Owner:
 MINESTO AB, SE
 (74) Agent: FETHERSTONHAUGH & CO.

(54) Titre : SYSTEME D'ENERGIE MAREMOTRICE
 (54) Title: TIDAL ENERGY SYSTEM



(57) **Abrégé/Abstract:**

The present invention relates to a submersible plant for producing energy. The submersible plant comprises at least one turbine (9) and is characterized in that said turbine (9) is mounted on a stream-driven vehicle (3) and in that said stream-driven vehicle is secured in a structure by means of at least one wire (6).

(12) INTERNATIONAL APPLICATION PUBLISHED UNDER THE PATENT COOPERATION TREATY (PCT)

(19) World Intellectual Property Organization
International Bureau



(43) International Publication Date
13 September 2007 (13.09.2007)

PCT

(10) International Publication Number
WO 2007/101756 A1

(51) International Patent Classification:
F03B 17/06 (2006.01)

(21) International Application Number:

PCT/EP2007/050924

(22) International Filing Date: 31 January 2007 (31.01.2007)

(25) Filing Language:

English

(26) Publication Language:

English

(30) Priority Data:

06101208.4 2 February 2006 (02.02.2006) EP

(71) Applicant (for all designated States except US): SAAB AB
[SE/SE]; S-581 88 Linköping (SE).

(72) Inventor; and

(75) Inventor/Applicant (for US only): LANDBERG, Magnus
[SE/SE]; S-587 29 Linköping (SE).

(74) Agent: ALBIHNS STOCKHOLM AB; P.O. Box 5581,
S-114 85 Stockholm (SE).

(81) Designated States (unless otherwise indicated, for every kind of national protection available): AE, AG, AL, AM, AT, AU, AZ, BA, BB, BG, BR, BW, BY, BZ, CA, CH, CN, CO, CR, CU, CZ, DE, DK, DM, DZ, EC, EE, EG, ES, FI, GB, GD, GE, GH, GM, GT, HN, HR, HU, ID, IL, IN, IS, JP, KE, KG, KM, KN, KP, KR, KZ, LA, LC, LK, LR, LS, LT, LU, LV, LY, MA, MD, MG, MK, MN, MW, MX, MY, MZ, NA, NG, NI, NO, NZ, OM, PG, PH, PL, PT, RO, RS, RU, SC, SD, SE, SG, SK, SL, SM, SV, SY, TJ, TM, TN, TR, TT, TZ, UA, UG, US, UZ, VC, VN, ZA, ZM, ZW.

(84) Designated States (unless otherwise indicated, for every kind of regional protection available): ARIPO (BW, GH, GM, KE, LS, MW, MZ, NA, SD, SL, SZ, TZ, UG, ZM, ZW), Eurasian (AM, AZ, BY, KG, KZ, MD, RU, TJ, TM), European (AT, BE, BG, CH, CY, CZ, DE, DK, EE, ES, FI, FR, GB, GR, HU, IE, IS, IT, LT, LU, LV, MC, NL, PL, PT, RO, SE, SI, SK, TR), OAPI (BF, BJ, CF, CG, CI, CM, GA, GN, GQ, GW, ML, MR, NE, SN, TD, TG).

Published:

— with international search report

For two-letter codes and other abbreviations, refer to the "Guidance Notes on Codes and Abbreviations" appearing at the beginning of each regular issue of the PCT Gazette.

(54) Title: TIDAL ENERGY SYSTEM

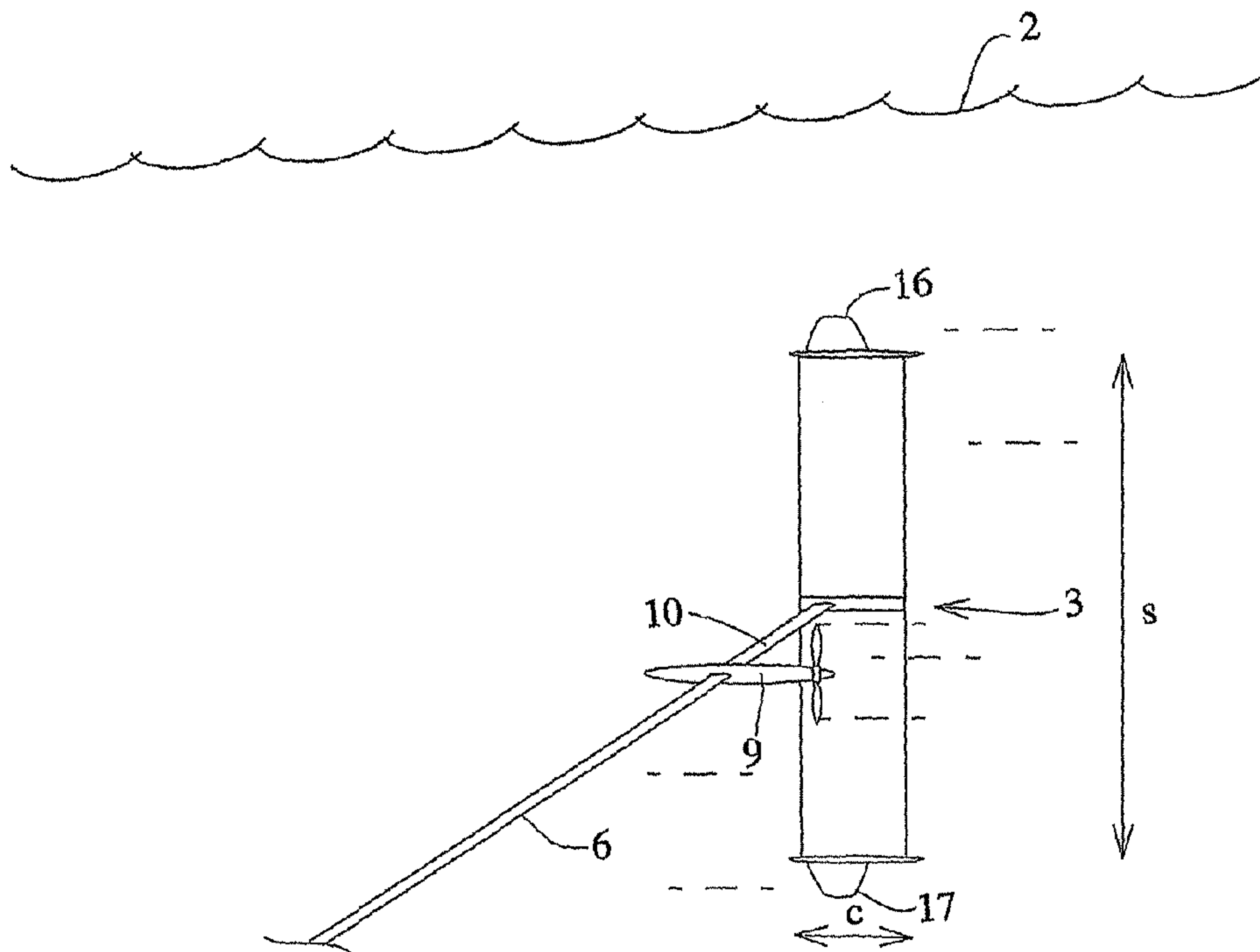

(57) Abstract: The present invention relates to a submersible plant for producing energy. The submersible plant comprises at least one turbine (9) and is characterized in that said turbine (9) is mounted on a stream-driven vehicle (3) and in that said stream-driven vehicle is secured in a structure by means of at least one wire (6).

WO 2007/101756 A1

TIDAL ENERGY SYSTEM

TECHNICAL AREA

The present invention relates to a submersible plant for producing energy
5 comprising at least one turbine.

DESCRIPTION OF PRIOR ART

One of the main global problems to be solved is how to supply energy to the
population of the world. The use of fossil fuels has to be decreased and
10 substituted with renewable sources of energy.

A significant percentage of the efforts to use renewable sources of energy have
been concentrated on wind powered systems. The wind powered generating
systems have a problem in that wind energy is inherently intermittent.

15 There exist today submersible plants for producing electricity from ocean
currents. Those plants are fastened in the sea bottom by means of wires and
comprise turbines arranged to be driven by tidal water.

20 However, the power generated from the submersible plants needs to be
increased without substantially increasing the costs in order to be
commercially attractive.

DESCRIPTION OF THE INVENTION

25 One object of some embodiments of the invention is to increase the power output from
submersible plants.

This has been achieved in some embodiments by means of a submersible plant for producing
energy comprising at least one turbine and characterized in that said turbine is

20615-1220

2

mounted on a stream-driven vehicle and in that said stream-driven vehicle is secured in a structure by means of at least one wire. The structure can be stationary, such as a mooring at the bottom of a sea, river, lake etc or a wind power plant or stationary submersible plant located in a sea or lake. The structure can also be movable, such as a ship.

The vehicle of the plant according to the present invention moves with a velocity which is many times (characteristically between 10-20 times) higher than the streaming velocity of the water. Thereby, the efficiency of the on board turbine arrangement is much higher than the efficiency of a stationary rotor arrangement.

The plant is preferably mounted in environments with well-defined, predictable streams with regard to direction and velocity such as in rivers, in tide affected areas and in ocean streams.

The plant in accordance with some embodiments of the invention enables environment friendly, rational and cost effective generation of energy, for example electrical energy, from relatively weak ocean currents and tide streams on sites close to the coast. The plant in accordance with some embodiments of the present invention can also be used offshore at relatively large depths, where few competing techniques are available.

In accordance with one preferred embodiment of the present invention the stream driven vehicle is a wing, ie a lifting body.

The vehicle is in accordance with another preferred embodiment substantially free swiveling at least in a pitch direction. The vehicle adapts to an optimum working point in the pitch direction. The vehicle is preferably also free

swiveling in a roll direction in relation to the turbine. Thereby the turbine will face the relative stream direction, ie the water stream will be forced upon the turbine from a direction perpendicular to a plane defined by the turbine blades.

5 In one preferred embodiment wherein the vehicle is free swiveling in accordance with the above, at least one of the turbines is mounted on the vehicle via a rod and a swivel coupling is mounted at one end of the rod for pivotally connecting either the turbine or the vehicle to the rod. The swivel coupling comprises for example a universal bearing.

10

In another preferred embodiment wherein the vehicle is free swiveling in accordance with the above, at least one of the turbines is directly mounted on the vehicle by means of a swivel coupling.

15 In yet another preferred embodiment of the invention the stream-driven vehicle is provided with steering means and a control unit is arranged to provide control signals to the steering means for steering the vehicle in a predetermined trajectory. The steering means can then include one or more control surfaces.

20

Further, the wire will preferably be stretched and accordingly the predetermined trajectory is formed in a spherical surface. In order to provide the stream-driving, the predetermined trajectory will at least partly cross the stream-direction.

25

In accordance with one embodiment of the invention, the turbine is operatively connected to a generator arranged to produce electrical energy. The generator can be operatively connected to an electrical cable arranged to distribute said electrical energy. The electrical cable is for example at least partly integrated

20615-1220

4

in the wire. However, if an electrical cable connecting to the vehicle is not desirable, the produced electrical energy can for example be used for electrolyzing the water and production of hydrogen gas directly at the vehicle.

According to one aspect of the present invention, there is provided a submersible plant for
5 producing electrical energy from a water stream, said plant comprising at least one turbine arrangement secured in a structure by means of a wire, wherein the turbine arrangement is mounted to a stream-driven vehicle that is formed by at least one wing and that can move freely within a range of the wire, said vehicle being provided with steering means and a control unit, wherein the control unit is arranged to provide control signals to the steering
10 means for steering the vehicle in a trajectory at least partly crossing the direction of the water stream, wherein said vehicle is capable of, when steered in said trajectory, being driven by the water stream with a velocity which is many times higher than the streaming velocity of the water.

According to another aspect of the present invention, there is provided a method for operating
15 a submersible plant as described herein, wherein the method comprises the step of: steering the vehicle in a trajectory at least partly crossing the direction of the water stream such as to allow the vehicle to be driven by the water stream with a velocity which is many times higher than the streaming velocity of the water.

BRIEF DESCRIPTION OF FIGURES

20 Fig. 1a shows an example of a submersible plant arrangement in accordance with a first example of the invention in a xy-plane, wherein x denotes a horizontal direction perpendicular to the stream direction and y denotes the vertical direction.

Fig. 1b shows the submersible plant arrangement of Fig. 1a in a yz-plane, wherein z denotes a horizontal stream direction.

25 Fig. 1c shows the submersible plant arrangement of Fig. 1a in a xz-plane.

Fig. 2 shows a first example of a stream driven vehicle of the submersible plant of fig 1.

20615-1220

4a

Fig. 3 shows in cross-section an example of a wire of the submersible plant of fig 1.

Fig 4 shows an example of a mounting of a turbine to the vehicle of the submersible plant of fig 1.

Fig. 5 shows an example of a control unit of the submersible plant of fig 1.

5 Fig. 6a shows an example of a submersible plant arrangement in accordance with a second example of the invention in a xy-plane, wherein x denotes a

horizontal direction perpendicular to the stream direction and y denotes the vertical direction.

Fig. 6b shows the submersible plant arrangement of Fig. 6a in a yz -plane,
5 wherein z denotes a horizontal stream direction.

Fig. 6c shows the submersible plant arrangement of Fig. 6a in a xz -plane.

Fig. 7 shows a second example of a stream driven vehicle of the submersible
10 plant of fig 1.

PREFERRED EMBODIMENTS

In figs 1a, 1b and 1c, a submersible plant 1 is arranged under the water surface
2 of for example the sea. The plant 1 comprises a stream-driven vehicle 3
15 secured in a mooring 4 at the bottom 5 of the sea by means of a wire 6. The
length of the wire 6 is for example 50-200 meters. In fig 1a, z defines the
horizontal stream direction, x a horizontal direction perpendicular to the
stream direction and y defines the vertical direction. The vehicle can move
freely within a range of the wire. However, in figs 1a, 1b and 1c, the vehicle
20 follows a never-ending trajectory 7 formed as the digit eight in a spherical
surface with a bending radius equal to the length of the wire. The trajectory is
preferably chosen such that the vehicle is always is beneath the sea surface.
For example, the trajectory can be chosen such that the wire always ends 10-
20 meters beneath the sea surface. Thereby the vehicle is not subjected to the
25 turbulences usually present close to the surface and the risk of turbine
cavitation can be minimized. The advantage of having a trajectory formed as
the digit eight is that then the wire will not be twisted and accordingly, there is
no need for connecting the wire 6 to the mooring 4 by means of a swiveling
device

In fig 2 the stream-driven vehicle 3 is a wing, ie a lifting body. The wing has for example a wing span s of about 15 meters and a width (cord) c which is for example 2-3 meters. The thickness of the wing may be 10-20% of the width.

5 The wing is preferably formed by a spar supporting a surface structure. The spar is in one example made of a carbon fibre composite material. The surface structure is for example made of a glass fibre composite material.

A turbine arrangement 9, in the illustrated embodiment comprising one
10 turbine, is mounted to the vehicle structure by means of a rod 10. The turbine 9 and rod 10 can be made of a metal or compound of metals, for example stainless steel. In one example, the turbine 9 has adjustable blades and in another example, the blades of the turbine 9 are fixedly mounted. The diameter of the turbine is for example 1 to 1.5 meters. The wire 6 is secured in
15 the turbine 9. The turbine 9 is operatively connected to a generator (not shown) arranged to produce electrical energy distributed via an electrical cable integrated within or secured to the wire. In one example, the generator is speed controlled and in another example, the generator is not speed controlled. The electricity is distributed further from the mooring 4 via a distribution network.

20

The density of the vehicle 3 with its turbine 9, rod 10 and wire 6 is preferably somewhat lower than the density of water.

In fig 3 the wire 6 comprises two supporting twisted cables 11a, 11b for
25 example made of a carbon fiber material and the electrical cable 12. The wire further comprises an additional electrical low voltage or optical cable 13 for data communication with the vehicle 3. The supporting cables 11a, 11b, electrical cable 12 and low voltage or optical cable 13 are enclosed in a cover 14, for example made of a rubber material or plastic.

The vehicle 3 is preferably powered only by the stream. However, in certain situations, for example when an error condition has appeared, the electrical generator can be used as an electrical engine powered by one or several
5 batteries (not shown) mounted at the vehicle. Then, the generator/engine can drive the vehicle to the sea surface for transportation to a service site. This of course presumes that the vehicle first has been released from the wire. The generator can be used as an engine also for other purposes, for example for driving the vehicle to a parking location at the sea bottom.

10

In fig 4, the rod 10 is mounted to the vehicle 3 by means of a bearing arrangement 8 so that the vehicle is free swiveling at least in pitch direction but preferably also in roll direction. Preferably, the relationship between the turbine and the vehicle is fixed in yaw direction. The fact that the vehicle is
15 free swiveling in relation to the turbine secures that the turbine arrangement always substantially faces the relative stream direction, ie the stream direction is perpendicular to a plane defined by the turbine blades. In fig 4, the bearing arrangement is a universal bearing. The universal bearing provides for the free swiveling feature in pitch and roll direction. In the example illustrated in fig 4,
20 the turbine is fixedly mounted to the rod, or integrated therewith while the other end of the rod facing the vehicle is mounted to the vehicle by means of the bearing arrangement 8. However, in an alternative example (not shown) the bearing arrangement 8 is mounted at the end of the rod facing the turbine. In yet another example (not shown), the turbine is fixedly mounted to the rod
25 or integrated therewith and the other end of the rod facing the vehicle is fixedly mounted to the vehicle or integrated therewith.

In fig 5, a control system 15 mounted on the vehicle is arranged to guide the vehicle in the predetermined trajectory 7 without exceeding the structural load

limitations on the vehicle and turbine and electrical load limitations on the turbine. Other functional requirements of the control system 15 are to stabilize the vehicle 3 and optimize or control the power output of the device in the never-ending trajectory 7.

5

The control system 15 has in the shown example four input signals for guidance and tracking. The first input signal, namely current tilt angle α (see fig 1b), and the second input signal, namely current rotational angle β (see fig 1c), are provided from angle detecting devices (not shown) mounted at the mooring 4 of the wire 6 and fed for example via the previously described electrical cable 13 in the wire 6 to the control system 15. The first, tilt angle signal α defines the angle between the wire 6 and the horizontal plane. The second, rotational angle signal β defines the angle between the wire 6 and the horizontal stream direction. Two angle measuring arrangements are further mounted in the vehicle bearing arrangement 8. These two angle measuring devices are arranged to provide a third input signal to the control system indicating a roll angle between the vehicle 3 and rod 10 and to provide a fourth input signal indicating a pitch angle between the vehicle 3 and the rod 10. Further sensor data can for example be provided from an inertial measurement unit at the vehicle for refining the computations of the control system 15. The further sensor data can also relate to the water depth.

The tilt angle data α , rotational angle data β , roll angle data and pitch angle data are processed by the control system and a command angle is outputted for a first control surface 16 (fig 2) of the vehicle 3 and a command angle for the second control surface 17 of the vehicle 3. In processing, values are calculated for pitch and yaw movements required by the vehicle in order to follow the predetermined trajectory. The control system then provides in a second step a command angle for each servo actuator (not shown) mounted on its

25

corresponding control surface 16, 17. The hydrodynamic forces on the control surfaces then cause the vehicle and turbine to yaw and roll in order to follow the predetermined trajectory. The algorithms for calculating command angles for the first and second surfaces 16, 17 do not form part of the present
5 invention. It would constitute normal operations to a person skilled in the art to provide an algorithm for guiding a vehicle in accordance with the above in a predetermined trajectory under given physical conditions. However, it can be said that the force and tension in the wire is very high when the vehicle operates in its trajectory. Accordingly, in determining the command angles for
10 the control surfaces 16, 17, the wire 6 can be approximated as a linear rod.

In figs 6a, 6b, 6c, an example of an alternative never ending trajectory 7 of the vehicle 3 is shown in the same coordinate system as in fig 1. The trajectory illustrated in figs 6a, 6b and 6c is formed as an oval. The illustrated never
15 ending trajectory requires a swiveling device at the mooring 4 in order to avoid twisting the wire.

In fig 7 the vehicle is provided with two additional turbines 18, 19, one at each end of the vehicle. The turbines are mounted to the vehicle by means of a
20 bearing allowing the turbines to be free swiveling in a pitch direction. An electrical generator arranged to produce electrical energy is connected to each turbine. A cable connects each additional turbine generator to the electrical cable 12 of the wire 6 for further distribution.

25 The vehicle is in the illustrated examples a wing. However, the invention is not limited to a vehicle in the form of a wing. For example, the vehicle can be formed by two or more wings arranged on top of each other and separated by means of spacer elements.

20615-1220

10

CLAIMS:

1. A submersible plant for producing electrical energy from a water stream,
said plant comprising at least one turbine arrangement secured in a structure by means of a wire,
5 wherein the turbine arrangement is mounted to a stream-driven vehicle that is formed by at least one wing and that can move freely within a range of the wire,
said vehicle being provided with steering means and a control unit, wherein the control unit is arranged to provide control signals to the steering means for steering the vehicle in a trajectory at least partly crossing the direction of the water stream,
10 wherein said vehicle is capable of, when steered in said trajectory, being driven by the water stream with a velocity which is many times higher than the streaming velocity of the water.
2. A submersible plant according to claim 1,
wherein it comprises means for providing input signals to the control unit
15 regarding a current tilt angle α , i.e. the angle defined between the wire and a horizontal plane, and a current rotational angle β , i.e. the angle defined between the wire and the horizontal stream direction.
3. A submersible plant according to claim 1 or 2,
wherein the trajectory is a never ending trajectory.
- 20 4. A submersible plant according to claim 3,
wherein the trajectory is formed as the digit 8.
5. A submersible plant according to any one of claims 1 to 4,

20615-1220

11

wherein the trajectory is formed in a spherical surface that has a bending radius substantially equal to the length of the wire.

6. A submersible plant according to any one of claims 1 to 5,

5 wherein a major part of the trajectory is directed substantially perpendicular to the direction of the water stream such that a varying rotational angle β is obtained between the wire and the horizontal direction of the water stream when the vehicle operates in its trajectory.

7. A submersible plant according to any one of claims 1 to 6,

10 wherein the at least one turbine arrangement comprises a turbine operatively connected to a generator arranged to produce electrical energy.

8. A submersible plant according to any one of claims 1 to 7, wherein said steering means includes at least one control surface.

9. A submersible plant according to claim 7, wherein the generator is operatively connected to an electrical cable arranged to distribute said electrical energy.

15 10. A submersible plant according to claim 9, wherein said electrical cable is at least partly integrated in the wire.

11. A method for operating a submersible plant according to claim 1,

wherein the method comprises the step of:

20 - steering the vehicle in a trajectory at least partly crossing the direction of the water stream such as to allow the vehicle to be driven by the water stream with a velocity which is many times higher than the streaming velocity of the water.

12. The method according to claim 11,

further comprising the step of:

20615-1220

12

- providing control signals to the steering means of the vehicle using the control unit.

13. The method according to claim 11 or 12,

further comprising the step of:

5 - providing input signals to the control unit regarding a current tilt angle α , i.e. the angle defined between the wire and a horizontal plane, and a current rotational angle β , i.e. the angle defined between the wire and the horizontal stream direction.

14. The method according to any one of claims 11-13,

wherein the trajectory is a never ending trajectory.

10 15. The method according to claim 14,

wherein the trajectory is formed as the digit 8.

16. The method according to any one of claims 11-15,

wherein the trajectory is formed in a spherical surface that has a bending radius substantially equal to the length of the wire.

15 17. The method according to any one of claims 11-16,

further comprising the step of:

- steering the vehicle in a direction substantially perpendicular to the direction of the water stream such that a varying rotational angle β is obtained between the wire and the horizontal stream direction during operation.

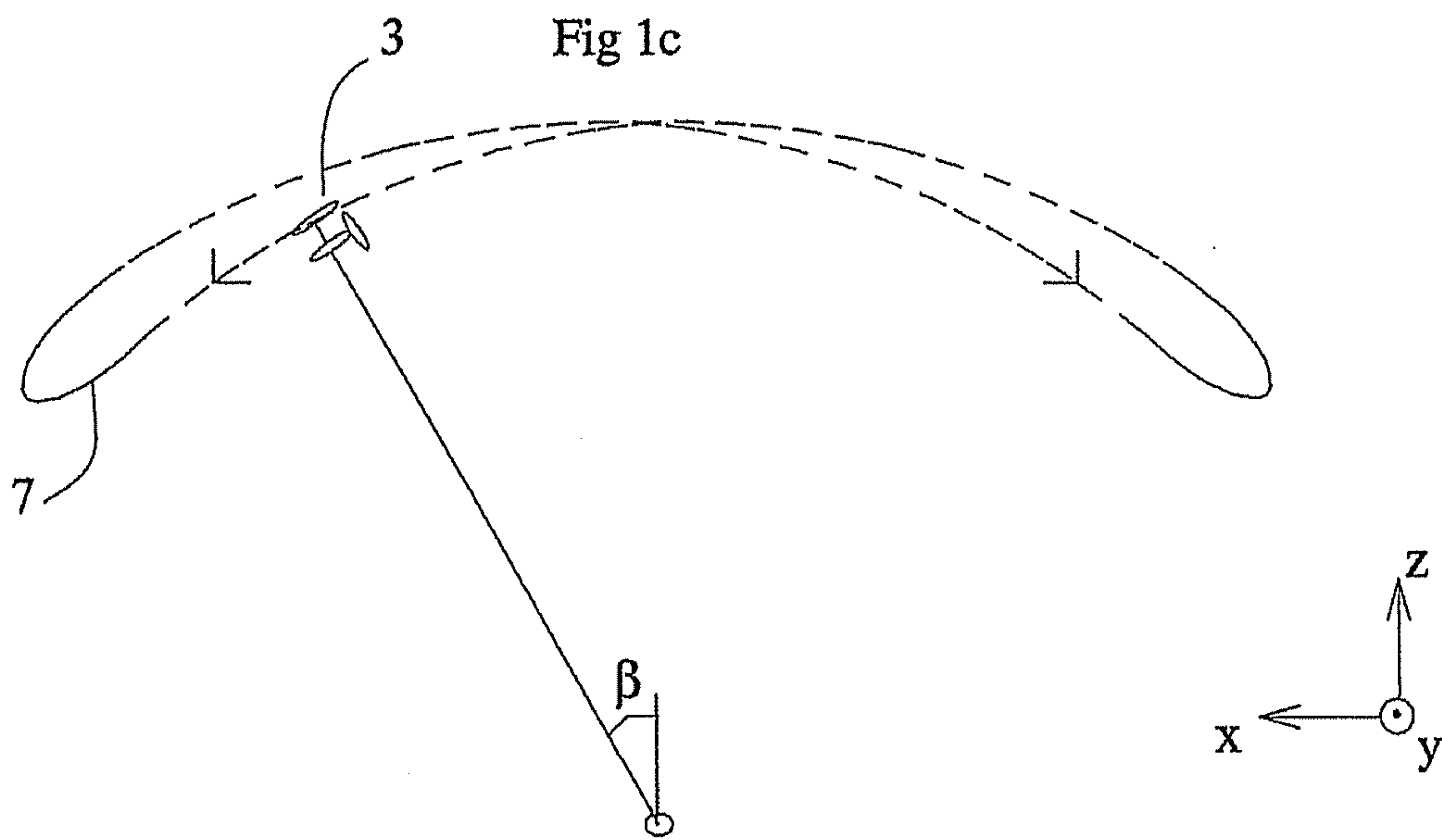
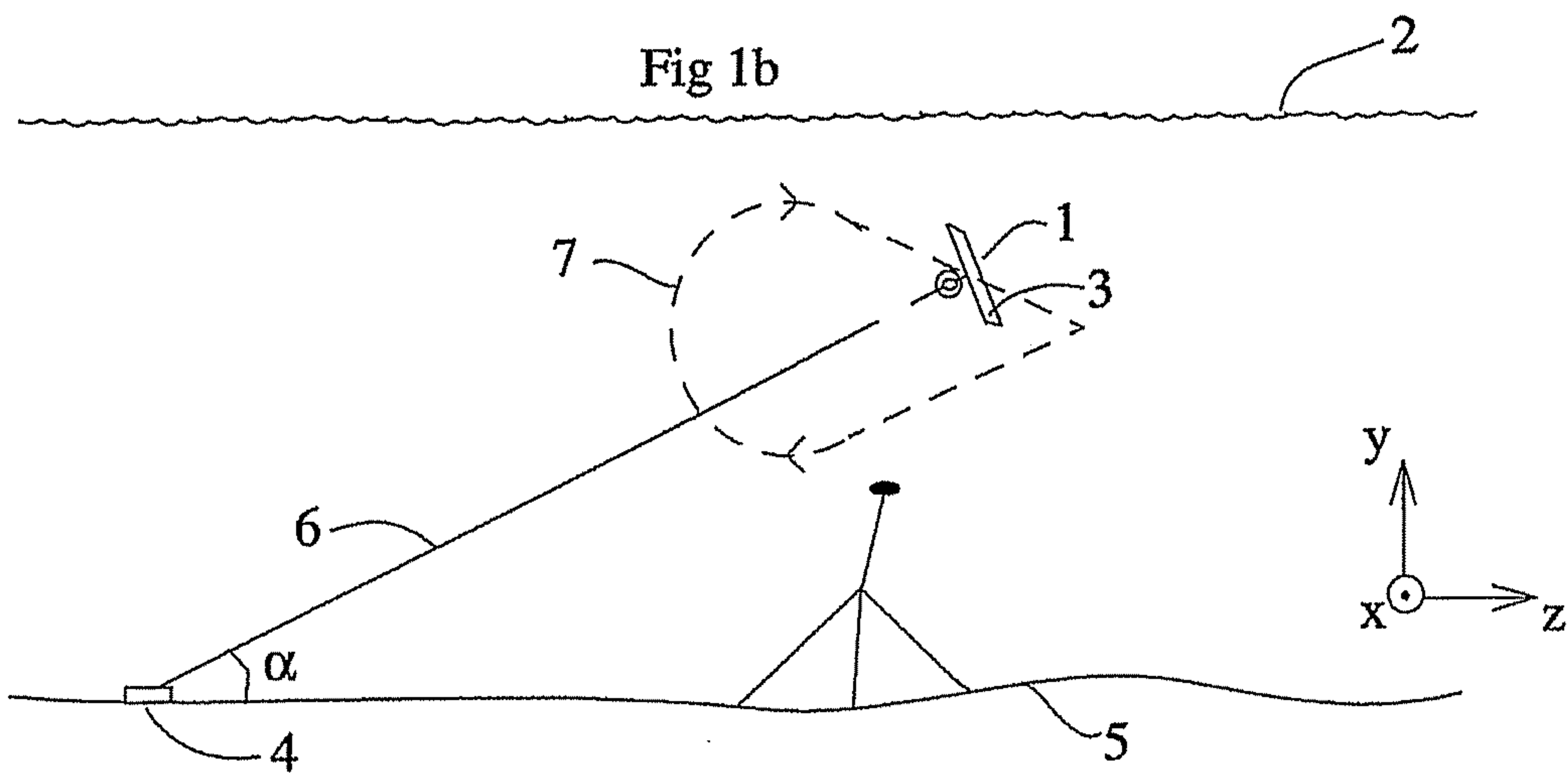
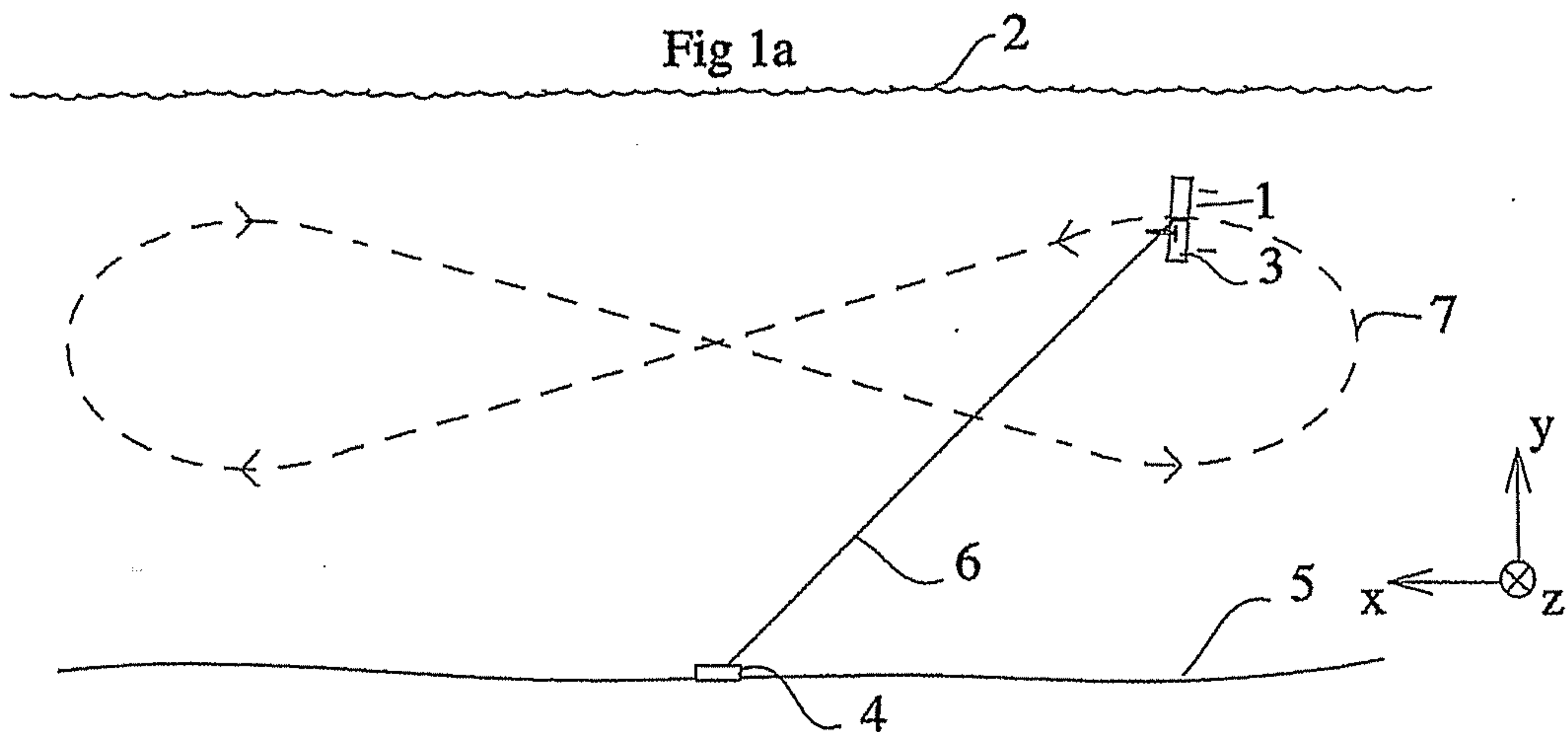

Fig 2

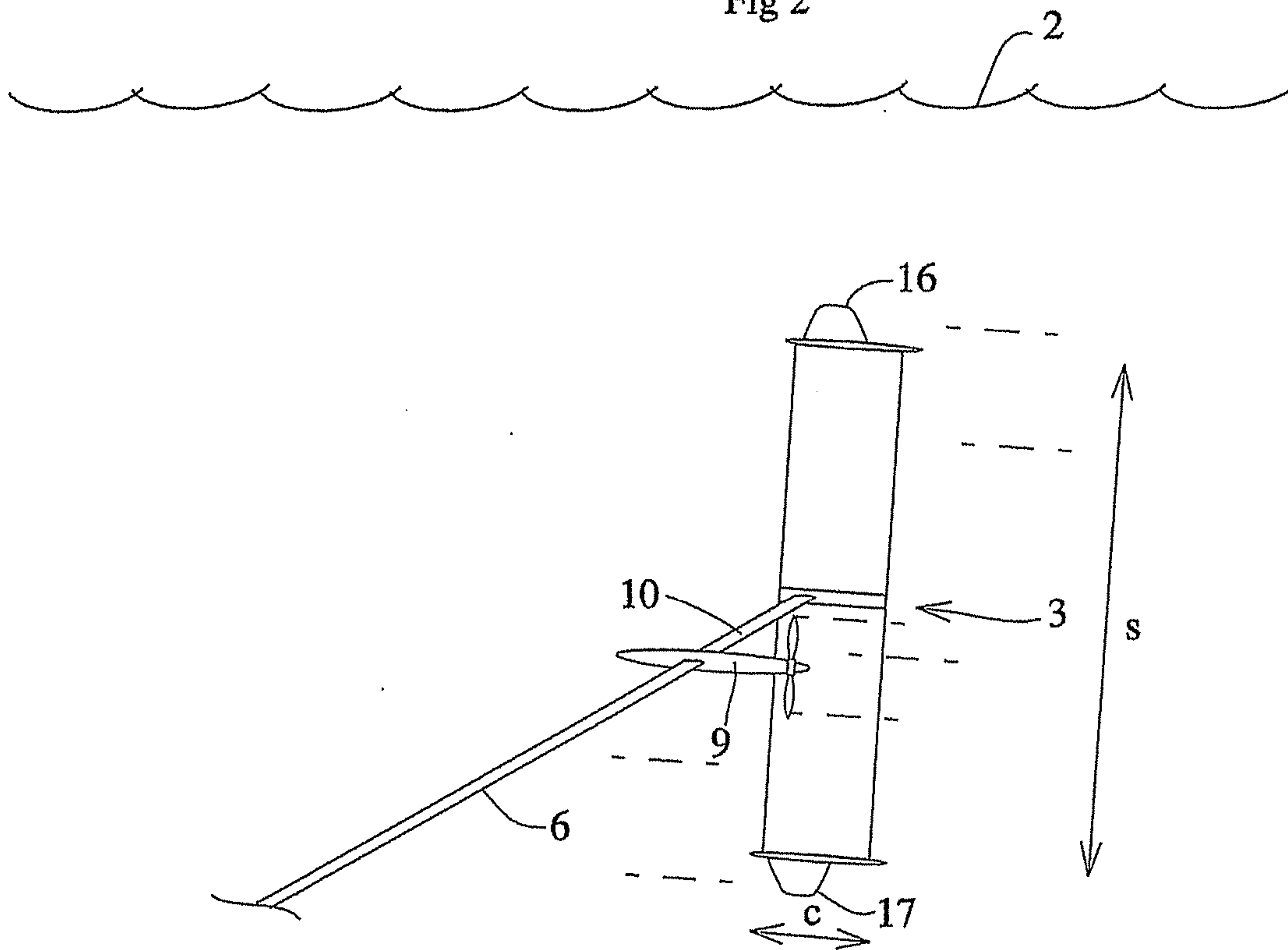

Fig 3

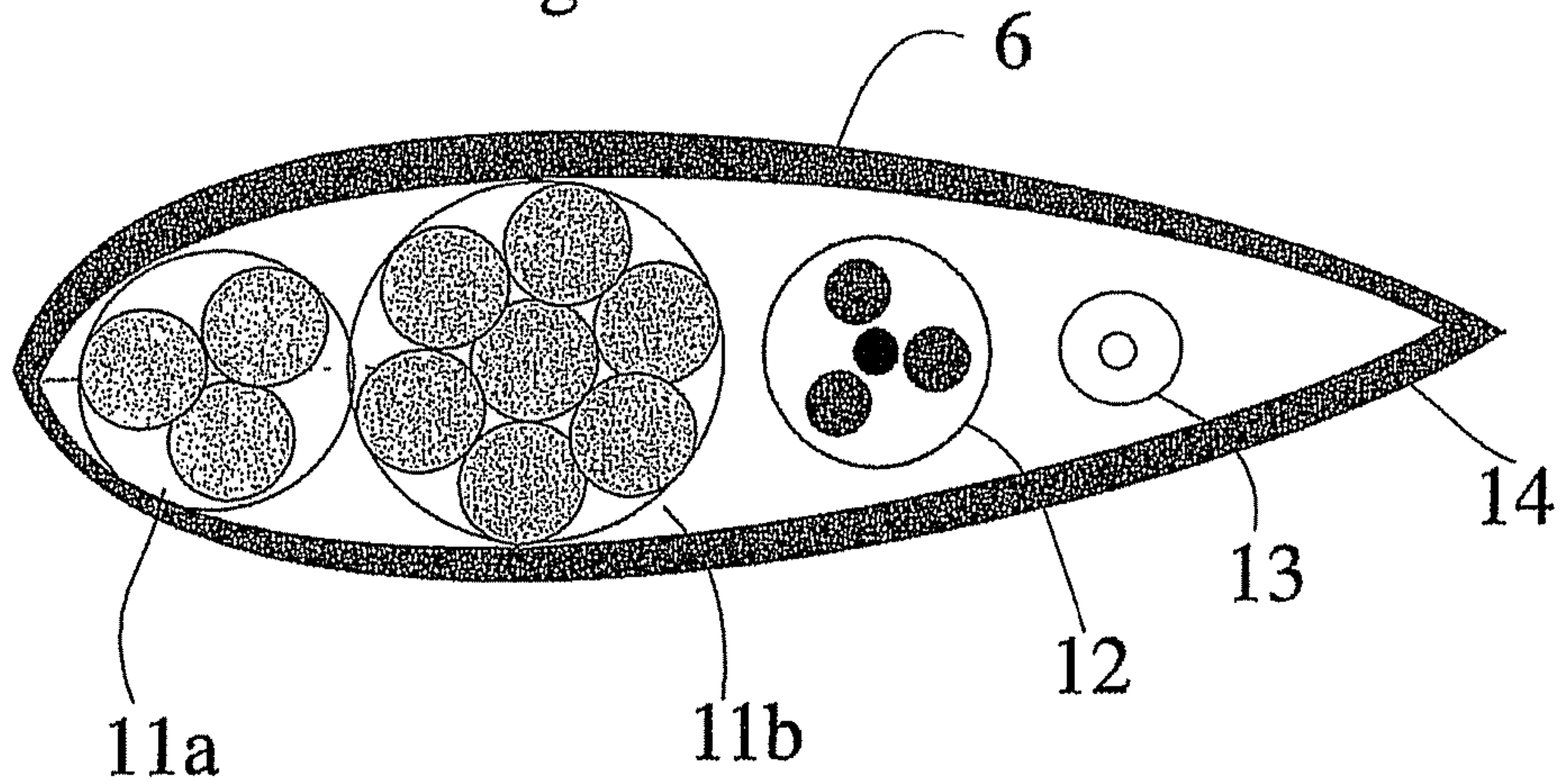

Fig 4

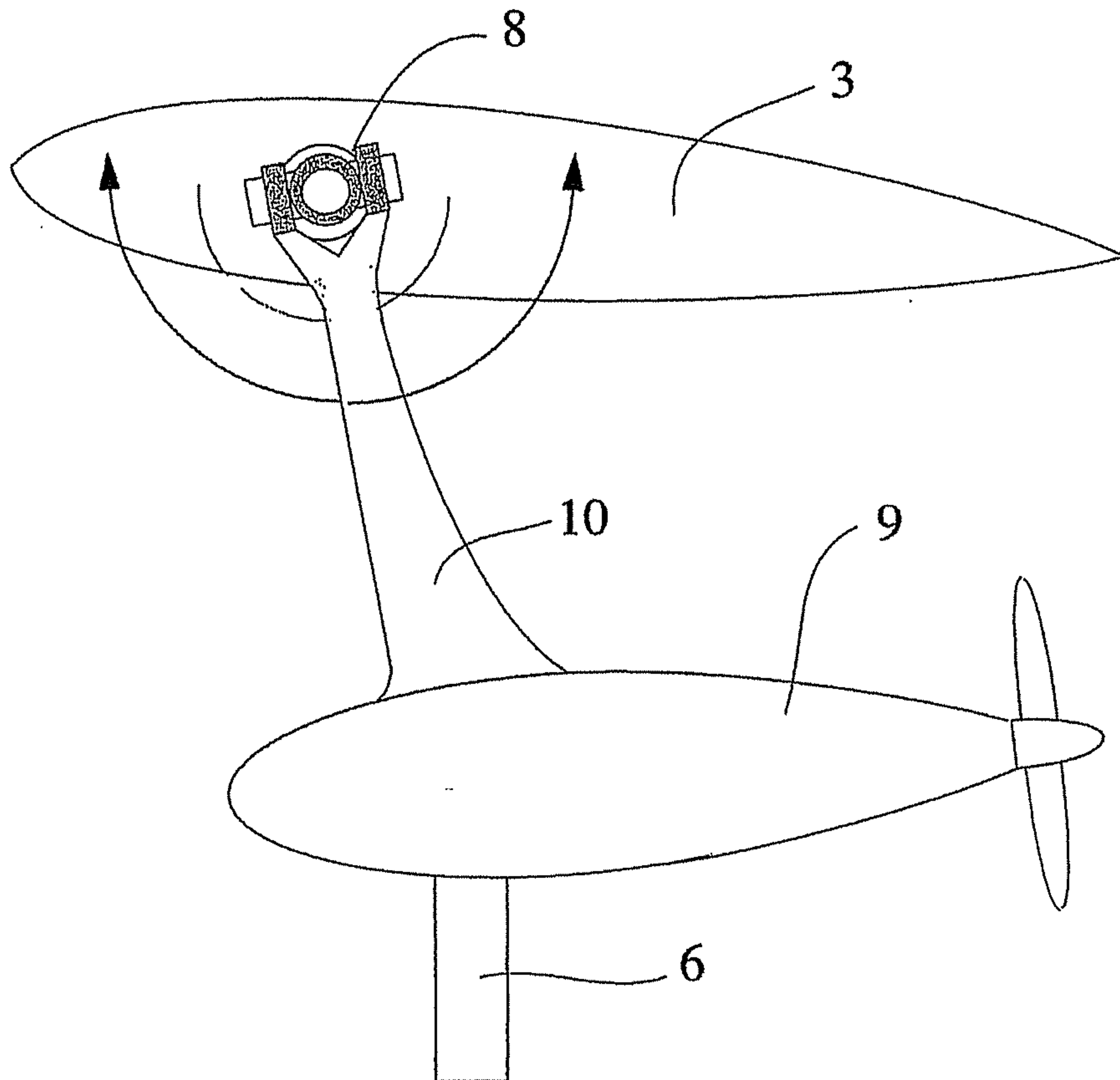

Fig 5

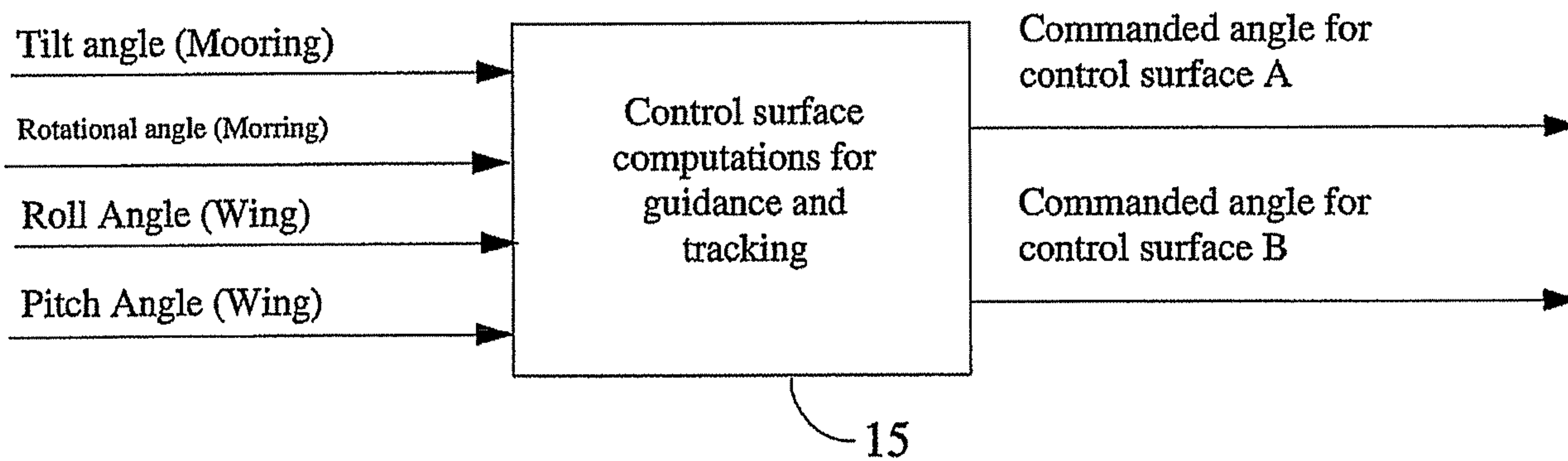

Fig 6a

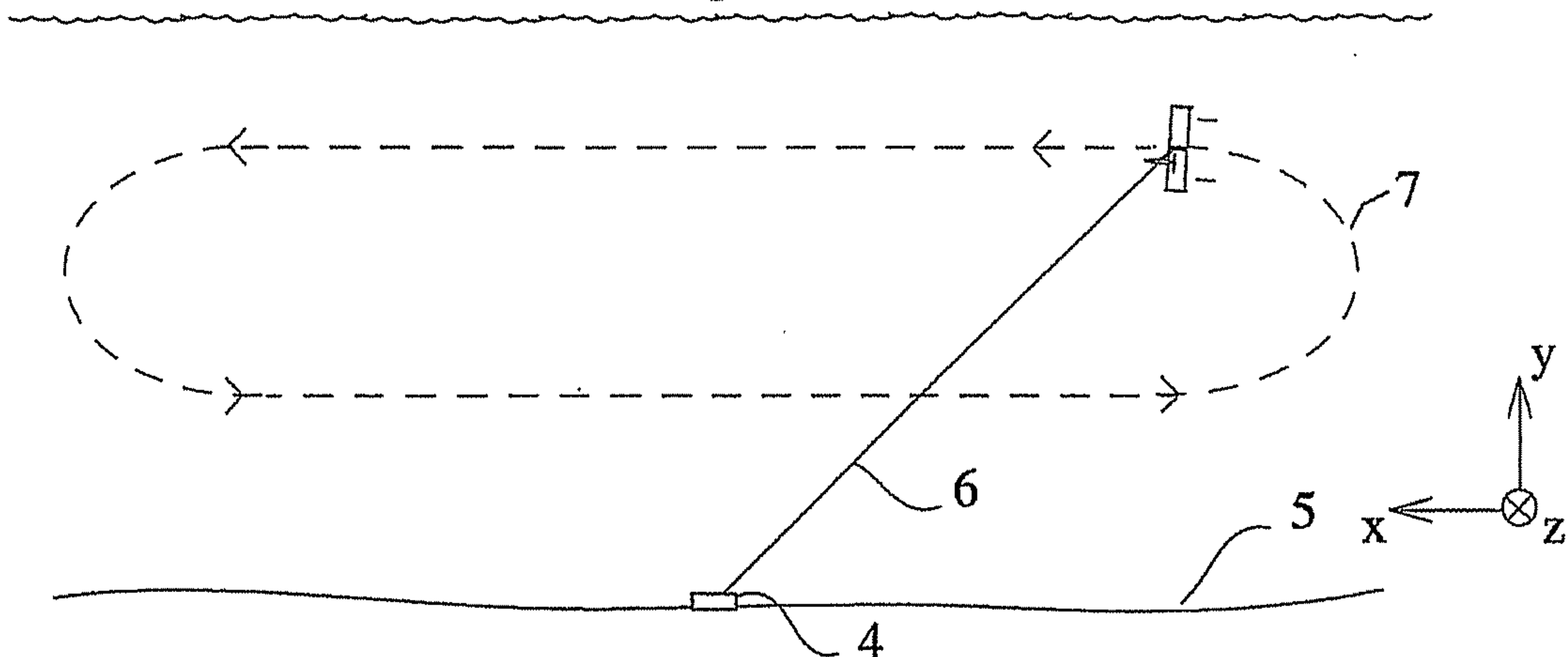

Fig 6b

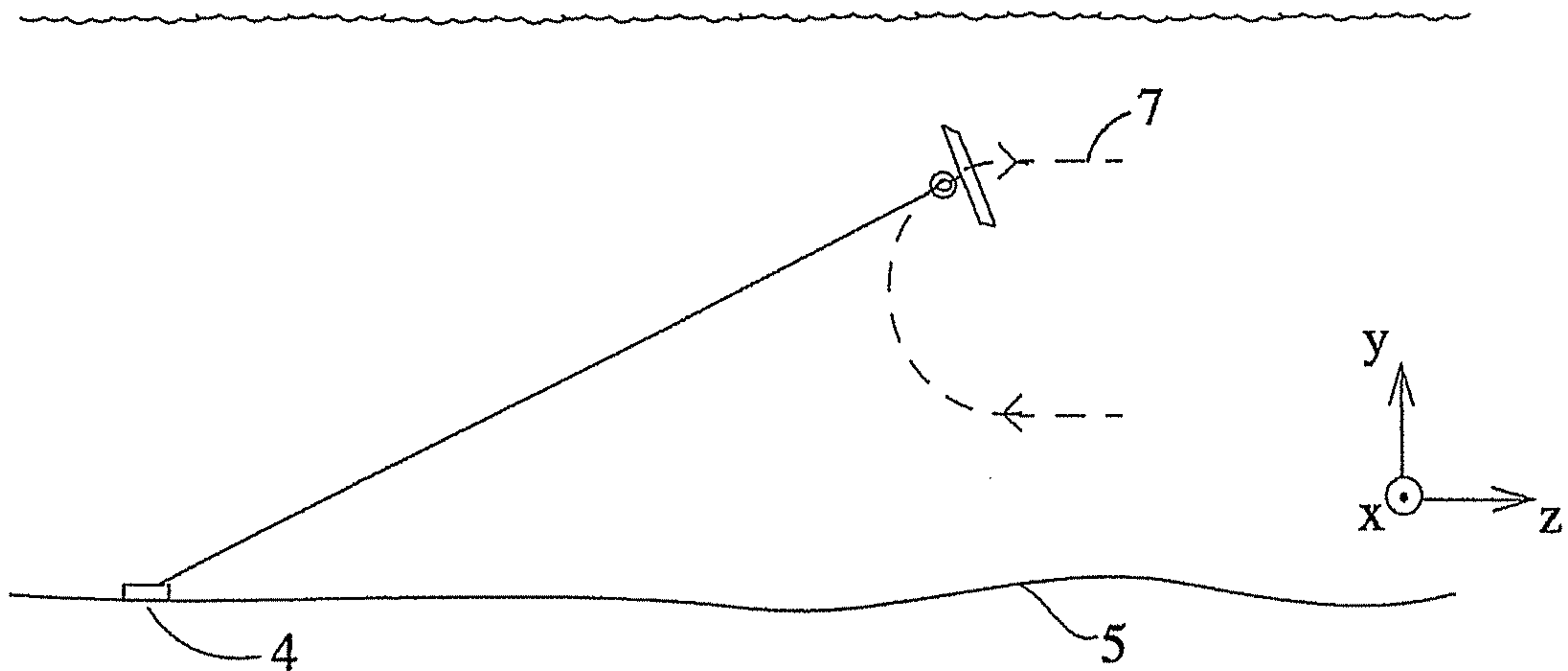

Fig 6c

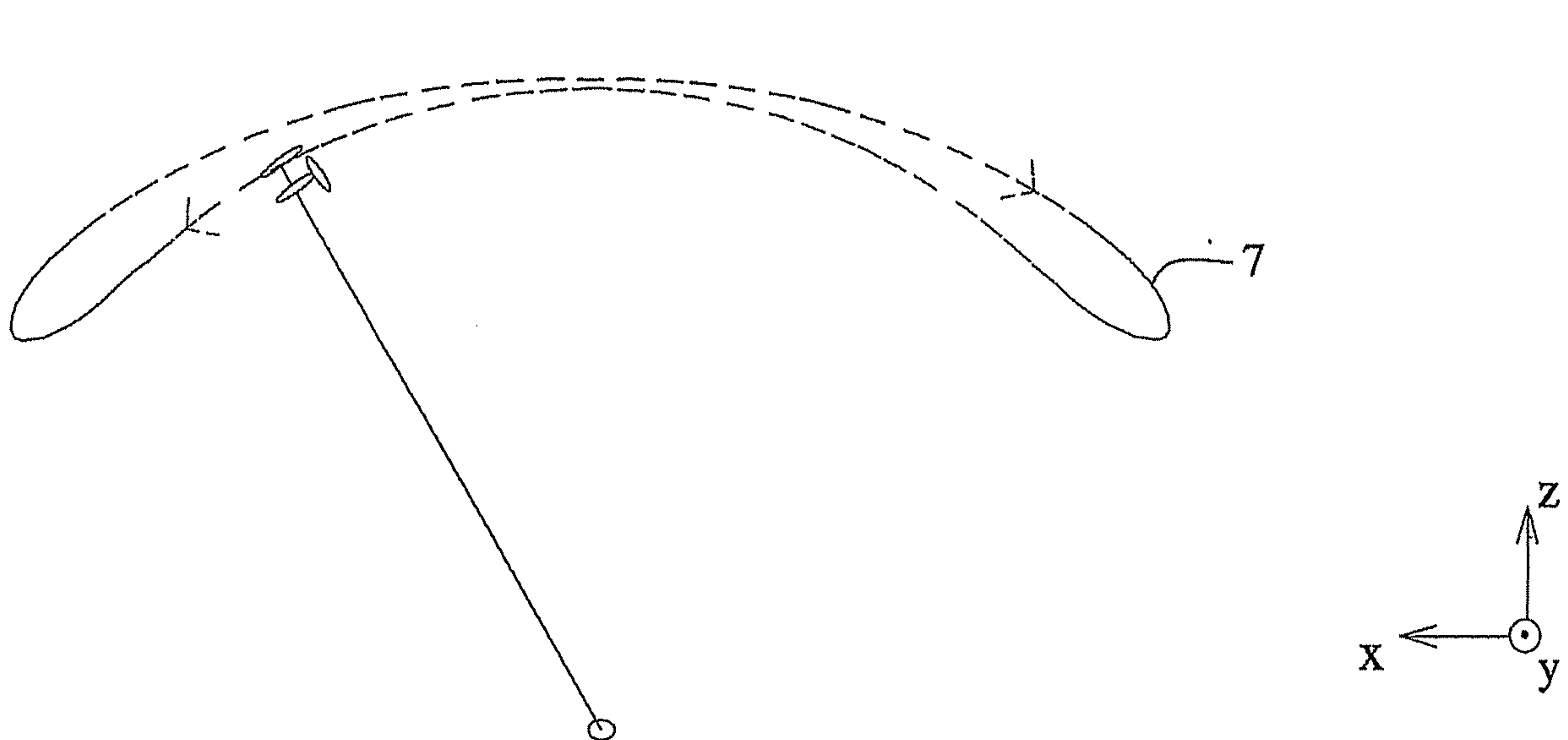

Fig 7

