

(19)



(11)

EP 4 082 402 B1

(12)

EUROPEAN PATENT SPECIFICATION

(45) Date of publication and mention of the grant of the patent:
19.02.2025 Bulletin 2025/08

(51) International Patent Classification (IPC):
A47F 3/04^(2006.01) F25D 17/08^(2006.01)

(21) Application number: **19957587.9**

(52) Cooperative Patent Classification (CPC):
A47F 3/0413

(22) Date of filing: **26.12.2019**

(86) International application number:
PCT/JP2019/051174

(87) International publication number:
WO 2021/130973 (01.07.2021 Gazette 2021/26)

(54) **REFRIGERATED SHOWCASE**

GEKÜHLTER SCHAUKASTEN

VITRINE RÉFRIGÉRÉE

(84) Designated Contracting States:
AL AT BE BG CH CY CZ DE DK EE ES FI FR GB GR HR HU IE IS IT LI LT LU LV MC MK MT NL NO PL PT RO RS SE SI SK SM TR

(74) Representative: **Vossius & Partner**
Patentanwälte Rechtsanwälte mbB
Siebertstraße 3
81675 München (DE)

(43) Date of publication of application:
02.11.2022 Bulletin 2022/44

(56) References cited:
EP-A1- 2 491 828 JP-A- 2000 116 535
JP-A- 2001 258 690 JP-A- 2002 272 570
JP-A- 2007 330 463 JP-A- 2013 194 987
JP-A- H08 121 924 JP-A- H1 151 533
JP-A- S55 131 671 JP-A- S58 110 977
JP-A- S60 218 566 JP-A- S63 113 282
JP-U- S4 885 248 JP-U- S53 165 260
JP-U- S53 165 260 JP-U- S6 065 578
US-A- 4 750 335

(73) Proprietor: **Recette9 Inc.**
Tokyo 107-6102 (JP)

(72) Inventors:
• **OTSUKA, Sakiko**
Tokyo 107-6102 (JP)
• **HIDAKA, Mikio**
Tokyo 107-6102 (JP)

EP 4 082 402 B1

Note: Within nine months of the publication of the mention of the grant of the European patent in the European Patent Bulletin, any person may give notice to the European Patent Office of opposition to that patent, in accordance with the Implementing Regulations. Notice of opposition shall not be deemed to have been filed until the opposition fee has been paid. (Art. 99(1) European Patent Convention).

Description

Application Publication No. 2004-340411

TECHNICAL FIELD

SUMMARY OF THE INVENTION

[0001] This invention relates to a refrigerated showcase with which foodstuffs to be refrigerated, such as cakes, fresh sweets, meats and seafoods, for instance, are displayed.

5 PROBLEMS TO BE SOLVED BY THE INVENTION

[0007] An object of the present invention is to provide a refrigerated showcase comprising a display chamber in which foodstuffs are displayed, a mounting lateral surface which is formed in the display chamber and constitutes a surface on the side where the foodstuffs are placed, and a vent which is positioned directly above the mounting lateral surface and from which refrigerated air is vented, whereby the refrigerated showcase makes it possible to keep the quality of the foodstuffs satisfactory and to achieve satisfactory energy efficiency, without the need for any complicated structure.

BACKGROUND ARTS

10

[0002] As one well-known refrigerated showcase, a patent document 1 below discloses a refrigerated showcase comprising a display chamber in which foodstuffs to be refrigerated are displayed, and a transparent cover which covers at least the front side of the display chamber, wherein the displayed foodstuffs are put on show while being refrigerated by refrigerated air flowing through the interior. In addition to the above, a refrigerated showcase in which an air curtain is formed at a portion opened to the front side of a display chamber, as disclosed in a patent document 2 below, is also well known.

MEANS FOR SOLVING THE PROBLEMS

20

[0008] To solve the above problems, the present invention provides a refrigerated showcase with which foodstuffs are displayed, the refrigerated showcase comprising a display chamber in which the foodstuffs are displayed, a cover which covers at least the front side of the display chamber, a mounting lateral surface which is formed in the display chamber and constitutes a surface on the side where the foodstuffs are placed, and a vent which is positioned directly above the mounting lateral surface and from which refrigerated air is vented, wherein the cover is configured such that the foodstuffs displayed in the display chamber can be viewed from the outside, wherein the vent is positioned behind the front end of the mounting lateral surface in plan view, and wherein the direction in which the air is vented from the vent is oriented forward in plan view.

[0003] In regards to the refrigerated showcase as disclosed in the patent document 1, there is a possibility that the direct contact of air flowing through the display chamber with the foodstuffs would occur, thereby leading to deterioration of the quality of the foodstuffs due to dehydration of the foodstuffs, for instance.

25

[0004] The refrigerated showcase as disclosed in the patent document 2 is of a structure which makes it possible to form the air curtain in such a way that a ceiling part covering the upper side of the display chamber is extended ahead of the front end of a mounting lateral surface which constitutes a surface on the side where the foodstuffs in the display chamber are placed, thereby forming, in the ceiling part, a flow passage which permits refrigerated air to flow forward, and forming, at the front end side of the ceiling part, an air vent for the air flowing through the flow passage, wherein the direction in which the air is vented from the vent is oriented directly downward. This structure for forming the air curtain is complicated as described the above. Besides, refrigerated air is easily discharged from the front side of the display chamber to the outside, thereby resulting in causing the problem that energy efficiency is degraded.

30

[0009] The vent may also be configured such that the air is vented slantly downward to the front toward the front end of the mounting lateral surface.

35

[0005] Similar refrigerated showcases are already disclosed in JP S53 165260 U and EP 2 491 828 A1.

[0010] A space positioned on the front side of the mounting lateral surface in regards to the display chamber may also be formed with a suction port through which the air is sucked.

40

PRIOR ART DOCUMENTS

[0011] The cover may also be formed ranging from the front end side of a ceiling part covering at least a part of the upper side of the display chamber to the front surface side of the suction port, wherein the ceiling part is formed with a ceiling-side flow passage which constitutes a flow passage of refrigerated air and communicates with the vent.

45

PATENT DOCUMENTS

[0012] The vent may also be of a laterally long shape.
[0013] According to the invention, the refrigerated showcase has an inside openable/closable opening constituting an openable/closable opening to open and close the back surface side of the display chamber, and an outside openable/closable opening constituting an openable/closable opening to open and close a back surface-side portion of an outer wall of the refrigerated showcase,

50

[0006]

Patent document 1: Japanese Unexamined Utility Model Application Publication No. sho56-3379
 Patent document 2: Japanese Unexamined Patent

wherein the inside (front-side) openable/closable opening and the outside (rear-side) openable/closable opening are respectively positioned such as to be at least partly overlapped together in back view, and wherein a back surface-side flow passage constituting a flow passage which permits the refrigerated air to flow there-
though is formed between the inside (front-side) openable/closable opening and the outside (rear-side) openable/closable opening.

[0014] The openable/closable opening may also be an opening constituted of a plate-shaped sliding door which is capable of laterally sliding for opening and closing.

[0015] An inside sliding door serving as the sliding door constituting the inside openable/closable opening may also be formed with an air introducing part through which the air flowing through the back surface-side flow passage is introduced into the display chamber.

[0016] This refrigerated showcase may also be provided with another display chamber or a stock chamber which is formed, as a separate space, directly below the display chamber and in which the foodstuffs are displayed or stocked.

[0017] This refrigerated showcase may also be equipped with a voltage generator in which one output terminal thereof is connected to an electrode disposed in the display chamber.

EFFECTS OF THE INVENTION

[0018] According to the present invention with the above configuration, the cover is provided to cover at least the front side of the display chamber, and the position and direction in which the air is vented are appropriately oriented such that the direct contact of the refrigerated air with the foodstuffs displayed in the display chamber hardly occurs. For that reason, it can be appreciated that the quality of the foodstuffs can be kept satisfactory, while satisfactory energy efficiency can be achieved, without the need for any complicated structure.

BRIEF DESCRIPTION OF THE DRAWINGS

[0019]

[FIG. 1] FIG. 1 is a side sectional view of a refrigerated showcase to which the present invention is applied.

[FIG. 2] FIG. 2 is a front view of the refrigerated showcase of the present invention.

[FIG. 3] FIG. 3 is a side view of the refrigerated showcase of the present invention.

[FIG. 4] FIG. 4 is a back view of the refrigerated showcase of the present invention.

[FIG. 5] FIG. 5 is a back view of an inside sliding door.

[FIG. 6] FIG. 6 is a sectional view taken on line A-A' of FIG. 1.

[FIG. 7] FIG. 7 is a circuit diagram of a voltage generator.

MODE FOR EMBODYIGN THE INVENTION

[0020] FIG. 1 is a side sectional view of a refrigerated showcase to which the present invention is applied, FIGS. 2 to 4 are respectively a front view, a side view and a back view of the refrigerated showcase of the present invention, FIG. 5 is a back view of an inside sliding door, FIG. 6 is a sectional view taken on line A-A' of FIG. 1, and FIG. 7 is a circuit diagram of a voltage generator. A refrigerated showcase 1 is a box-shaped face-to-face showcase having outer dimensions of approximately 1500mm wide in a lateral direction, 1150mm tall and 750mm long. The refrigerated showcase 1 has a body part 2 made of stainless steel. The interior of the body part 2 is formed with a display chamber 3, a stock chamber 4 and an equipment chamber 6. The display chamber 3, the stock chamber 4 and the equipment chamber 6 are disposed in this order from the top toward the bottom in a multilayered manner.

[0021] The body part 2 has a front surface wall 7 which covers the front side of each of the stock chamber 4 and the equipment chamber 6, a pair of lateral surface walls 8 which respectively cover both the right and left sides of each of the stock chamber 4 and the equipment chamber 6, a back surface wall 9 which covers the back surface side of each of the display chamber 3 and the stock chamber 4, and a ceiling part 11 which covers a display chamber portion near the rear of an upper part of the display chamber 3.

[0022] Each of the right and left sides of the display chamber 3 is covered with a side plate 12. A display chamber portion ranging from the front surface side of the display chamber 3 to a portion near the front on the upper part side thereof is covered with a cover 13.

[0023] The cover 13 covers the display chamber 3 over the entire range thereof in a lateral direction. The cover 13 is of a circular arc shape in side cross-section view with the rear end thereof positioned in an upper end position and with the front end thereof positioned in a lower end position. It is to be noted that the cover 13 is not limited in shape to such curved shape but may be of a bent shape so as to widen a space slantly upward to the front of the display chamber 3.

[0024] The cover 13 is composed of a transparent material (specifically, transparent glass or transparent plastic, for instance) such that the foodstuffs displayed in the display chamber 3 can be viewed from the outside of the display chamber 3. A cover portion on the front-end side in the lower end position of the cover 13 is joined to the upper end of the front surface wall 7 which covers the front surface side of the stock chamber 4. A cover portion on the rear end side in the upper end position of the cover 13 is joined to the front end of the ceiling part 11. The joining range in this case is the entire region of both the cover 13 and the display chamber 3 in the lateral direction. In this way, the display chamber 3 can be a refrigerated space isolated from the outside.

[0025] The display chamber 3 and the stock chamber 4

disposed directly below the display chamber are partitioned by a display floor 14 constituting a floor part of the display chamber 3. The upper surface of the display floor 14 constitutes the floor surface of the display chamber 3 and can also be a mounting lateral surface 14a constituting a surface on the side where the foodstuffs are placed and displayed. A ventilation space 18 serving as a space through which air is passed while being refrigerated is formed between the stock chamber 4 and the equipment chamber 6. The stock chamber 4 and the ventilation space 18 are partitioned by a stock floor 16 constituting a floor part of the stock chamber 4. The upper surface of the stock floor 16 constitutes the floor surface of the stock chamber 4 and can also be a mounting lateral surface 16a constituting a surface on the side where the foodstuffs are stocked. The ventilation space 18 and the equipment chamber 6 are partitioned by a floor part 17 of the ventilation space 18, for instance.

[0026] Each of the display chamber 3 and the stock chamber 4 has, at the rear end side thereof, a pair of laterally long rectangular plate-shaped inside sliding doors (sliding door, inside openable/closable opening) 19 which are respectively fitted so as to be capable of laterally sliding for opening and closing, as an openable/closable opening constitution which is to communicate the inside of each of the display chamber and the stock chamber with the outside thereof in an openable/closable manner. The back surface wall 9 constituting a back surface-side portion of an outside wall (an outside wall of the refrigerated showcase) of the body part 2 also has a pair of laterally long rectangular plate-shaped outside sliding doors (sliding door, openable/closable opening) 21 which are respectively fitted so as to be capable of laterally sliding for opening and closing, as an openable/closable opening constitution which is to communicate the inside of the body part 2 with the outside thereof in an openable/closable manner.

[0027] Like the inside sliding doors 19, the outside sliding doors 21 are also provided individually for each of the display chamber 3 and the stock chamber 4. Specifically, the upper inside and outside sliding doors 19 and 21 provided to constitute the openable/closable opening for taking in and out the foodstuffs stored in the display chamber 3 are positioned such that most part of these sliding doors is overlapped in back view. Meanwhile, the lower inside and outside sliding doors 19 and 21 provided to constitute the openable/closable opening for taking in and out the foodstuffs stocked in the stock chamber 4 are also positioned such that most part of these sliding doors is overlapped in back view. Namely, the inside and outside sliding doors 19 and 21 constitute a double sliding door structure.

[0028] A space between the inside sliding doors 19 and the outside sliding doors 21 constitutes a back surface-side flow passage 22 serving as a flow passage of refrigerated air. In other words, the back surface-side flow passage 22 is formed between the back surface wall 9 and both the display chamber 3 and the stock

chamber 4. The back-surface side flow passage 22 and both the display chamber 3 and the stock chamber 4 communicate with each other in a manner of being openable and closable by the inside sliding doors 19. The back surface-side flow passage 22 and the outside communicate with each other in a manner of being openable and closable by the outside sliding doors 21.

[0029] The lower end of the back surface-side flow passage 22 communicates with the rear end of the ventilation space 18. An upper part of each inside sliding door 19 has air introducing holes (an air introducing part) 20 which are bored therein in the form of slits to permit air flowing through the back surface-side flow passage 22 to be introduced into the display chamber 3 or into the stock chamber 4. The process of introducing refrigerated air into the display chamber 3 or into the stock chamber 4 in this way results in also allowing the interior of each of the display chamber and the stock chamber to be refrigerated.

[0030] The upper end of the back surface-side flow passage 22 communicates with the rear end of a ceiling-side flow passage 26a (which will be described later) constituting an air flow passage formed on the ceiling part 11-side.

[0031] Specifically, the ceiling part 11 formed ranging over the laterally entire region in a rear half part of the display chamber 3 in plan view is formed with a cavity part 11a in which both the front and rear sides thereof are respectively fully opened. The cavity part 11a occupies most part of the ceiling part 11, wherein the rear end of the cavity part communicates with the upper end of the back surface-side flow passage 22.

[0032] A vent duct 26 in which the ceiling-side flow passage 26a is formed therein is inserted, in a removably fitted state, into the cavity part 11a from the opened front end of the cavity part 11a. The vent duct 26 occupies most part of or the entirety of the cavity part 11a, wherein the front end of the vent duct faces the display chamber 3-side, while the rear end thereof faces the back surface-side flow passage 22. In regards to the vent duct 26, the front end thereof facing the interior of the display chamber 3 is integrally extended slantly downward to the front to form a vent 27, while the rear end thereof is opened downward so as to communicate with the back surface-side flow passage 22.

[0033] The vent 27 is of a laterally long rectangular shape enough to permit the front-end side of the vent duct 26 to be opened fully. The vent 27 is positioned behind the front end of the mounting lateral surface 14a (specifically, in a position near the rear of the display chamber 3) in plan view in regards to the ceiling part 11-side within the display chamber 3. The direction in which the air is vented from the vent 27 is oriented slantly downward to the front toward a suction port 23 (which will be described later) in accordance with the extension direction of the vent duct.

[0034] A fixing means for the vent duct 26 will be now described in brief. A spacer 30 which is of a channel shape or rectangular shape in front view and in which

both the front and rear sides thereof are respectively opened is inserted, in a fitted state, into the ceiling-side flow passage 26a to meet the vertically dimensional stability of the ceiling-side flow passage. The right and left sides of the upper end or the lower end of the spacer 30 are respectively formed with longitudinally long flange parts 30a which are integral with the spacer and are projecting in the direction away from each other. The vent duct 26 is fixed to the ceiling part 11 together with the spacer 30 in such a way as to detachably mount, with bolts and the like, the right and left flange parts 30a of the spacer 30 to a ceiling body 11b constituting a ceiling portion other than the cavity part 11a of the ceiling part 11. Incidentally, the spacer 30 is provided in three positions in total, that is, a rightward position, a leftward position and a center position of the ceiling-side flow passage 26a.

[0035] Of course, the front end of the cavity part 11a may also be the vent, provided that the cavity 11a itself constitutes the ceiling-side flow passage, whereas it is to be noted that when a separate vent duct 26 is formed with both the ceiling-side flow passage 26a and the duct 27, appropriate change of various settings for both the ceiling-side flow passage 26a and the vent duct 27 is made possible by replacement of the separate vent duct, thereby leading to enhancement of versatility.

[0036] A front surface-side flow passage 24 constituting the air flow passage is formed between the stock chamber 4 and the front surface wall 7. The front surface-side flow passage 23 communicates with the display chamber 3 through the suction port 23. The suction port 23 is positioned at a portion which is in the vicinity of the front surface side of the mounting lateral surface 14a in regards to the display chamber 3, wherein the suction port is adjacent to the back surface of the lower end of the cover 13. The air vented into the display chamber 3 with a configuration (which will be described later) is sucked by the suction port 23, followed by being introduced into the front surface-side flow passage 24. The lower end of the front surface-side flow passage 24 communicates with the front end of the ventilation space 18.

[0037] The front surface-side flow passage 23 and the stock chamber 4 are partitioned by a partition wall 40 composed of a material such as metal with which heat conduction easily takes place. The refrigerated air flowing through the front surface-side flow passage 23 is supplied to the stock chamber 4 through the partition wall 40. Incidentally, the stock chamber 4 is also refrigerated by the air introduced into the stock chamber through the introducing holes 20 as described the above.

[0038] In the interior of the ventilation space 18, a fan 28 which blows the air toward the rear and a refrigerator 29 which refrigerates the air blown by the fan 28 are disposed in this order from the front toward the rear.

[0039] The air subjected to flowing by the fan 28 is firstly refrigerated by the refrigerator 29, and thereafter, flows into the back surface-side flow passage 22, followed by ascending therein. In regards to the air flowing

upward through the back surface-side flow passage 22, one part thereof is introduced into both the display chamber 3 and the stock chamber 4 through the introducing holes 20, while the other thereof is introduced into the ceiling-side flow passage 26a. The air introduced into the ceiling-side flow passage 26a flows forward, followed by being vented from the vent 27 into the display chamber 3.

[0040] Thanks to the above setting of the vent position and of the direction in which the air is vented, the air flowing slantly downward to the front in the display chamber 3 is sucked into the front surface-side flow passage 24 upon reaching the suction port 23 in a state where the direct contact of the air with the foodstuffs is suppressed or prevented. The air inside the front surface-side flow passage 24 flows downward while refrigerating the partition wall 40, followed by being introduced into the ventilation space 18. The air introduced into the ventilation space 18 is supplied again toward the rear by the fan 28, and thereafter, this cycle is repeated.

[0041] Namely, a circulation passage for circulation of the air in the order of the ventilation space 18 → the back surface-side flow passage 22 → the ceiling-side flow passage 26a → the display chamber 3 → the front surface-side flow passage 24 → the ventilation space 18 → ... is formed inside the refrigerated showcase 1. The circulating air is refrigerated by the refrigerator 29 as described the above. Thus, the process of refrigeration and circulation of the air in this way results in allowing both the display chamber 3 and the stock chamber 4 to be appropriately refrigerated.

[0042] Incidentally, the refrigerator 29 is composed of a vaporizer by which a refrigerant is subjected to vaporization. The refrigerator 29 constitutes a refrigerating equipment together with an equipment body 31 installed in the equipment chamber 6. The equipment body 31 has a compressor by which a low-temperature and low-pressure refrigerant resulting from vaporization by the refrigerator 29 is subjected to compression into a high-temperature and high-pressure state, a condenser by which the refrigerant from the compressor is refrigerated to promote liquification (condensation), and an expansion valve by which the refrigerant from the condenser is subjected to expansion and decompression. The refrigerant from the expansion valve is again subjected to vaporization by the refrigerator, and consequently, the air is refrigerated by the resultant heat of vaporization. Thereafter, this refrigerating cycle is repeated.

[0043] Moreover, the equipment chamber 6 is provided with a fan 32 by which the air warmed by the heat generated from the condenser and the like is discharged to the outside and refrigerated, a drain tank 33 and an electric equipment 34 (which will be described later) which performs control of application voltage, for instance, for both the display chamber 3 and the stock chamber 4. This electric equipment 34 includes a voltage generator 36 for the control of application voltage as shown in FIG. 7. Liquid such as water resulting from dew condensation in the ventilation space 18 during

refrigeration is discharged to the equipment chamber 6 through a waste liquid discharge hole 2a. The discharged liquid is stored in the drain tank 33.

[0044] Each of the mounting lateral surface 14a of the display chamber 3 and the mounting lateral surface 16a of the stock chamber 4 has a flat plate-shaped, meshed or latticed electrode 37 which is arranged thereon to generate an electric field inside each of the display chamber and the stock chamber. The electrode 37 is connected to the voltage generator 36 shown in FIG. 6. The foodstuffs are supposed to be directly placed on the electrode 37. The voltage generator 36 is a well-known voltage generator as disclosed in Japanese Patent Publication No. 2696310, for instance, wherein the voltage generator according to the above patented invention can be used as it is.

[0045] The voltage generator 36 is equipped with a leakage transformer 41 having a primary circuit connected to a power supply (AC100V) and a booster transformer 42 having a primary circuit connected to a secondary circuit of the leakage transformer 41. Both terminals 43a and 43b of the secondary circuit of the booster transformer 42 are integrated, together with the booster transformer 42, by a mold 44 composed of an insulating material such as epoxy resin. One terminal 43b of the secondary circuit of the booster transformer 42 is sealed inside the mold 44, while the other terminal 43a thereof is connected to an external circuit 47 via a resistor 46. The external circuit 7 is connected to the electrode 37 on the mounting lateral surface 14a and that on the mounting lateral surface 16a as described the above.

[0046] The above configuration results in allowing the foodstuffs placed on the electrodes 37 to be held in an electric field generating atmosphere, thereby making it possible to refrigerate and preserve the foodstuffs in a satisfactory condition without accompanying inconveniences such as generation of drip and food deterioration. Incidentally, it may be possible also that one or both of the inside and outside sliding doors 19 and 21 are provided with a detection means such as a sensor for detecting the open or closed state of the sliding doors, whereby application of voltage to each electrode 37 is automatically stopped in the middle of being detected that the inside and outside sliding doors 19 and 21 are in the open state.

[0047] In regards to the refrigerated showcase 1 having the above configuration, the air vented from the vent 27 into the display chamber 3 is supposed to flow slantly downward to the front toward the suction port 23 positioned on the front surface side of the display chamber 3, so that the direct contact of the vented air with the foodstuffs displayed in a display space 3a serving as a space ranging from a middle part of the display chamber 3 to the rear end thereof is suppressed or prevented. In particular, the air reaching the front-end side in the lower end position of the display chamber 3 is sucked into the suction port 23, so that turbulence of air flow hardly occurs. It is to be noted that the direction in which the air is vented from

the vent 27 may also be oriented frontward.

[0048] Further, as previously described, the air flows inside the refrigerated showcase 1 in a manner of circulation in a refrigerated state, in which case, however, because of the fact that the stock chamber 4 is not positioned on the circulation passage of the air flow, the contact of the air flow with the foodstuffs stocked in the stock chamber 4 hardly occurs, thereby resulting in preventing dehydration of the stocked foodstuffs. Furthermore, the display chamber 3 positioned on the circulation passage of the air flow is designed such that the inventive ideas are applied to the direction in which the air is vented and to the vent position, the contact of the air flow with the foodstuffs displayed in the display chamber 3 is also prevented, thereby making it possible to keep the quality of the displayed foodstuffs.

[0049] It is to be noted that the display floor 14 by which the display chamber 3 and the stock chamber 4 are partitioned may be of a structure which is capable of ventilation in a vertical direction. Alternatively, it may be possible also that the lower end of the cover 13 is extended up to the ventilation space 18-side, whereby the partition wall 40 is omitted so that the foodstuffs displayed in the stock chamber 4 can be viewed from the outside. In this case, the stock chamber 4 can be made to function as another display chamber. In which case, the display chambers 3 and 4 are in a two-stage formation in the vertical direction, or alternatively, may be formed in three or more stages.

EXPLANATION OF REFERENCE NUMERALS

[0050]

- 1: Refrigerated showcase
- 3: Display chamber
- 4: Stock chamber (Display chamber)
- 11: Ceiling part
- 13: Cover
- 14a: Mounting lateral surface
- 19: Inside openable/closable opening (sliding door, inside sliding door)
- 20: Introducing hole (Introducing part)
- 21: Outside openable/closable opening (sliding door, outside sliding door)
- 22: Back surface-side flow passage
- 23: Suction port
- 26a: Ceiling-side flow passage
- 27: Vent
- 36: Voltage generator
- 37: Electrode

Claims

1. A refrigerated showcase (1) with which foodstuffs are displayed, the refrigerated showcase comprising:

a display chamber (3) in which the foodstuffs are displayed;

a cover (13) which covers at least the front side of said display chamber;

a mounting lateral surface (14a) which is formed in said display chamber and constitutes a surface on the side where the foodstuffs are placed; and

a vent (27) which is positioned directly above said mounting lateral surface and from which refrigerated air is vented;

wherein said cover is configured such that the foodstuffs displayed in said display chamber can be viewed from the outside,

wherein said vent is positioned behind the front end of said mounting lateral surface in plan view, and

wherein the direction in which the air is vented from said vent is oriented forward in plan view,

characterized in that

the refrigerated showcase has an inside openable/closable opening (19) constituting an opening to open and close a back surface side of said display chamber, an outside openable/closable opening (21) constituting an opening to open and close a back surface side portion of an outer wall of the refrigerated showcase, wherein said inside openable/closable opening and said outside openable/closable opening are respectively positioned such as to be at least partly overlapped together in a back view, and wherein a back-side flow passage (22) serving as a flow passage which permits the refrigerated air to flow therethrough is formed between said inside openable/closable opening and said outside openable/closable opening.

2. The refrigerated showcase according to claim 1, wherein said vent is configured such that the air is vented slantly downward to the front toward the front end of said mounting lateral surface.
3. The refrigerated showcase according to claim 2, wherein a space positioned on the front side of said mounting lateral surface in regards to said display chamber is formed with a suction port (23) through which the air is sucked.
4. The refrigerated showcase according to claim 3, wherein said cover is formed ranging from the front end side of a ceiling part (11) which covers at least a part of the upper side of said display chamber to the front surface side of said suction port, and wherein said ceiling part is formed with a ceiling-side flow passage (26a) which constitutes a flow passage of refrigerated air and communicates with said vent.
5. A refrigerated showcase according to any one of

claims 1 to 4, wherein said vent is formed into an elongated shape in a left-right direction.

6. The refrigerated showcase according to claim 1, wherein said inside or outside openable/closable opening is constituted of a plate-shaped sliding door capable of laterally sliding for opening and closing.
7. The refrigerated showcase according to claim 6, wherein the inside sliding door serving as said sliding door constituting said inside openable/closable opening is formed with an air introducing part through which the air flowing through said back surface-side flow passage is introduced into said display chamber.
8. The refrigerated showcase according to any one of claims 1 to 7, wherein the refrigerated showcase is provided with another display chamber or a stock chamber which is formed as a separate space directly below said display chamber and in which the foodstuffs are displayed or stocked.
9. The refrigerated showcase according to any one of claims 1 to 8, wherein the refrigerated showcase is equipped with a voltage generator (36) in which one output terminal thereof is connected to an electrode disposed in said display chamber.

Patentansprüche

1. Kühlvitrine (1), in der Lebensmittel dargeboten werden, wobei die Kühlvitrine umfasst:

einen Darbietungsraum (3), in dem die Lebensmittel dargeboten werden;

eine Abdeckung (13), die zumindest die Vorderseite des Darbietungsraums abdeckt;

eine montageseitige Fläche (14a), die in dem Darbietungsraum ausgebildet ist und eine Fläche auf derjenigen Seite bildet, auf der die Lebensmittel platziert werden; und

eine Lüftung (27), die direkt über der montageseitigen Fläche angeordnet ist und aus der gekühlte Luft abgeführt wird;

wobei die Abdeckung so gestaltet ist, dass die in dem Darbietungsraum dargebotenen Lebensmittel von außen betrachtet werden können, wobei die Lüftung in der Draufsicht hinter dem vorderen Ende der montageseitigen Fläche angeordnet ist, und

wobei die Richtung, in der die Luft aus der Lüftung abgeführt wird, in der Draufsicht nach vorne gerichtet ist,

dadurch gekennzeichnet, dass

die Kühlvitrine eine zu öffnende/verschließende Innenöffnung (19) aufweist, die eine Öffnung

- zum Öffnen und Schließen der Rückflächenseite des Darbietungsraums bildet, sowie eine zu öffnende/verschließende Außenöffnung (21), die eine Öffnung zum Öffnen und Schließen eines rückflächenseitigen Abschnitts einer Außenwand der Kühlvitrine bildet, wobei die zu öffnende/verschließende Innenöffnung und die zu öffnende/verschließende Außenöffnung jeweils so positioniert sind, dass sie sich in der Rückansicht zumindest teilweise überlappen, und wobei zwischen der zu öffnenden/verschließenden Innenöffnung und der zu öffnenden/verschließenden Außenöffnung ein rückseitiger Strömungsdurchgang (22) ausgebildet ist, der als Strömungsdurchgang zum Durchströmen von gekühlter Luft dient.
2. Kühlvitrine nach Anspruch 1, wobei die Lüftung so gestaltet ist, dass die Luft schräg nach unten zur Vorderseite in Richtung des vorderen Endes der montageseitigen Fläche geführt wird.
 3. Kühlvitrine nach Anspruch 2, wobei ein auf der Vorderseite der montageseitigen Fläche in Bezug auf den Darbietungsraum angeordneter Raum mit einer Ansaugöffnung (23) versehen ist, durch die die Luft angesaugt wird.
 4. Kühlvitrine nach Anspruch 3, wobei die Abdeckung so ausgebildet ist, dass sie von der Vorderendseite eines Deckenteils (11), das zumindest einen Teil der Oberseite des Darbietungsraums abdeckt, bis zur Vorderflächenseite der Ansaugöffnung reicht, und wobei das Deckenteil mit einem deckenseitigen Strömungsdurchgang (26a) ausgebildet ist, der einen Strömungsdurchgang für gekühlte Luft bildet und mit der Lüftung in Verbindung steht.
 5. Kühlvitrine nach einem der Ansprüche 1 bis 4, wobei die Lüftung in länglicher Form in Breitenrichtung ausgebildet ist.
 6. Kühlvitrine nach Anspruch 1, wobei die zu öffnende/verschließende Innen- oder Außenöffnung durch eine plattenförmige Schiebetür gebildet wird, die zum Öffnen und Schließen seitlich verschiebbar ist.
 7. Kühlvitrine nach Anspruch 6, wobei die innere Schiebetür, die als diejenige Schiebetür dient, welche die zu öffnende/schließende Innenöffnung bildet, mit einem Lufteinleitteil ausgebildet ist, durch das durch den rückflächenseitigen Strömungsdurchgang strömende Luft in den Darbietungsraum eingeleitet wird.
 8. Kühlvitrine nach einem der Ansprüche 1 bis 7, wobei die Kühlvitrine mit einem weiteren Darbietungsraum oder einem Vorratsraum versehen ist, der als sepa-

rater Raum direkt unterhalb des Darbietungsraums ausgebildet ist und in dem die Lebensmittel dargeboten oder gelagert werden.

9. Kühlvitrine nach einem der Ansprüche 1 bis 8, wobei die Kühlvitrine mit einem Spannungsgenerator (36) ausgestattet ist, von dem ein Ausgangsanschluss mit einer in dem Darbietungsraum angeordneten Elektrode verbunden ist.

Revendications

1. Vitrine réfrigérée (1), avec laquelle des aliments sont présentés, la vitrine réfrigérée comprenant :

une chambre d'affichage (3), dans laquelle sont présentés les aliments ;

un couvercle (13), qui recouvre au moins la face avant de ladite chambre d'affichage ;

une surface latérale de montage (14a), qui est formée dans ladite chambre de présentation et constitue une surface sur le côté où sont placés les aliments ; et

un événement (27), qui est positionné directement au-dessus de ladite surface latérale de montage et à partir duquel l'air réfrigéré est évacué ;

dans laquelle ledit couvercle est configuré de telle sorte que les aliments présentés dans ladite chambre de présentation puissent être vus de l'extérieur,

dans laquelle ledit événement est positionné derrière l'extrémité avant de ladite surface latérale de montage dans une vue en plan, et

dans laquelle la direction dans laquelle l'air est évacué dudit événement est orientée vers l'avant dans la vue en plan,

caractérisée en ce que

la vitrine réfrigérée présente une ouverture intérieure pouvant être ouverte/fermée (19) constituant une ouverture pour ouvrir et fermer le côté de surface arrière de ladite chambre de présentation, une ouverture extérieure pouvant être ouverte/fermée (21) constituant une ouverture pour ouvrir et fermer une partie latérale de surface arrière d'une paroi extérieure de la vitrine réfrigérée, dans laquelle ladite ouverture intérieure pouvant être ouverte/fermée et ladite

ouverture extérieure pouvant être ouverte/fermée sont respectivement positionnées de manière à se chevaucher au moins en partie ensemble dans une vue arrière, et dans laquelle un passage d'écoulement côté arrière (22) servant de passage d'écoulement qui permet à l'air réfrigéré de s'écouler à travers celui-ci est formé

entre ladite ouverture intérieure pouvant être ouverte/fermée et ladite ouverture extérieure pouvant être ouverte/fermée.

2. Vitrine réfrigérée selon la revendication 1, dans laquelle ledit événement est configuré de sorte que l'air est évacué à l'oblique vers le bas à l'avant vers l'extrémité avant de ladite surface latérale de montage. 5
3. Vitrine réfrigérée selon la revendication 2, dans laquelle un espace positionné sur le côté avant de ladite surface latérale de montage par rapport à ladite chambre de présentation est formé avec un orifice d'aspiration (23), à travers lequel l'air est aspiré. 10
4. Vitrine réfrigérée selon la revendication 3, dans laquelle ledit couvercle est formé en s'étendant depuis le côté d'extrémité avant d'une partie de plafond (11), qui recouvre au moins une partie du côté supérieur de ladite chambre de présentation jusqu'au côté de surface avant dudit orifice d'aspiration, et dans laquelle ladite partie de plafond est formée avec un passage d'écoulement côté plafond (26a), qui constitue un passage d'écoulement d'air réfrigéré et communique avec ledit événement. 15
20
5. Vitrine réfrigérée selon l'une quelconque des revendications 1 à 4, dans laquelle ledit événement est de forme rectangulaire allongée dans une direction gauche-droite. 25
6. Vitrine réfrigérée selon la revendication 1, dans laquelle ladite ouverture intérieure ou extérieure pouvant être ouverte/fermée est constituée d'une porte coulissante en forme de plaque capable de coulisser latéralement pour l'ouverture et la fermeture. 30
7. Vitrine réfrigérée selon la revendication 6, dans laquelle la porte coulissante intérieure servant de porte coulissante constituant ladite ouverture intérieure pouvant être ouverte/fermée est formée avec une partie d'introduction d'air, à travers laquelle l'air s'écoulant à travers ledit passage d'écoulement côté surface arrière est introduit dans ladite chambre de présentation. 35
40
8. Vitrine réfrigérée selon l'une quelconque des revendications 1 à 7, dans laquelle la vitrine réfrigérée est pourvue d'une autre chambre de présentation ou d'une chambre de stockage qui est formée comme un espace séparé directement en dessous de ladite chambre de présentation et dans laquelle les aliments sont présentés ou stockés. 45
50
9. Vitrine réfrigérée selon l'une quelconque des revendications 1 à 8, dans laquelle la vitrine réfrigérée est équipée d'un générateur de tension (36), dans lequel une borne de sortie de celui-ci est reliée à une électrode disposée dans ladite chambre de présentation. 55

FIG. 1

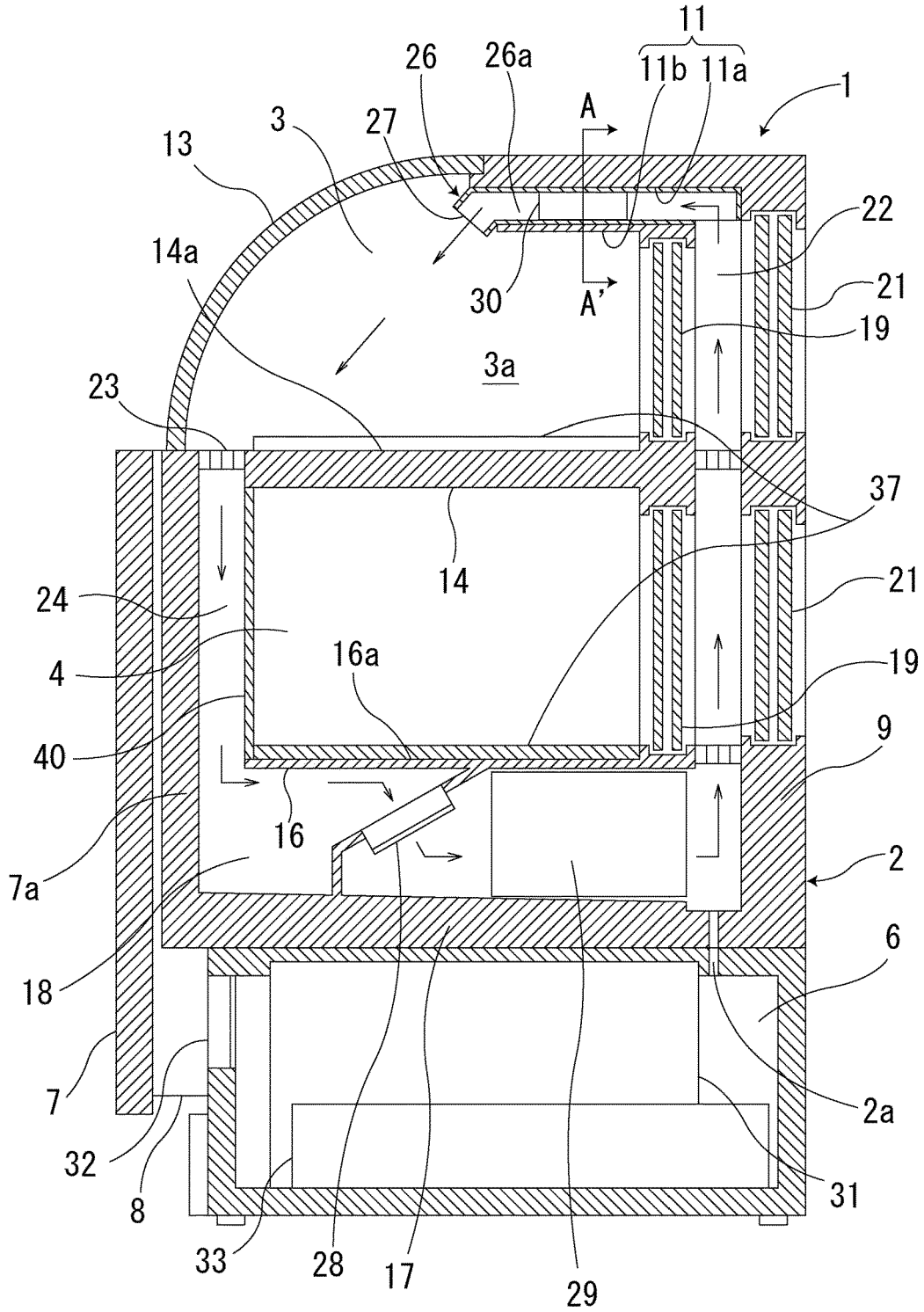
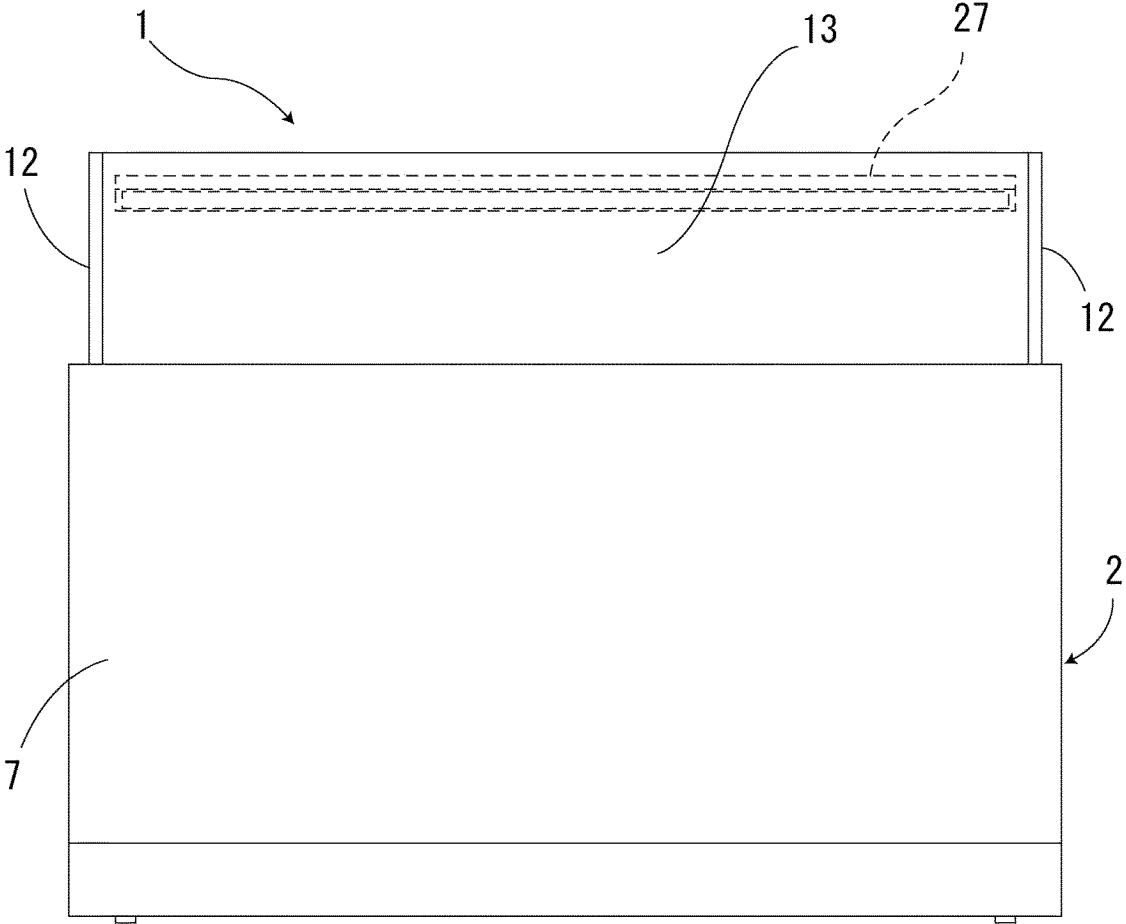

FIG. 2



F I G . 3

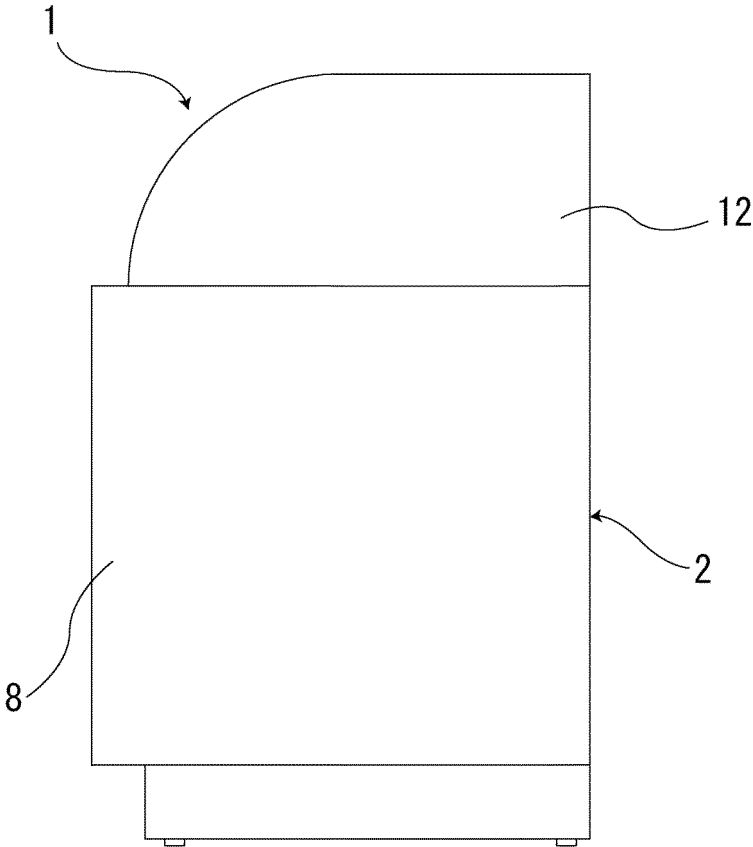

FIG. 4

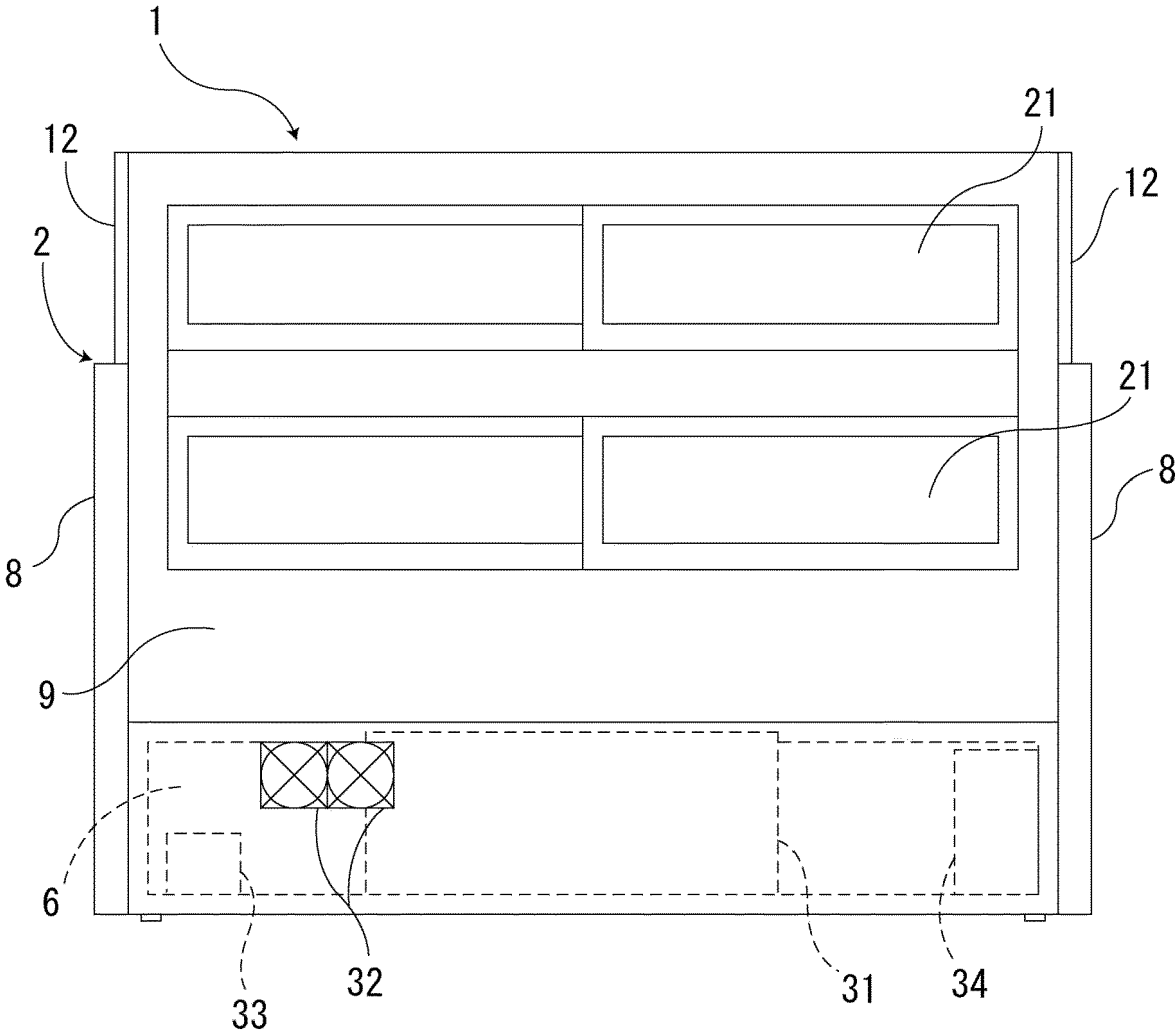

FIG. 5

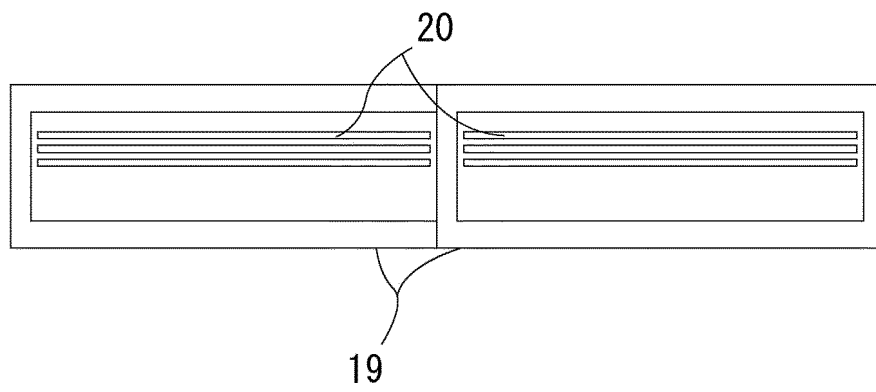

FIG. 6

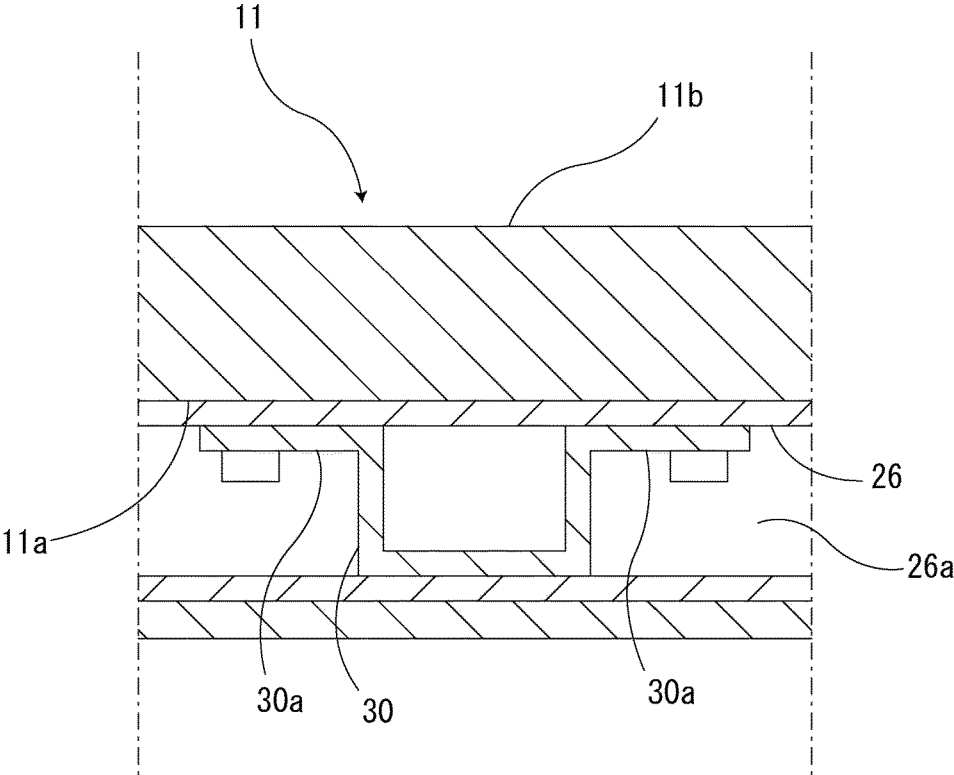
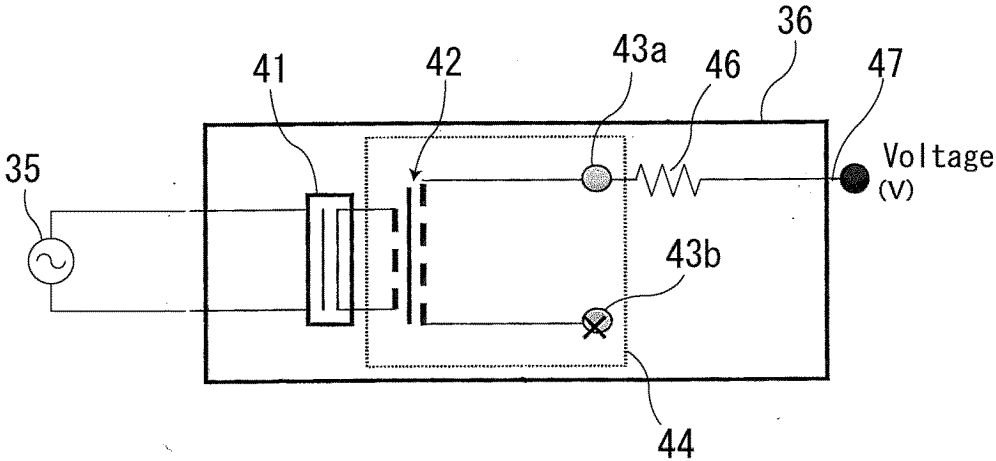

FIG. 7



REFERENCES CITED IN THE DESCRIPTION

This list of references cited by the applicant is for the reader's convenience only. It does not form part of the European patent document. Even though great care has been taken in compiling the references, errors or omissions cannot be excluded and the EPO disclaims all liability in this regard.

Patent documents cited in the description

- JP 53165260 U [0005]
- EP 2491828 A1 [0005]
- JP 56003379 U [0006]
- JP 2004340411 A [0006]
- JP 2696310 B [0044]