

(19) World Intellectual Property Organization  
International Bureau



(43) International Publication Date  
27 May 2010 (27.05.2010)

PCT

(10) International Publication Number  
**WO 2010/058289 A2**

- (51) **International Patent Classification:**  
*B24B 21/00* (2006.01)    *B24D 11/00* (2006.01)  
*B24D 99/00* (2010.01)
- (21) **International Application Number:**  
PCT/IB2009/007588
- (22) **International Filing Date:**  
20 November 2009 (20.11.2009)
- (25) **Filing Language:** Italian
- (26) **Publication Language:** English
- (30) **Priority Data:**  
MI2008A 002086 21 November 2008 (21.11.2008) IT  
MI2009A 001599  
18 September 2009 (18.09.2009) IT
- (71) **Applicant (for all designated States except US):** MAN-  
GUSTA S.R.L. [IT/IT]; Piazza Gramsci 58, I-20092  
Cinisello Balsamo MI (IT).
- (72) **Inventors; and**
- (75) **Inventors/Applicants (for US only):** CASSARA', Paolo  
[IT/IT]; Via Bellinzona 7, I-20052 Monza MB (IT).  
CASSARA', Carlo [IT/IT]; Strada al lago 5, I-20090  
Sagrate MI (IT). CASSARA', Gianpaolo, Vittorio  
[IT/IT]; Via Bellinzona 7, I-20052 Monza MB (IT).
- (74) **Agents:** FARAGGIANA, Vittorio et al.; Barzano' & Za-  
nardo Milano S.p.A., Via Borgonuovo, 10, 20121 Milano  
MI (IT).

- (81) **Designated States (unless otherwise indicated, for every kind of national protection available):** AE, AG, AL, AM, AO, AT, AU, AZ, BA, BB, BG, BH, BR, BW, BY, BZ, CA, CH, CL, CN, CO, CR, CU, CZ, DE, DK, DM, DO, DZ, EC, EE, EG, ES, FI, GB, GD, GE, GH, GM, GT, HN, HR, HU, ID, IL, IN, IS, JP, KE, KG, KM, KN, KP, KR, KZ, LA, LC, LK, LR, LS, LT, LU, LY, MA, MD, ME, MG, MK, MN, MW, MX, MY, MZ, NA, NG, NI, NO, NZ, OM, PE, PG, PH, PL, PT, RO, RS, RU, SC, SD, SE, SG, SK, SL, SM, ST, SV, SY, TJ, TM, TN, TR, TT, TZ, UA, UG, US, UZ, VC, VN, ZA, ZM, ZW.
- (84) **Designated States (unless otherwise indicated, for every kind of regional protection available):** ARIPO (BW, GH, GM, KE, LS, MW, MZ, NA, SD, SL, SZ, TZ, UG, ZM, ZW), Eurasian (AM, AZ, BY, KG, KZ, MD, RU, TJ, TM), European (AT, BE, BG, CH, CY, CZ, DE, DK, EE, ES, FI, FR, GB, GR, HR, HU, IE, IS, IT, LT, LU, LV, MC, MK, MT, NL, NO, PL, PT, RO, SE, SI, SK, SM, TR), OAPI (BF, BJ, CF, CG, CI, CM, GA, GN, GQ, GW, ML, MR, NE, SN, TD, TG).

**Declarations under Rule 4.17:**

— as to applicant's entitlement to apply for and be granted a patent (Rule 4.17(ii))

**Published:**

— without international search report and to be republished upon receipt of that report (Rule 48.2(g))

(54) **Title:** IMPROVED ABRASIVE BELT AND DEVICE FOR POLISHING SURFACES PROVIDED WITH SUCH BELT

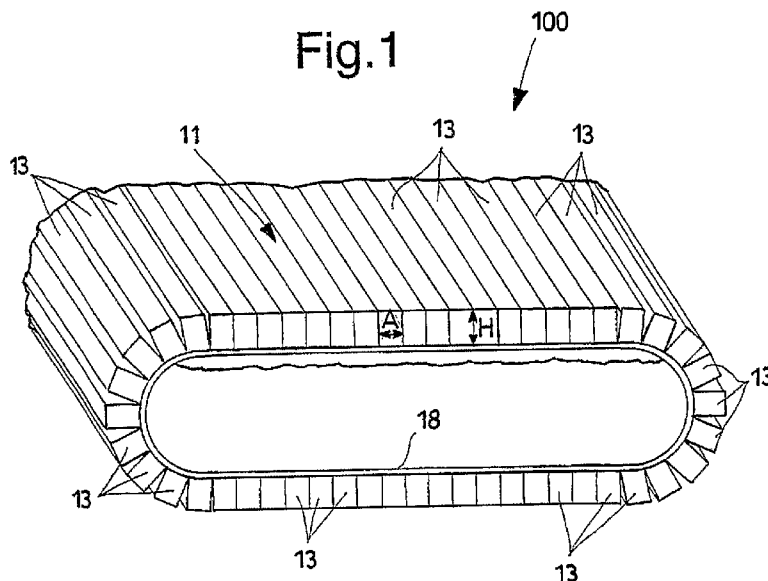

(57) **Abstract:** An abrasive belt (100) for surface polishing machines of the type having a flexible ring provided with a substantially inextensible internal layer (18) onto which an external abrasive layer (11) is fixed, wherein the external abrasive layer (11) is made up of a plurality of sectors (13) adjacent and at mutual contact, separated by transverse cuttings with respect to the longitudinal direction of the belt (100), the sectors (13) having a width (A) measured in the longitudinal direction of the belt (100) smaller than their height (H) measured in the transverse direction with respect to the surface of the belt (100) and being deformable under the polishing pressure.



WO 2010/058289 A2

"IMPROVED ABRASIVE BELT AND DEVICE FOR POLISHING SURFACES PROVIDED WITH SUCH BELT"

The present invention relates to an improved abrasive belt  
5 and to a device for polishing surfaces using such belt.

Devices are known for the surface polishing of some particular products, comprising an abrasive belt of the type having a flexible ring moved in sliding between return rollers, of which at least one motor-driven.

10 Known abrasive belts are made with a material provided with a substantially inextensible internal support layer, onto which a powdery abrasive material, that is, shaped as a thin strip as well, is applied by various known techniques, so as to not impair the belt flexibility.

15 Such flexibility affects the bending the belt may take without damage, and therefore the diameter of the return rollers between which it is stretched, for determining the rectilinear branches that constitute the main working surface. The roller diameter must be as small as possible to limit  
20 the polishing machine overall dimensions. Considering the sliding speed of the belt, and the winding frequency on the rollers, the internal stresses must be moderate to ensure stress endurance over time, therefore the belt thickness cannot generally exceed the range of a few millimeters.

25 US 925942 describes a polishing machine comprising a belt conveyor whereon a plurality of single non-deformable abrasive blocks is mounted, separate from each other along the longitudinal development of the conveyor belt. Each abrasive block is removably associated to the conveyor belt

by a respective support plate, which is fixed to the conveyor belt and whereon the abrasive block is secured by screws. The single abrasive blocks consist of a stiff support the surface whereof intended for contacting the product to be polished is shaped with a profile that in cross section  
5 closely follows that of the product to be polished and that is coated with an abrasive layer.

The splitting of the abrasive into a plurality of discrete blocks allows returning the conveyor belt on the winding  
10 rollers also if the blocks have a certain height, considered in a direction orthogonal to the lying plane of the belt.

However, the abrasive blocks, in the belt portion comprised between the return rollers, work as a stiff wheel suitable only for processing the products it is shaped on; in order to  
15 process products having a different profile in cross section it is therefore necessary to replace the abrasive sectors.

US 2001911 describes an abrasive item that comprises a flexible support whereon a plurality of single non-deformable abrasive blocks separate from each other is applied, wherein  
20 an intermediate layer is interposed between the support and the abrasive blocks, made of a resilient material. The single blocks are made of a stiff and thick abrasive material, whereas the intermediate layer is made, for example, of soft rubber. US 2001911 teaches, in particular, the use of  
25 such abrasive element as coating layer for abrasive items such as wheels and discs. According to the teachings of US 2001911, the intermediate layer of resilient material allows the single abrasive blocks, per se stiff and thick, to individually yield under the grinding pressure.

Nevertheless, the abrasive element described in US 2001911 does not allow continuously following the profile variations, in both cross and longitudinal direction, of any product to be processed.

5 The object of the present invention is to provide an improved abrasive belt and a device for polishing surfaces provided with such belt capable of solving the disadvantages of the prior art mentioned above in a very simple, inexpensive and particularly functional manner.

10 Another object is to provide an improved abrasive belt and a device for polishing surfaces provided with such belt provided with a high effectiveness and wear resistance and which should not force the user to frequently replace the belt itself.

Another object is to provide an improved abrasive belt and a  
15 device for polishing surfaces provided with such belt capable of adjusting and following variations of the profile of the products to be processed in both longitudinal and cross direction thereto.

These objects according to the present invention are achieved  
20 by providing an improved abrasive belt and a device for polishing surfaces provided with such belt as defined in the following claims.

The features and the advantages of the invention will appear more clearly from the following description of a practical  
25 embodiment of the invention, made by way of a non-limiting example illustrated in the annexed schematic drawings, wherein:

figure 1 shows a perspective view of an abrasive belt according to the present invention;

figure 2 shows an elevation view of a device for polishing surfaces provided with the abrasive belt of figure 1;

figure 3 shows an enlarged detail of an alternative embodiment of an abrasive belt according to the present invention;

figure 4 shows a cutaway elevation view of the device of figure 2 during the processing of a section bar; and

figure 5 shows a section view of the device of figure 4 along line V-V.

10 With reference to the figures, reference numeral 100 shows an improved abrasive belt according to the present invention and reference numeral 10 a device for polishing surfaces provided with such belt 100.

Such abrasive belt 100 for surface polishing machines, as shown in figure 1, is of the type having a flexible ring and provided with a substantially inextensible internal layer 18 onto which an external abrasive layer 11 is fixed, for example by adhesive.

In particular, according to the invention, such external abrasive layer 11 consists of a plurality of sectors 13 adjacent and at mutual contact, separated by transverse cuttings with respect to the longitudinal direction of belt 100. These sectors 13 have a width indicated with A, measured in the longitudinal direction of belt 100, and a height H, measured in the transverse direction with respect to the surface of belt 100.

The structure of the belt according to the invention allows using an abrasive whose height H is very high, even up to several centimeters.

This height does not impair the belt flexibility without the abrasive being subject to inadmissible stresses, keeping width A below a suitable maximum threshold identified by the Applicant as 15 mm, without excluding the possibility  
5 to reach 18-25 mm.

Based on elementary geometrical considerations, the winding on a return roller imposes, on each sector, a bending proportional to the ratio between the sector width on the roller circumference.

10 Keeping width A limited with respect to the bending radius, the belt is foreseeably subject to, a good belt flexibility is obtained, with adequately low stress of materials, although capable of relatively limited elastic elongation and also for a large thickness of the abrasive layer.

15 In a preferred embodiment, sectors 13 are deformable and yielding under the polishing pressure so as to conform to the profile of the product being processed following the variations of the same in both longitudinal and cross direction.

20 Sector deformable under the polishing pressure indicates a sector which, by its nature and structure, when it contacts the processing surface, under the polishing pressure, conforms to the latter following the profile thereof with continuity.

25 The way such sectors 13 get deformed, bending in a direction longitudinal to the belt and locally yielding by squeezing, following the pattern of the profile of surface 21 of a product, is schematically shown, in a marked manner by way of an example only, in figures 4 and 5.

The deformability property of sectors 13 is due to both the material they are made of and to the shape and size thereof. In particular, sectors 13 are made of a deformable material consisting of open pore non-woven fabric and wherein  
5 a charge of abrasive material in particles is dispersed. Preferably, the non-woven fabric is made of polymeric fibers linked by a resin, where, even more preferably, the polymeric fibers are Nylon<sup>TM</sup> fibers and the resin is a phenolic resin. On the other hand, the abrasive material is selected from  
10 the group comprising aluminum oxide and silicon carbide, although the use of other abrasive materials is not excluded.

A non-woven fabric of this kind is known by the name "SCOTCH-BRITE<sup>TM</sup>" by 3M (Minnesota Mining and Manufacturing  
15 Company).

Each sector 13 then consists of a sheet arranged crosswise to the longitudinal direction of the belt. As will appear more clearly hereinafter, the ratio between the thickness of each sheet, coinciding with width A of sector 13, and  
20 one of the two sides thereof, coinciding with height H of sector 13, has defined values.

According to a preferred embodiment, sectors 13 made of abrasive material have a substantially parallelepiped section and radially projecting from the internal layer 18 of belt  
25 100 to which they are constrained.

In fact, such parallelepiped sectors 13 are provided with first lower ends constrained to the internal layer 18 in mutual side contact and with second free ends opposite to the constrained ends.

According to the alternative embodiment shown in figure 3, the external abrasive layer 11 is removably fixable on the internal layer 18 through the pressure coupling of two fabric strips 30, 31 respectively arranged one underneath  
5 the external abrasive layer 11 and the other above the internal layer 18, capable of mutually adhering by simple approach.

Typical example of this fabric material is known on the market by the name of "VELCRO<sup>TM</sup>", where the combination of  
10 the two strips 30, 31 takes place thanks to the fact that the surface of one fabric is provided with hook projections that engage into the fibers of the other layer.

The adhesion stress of this material has proved to be sufficient for withstanding the essentially tangential  
15 detachment force that arises in the use of the belt, while allowing a detachment of the abrasive layer with a limited effort.

Such embodiment is advantageous since it allows both keeping the external abrasive layer 11 steadily fixed to the internal  
20 one 18 and easily releasing it, if required, for example for replacing a worn abrasive layer 11 with a new one or for replacing the abrasive belt 11 being used with another one having different features.

The VELCRO<sup>TM</sup> layer 31, adhering, for example glued, to the  
25 abrasive layer 11 may be applied to any single sector separately, but it is advantageously continuous, there being glued the various abrasive sectors thereon, forming a continuous band that facilitates the quick application of the abrasive layer on the bearing internal layer 18.

Likewise, also the other VELCRO™ layer 30 may be constrained, for example glued, continuously to an internal layer 18 of material with the required mechanical features for the return between the rollers.

5 Alternatively, the internal layer 18 itself may be directly made of a material that on one face thereof has the features suitable for constituting one of the components of the "VELCRO™" coupling, so layers 18 and 30 make a single layer. The sectors may be separated by cuttings even not perfectly  
10 transverse to the belt, but a deviation implies an increase of the sector deformation for belt bending.

According to another embodiment, not shown, the abrasive belt 100 may comprise abrasive elements shaped as sheets, of the type per se known as "cloth or abrasive paper" with  
15 cloth or paper or equivalent support, arranged at the transverse separation cuttings of sectors 13 described above, with the desired frequency. In this way, a combined action of the two types of abrasive that make up the elements mounted on the support belt is carried out on the body  
20 being processed with the desired alternation.

The thickness of the abrasive sectors is not critical, and in the process they appear with one of their faces in the feeding direction of the belt on the piece being processed. Therefore, sectors 13 may all consist of portions of abrasive cloth, side  
25 by side and adjacent as described above, applied orthogonal to the belt, with the face carrying the abrasive directed in the forward moving direction of the belt on the piece.

In these conditions, in the belt according to the invention, it has been found that the abrasive cloth carrying the

abrasive on only one of the two faces has a behavior that approaches that of sectors consisting of a support matrix wherein the abrasive is evenly dispersed.

Figure 2 shows a device 10 for polishing surfaces 21 provided with a belt 100 as described above.

In particular, according to the invention, there is schematically shown device 10, showing a belt polishing machine in se known. The belt is returned by at least two rollers 17, 17' for defining a flat intermediate section for polishing a surface 21.

In order to move the abrasive belt 100, it is provided for at least one roller 17', to be moved in rotation by a dedicated motor.

An abrasive belt 100, of the type described above, with reference to figure 1, is mounted on the polishing machine.

With reference to radius R of the return rollers 17, 17' it is provided for sectors 13 to have a width A, measured in the longitudinal direction of belt 100, equal to a fraction of the roller circumference, preferably smaller than radius R of return rollers 17, 17'.

Width A is preferably equal to a fraction of height H, for example comprised between  $1/2$  and  $1/10$ , preferably between  $1/4$  and  $1/8$ .

As indicated above, moreover, each sector 13 consists of a sheet that has a thickness equal to width A and a height equal to H, where width A is smaller than or equal to 15 mm and height H is smaller than or equal to 60 mm, although extending width A to 18-25 mm and height H to 180-250 mm is not excluded.

Device 10 comprises means for guiding the flat intermediate polishing plane that creates between return rollers 17, 17', for evenly pressing the belt against surface 21 to be polished and ensure the contact of a plurality of sectors 13 against  
5 the same surface 21 to be polished.

It is very easy to understand how the object of the present invention operates.

The belt structure according to the invention advantageously allows having, during the use of the belt, an abrasive  
10 layer 11 splittable into portions wherein sectors 13 are into different mutual positions.

As is seen in figure 2, in the portions comprised between return rollers 17 and 17', sectors 13 are arranged one adjacent the other, preferably with no air gaps, with a  
15 behavior totally similar to a belt wherein the abrasive layer consists of a continuous band. Moreover, thanks to the typical deformability of the single sectors, due to both the material they are made of and to the shape and dimensions thereof, under the polishing pressure they adapt  
20 and follow the variations of the profile of the product to be processed in both longitudinal and cross direction.

In the portions wherein the belt bends to wrap on returns 17 and 17', the external ends of sectors 13 are free to move away from one another. Each sector is free to take a radial  
25 position with respect to the return rollers, and is bent by the extent of the angle subtended by the support surface, negligible for adequately limited width of the sector.

Inadmissible tensions would generate in such curvilinear portions within a known stiff abrasive belt of the same

thickness, such as to make the use thereof impossible.

It has therefore been seen that an improved abrasive belt and a device for polishing surfaces provided with such belt according to the present invention achieve the objects  
5 illustrated above.

In fact, the improved abrasive belt according to the present invention allows having an abrasive layer provided with an adequate stiffness so as not to excessively deform under the working stress and at the same time with such height as  
10 to make it resistant to wear.

The high flexibility resulting from the structure according to the invention also allows mounting very wide belts on the polishing machine, for processing large surfaces, without inducing excessive stress for the motor driven sliding of  
15 the belt, with consequent need of oversizing the pulling motors and wasting energy.

The improved abrasive belt according to the present invention allows a great freedom of choice as far as the mechanical features and material removal effectiveness of the abrasive  
20 material are concerned.

The machine using such belt is suitable for perfectly processing any kind of surface and at the same time it does not force the user to frequently replace the belt itself anymore.

25 Several changes and variations can be made to the improved abrasive belt and the device for polishing surfaces provided with such belt of the present invention thus conceived, all falling within the same inventive concept; moreover, all details can be replaced with technically equivalent elements.

In the practice, the materials used as well as their sizes, can be whatever according to the technical requirements.

## CLAIMS

- 1) Abrasive belt (100) for surface polishing machines of the type having a flexible ring provided with a substantially inextensible internal layer (18) onto which an external abrasive layer (11) is fixed, made up of a plurality of sectors (13) adjacent and at mutual contact, separated by transverse cuttings with respect to the longitudinal direction of said belt (100), characterized in that each of said sectors (13) has a width (A) measured in the longitudinal direction of said belt (100) smaller than the height (H) measured in the transverse direction with respect to the surface of said belt (100) and is deformable under the polishing pressure.
- 2) Abrasive belt (100) according to claim 1 characterized in that each of said sectors is made up of a sheet arranged orthogonally to said longitudinal direction.
- 3) Abrasive belt (100) according to claim 1 or 2, characterized in that said sectors (13) are made of a deformable material consisting of an open pore non-woven fabric and wherein a charge of abrasive material is dispersed.
- 4) Abrasive belt (100) according to claim 3 characterized in that said non-woven fabric is made of polymeric fibers linked by a resin.
- 5) Abrasive belt according to claim 4 characterized in that said polymeric fibers are Nylon<sup>TM</sup> fibers and said resin is a phenolic resin and wherein said abrasive material is selected from the group comprising aluminum oxide and silicon carbide.

- 6) Abrasive belt (100) according to one or more of the previous claims, characterized in that said sectors have a width (A) equivalent to a fraction of their height (H), comprised between  $1/2$  and  $1/10$ , preferably between  $1/4$  and  $1/8$ .
- 7) Abrasive belt (100) according to claim 6 characterized in that said sectors have a width (A) smaller than or equal to 15 mm and a height (H) smaller than or equal to 60 mm.
- 8) Abrasive belt (100) according to claim 1 characterized in that said sectors (13) made of abrasive material have a substantially parallelepiped section projecting radially from the internal layer (18) of said belt (100), said sectors (13) being provided with first lower ends constrained to said internal layer (18) in mutual side contact and second free ends opposite to said constrained ends.
- 9) Abrasive belt (100) according to any one of the preceding claims characterized in that it comprises sectors of different thickness and type alternating longitudinally on the belt.
- 10) Abrasive belt (100) according to claim 1 characterized in that said sectors (13) are elements made up of a support matrix made of abrasive material or in which abrasive material is dispersed, variously alternating with a cloth or abrasive paper.
- 11) Abrasive belt (100) according to claim 1 characterized in that said sectors (13) are elements made up of cloth sheets or abrasive paper.
- 12) Abrasive belt (100) according to claim 1, characterized in that said external abrasive layer (11) is removably fixable on the internal layer (18) through the pressure coupling of

surface elements arranged respectively underneath said external abrasive layer (11) and above said internal layer (18) provided with pressure-wise connecting elements of the "VELCRO<sup>TM</sup>" type.

5 13) Device (10) for polishing surfaces (21) comprising an abrasive belt (100) of the type having a flexible ring provided with a substantially inextensible internal layer (18) onto which an external abrasive layer (11) is fixed and returned by at least two rollers (17, 17') to define a flat  
10 intermediate section for polishing said surfaces (21), at least one roller (17') being rotated by a motor, wherein said external abrasive layer (11) is divided into a plurality of sectors (13) adjacent and at mutual contact, defined by transverse cuttings with respect to the longitudinal direction  
15 of said belt (100), characterized in that each of said sectors (13) has a width (A) measured in the longitudinal direction of said belt (100) smaller than the height (H) measured in the direction transversal to the surface of said belt (100) and smaller than the radius (R) of said return rollers (17, 17')  
20 and is deformable under the polishing pressure.

14) Device (10) according to claim 13 characterized in that said sectors (13) made of abrasive material have a substantially parallelepiped section projecting radially from said internal layer (18) of said belt (100), said sectors  
25 (13) being provided with first lower ends constrained to said internal layer (18) in mutual side contact and with second free ends opposite to said constrained ends.

15) Device (10) according to claim 14 characterized in that it comprises means for guiding said flat intermediate polishing

section for guaranteeing contact of a plurality of said sectors (13) against the surface (21) to be polished.

16) Device (10) according to claim 15 characterized in that said means for guiding said flat intermediate section for  
5 polishing said surfaces (21) comprise a sliding block (19) operating on the internal surface of said internal layer (18) of said belt (100).

Fig.1

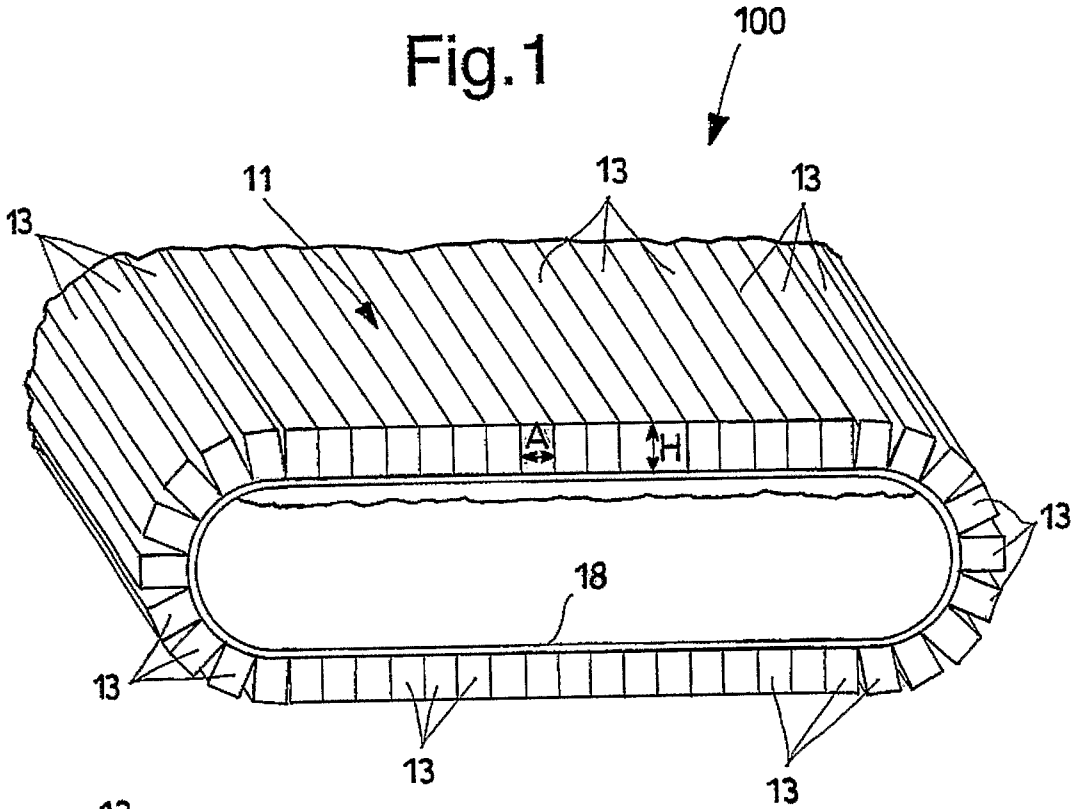

Fig.3

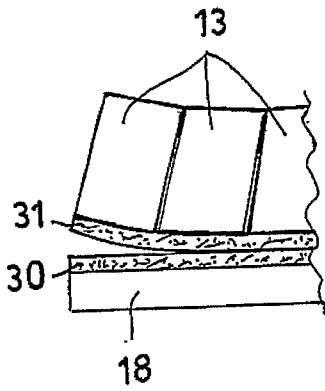
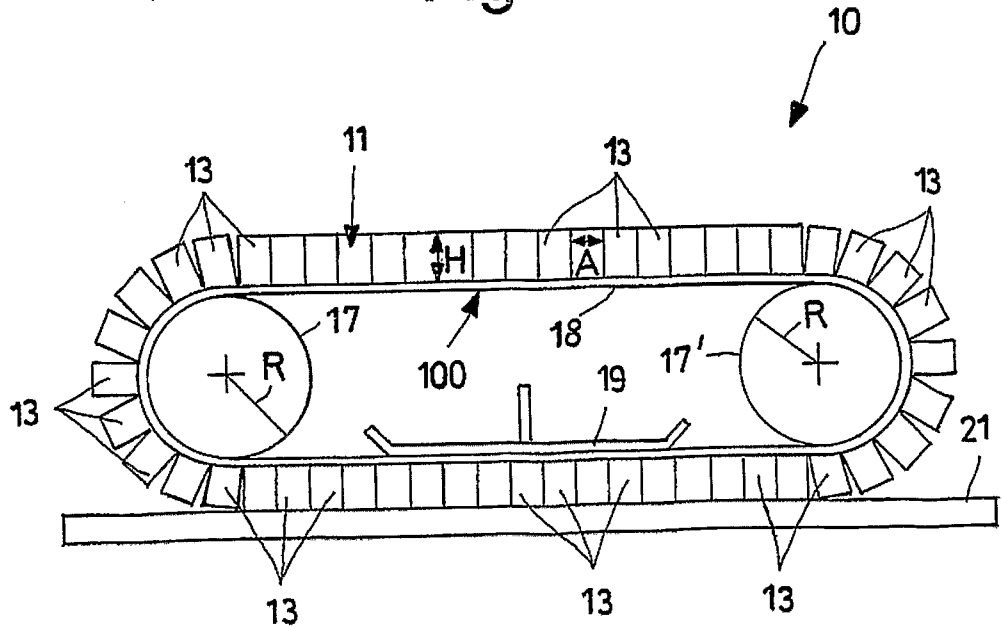

Fig.2



2/2

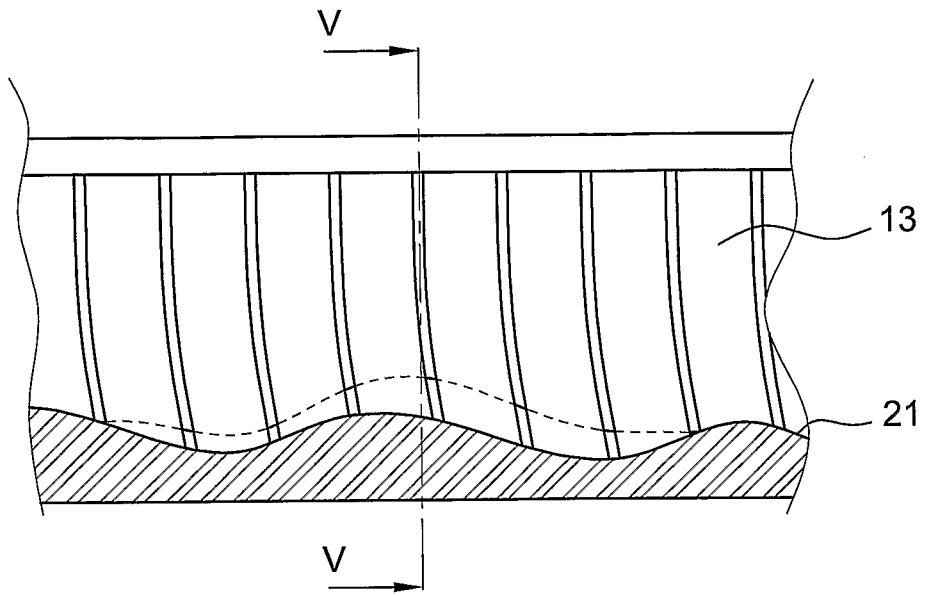

Fig. 4

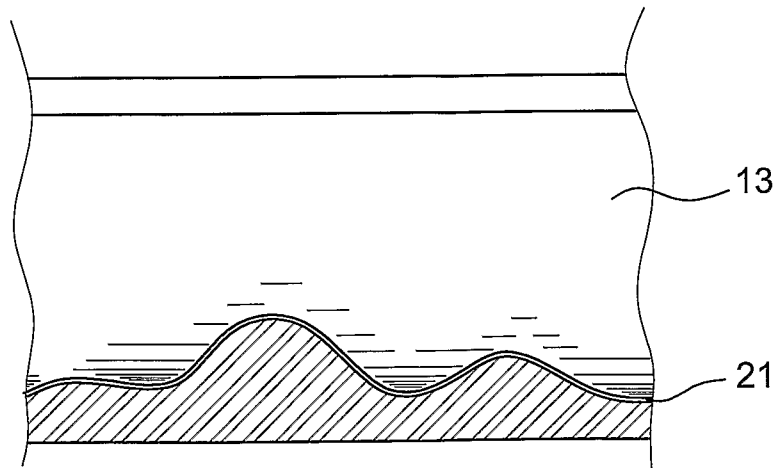

Fig. 5