

WITNESSES

W. J. D. New
M. Regier

INVENTOR

John D. Murray
By [Signature]

his ATTORNEYS

J. D. MURRAY.
 SAND BLAST APPARATUS.
 APPLICATION FILED JUNE 3, 1908.

998,111.

Patented July 18, 1911.

4 SHEETS—SHEET 2.

Fig. 3

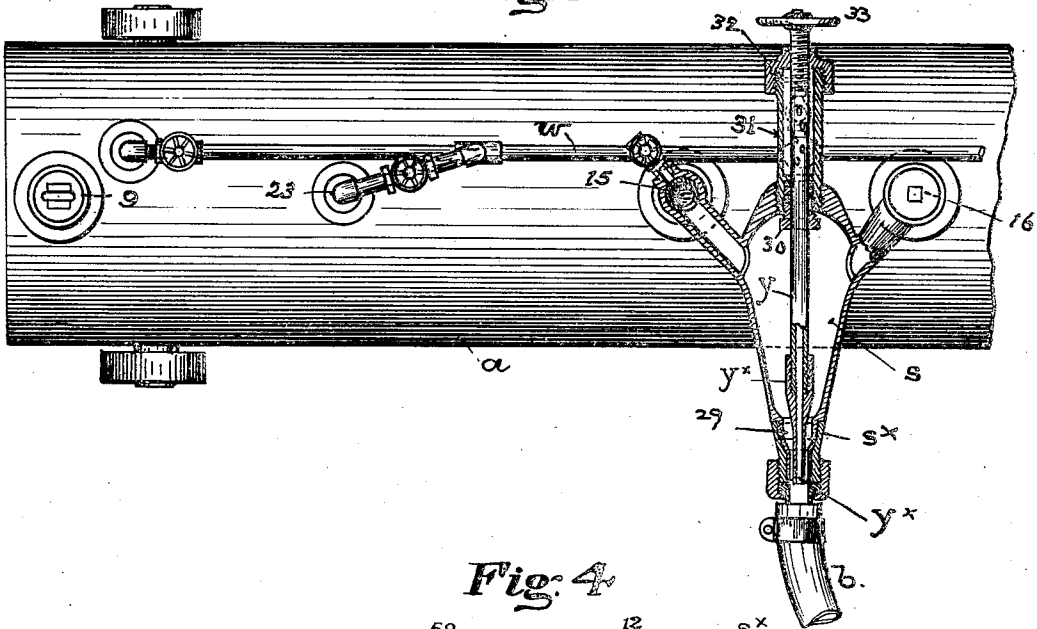
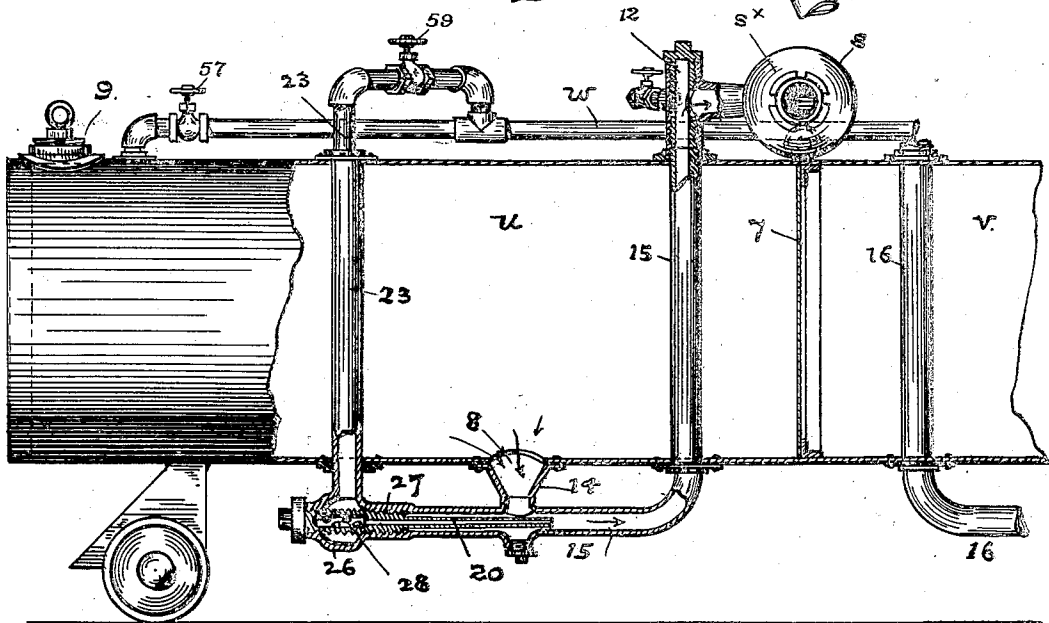

Fig. 4



WITNESSES

Wm. J. D. New
M. Regner

INVENTOR

John D. Murray
By E. G. Gou

his ATTORNEYS

J. D. MURRAY.
 SAND BLAST APPARATUS.
 APPLICATION FILED JUNE 3, 1908.

Patented July 18, 1911.

4 SHEETS-SHEET 3.

998,111.

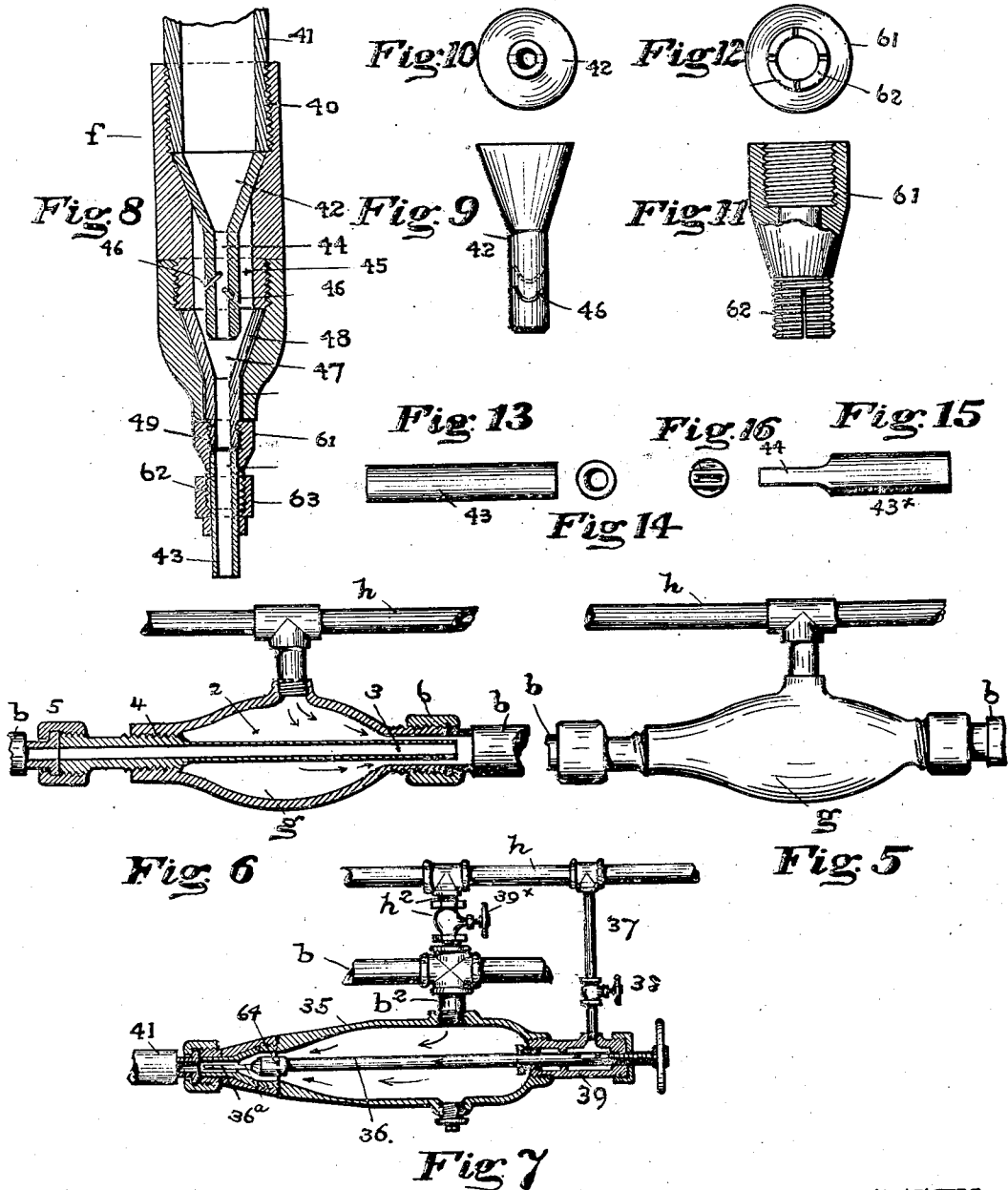

WITNESSES

Wm J. Drew
M. Regner

INVENTOR

John B. Murray
By C. Gordon
 his ATTORNEYS

J. D. MURRAY.
 SAND BLAST APPARATUS.
 APPLICATION FILED JUNE 3, 1908.

998,111.

Patented July 18, 1911.

4 SHEETS—SHEET 4.

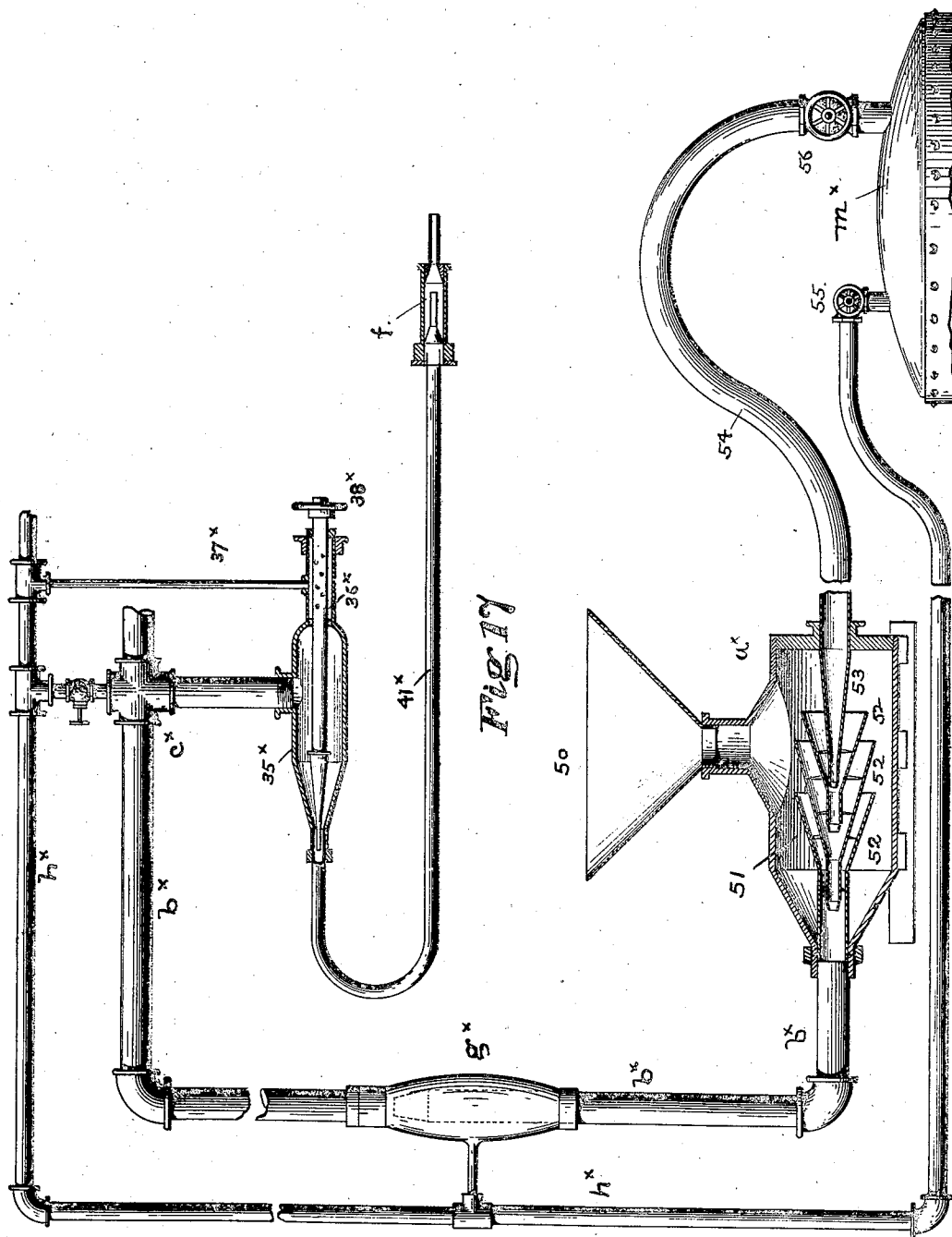

WITNESSES.

Arthur L. Lee.
 M. Regner

INVENTOR.

John D. Murray
 Ray E. Egan

his Attorneys.

UNITED STATES PATENT OFFICE.

JOHN D. MURRAY, OF SAN FRANCISCO, CALIFORNIA.

SAND-BLAST APPARATUS.

998,111.

Specification of Letters Patent.

Patented July 18, 1911.

Application filed June 3, 1908. Serial No. 436,407.

To all whom it may concern:

Be it known that I, JOHN D. MURRAY, a citizen of the United States, and a resident of the city and county of San Francisco and State of California, have invented new and useful Improvements in Sand-Blast Apparatus, of which the following is a specification.

This invention relates to improvements made in apparatus or appliances for scouring, cleaning, cutting, abrading or finishing surfaces of wood or metal by what is technically termed the "sand blast."

The invention has for its object to provide a sand-blast apparatus of large capacity for doing work on a large scale and under conditions where the surfaces to be operated on, or the work to be done, may be situated above the apparatus at a considerable distance from the ground, or from the place where the supply-tank and the air-compressing plant are stationed.

A further object of the invention is to provide means for moving the sand or other solid material through a conducting-pipe for a considerable distance horizontally, or for raising it through a perpendicular conductor by pneumatic pressure applied under such conditions that any liability of clogging or choking the material will be overcome and the material will flow to the sand-blast nozzles under uniform pressure when the jets are working at considerable distance from the supply.

A further object of the invention is to provide means for producing continuous progression or travel of the abrading substance or material through a closed conductor under varying conditions in the bulk or quantity of solid material carried by the air, and for conveying the same either horizontally or perpendicularly, for a considerable distance without liability of choking or obstructing the passages.

The invention has for its object also to improve the delivery nozzle of the apparatus in several points, particularly with the view to secure a regular discharge of the material in a stream of uniform character; also to afford facility for repairing or renewing the parts of the nozzle that are subject to wear.

To these ends my said invention comprises certain novel parts and combination of parts producing an improved machine or apparatus for operating with the sand-blast, all as hereinafter described at length and point-

ed out in the claims at the end of this specification.

Figure 1 of the drawings represents in elevation the complete machine or apparatus of my invention for doing work with the sand-blast. Fig. 2 is a transverse sectional-view on an enlarged scale of the coupling chamber on the supply tank to which the conducting-pipe or hose is coupled; the same showing the coupling-chamber in side-elevation and the upper portion of the tank in transverse section. Fig. 3 is a plan or top-view of the supply-tank and the coupling-chamber, the latter being shown in horizontal section. Fig. 4 is a side-elevation of Fig. 3, with the side of the tank partly broken away to expose the parts inside. Fig. 5 is a side-view on an enlarged scale of one of the accelerating nozzles in the length of the hose between the source of supply for the sand and the sand-blast nozzle. Fig. 6 is a longitudinal sectional view of Fig. 5. Fig. 7 is a longitudinal sectional-view of the last one of the accelerating devices in the line of the hose to which the sand blast nozzle is coupled. Fig. 8 is a longitudinal sectional view on an enlarged scale of the sand-blast nozzle through which the abrading material is applied and directed against the surface to be treated. Fig. 9 is a side-view of the removable tip of the nozzle shown in Fig. 8. Fig. 10 is an end-view of the tip. Fig. 11 is a side-view of the split sleeve or part that confines the removable tip in place, and Fig. 12 is an end-view of the sleeve. Figs. 13 and 15 show two forms of detachable tip for the nozzle, and Figs. 14 and 16 are end views respectively of the parts represented in Figs. 13 and 15. Fig. 17 illustrates a modification of my invention designed to provide a sand-blast apparatus of a more portable character than the complete apparatus shown in Fig. 1.

It is obvious that in the application of sand blast to the various circumstances of use, such as cleaning the hulls and other parts of marine vessels, the walls of buildings and various kinds of constructive material employed in the arts, to remove paint oxid scale, dirt or discoloration, that the apparatus employed has to be greatly modified in extent and detail.

The apparatus shown in the drawings herewith and forming a part of this specification consists in so far as I am able to

illustrate it, a normal arrangement of sand blast apparatus, and is an evolution or elaboration of such apparatus as is described in my previous Letters Patent, namely: Letters Patent No. 773,665, dated November 1st, 1904; No. 783,218, dated February 21st, 1905 and No. 818,776, dated April 24th, 1906, all in sand blast apparatus.

The sand employed is sometimes of two grades of fineness, which for reasons not very well understood produces a better and more rapid effect, supposedly because the larger grains fracture and the finer ones remove obdurate scale. The horizontal position of the tank or receiver *a* causes a nearly equal gravity pressure in the several compartments; the mobility of the dry sand causing it to act as a fluid and in proportion to the head.

In the complete apparatus of my invention the supply-tank *a* is of sufficient capacity to supply several sand-blast nozzles, and provision is made for varying the number of nozzles and for regulating the supply or "feed" of the material, according to the number of nozzles in use at one time. For this purpose the last section *c* in the line of hose *b* is provided with coupling-sockets *e* at intervals along the pipe to each of which connection of a sand-blast nozzle *f* can be made. This last section being formed of a rigid pipe it can be suspended from points of support along the line of work by means of slings *t*, as illustrated in Fig. 1, or by other supporting means that will permit the pipe to be shifted or moved from point to point as the work is carried forward.

An important feature in sand-blast apparatus of my invention consists in introducing at different points in the passages and conductors traversed by the stream of abrading material, a jet of compressed air, as a means both of augmenting the working pressure at those points where it may be necessary or desirable to accelerate the movement, or increase the pneumatic pressure in the conductor; also at other points in the line of travel where there is liability of the material choking or obstructing the conductor; as, for example, at or in the vicinity of the outlet-spout through which the material passes from the supply-tank into the line of hose, or the conducting passages leading from the tank to the hose, and in the outlet-passage from the coupling-chamber. These accelerating jets, as I have termed them, are either supplied from a separate source, or directly from the compressor that furnishes the air from the supply-tank. Usually the nozzles *g* are supplied from an equalizing tank *m* connected with the air-compressor through a line of pipe or hose *h*; the tank *m* being itself connected with the air-compressor by a hose *p*.

In the nozzles *g* shown in the details Figs. 5 and 6 the air in the chamber 2 will be under substantially the same pressure as that in the storage-tank *m*, and being forced through the annular space between the nozzle 3 and the surrounding walls of the chamber 2 it will impinge against the sand-charged stream issuing from the end of the nozzle and thereby increase the force or pressure above that which comes from the supply-tank.

The nozzle 3 is fixed in the chamber 2 by a threaded joint 4, and a screw-coupling 5 connects one end of the tube 3 with the conducting-hose *b* on one side, but at the other end the chamber and the conductor are connected together by a threaded sleeve 6. This construction permits the nozzle 3 and its casing or chamber to be readily removed for renewing or cleaning the parts. It also permits the number of accelerating nozzles to be increased or reduced, according to the requirements of the work, by employing sections of pipes, or conductors, of different lengths. In those situations where the material has to be elevated perpendicularly to a greater height as the work goes on, or under other conditions where it is necessary to increase the pressure in the conducting hose at different points in its length, the number of nozzles *g* can be varied to suit the needs of the work. In the complete apparatus of my invention similar nozzles are placed in the conducting-passages at the outlets in the bottom of the tank to prevent the passages from becoming checked or obstructed, and with that object to insure a continuous movement of the material through the conductors, and an effective pressure at the point of delivery regardless of the length of the line of hose.

The interior space of the tank *a* is divided by a partition 7 into separate compartments *u-v*, each having an opening in the top closed by a removable hand-pole plate 9 for introducing the sand, and an outlet in the bottom through which the material passes into and is conveyed by a conducting pipe or passage to the coupling-chamber *s* on the top of the tank. The last-named chamber is connected with the compartment *u* by a pipe 15 carried from the outlet 8 through the body of the tank upward and out through the top, and with the compartment *v* by the pipe 16 leading from the outlet 10. Valves 12-13 are provided for shutting off either compartment from the coupling-chamber so as to take the abrading material from one compartment while the other is being charged. This combination of a common coupling-chamber with the two compartments, and the means provided for connecting and disconnecting the compartments one separately of the other, enables the apparatus to be kept in operation

without shutting off the sand-blast nozzles when the supply-tank is to be recharged; for the pressure can be shut off from one compartment as often as it becomes necessary to open and recharge it with material, without interrupting the supply to the nozzles from the other compartment. This arrangement has the advantage, further, of permitting the use of two different grades or kinds of abrading-material either alone or together on the same work; to which end the compartment *u* can be charged with a different material from that contained in compartment *v*, and the coupling-chamber then be supplied first with material from one compartment, and afterward from the other compartment, by opening or closing the valves in the required order. Two kinds of material may be used together, also, by taking the supply simultaneously from both compartments, and by this means it is possible to vary the character or quality of the jets delivered at the sand-blast nozzles according to the needs of the work.

A nozzle 20 in the tube or passage 15 that connects the outlet-spout of the compartment *u* with the coupling-chamber *s* on the top of the tank, and another nozzle of the same character in the corresponding passage 16 that intersects and extends across the spout 18 under the other compartment *v* of the tank, are arranged to deliver jets of air in the same direction in which the material is moving, and thereby raise the pressure at those points where it may be required.

For supplying air to the nozzles at the outlets 8—10, a pipe 23 is carried from the pipe *w* on the top of the tank downward through the center of each compartment to the nozzle-casing under the outlet, where the pipe 23 and the nozzle-casing 15 join together in a chamber 26 that is somewhat larger than the butt end of the nozzle 20 which it incloses, and is provided with a screw-threaded socket 27 for the nozzle. The latter has a screw-thread fitted to the socket to form a tight joint therewith when screwed in place, and in the portion inclosed by the chamber it has perforations 28 through which the air passes into the nozzle. An ejector *y* in the coupling-chamber is similarly arranged, but instead of taking the air from the same source as the nozzles in the outlets under the tank, I prefer to connect the nozzle *y* directly with the tank *m* and employ the pressure in that tank to increase the force of the outgoing stream of material where it passes into the conducting hose *b*.

The coupling-chamber *s* and its ejector-nozzle are constructed with the view to facilitate repairs to the parts, and the renewal of those parts which are exposed to the greatest cutting action or wear of the ma-

terial. This is the case particularly with the throat of the outlet-passage in the neck of the coupling-chamber, and with the tip of the ejector. Both the tip of the ejector, and the lining 29 of the outlet are made detachable.

The stem *y* of the ejector-nozzle *y*^x extends through a stuffing-box 30 in the back wall of the chamber, and its butt end outside the chamber is surrounded by a tubular casing 31 having a screw-cap 32 in the end in which is a threaded socket for the end of the tube *y*. The latter extending through the cap is provided with a hand-wheel 33 for adjusting the nozzle in the throat of the chamber.

For the purpose of replacing the wearing surface of the outlet, the contracted neck *s*^x of the chamber is a separate piece attached to the body by a screw-joint, and its inner surface or lining is a loose sleeve 29 removably fitted to the throat of the chamber, so as to be removed when worn and a new lining substituted for it.

Air is supplied to the casing 31 from the tank *m* through a hose 34 which is coupled to the connection 65 provided for that purpose on the stationary air-pipe *w* on the supply-tank. Through these connections and conductors all the compartments and the nozzles also receive air from the tank *m*—the pressure being regulated in the compartments *u*—*v* by means of the valves 57—58 on the pipe *w*, and in the several nozzle-casings or chambers by the valves 59—60 in the pipes 23—25. Where the nozzle-blast *f* is being used at a considerable distance from the tank *a* and the compressed air-tank, a steady and even jet may be insured by connecting the ends of the conductors *b*—*c*—*h* with an equalizing tank or chamber.

The sand-blast nozzle *f* is of novel construction in several features, that have for their object chiefly to increase the durability of the parts and passages in which the jet of abrading material is formed and the tip or part through which it is discharged.

The construction of these parts will be understood more clearly by referring to the details Figs. 8 to 16.

From the threaded socket 40 in the butt end of the nozzle to the front end in which the tip 43 is fixed, the interior space is divided by a tapered nipple 42 into a central passage 44 forming a contracted continuation of the connected tube or hose 41, and an annular space 45 surrounding the nipple and extending beyond the end of that part in a contracted throat or passage 47 of about the same dimensions diametrically as the tip 42. The part 48 is a loose sleeve removably fitted to the chamber and forming a wearing surface or lining that can be re-

placed by a new one when worn. Being of tapered form and provided with a screw-threaded end 49 extending beyond the end of the nozzle-body, it is drawn forward to a close seat in the surrounding chamber when the sleeve or coupling-member 61 is screwed on. A split socket 62 on the end of the part 61 is screw-threaded externally for a nut 63, by means of which the detachable tip 43 is clamped in the socket on being inserted at the front end. Separate orifices of different forms, can be used from time to time as the character of the work may call for varying forms of jet, by removing one style of tip and fixing another in place in the socket. Figs. 13 and 15 illustrate two different styles of tips for that purpose. The tapered nipple 42 in this nozzle is of novel character in having several forwardly inclined slits 46 in its outer walls, so arranged with relation to the walls of the surrounding annular space 45 and of such size or width that relatively thin jets or streams of air only will escape and be projected against the surrounding walls, without carrying through the slits particles of the abrading material. The effect of these outwardly flowing forwardly inclined jets escaping through the slits above described, and thereby maintaining a constant flow of air in a thin stream or film against and over the walls surrounding the delivery-end of the nipple, is to modify or soften the contact of the stream of abrading-material at its point of delivery where it leaves the end of the nipple, and thus reduce the wear on the surrounding walls of the passage. The form of this nipple 42 is shown in Figs. 9 and 10. These features of construction are adapted to increase the durability of the nozzle, and to improve its effectiveness in operation in delivering a well defined jet without scattering or wasting the material. An accelerating jet is also interposed between the nozzle body and the conductor from which it takes its supply, as a means of increasing and varying the pressure in the sand-blast nozzle over that which is due to the pressure in the supply-tank and the hose. This additional pressure regulating means consists of the receiving-chamber 35 connected with the air-pipe h by a coupling, and containing a valve 64 having a hollow stem 36 the butt end of which extends through a tubular casing 39 on the end of the chamber 35. The casing is of larger diameter than the stem of the nozzle and is connected with a source of pressure by means of the tube 37 in which is a pressure-regulating valve 38. In the butt end of the valve-stem are perforations to admit the air or steam into the hollow-stem 36. The valve 64 has a conical head fitted to a seat of corresponding form in the outlet-passage, and from the end of the valve extends a tubular nozzle 36^a, through

which the air or steam is delivered into the outlet.

The casing 39 is connected with the air-pipe h by the tube 37 and the chamber 35 is connected with the conductor b by a short pipe b^2 through which the material enters the chamber. Provision is made for introducing air from the pipe h into the chamber 35 in addition to that which passes through the conductor, by connecting the chamber with the pipe h through a tube h^2 . This last mentioned tube is carried through the connection b^2 thereby reducing the number of apertures and couplings in the chamber. The pressure supplied through this connection is regulated by a valve 39^x.

The more simple form or construction of sand-blast apparatus illustrated in Fig. 17 is of a more portable character than the apparatus of my invention above described; being adapted for operating on a smaller scale and under conditions calling for a relatively light pressure and a jet carrying a fine abrading substance. In this portable apparatus the compartment 51 is fed with the abrading-material through the open hopper 50, and the material is forced into the conductor b^x by the air taken from the tank m^x acting through the nozzle 53 and the cones 52 of the injector in the chamber 51. The supply-tank a^x is therefore not under pressure as are the compartments $u-v$ in the supply-tank a , but in other respects this more simple form of the apparatus is similar to the machine represented in Fig. 1; the arrangement of accelerating nozzles g^x in the line of conductors $b^x h^x$ in and the coupling-chamber 35^x to which the sand-blast nozzle f^x is connected being practically the same.

Steam pressure may be substituted for air in the chambers of the nozzles g in the line of conducting hose. It can be used to advantage in place of air, particularly in the last chamber 35, to which the nozzle f is coupled, as the effect of introducing steam into the material at that point in the conductor is to condense the fine dust which otherwise becomes a source of annoyance and discomfort to the workman.

What I claim is:—

1. In sand blast apparatus, a main tank or receiver containing abrading material disposed in compartments, each compartment having a controllable connection to discharge ways for sand and air at the bottom, a conducting pipe therefrom to the discharge nozzles and in conjunction therewith, a second or reinforcing pipe of air under higher pressure and connections to the main pipe as rendered necessary by length or obstruction of the latter, substantially as specified.

2. In a sand blast apparatus, a main tank or receiver to contain air under pressure and

abrading material, compartments therein and connections from these compartments to a main pipe leading to abrading discharge nozzles, a pipe conducting air under pressure to the several compartments, a separate air pipe under a higher pressure parallel to the first or main pipe and controllable connections between the two lines of pipes so the supply of air can be increased as necessary or desired, substantially as described.

3. In sand blast apparatus, a portable main tank or receiver with compartments for sand and air under pressure, outlets at the bottom of these compartments for air and sand and a main pipe connecting to nozzles, in combination with a fixed auxiliary tank or receiver containing air under a superior pressure and connections from this to the main conducting discharge pipe at points where the greater air pressure is required, substantially as specified.

4. In sand blast apparatus, a supply of sand or other abrading material and air under pressure disposed in compartments of a main tank or receiver, pipes leading there-

from to nozzles to apply the abrading material, a second tank or receiver connecting to a second line of pipes containing air under a higher pressure, and a controlling or reducing valve to regulate the pressure in this secondary receiver and pipe line and controllable connections between the two pipe lines by which the force of the air and sand can be regulated at the nozzles, substantially as specified.

5. In sand blast apparatus, a main tank or receiver containing air under pressure and abrading material, pipes therefrom to nozzles for applying the abrading material, a second tank or receiver containing air under a superior pressure and a system of pipes therefrom with controllable connections to the nozzle pipes at various points by which the air pressure can be augmented as necessary and valves to control the volume and degree of the supplementary air pressure, substantially as specified.

JOHN D. MURRAY.

Witnesses:

EDWARD E. OSBORN,
M. REGNER.