

D. KENNEDY.

Improvement in Machines for Facing the Ends of Columns.

No. 129,568.

Patented July 16, 1872.

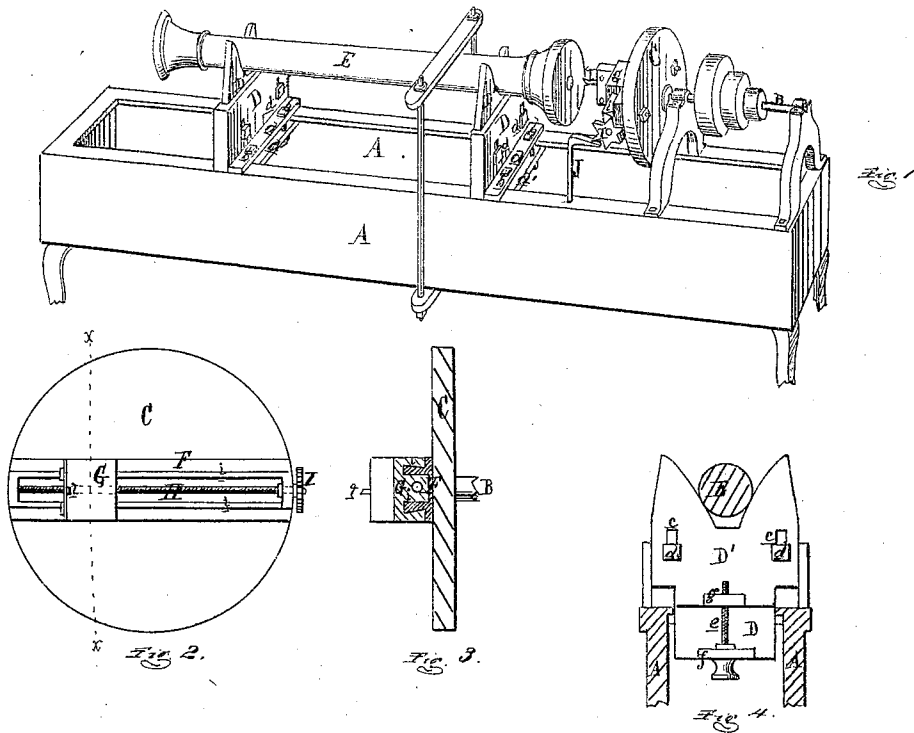

ATTEST:

H. F. Everts,
W. J. Sprague

INVENTOR:

David Kennedy,
per attorney
W. J. Sprague

UNITED STATES PATENT OFFICE.

DAVID KENNEDY, OF DETROIT, MICHIGAN, ASSIGNOR TO KENNEDY & GREIG,
OF SAME PLACE.

IMPROVEMENT IN MACHINES FOR FACING THE ENDS OF COLUMNS.

Specification forming part of Letters Patent No. 129,568, dated July 16, 1872.

To whom it may concern:

Be it known that I, DAVID KENNEDY, of Detroit, in the county of Wayne and State of Michigan, have invented a new and useful Improvement in Devices for Facing the Ends of Iron Columns; and I do declare that the following is a true and accurate description thereof, reference being had to the accompanying drawing and to the letters of reference marked thereon and being a part of this specification, in which—

Figure 1 is a perspective view of a lathe fitted with my improved devices. Fig. 2 is an elevation of the face-plate fitted with my traversing tool-holder. Fig. 3 is a cross-section on the line *x x* in Fig. 2; and Fig. 4 is an elevation of one of the adjustable rests, showing the lathe-bed and column in cross-section.

Similar letters of reference indicate corresponding parts in the several figures.

The nature of this invention relates to certain devices to be attached to an iron-turning lathe, by means of which the ends of iron columns may be quickly and accurately faced and with a small expenditure of power, inasmuch as the column does not require to be revolved, as heretofore has been the case. The invention consists, first, in the novel and peculiar construction of a pair of adjustable *V*-rests to be attached to the lathe-bed for centering and supporting the column while its end is being faced up; and, secondly, in the peculiar traversing tool-holder sliding in dovetail ways on a cross-slide attached to the face-plate of the lathe, the feed-screw of the rest being provided with a star-wheel, which, through a "kicker" on the lathe-bed, gives the tool-holder the necessary cross-feed in the rotation of the face-plate.

In the drawing, *A* represents a lathe-bed, *B* the head-spindle, and *C* the face-plate, all of the ordinary construction. To the lathe-bed I secure two *V*-rests, each of which is in two parts. The lower one, *D*, is provided with a flange, *a*, extending across the back horizontally, and resting on the bed, as do the ends of the part *D*. By means of a clamping-plate, *a'*, under the ways of the lathe, and the bolts *b* passing through it and the flange or angle-iron *a*, the part *D* may be securely fastened to the bed. The other part, *D'*, is in the general form of a *V*-rest, and is secured to the face of

the part *D* by two bolts, *d*, passing through vertical slots *c* cut in the rest, so that the latter may have a vertical adjustment, which is effected by a screw, *e*, passing through an opening in a lateral projection, *f*, at the bottom of the part *D*, and threaded through a screw-hole tapped through a similar lateral projection, *g*, at the bottom of the rest *D'*. The lower end of the screw is provided with a hand-wheel, and above the projection *f* there is secured to it a collar. The sides of the part *D* are flanged to form ways in which the rest *D'* moves. It is guided and supported so that when an iron column, *E*, is laid in the rests their *V*-rests will center it in a vertical plane, while the axis of the column is brought in line with the axis of the lathe-spindles by the screws *e* raising or lowering the rests, when the bolts *d* may be tightened up to secure the *V*-rests and take the strain off the screws. The column may be securely fastened in its rests by such a clamp as is shown in Fig. 1, but if it be a heavy casting its weight will hold it in place. The devices employed for facing up the end of the column next the face-plate I will now proceed to describe: *F* is a cast-iron cross-slide, with dovetail ways *i i*, and is bolted to the face-plate of the lathe diametrically across it. On the ways slides a traversing tool-holder, *G*, carrying an ordinary lathe-tool, *t*. The ends of the ways are connected by bridge-pieces, through one of which is passed a feed-screw, *H*, the other end of which is stepped in the other bridge-piece, first screwing through a threaded opening tapped longitudinally through the tool-carrier, which thus becomes its nut. On the projecting end of the feed-screw a star-wheel, *I*, is keyed, and on the lathe-bed is erected a standard, *J*, bent over at the top, and known as a "kicker," which turns the star-wheel and feed-screw the space of one tooth each time that the former sweeps by it in the rotation of the face-plate, and thereby giving the tool-holder its cross-feed, so that if the tool be brought to the center of the column and the lathe put in motion the metal will be removed from the end of the column in concentric circles, each subsequent circle described by the tool being a trifle greater in diameter than the preceding one, until the periphery is reached. The cutting-tool is secured and adjusted in the

tool-holder in the usual manner. After one end of the column is faced the latter may be turned end for end in the lathe, and the other end be faced in like manner, with a "double-header" lathe fitted with two of my traversing tool-holders. Both ends of the column may be faced up at one operation. As the heavy column does not revolve in being faced up, I am enabled to run my lathe at a high speed, saving much time and power and the labor of centering the column, as required in the ordinary way of doing it.

What I claim as my invention, and desire to secure by Letters Patent, is—

1. The cross-slide F, carrying the traversing

tool-holder G and feed-screw H, provided with the star-wheel I, in connection with the face-plate of a lathe and the "kicker" J or its equivalent for rotating the feed-screw, substantially as and for the purpose set forth.

2. The adjustable V-rest, consisting of the parts D D', the adjusting-screw e, lugs f g, and bolts d d, passing through the slots c c, the said part D being provided with any suitable means for attaching it to a lathe-bed, as and for the purpose specified.

DAVID KENNEDY.

Witnesses:

H. F. EBERTS,
H. S. SPRAGUE.