

- [54] **METHOD AND MEANS FOR WASHING EGGS, INCLUDING TILTED BRUSHES**
- [75] Inventors: **William S. Peppler**, Chappaqua, N.Y.; **Hans W. Beinssen**, Oyten, Germany
- [73] Assignee: **Diamond International Corporation**, New York, N.Y.
- [22] Filed: **Nov. 6, 1973**
- [21] Appl. No.: **413,336**

3,296,641 1/1967 Rose et al. .... 15/3.13  
 3,621,503 11/1971 Classen ..... 15/3.13

**FOREIGN PATENTS OR APPLICATIONS**

164,494 12/1933 Switzerland ..... 15/49 RB

*Primary Examiner*—S. Leon Bashore  
*Assistant Examiner*—Richard V. Fisher  
*Attorney, Agent, or Firm*—Karl W. Flocks

- [52] U.S. Cl. .... **134/6; 134/25 R; 15/3.14**
- [51] Int. Cl. .... **B08b 1/02**
- [58] Field of Search ..... 134/6, 9, 25 R, 32; 15/3.16, 3.14, 3.13, 3.12, 21 B, 21 R, 3.17, 49 RB

[57] **ABSTRACT**

Washing of eggs utilizing reciprocating brushes with the brushes tilted at an angle in the order of about 30°–60° from the vertical and having bristles of progressively shorter length in the direction of lean of the tilted brushes. The brushes are mounted for opposed reciprocation on mountings producing a natural frequency of vibration approximating the driven frequency.

- [56] **References Cited**  
**UNITED STATES PATENTS**  
 983,691 2/1911 De Long ..... 15/3.14

**9 Claims, 1 Drawing Figure**

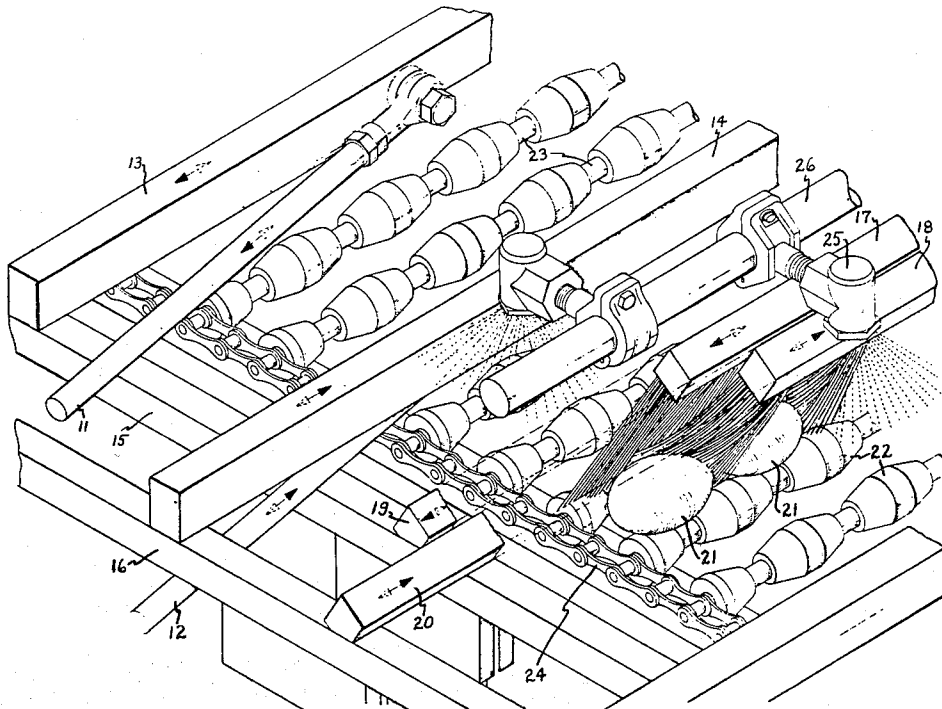

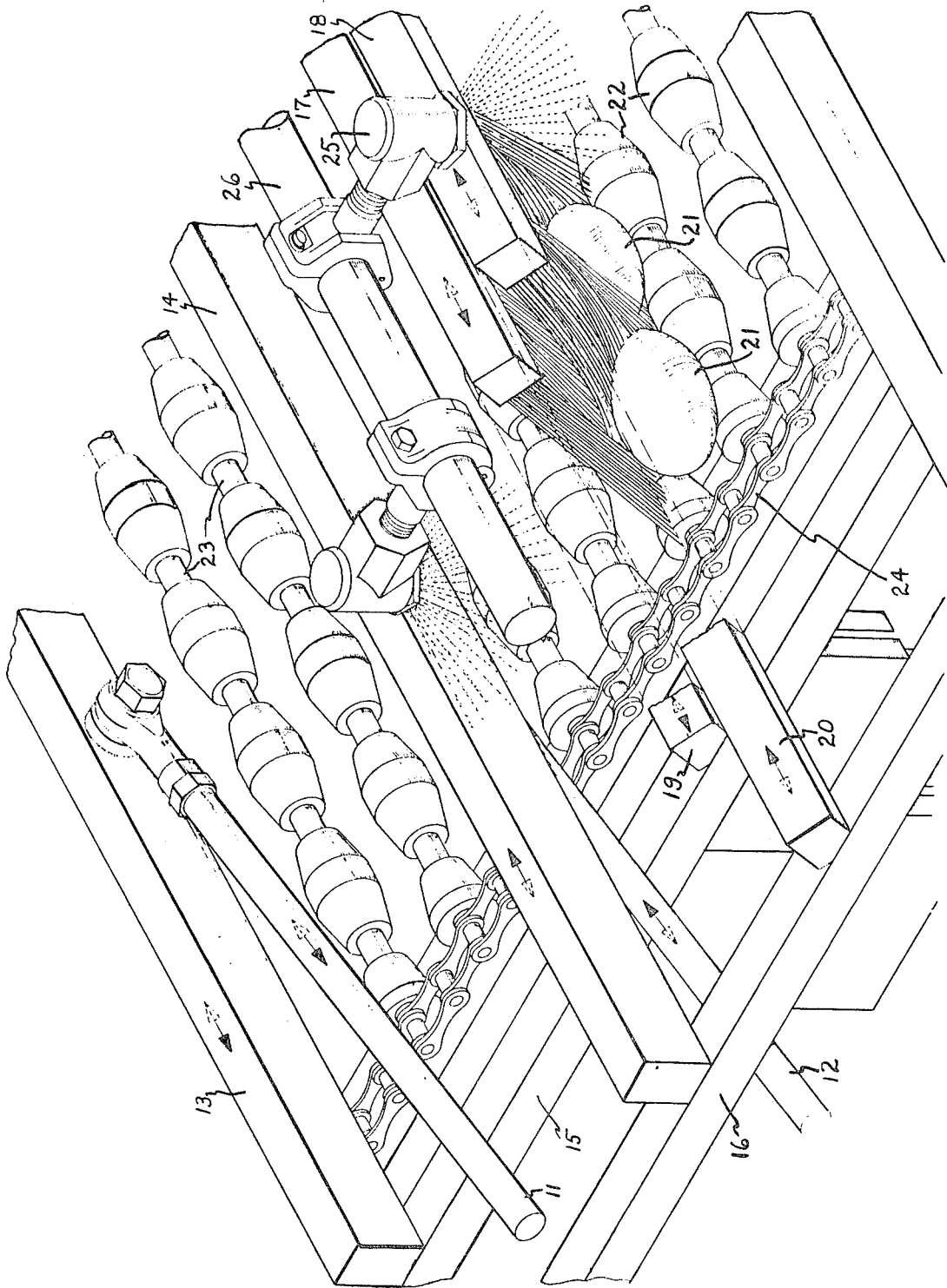

## METHOD AND MEANS FOR WASHING EGGS, INCLUDING TILTED BRUSHES

### BACKGROUND OF THE INVENTION

The invention relates to the washing of newly laid eggs and more particularly to the brushing of these eggs during the washing process.

Egg washers in the prior art have been found to have certain deficiencies especially where the brushing step is concerned.

In prior art egg washing devices the cleaning action is relatively slow because only a small portion of the egg is in contact with the brush at any one time, the brush stroke is long, and the oscillating frequency is limited by the unbalanced loading of the oscillating mechanism. The ends of the egg receive very little brushing action and so are difficult to clean. Also, relatively soft bristles must be used or the eggs will be pushed out of position and into collision. When it is attempted to alleviate this with washers having adequately high pressure jets of washing solution for blasting through dirt, it is found that the streams may penetrate exposed membrane and thereby destroy the egg contents.

Also, in the prior art, certain washers have an up and down oscillation of brushes with vertical bristles. These washers do an effective washing job but the action can break shells with vertical bristles possibly spearing exposed egg membrane causing loss of eggs.

Other washers use a variety of brush movements, including rotary but such are ineffective in cleaning because of a light touch and too rough on the eggs when a heavier touch is used.

### SUMMARY OF THE INVENTION

It is an object of this invention to perform the washing of the eggs quickly and efficiently.

It is another object of the present invention to avoid any action that would cause shell breakage from excessive pressure on the shell, or that would cause relative movement among the eggs that could cause egg to egg collisions.

It is a still further object of the invention to wash cracked eggs without puncturing the egg membrane thereby causing total loss of the egg.

In the present invention the above objectives are obtained by use of a structure maintaining a dynamically balanced system with strip brushes tilted from the vertical and always bent when in contact with an egg.

### BRIEF DESCRIPTION OF THE DRAWING

The above and other objects and advantages of the invention will become apparent upon full consideration of the following detailed description and accompanying drawing, wherein the sole FIGURE is a perspective view of a portion of the machine for washing eggs showing the present invention.

### DESCRIPTION OF THE PREFERRED EMBODIMENT

Referring to the sole FIGURE of the drawing, there is shown a section of a machine for washing eggs in accordance with the present invention.

Opposed eccentric drives (not shown) are connected to reciprocate each of lever arms 11 and 12 which are pivotally connected to transverse beams 13 and 14, respectively. The movement of levers 11 and 12 reciprocates

beams 13 and 14 in a horizontal plane in opposite directions, thereby causing a similar horizontal movement of frames attached thereto having longitudinal beams 15 and 16 as shown. Similar longitudinal beams not shown are similarly connected on opposite ends of transverse beams 13 and 14 to help complete the movable frames. The two frames are flexure mounted on spring supports (one side shown) to permit transverse oscillation and being driven by opposed eccentric drives thus maintain a dynamically balanced system. Stiffness of the flexure mountings is selected to produce a natural frequency of vibration for the brush frames that approximates the driven frequency.

Brushes 17 and 18 are mounted on transverse supporting beams 19 and 20, respectively, which have their ends attached to longitudinal beams 15 and 16, respectively, and thus are reciprocated transversely in a horizontal plane opposite directions over eggs 21. These eggs 21 are carried by rollers 22 carried on transverse rods 23 attached at their ends to chains 24 (only one side shown). Rollers 22, rods 23, and chains 24 form the conveyor for moving eggs 21 and slowly rotating them as they pass through the egg washer.

Strip brushes 17 and 18 are tilted approximately 30° from the vertical and positioned to always be bent when in contact with an egg so as to avoid column force adequate to spear an egg membrane through a cracked egg shell. Although illustrated at approximately 30° from the vertical, the brushes may be tilted even further from the vertical. A position of 60° from the vertical has still been found effective.

A fast washing action is accomplished by rapid oscillating reciprocation of brushes 17 and 18 in opposite directions. The bristles continually remove dirt loosened by the chemical action of the washing solution that flows down the brushes from spray heads 25 located above them and receiving their supply of solution through pipe 26.

Where cracked eggs are being washed prior to processing this invention is of particular importance. Conventional washers use a stabbing motion or an oscillating motion where the brush travels in the plane defined by the bent bristle. In the tilted brushes of the present invention, when the brush is oscillated horizontally the side of the bristles are used and there is no stabbing force from the ends of the bristles although considerable force is applied to the brush.

Also as shown in the Figure, the bristles of brushes 17 and 18 (note brush 17 in the Figure) are of unequal length transversely of the strip brush with decreasing length in the direction of the lean of the brush. This increases the effective action of the brush since it uses its end portions without the undesirable stabbing action discussed above.

It will be obvious to those skilled in the art that various changes may be made without departing from the scope of the invention and the invention is not to be considered limited to what is shown in the drawing and described in the specification.

What is claimed is:

1. A method of washing eggs comprising the steps of moving eggs on a conveyor beneath a pair of strip brushes tilted from the vertical position in order of about 30°-60°, horizontally reciprocating the brushes in opposite directions from each other while maintaining said

brushes in the position tilted from the vertical, while the eggs move thereunder, and simultaneously spraying a washing solution onto the eggs.

2. The method of washing eggs in accordance with claim 1, further characterized by said position of tilt of the brushes being approximately 30° from the vertical.

3. The method of washing eggs in accordance with claim 1, further characterized by spring mounting of said brushes, and driving the reciprocating brushes at a frequency approximately at their natural frequency of vibration due to their spring mounting.

4. A machine for washing eggs comprising means to apply a washing solution on the eggs, conveyor means to move the eggs being washed through the machine, at least one pair of brushes tilted from the vertical position in the order of about 30°-60° mounted above said conveyor means, means to reciprocate said brushes horizontally with each one of said pair of said brushes moving in an opposite transverse direction from the other one of said pair in relation to the direction of movement of said conveyor means.

5. The machine of claim 4, further characterized by said brushes having bristles of progressively shorter length in the direction of tilt from the vertical posi-

5  
10  
15  
20  
25  
30  
35  
40  
45  
50  
55  
60  
65

tion.

6. The machine of claim 4, further characterized by said means to reciprocate said brushes including transverse beams supporting said brushes, at least two movable frames supporting said brush supporting transverse beams, each of one of said pair of brushes being supported by a said transverse beam supported by one of said frames, and the other of said pair of brushes being supported by a said transverse beam supported by another of said frames, and means to move said movable frames in a reciprocal movement in opposite directions to each other.

7. The machine of claim 6, further characterized by said means to move said movable frames including lever means pivotally connected to each of said at least two movable frames, one of said lever means connected to an opposed eccentric drive from another of said lever means.

8. The machine of claim 6, further characterized by said movable frames mounted on spring flexure mountings.

9. The machine of claim 8, further characterized by said spring flexure mountings producing a natural frequency of vibration of said frames approximating the driven frequency of said frames.

\* \* \* \* \*