

(19) World Intellectual Property Organization  
International Bureau



(43) International Publication Date  
11 May 2006 (11.05.2006)

PCT

(10) International Publication Number  
WO 2006/048044 A1

(51) International Patent Classification<sup>7</sup>: H04Q 7/38, 7/32

(21) International Application Number:  
PCT/EP2004/052767

(22) International Filing Date:  
3 November 2004 (03.11.2004)

(25) Filing Language: English

(26) Publication Language: English

(71) Applicant (for all designated States except US): TELEFONAKTIEBOLAGET LM ERICSSON (publ) [—/SE]; S-164 83 Stockholm (SE).

(72) Inventors; and

(75) Inventors/Applicants (for US only): STUEMPERT, Martin [DE/DE]; Hundsbrunnentalstr. 22, 67691 Hochspeyer (DE). EWERT, Joerg, Christian [DE/DE]; Karl-Platz-Str. 22d, 41812 Erkelenz (DE).

(74) Agent: TONSCHIEDT, Andreas; Ericsson GmbH, Patent department, Ericsson Allee 1, 52134 Herzogenrath (DE).

(81) Designated States (unless otherwise indicated, for every kind of national protection available): AE, AG, AL, AM,

AT, AU, AZ, BA, BB, BG, BR, BW, BY, BZ, CA, CH, CN, CO, CR, CU, CZ, DE, DK, DM, DZ, EC, EE, EG, ES, FI, GB, GD, GE, GH, GM, HR, HU, ID, IL, IN, IS, JP, KE, KG, KP, KR, KZ, LC, LK, LR, LS, LT, LU, LV, MA, MD, MG, MK, MN, MW, MX, MZ, NA, NI, NO, NZ, OM, PG, PH, PL, PT, RO, RU, SC, SD, SE, SG, SK, SL, SY, TJ, TM, TN, TR, TT, TZ, UA, UG, US, UZ, VC, VN, YU, ZA, ZM, ZW.

(84) Designated States (unless otherwise indicated, for every kind of regional protection available): ARIPO (BW, GH, GM, KE, LS, MW, MZ, NA, SD, SL, SZ, TZ, UG, ZM, ZW), Eurasian (AM, AZ, BY, KG, KZ, MD, RU, TJ, TM), European (AT, BE, BG, CH, CY, CZ, DE, DK, EE, ES, FI, FR, GB, GR, HU, IE, IS, IT, LU, MC, NL, PL, PT, RO, SE, SI, SK, TR), OAPI (BF, BJ, CF, CG, CI, CM, GA, GN, GQ, GW, ML, MR, NE, SN, TD, TG).

**Declaration under Rule 4.17:**

— as to applicant's entitlement to apply for and be granted a patent (Rule 4.17(ii))

**Published:**

— with international search report

For two-letter codes and other abbreviations, refer to the "Guidance Notes on Codes and Abbreviations" appearing at the beginning of each regular issue of the PCT Gazette.

(54) Title: METHOD AND DEVICE FOR PROVIDING A MOBILE STATION WITH NETWORK NETWORK IDENTITY AND TIMEZONE (NITZ) INFORMATION

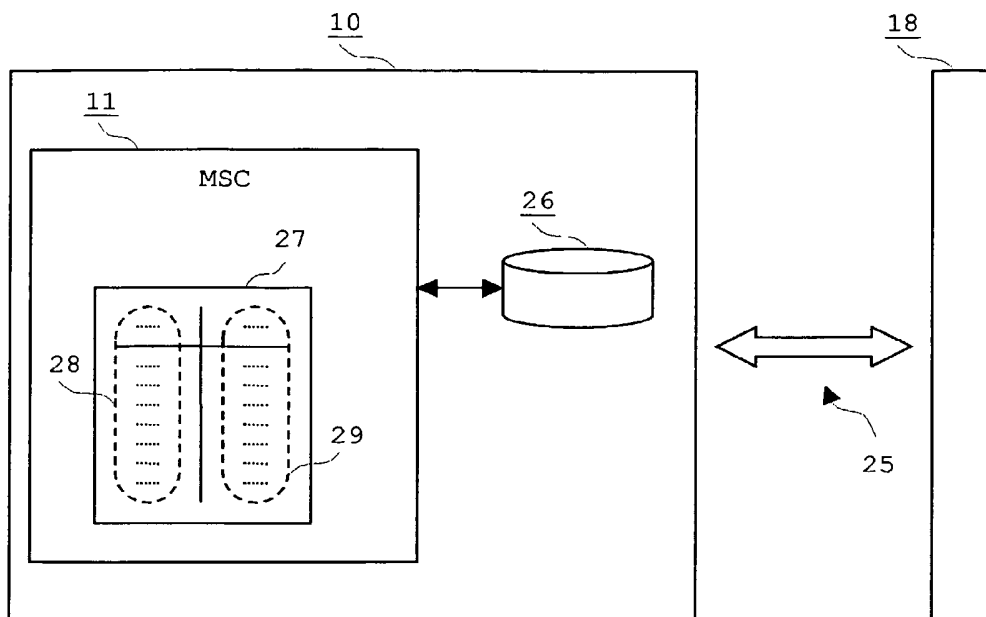

(57) Abstract: The present invention relates to a method and a device - unit (11) - capable of performing the method for providing a mobile station (18) engaged with a telecommunications network (10) with data that is not identical throughout the whole network (10), where a table (27) is maintained in at least one unit (11) of the network (10) associating location dependent data (29) indicative of a location of the mobile station (18) to data that is valid for the mobile station (18).

WO 2006/048044 A1

## METHOD AND DEVICE FOR PROVIDING A MOBILE STATION WITH NETWORK NETWORK IDENTITY AND TIMEZONE (NITZ) INFORMATION

## Field of the invention

The present invention relates to methods, use and devices for data transmissions over a telecommunications network by means of Network Identity and Timezone (NITZ) feature.

## Background of the invention

In recent years cellular telephones have become increasingly popular. A cellular telephone is just one example of what is referred to in telephone parlance as a "mobile station" (MS) or "mobile terminal". A mobile station can take on various forms other than a cellular telephone, including a computer (e.g. a laptop computer) with mobile termination capabilities. A mobile station comprises of a so-called mobile equipment (ME) and a subscriber identification module (SIM).

Telecommunication services are provided between a cellular telecommunications network and a mobile station over an air interface, e.g. over radio frequencies. At any moment, an active mobile station is in communication over the air interface with one or more units of the communications network such as base transceiver stations (BTSs). Base transceiver stations (BTS) in turn are managed by other units of the network such as base station controllers (BSCs), also known as radio network controllers (RNCs). A base station controller (BSC) together with its base transceiver stations forms a base station subsystem (BSS). The base station controllers of a base station subsystem are connected via further units of

the network, e.g. control nodes, to a core telecommunications network. Control nodes can take on various forms, depending on the types of services of networks to which the control nodes are connected. A well known embodiment of a control node is a mobile switching center (MSC), which is often associated with a visiting location register (VLR).

The network is described using GSM-type terminology. However, as is apparent to any person skilled in the art, the present invention may be employed in other radio communication networks, e.g. UMTS (Universal Mobile Telecommunications System), etc., as well. Therefore, the use of GSM-type terminology shall not be construed as limiting the scope of the invention. The mobile switching center in UMTS-type telecommunications networks is still denoted as mobile switching center (MSC). The equivalents of the base stations controller and the base transceiver station of GSM-type telecommunications networks however are denoted as radio network controller (RNC) and Node-B respectively in UMTS-type telecommunications networks.

An owner of a mobile station typically enters into a contract or subscription agreement with a service provider (e.g., a company which operates the telecommunications network through which the mobile station engages in telecommunications connections). As part of the subscription agreement, the mobile station is categorized as belonging to one of several access classes available on the network. Subscription data from the subscription agreement is stored in a record maintained e.g. in a home location register (HLR) for the mobile station. Each subscriber having a mobile station is assigned a unique International Mobile Subscriber Identify (IMSI). The interna-

tional mobile subscriber identity is stored in the subscriber identification module.

A mobile subscriber, that is to say the user of the mobile station, who roams freely within the network, is able to do so because the network stores information about a location of the mobile station. This makes it possible for the mobile subscriber to receive a call regardless of location. To keep the network up to date with the subscriber's location, the mobile station informs the network whenever it changes a location area (LA). This is called location updating. Location areas (LAs) are defined by location area identities (LAI), comprising a mobile country code (MCC), a mobile network code (MNC) and a local area code (LAC).

A base transceiver station broadcasts a location area information to a mobile station. A base station controller / radio network controller broadcasts a routing area (RA) and the location area (LA) to the mobile station. The mobile station uses the received mobile network code (MNC) and compares the value with a mapping table, which is stored either in the mobile equipment (ME) or in the subscriber identification module (SIM). The mapping table translates the mobile network code (MNC) into a text string, which can be displayed on the display of the mobile equipment (ME). The text string comprises an alphanumeric representation of the network identity (NI), e.g. "T-D1", "O<sub>2</sub>", etc.

The problem with this handling is that it is too static. Therefore there is no provision to account for changing names of the service providers or the actual branding for mobile stations (MS) on the market. Furthermore with communication networks jointly used by at least two service providers, the

subscriber is likely to be displayed with a wrong network identity (NI), e.g. "D1" instead of "O<sub>2</sub>" or vice-versa.

The 3GPP (3<sup>rd</sup> generation partnership project) specification TS 22.042 - Network Identity and Time Zone (NITZ), Version 5.1.0 published June 18 2003, describes a mechanism to transfer a network identity (NI) within a mobility management (MM) message towards the mobile station (MS). However, even with NITZ it is not possible to send different network identities to subscribers of different service providers.

#### Summary of the present invention

Therefore, it is object of the present invention, to provide a method and devices that enables mobile stations to display the correct network identifier or similar information in varying circumstances.

This object is achieved by the method of claim 1, the use of claim 6 and the unit of claim 7.

The invention introduces a method for providing a mobile station engaged with a telecommunications network that comprises a core network, a first access network and a second access network with a Network Identity and Timezone information. The method comprises the steps of detecting that a Network Identity and Timezone information shall be send to a mobile station, determining a location of the mobile station, determining a Network Identity and Timezone information value depending on the location of the mobile station and on an information related to a telecommunications service provider providing a subscription used by the mobile station, and

sending the Network Identity and Timezone information towards the mobile station.

In an embodiment of the invented method, a core network node maintains a table associating the information related to a telecommunications service provider to data that is used for determining the Network Identity and Timezone information-value.

The first access network can be associated to a first telecommunications service provider and the second access network can be associated to a second telecommunications service provider. In that case the information related to a telecommunications service provider can be an identification of a device of an access network that is used to serve the mobile station or an identification of a location area.

In an embodiment of the invention, the information related to a telecommunications service provider is an identification of the subscription.

The invention further introduces a use of Network and Timezone feature for transmitting information towards a mobile station. This is performed by replacing information that is usually sent in the Network Identity and Timezone information message by information that shall be transferred to the mobile station.

The invention further introduces a unit for a telecommunications network for providing a mobile station engaged with the telecommunications network, with a Network Identity and Timezone information value. Said network comprises a core network and at least two access networks, and the unit comprises an

input unit, an output unit, a location determining unit, a calculation unit for calculating a Network Identity and Timezone information value and a control unit. The Unit further comprises an association unit for associating information related to a telecommunications service provider to data that is used for determining a Network Identity and Timezone value by the calculation unit.

The information related to a telecommunications service provider can be referring to a least one unit of an access network used for serving the mobile station.

The information related to a telecommunications service provider can be a location area identity.

The information related to a telecommunications service provider can also be an international mobile subscriber identity.

It is advantageous that the invented method enables the NITZ feature in shared networks and ensures the displaying of the appropriate network identifier.

Further advantageous is the maintenance of a table in a core network node. Locating the table in the core network has the advantage that the table is centralised.

To identify a network by means of a device of an access network has the advantage that network identification is more reliable, as it is oriented at facts instead of settings.

To identify the network by means of a location area has the advantage that the sending of a NITZ at a location area update can be implemented in a very simple way.

The identification of a network to be displayed by means of an identification of a subscription enables to display an identification of a network of the service provider providing the subscription even in an access network of a different operator.

The use of the NITZ feature message as a container for information in general has the advantage that a further mechanism for sending information to be displayed to a subscriber is available.

The invention is based on realising that the network stores information where a mobile station is located when attached to the network. This information comprises for example data referring to the unit (the units) participating in the attachment of the mobile station to the network or data referring to locations covered by units of the network by means of the range of the radio transmission. The invention therefore proposes to use the location related data to select and transfer respective data which is not identical throughout the whole network, as is true for the network identity in a shared network, but is valid for the area indicated by the location related data. An example for data which is not identical throughout the whole network is local time information in a network covering more than one local time zones.

The essential advantage of the invention is that each mobile station receives data, which is valid and correct for that certain mobile station and/or location.

The invention as it is defined by the appending claims also involves, for networks comprising of a core network and a radio network, the transmission of the data which is valid for

the mobile station via at least one unit of the radio network. The transmitted data can for example be selected from a table provided at a unit of the core network.

The invention can also involve, for networks comprising a core network and a radio network, the transmission of the data which is valid for the mobile station by overwriting data which is not valid for the mobile station and which was sent from a unit of the core network, while the data which is valid for the mobile station is selected from a table provided at a unit of the radio network.

Obviously, other selection and/or transfer arrangements can be envisaged.

#### Brief description of the drawings

All the elements which are not required for the immediate understanding of the invention are omitted. In the drawing, the same elements are provided with the same reference numerals in the various figures, and in which:

- FIG 1 is a schematic view of a cellular telecommunications network;
- FIG 2 is a schematic view of the cellular telecommunications network with a special data transmission and
- FIG 3 is a block diagram of some units of a telecommunications network engaged in data transmission,
- FIG 4 depicts a flow chart of the method according to the invention, and
- FIG 5 depicts a unit according to the invention.

FIG 1 shows an example cellular telecommunications network 10. The network 10 comprises of a mobile switching center (MSC) 11, connected to one ore more base station controllers (BSC) 12, 13. The base station controllers 12, 13 in turn are each connected to one or more base transceiver stations (BTS) 14, 15, 16, 17. Each base transceiver station 14-17 builds an air interface to mobile station (MS) 18, 19. The mobile switching center 11 as well as one or several base station controllers 12, 13 represent the core network of the telecommunications network 10. The one or more base transceiver stations 14-17 as well as any mobile station 18, 19 attached to the telecommunications network constitute the radio network of the telecommunications network 10.

The network 10 depicted in FIG 1 is shown using GSM-type terminology. While the preferred implementation is described in the GSM context/application, the present invention may be employed in other radio communication networks, e.g. UMTS. The same applies for the following figures as well.

A base transceiver station 14-17 broadcasts (broadcast 20) a local area information (LAI) 21 including a mobile country code (MCC) 22 and a mobile network code (MNC) 23 to the mobile stations 18, 19 engaged with the particular base transceiver station 14. The mobile network code (MNC) 23 actually sent to the mobile station 18 is a special mobile network code, e.g. MNC-2, according to the base station controller (BSC) 12, 13 / base transceiver station (BTS) 14-17 broadcasting the local area information (LAI) 21.

On receiving the local area information 21 the mobile stations 18, 19 compare the received data, i.e. MNC-2, MCC, with

## 10

mobile network codes and mobile country codes (MNC, MCC) stored in a table in the subscriber identification module (SIM). The stored collection of MNC, MCC data for example comprises of the following exemplary entries:

```
MCC, MNC-1    →  "02"  
MCC, MNC-2    →  "T-D1"  
MCC, MNC-x    →  ...  
...
```

Therefore, both the mobile stations 18, 19 on receiving the local area information (LAI) 21 including the mobile network code MNC-2 will display the text string "T-D1" as the network identity on their displays. Thus, both the mobile stations 18, 19 display the same network identity even if they belong to different service providers. This is erroneous.

FIG 2 again shows an example cellular telecommunications network 10 as described beforehand in connection with FIG 1. The difference between FIG 1 and FIG 2 is that the telecommunications network 10 broadcasts (broadcast 20) the network identity (NI) 24 using the NITZ feature. NITZ is, unlike the "classical approach" as illustrated in FIG 1, not based on text strings stored in the mobile station 18, 19. With NITZ the text strings are directly transmitted to the mobile station 18, 19. This makes it possible for a serving telecommunications network 10 to transfer its current identity 24 to mobile stations 18, 19 and for the mobile station 18, 19 to store and use this information. This enables the accurate indication of network identities that are either newer than the mobile station 18, 19, i.e. the data stored in the mobile

station 18, 19, or have changed since the mobile station 18, 19 was manufactured or sold.

However, NITZ only allows one text string to be transmitted as network identity. Thus, with telecommunication networks 10 shared by at least two service providers all the mobile stations 18, 19 attached at the network 10 will display the same network identity when using NITZ. This is a shortcoming the invention tends to overcome.

The invention therefore provides the possibility to send different network identities 24 to mobile stations 18, 19 attached to the same network 10. A selection of the network identity 24 actually sent to a certain mobile station 18 is based on the location of that mobile station 18. To do so, data sent either by a mobile station 18 itself or on behalf of the mobile station 18 and comprising of data indicating the location of that mobile station 18 is analyzed by the network. The data sent by the mobile station 18 or on behalf of the mobile station 18 for example is data transmitted in connection with the so-called mobility management (MM) as shown in FIG 3.

Mobility management is concerned with all aspects of the mobility as well as identification and authentication of the subscriber. The underlying protocol enables transmission of mobility related data 25 between the mobile station 18 and the network 10, that is to say the core network, especially the mobile switching center 11. Mobility related data 25 is exchanged between a mobile station 18 and the network 10 when doing a location update. For updating the location of a subscriber a location area (LA) is stored in the visiting location register (VLR) 26, which is preferably associated with

## 12

the mobile switching center 11. Additionally an identifier referring to the base station controller 12, 13 from which the location updating has been received is stored either in the visiting location register 26 and/or the mobile switching center 11.

Therefore an association unit, for example implemented by means of a table 27, is maintained in the mobile switching center 11 associating different network identities 28 to one or more location dependent entries 29. In a preferred embodiment a location dependent entry 29 is referring to one or more elements of the core network. Therefore a certain table 27 according to the preferred embodiment is associating different network identities 28 to one or more base station controllers 12, 13 as subsequently depicted in an exemplary manner:

BSC-1	→	"Network Identity 1"
BSC-2	→	"Network Identity 1"
BSC-3	→	"Network Identity 2"
BSC-4	→	"Network Identity 2"
...		...

Thus, the network 10 is enabled to send a network identity to the mobile station 18 based on the elements 29 of the network 10 participating in the mobility management of the mobile station 18. If, for example, a certain base station controller 12 is involved in transferring the mobility related data 25 within the network 10, the mobile station 18 is expected to be located within an area covered by that base station controller 12 as well as to be attached to the network 10 via that base station controller 12. Therefore, if the network 10

## 13

is shared in a manner that a first base station controller 12 is operated by a first provider and a second base station controller 13 is operated by a second provider each using different network identities, the network 10 is able to send the respective provider's network identity to the mobile station 18 with regard to the location of the mobile station 18 which is derived from the elements participating in the mobility management of the mobile station 18.

In case that the operators only have the air interface separated, i.e. the base station transceivers 14-18, the network identification is based on the location area (LA) or on a base station area (BSA). The location area (LA) is an area served by one or more base transceiver stations 14-17 and a base station area (BSA) is an area served by just one base transceiver station 14-17.

The table 27 maintained in the mobile switching center 11 accordingly has the following form associating different network identities 28 to location dependent entries 29, where a location dependent entry 29 either refers to a location area (LA) or a base station area (BSA):

LA-1, LA-2, ... LA-100	→	"Network Identity 1"
LA-101, LA-102, ... LA-200	→	"Network Identity 2"

or

BSA-1, BSA-2, ... BSA-100	→	"Network Identity 1"
BSA-101, BSA-102, ... BSA-200	→	"Network Identity 2"

The analysis of the table 27 when containing data relating to location areas or base station areas is similar to that of the table containing data referring to the base station controllers 12, 13 involved as described beforehand.

Accordingly it can be said, that the table 27 maintained in the mobile switching center 11 is of the general form where an entry, i.e. the network identity 28, is associated with a set of location dependent data 29. The location dependent data 29 is either an identifier referring to the base station controller 12, 13 used when attaching with the network 10 or an identifier referring to the location area/base station area where the mobile station 18 is located or any other data indicating the location of the mobile station 18.

In an alternative embodiment of the invention the association unit implemented for example by means of a table as described beforehand may be maintained in other units of the telecommunications network 10, i.e. either in the base station controller 12, 13 or in the base transceiver station 14-17. Depending on which unit of the network 10 maintains the table, said unit, e.g. the base station controller 12, 13 or the base transceiver station 14-17, overwrites (patches) the network identity sent from the mobile switching center 11 according to the contents of the table if needed. If, for example, in a shared network one base station controller 12 is solely operated by one provider that base station controller 12 would overwrite any network identity sent from the mobile switching center 11 with the network identity of that provider.

According to another embodiment of the invention the network 10, e.g. a mobile station controller 11, is provided to send

## 15

all possible network identity strings to another unit of the network, i.e. the base station controller 12, 13 or the base transceiver station 14-17. The addressed unit 12, 13; 14-17 will store all received network identity data in a mapping table associating each network identity with at least one mobile network code (MNC). When processing a location update with a mobile station 18 the unit 12, 13; 14-17 will check the table for the mobile network code MNC and will transfer the associated network identity to the mobile station 18.

The approach as described beforehand may as well be employed to transfer local time data to mobile stations 18, 19. So far there is only a transfer of a single time information for an entire telecommunications network 10. If a telecommunications network 10 extends over more than one time zone this will lead to incorrect time information at mobile stations 18, 19 roaming in a different time zone compared to the time zone where the unit of the network 10 broadcasting the time data, e.g. the mobile switching center 11, is located.

To overcome this deficiency the invention provides a table associating location dependent data 29 with local time data. For example the table may comprise data as follows, where GMT is the abbreviation of Greenwich Mean Time and 1h means one hour:

BSC-1	→	GMT - 1h
BSC-2	→	GMT
BSC-3	→	GMT + 1h
BSC-4	→	GMT + 1h
...	...	

## 16

According to the other embodiments of the invention the table may as well contain location dependent data 29 referring to location areas (LA) or a base station areas (BSA):

LA-1, LA-2, ... LA-100	→	GMT - 1h
LA-101, LA-102, ... LA-200	→	GMT

or

BSA-1, BSA-2, ... BSA-100	→	GMT - 1h
BSA-101, BSA-102, ... BSA-200	→	GMT

In a further preferred embodiment the table may contain local time data as well as network identities 28. A mapping table like this will associate location dependent data 29 to both a respective network identity as well as the respective local time data.

According to still another embodiment of the invention the table 27 comprises no location dependent data 29 but data identifying the mobile station 18, 19 itself. An example for such data identifying the mobile station 18, 19 is the International Mobile Subscriber Identify (IMSI) transferred between the network 10 and the mobile station 18 as shown in FIG 3 when considering the transfer of mobility related data 25. The IMSI is analyzed at least at the mobile switching center 11 to ensure the authorization of the mobile station 18 to attach to the network. Each provider knows the IMSI of their subscribers. Therefore a table similar to the table 27 described beforehand may be set up comprising all the IMSIs of all the subscribers and associating each IMSI with a network identity. When transferring the network identity to the

mobile station 18 of the subscriber the table is searched for the subscriber's IMSI and the respective network identity is transferred to the subscriber. If the number of subscribers exceeds certain thresholds it may be inappropriate to provide a table comprising distinct entries for every IMSI. Instead the table may comprise of data suitable for a logical operation, as for example a logical AND-operation, to associate a set of IMSIs with identical significant elements to a certain network identity. The subsequent list illustrates the contents of such table:

IMSI-1, IMSI-2, ... IMSI-100	→	"Network Identity 1"
IMSI-101, IMSI-102, ... IMSI-200	→	"Network Identity 2"

Although a preferred embodiment of the invention has been illustrated and described herein, it is recognized that changes and variations may be made without departing from the invention as set forth in the claims.

In a further embodiment of the invention, information shall be transported to a mobile station that is not one of Network identity or Timezone information. This enables to send any information to a mobile station.

Figure 4 depicts a flow diagram of a method according to the invention. In a first step 401 of the method, it is started. In a succeeding step 402 it is detected that NITZ information is requested. This detection can be for example by detecting that a NITZ trigger event has occurred, for example by receiving an appropriate message. A NITZ trigger event can be for example the registering of a mobile station on the network, when a mobile station geographically relocates to a

different Local Time Zone, when the network changes its Local Time Zone, e.g. between summer and winter time, when the network changes its identity, or at any time during a signalling connection with mobile station. A NITZ trigger event may also be the detection of the necessity to send information to the mobile station, for example a request to activate or deactivate a functionality, or to indicate that service parameter like price or bandwidth for a service changed.

In a next step 403 a location of the mobile station is determined. This can be performed by means of a location area identity or an identification of a device currently serving the mobile station.

In a further step 404 a NITZ value is determined, preferably depending on the determined location of the mobile station.

In a succeeding step 405 the NITZ information is sent to the mobile station and the method ends in a step 406.

Figure 5 depicts a unit U5 according to the invention. The unit comprises an input unit IU5 for receiving messages, an output unit OU5 for sending messages, a location determining unit LDU5 for determining a location of a mobile station, a calculation unit CU5 for calculating a NITZ value, a control unit CoU5 for co-ordinating and controlling the other units in a way that they implement an invented method and an association unit AU5 for associating information related to a telecommunications service provider to data that is used for determining the NITZ value. Examples for information related to a telecommunications service provider are, an identification of a device used for serving a mobile station, a location area identification, or an identification of a subscription used in the mobile station.

The units may be implemented by means of software, e.g. a software module, by means of hardware or a combination of both. The units are not necessarily located within a single unit or housing, but should be connected to each other for interworking.

## reference signs

10	telecommunications network
11	mobile switching center
12	base stations controller
13	base stations controller
14	base transceiver station
15	base transceiver station
16	base transceiver station
17	base transceiver station
18	mobile station
19	mobile station
20	broadcast
21	local area information
22	mobile country code
23	mobile network code
24	network identity
25	mobility related data
26	visiting location register
27	table
28	network identity / set of network identities
29	location dependent data / location dependent entries

## Claims

1. Method for providing a mobile station (18, 19) engaged with a telecommunications network (10) that comprises a core network (11), a first access network (12, 14, 15) and a second access network (13, 16, 17) with a Network Identity and Timezone information comprising the steps of:
  - detecting that a Network Identity and Timezone information shall be send to a mobile station,
  - determining a location of the mobile station,
  - determining a Network Identity and Timezone information value depending on the location of the mobile station and on an information related to a telecommunications service provider providing a subscription used by the mobile station, and
  - sending the Network Identity and Timezone information towards the mobile station.
2. Method according to claim 1, wherein a core network node (11) maintains a table (27) associating the information related to a telecommunications service provider (29) to data (28) that is used for determining the Network Identity and Timezone value.
3. Method according to claim 1 or 2, wherein the first access network is associated to a first telecommunications service provider and the second access network is associated to a second telecommunications service provider, and wherein the information related to a telecommunications service provider is an identification of a device of an access network that is used to serve the mobile station.
4. Method according to claim 1 or 2, wherein the first access network is associated to a first telecommunications ser-

vice provider and the second access network is associated to a second telecommunications service provider, and wherein the information related to a telecommunications service provider is an identification of a location area.

5. Method according to claim 1 or 2, wherein the information related to a telecommunications service provider is an identification of the subscription.
6. Use of Network and Timezone feature for transmitting information towards a mobile station (18, 19), characterized by replacing information that is usually sent in the Network and Timezone information message by information that shall be transferred to the mobile station.
7. Unit (U5) for a telecommunications network (10) for providing a mobile station (18, 19) engaged with the telecommunications network, with a Network Identity and Timezone information value, wherein the network comprises a core network (11) and at least two access networks (12, 14, 15, 13, 16, 17), and wherein the unit comprises an input unit (IU5), an output unit (OU5), a location determining unit (LDU5), a calculation unit (CU5) for calculating a Network Identity and Timezone information value and a control unit (CoU5),  
characterized by  
an association unit (AU5) for associating information related to a telecommunications service provider to data that is used for determining a Network Identity and Timezone value by the calculation unit.
8. Unit according to claim 7, wherein said information related to a telecommunications service provider is refer-

ring to a least one unit of an access network used for serving the mobile station.

9. Unit according to claim 7, wherein said information related to a telecommunications service provider is a location area identity.
10. Unit according to claim 7, wherein said information related to a telecommunications service provider is an international mobile subscriber identity.

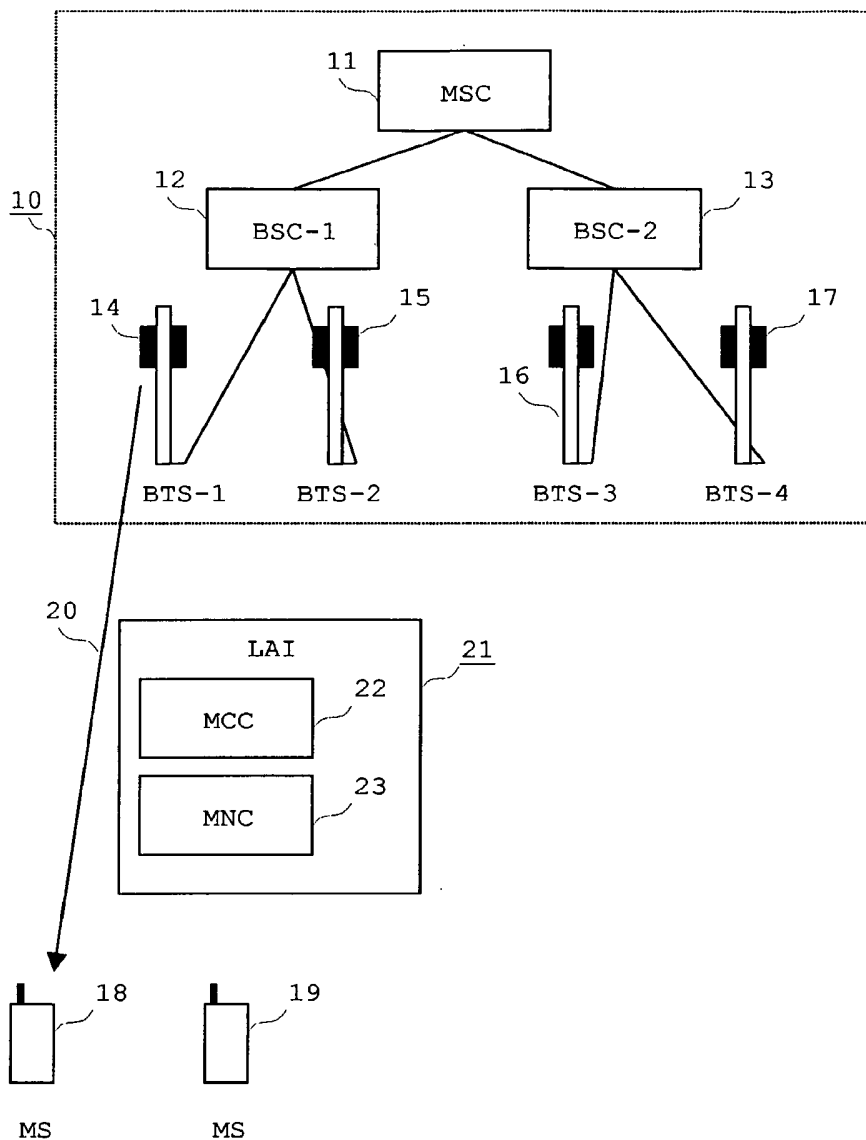

FIG 1

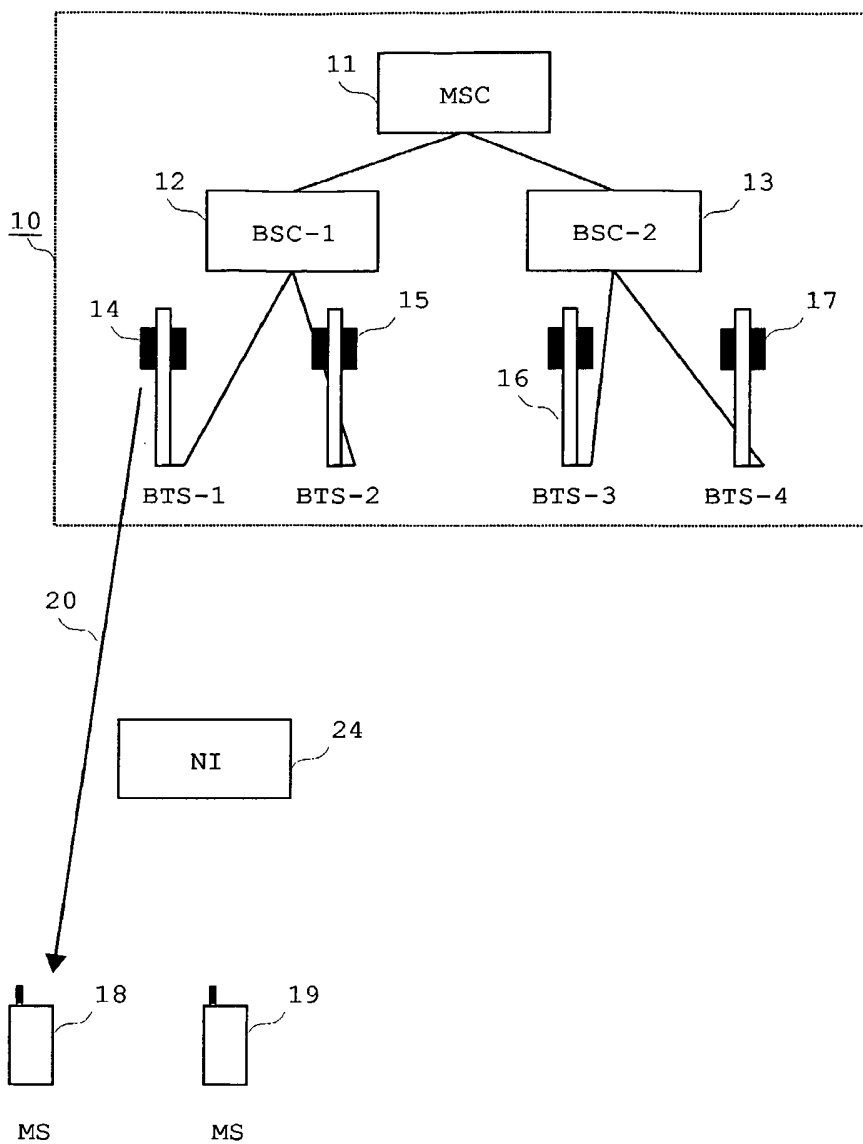

FIG 2

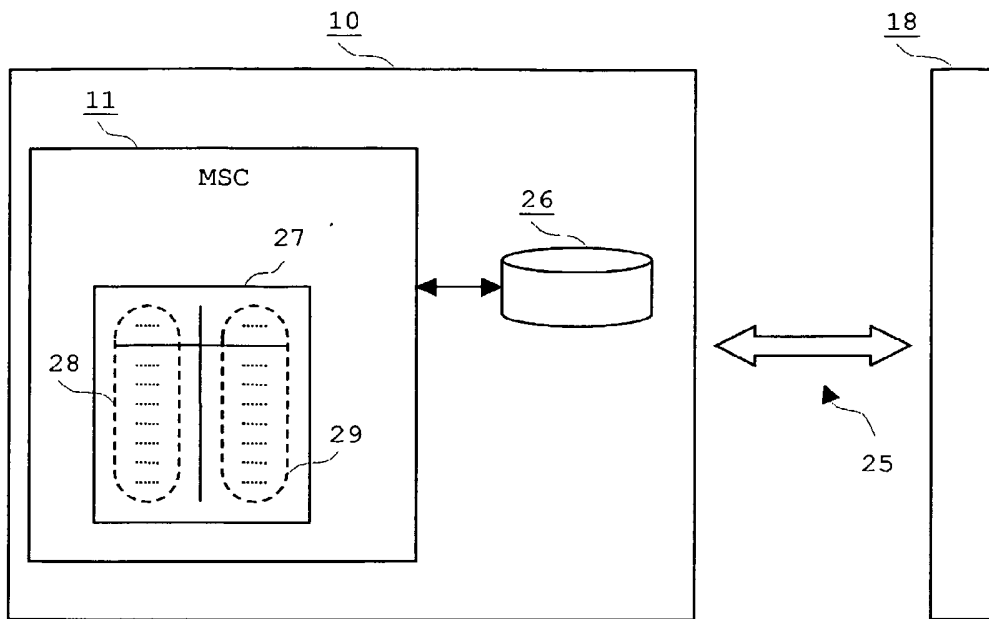

FIG 3

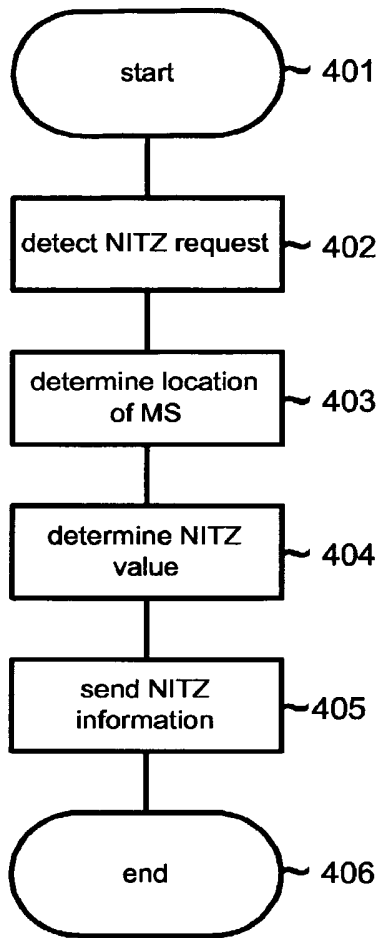

Fig. 4

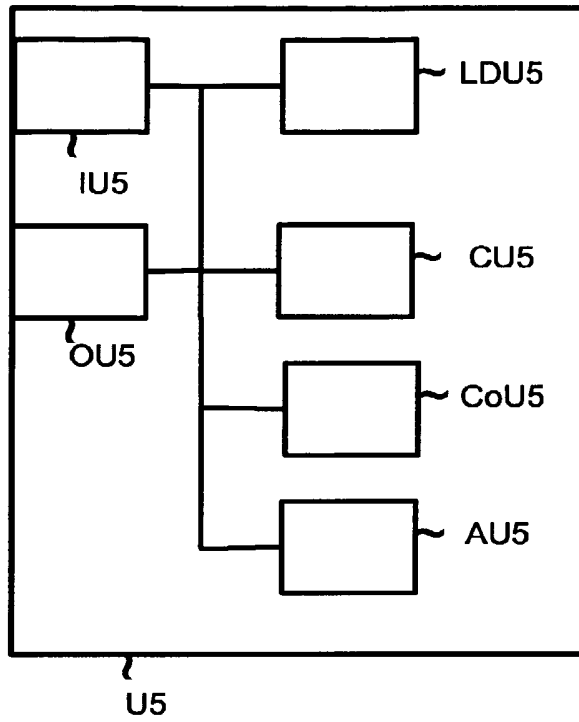

Fig. 5

# INTERNATIONAL SEARCH REPORT

International Application No  
PCT/EP2004/052767

<b>A. CLASSIFICATION OF SUBJECT MATTER</b> IPC 7    H04Q7/38    H04Q7/32				
According to International Patent Classification (IPC) or to both national classification and IPC				
<b>B. FIELDS SEARCHED</b>				
Minimum documentation searched (classification system followed by classification symbols) IPC 7    H04Q    G04G				
Documentation searched other than minimum documentation to the extent that such documents are included in the fields searched				
Electronic data base consulted during the international search (name of data base and, where practical, search terms used)  EPO-Internal				
<b>C. DOCUMENTS CONSIDERED TO BE RELEVANT</b>				
Category °	Citation of document, with indication, where appropriate, of the relevant passages	Relevant to claim No.		
X	"Digital cellular telecommunications system (Phase 2+); Universal Mobile Telecommunications System (UMTS); Network Identity and Time Zone (NITZ) service description; Stage 1 (3GPP TS 22.042 version 5.1.0 Release 5); ETSI TS 122 042" ETSI STANDARDS, EUROPEAN TELECOMMUNICATIONS STANDARDS INSTITUTE, SOPHIA-ANTIPO, FR, vol. 3-SA1, no. V510, June 2003 (2003-06), XP014007147 ISSN: 0000-0001 cited in the application	1,6,7		
A	* sections 1, 4 and 6.1 * ----- -/--	2-5,8-10		
<table style="width: 100%; border: none;"> <tr> <td style="width: 50%; border: none;"> <input checked="" type="checkbox"/> Further documents are listed in the continuation of box C.                 </td> <td style="width: 50%; border: none;"> <input checked="" type="checkbox"/> Patent family members are listed in annex.                 </td> </tr> </table>			<input checked="" type="checkbox"/> Further documents are listed in the continuation of box C.	<input checked="" type="checkbox"/> Patent family members are listed in annex.
<input checked="" type="checkbox"/> Further documents are listed in the continuation of box C.	<input checked="" type="checkbox"/> Patent family members are listed in annex.			
° Special categories of cited documents :				
<table style="width: 100%; border: none;"> <tr> <td style="width: 50%; border: none; vertical-align: top;">                 *A* document defining the general state of the art which is not considered to be of particular relevance                  *E* earlier document but published on or after the international filing date                  *L* document which may throw doubts on priority claim(s) or which is cited to establish the publication date of another citation or other special reason (as specified)                  *O* document referring to an oral disclosure, use, exhibition or other means                  *P* document published prior to the international filing date but later than the priority date claimed             </td> <td style="width: 50%; border: none; vertical-align: top;">                 *T* later document published after the international filing date or priority date and not in conflict with the application but cited to understand the principle or theory underlying the invention                  *X* document of particular relevance; the claimed invention cannot be considered novel or cannot be considered to involve an inventive step when the document is taken alone                  *Y* document of particular relevance; the claimed invention cannot be considered to involve an inventive step when the document is combined with one or more other such documents, such combination being obvious to a person skilled in the art.                  *&amp;* document member of the same patent family             </td> </tr> </table>			*A* document defining the general state of the art which is not considered to be of particular relevance *E* earlier document but published on or after the international filing date *L* document which may throw doubts on priority claim(s) or which is cited to establish the publication date of another citation or other special reason (as specified) *O* document referring to an oral disclosure, use, exhibition or other means *P* document published prior to the international filing date but later than the priority date claimed	*T* later document published after the international filing date or priority date and not in conflict with the application but cited to understand the principle or theory underlying the invention *X* document of particular relevance; the claimed invention cannot be considered novel or cannot be considered to involve an inventive step when the document is taken alone *Y* document of particular relevance; the claimed invention cannot be considered to involve an inventive step when the document is combined with one or more other such documents, such combination being obvious to a person skilled in the art. *&* document member of the same patent family
*A* document defining the general state of the art which is not considered to be of particular relevance *E* earlier document but published on or after the international filing date *L* document which may throw doubts on priority claim(s) or which is cited to establish the publication date of another citation or other special reason (as specified) *O* document referring to an oral disclosure, use, exhibition or other means *P* document published prior to the international filing date but later than the priority date claimed	*T* later document published after the international filing date or priority date and not in conflict with the application but cited to understand the principle or theory underlying the invention *X* document of particular relevance; the claimed invention cannot be considered novel or cannot be considered to involve an inventive step when the document is taken alone *Y* document of particular relevance; the claimed invention cannot be considered to involve an inventive step when the document is combined with one or more other such documents, such combination being obvious to a person skilled in the art. *&* document member of the same patent family			
Date of the actual completion of the international search  <p style="text-align: center; font-size: 1.2em;">27 June 2005</p>		Date of mailing of the international search report  <p style="text-align: center; font-size: 1.2em;">04/07/2005</p>		
Name and mailing address of the ISA European Patent Office, P.B. 5818 Patentlaan 2 NL - 2280 HV Rijswijk Tel. (+31-70) 340-2040, Tx. 31 651 epo nl, Fax: (+31-70) 340-3016		Authorized officer  <p style="text-align: center; font-size: 1.2em;">Goedhart, A</p>		

## INTERNATIONAL SEARCH REPORT

 International Application No  
 PCT/EP2004/052767

C.(Continuation) DOCUMENTS CONSIDERED TO BE RELEVANT		
Category °	Citation of document, with indication, where appropriate, of the relevant passages	Relevant to claim No.
A	US 5 818 920 A (RIGNELL ET AL) 6 October 1998 (1998-10-06) column 6, line 60 - column 7, line 25 figure 3 -----	1-10
A	US 2004/203848 A1 (KUMAR ANIL K) 14 October 2004 (2004-10-14) paragraphs '0008! - '0017! figure 1 -----	1-10
A	GB 2 395 092 A (* VODAFONE GROUP PLC) 12 May 2004 (2004-05-12) page 6, line 23 - page 8, line 4 -----	1-10
A	EP 1 011 276 A (TELEFONAKTIEBOLAGET LM ERICSSON) 21 June 2000 (2000-06-21) paragraphs '0005!, '0006!, '0018! - '0029!, '0050! -----	1-10
A	US 5 790 952 A (SEAZHOLTZ ET AL) 4 August 1998 (1998-08-04) column 8, line 44 - column 8, line 56 column 18, line 5 - column 18, line 49 column 22, line 54 - column 23, line 13 -----	1-10
A	WO 01/15479 A (LUCENT TECHNOLOGIES INC; COSTA, MAURO; PALAT, SUDEEP, KUMAR; ROBERTS,) 1 March 2001 (2001-03-01) page 9, line 10 - page 10, line 20 figures 3,4a,4b -----	1-10

## INTERNATIONAL SEARCH REPORT

 International Application No  
 PCT/EP2004/052767

Patent document cited in search report		Publication date	Patent family member(s)	Publication date
US 5818920	A	06-10-1998	AU 731204 B2	29-03-2001
			AU 5683898 A	29-06-1998
			CN 1245610 A ,C	23-02-2000
			EP 0932973 A1	04-08-1999
			HK 1025701 A1	12-11-2004
			WO 9825395 A1	11-06-1998
-----				
US 2004203848	A1	14-10-2004	NONE	
-----				
GB 2395092	A	12-05-2004	NONE	
-----				
EP 1011276	A	21-06-2000	EP 1011276 A1	21-06-2000
			AU 767772 B2	27-11-2003
			AU 1160300 A	12-07-2000
			CN 1117499 C	06-08-2003
			WO 0038442 A1	29-06-2000
			EP 1142380 A1	10-10-2001
			JP 2002534019 T	08-10-2002
-----				
US 5790952	A	04-08-1998	NONE	
-----				
WO 0115479	A	01-03-2001	AU 5405800 A	19-03-2001
			WO 0115479 A1	01-03-2001
			EP 1205083 A1	15-05-2002
-----				