



(51) International Patent Classification:
F04C 29/04 (2006.01) F01N 3/20 (2006.01)
B01D 53/90 (2006.01)

(74) Agents: JACQUES, Philippe et al.; Solvay Sa, Intellectual Property Department, Rue de Ransbeek, 310, B-1120 Brussels (BE).

(21) International Application Number:
PCT/EP2009/056754

(81) Designated States (unless otherwise indicated, for every kind of national protection available): AE, AG, AL, AM, AO, AT, AU, AZ, BA, BB, BG, BH, BR, BW, BY, BZ, CA, CH, CL, CN, CO, CR, CU, CZ, DE, DK, DM, DO, DZ, EC, EE, EG, ES, FI, GB, GD, GE, GH, GM, GT, HN, HR, HU, ID, IL, IN, IS, JP, KE, KG, KM, KN, KP, KR, KZ, LA, LC, LK, LR, LS, LT, LU, LY, MA, MD, ME, MG, MK, MN, MW, MX, MY, MZ, NA, NG, NI, NO, NZ, OM, PG, PH, PL, PT, RO, RS, RU, SC, SD, SE, SG, SK, SL, SM, ST, SV, SY, TJ, TM, TN, TR, TT, TZ, UA, UG, US, UZ, VC, VN, ZA, ZM, ZW.

(22) International Filing Date:
2 June 2009 (02.06.2009)

(25) Filing Language: English

(26) Publication Language: English

(30) Priority Data:
0853636 3 June 2008 (03.06.2008) FR
0952688 24 April 2009 (24.04.2009) FR

(71) Applicant (for all designated States except US): INERGY AUTOMOTIVE SYSTEMS RESEARCH (SOCIÉTÉ ANONYME) [BE/BE]; Rue de Ransbeek, 310, B-1120 Bruxelles (BE).

(84) Designated States (unless otherwise indicated, for every kind of regional protection available): ARIPO (BW, GH, GM, KE, LS, MW, MZ, NA, SD, SL, SZ, TZ, UG, ZM, ZW), Eurasian (AM, AZ, BY, KG, KZ, MD, RU, TJ, TM), European (AT, BE, BG, CH, CY, CZ, DE, DK, EE, ES, FI, FR, GB, GR, HR, HU, IE, IS, IT, LT, LU, LV, MC, MK, MT, NL, NO, PL, PT, RO, SE, SI, SK, TR), OAPI (BF, BJ, CF, CG, CI, CM, GA, GN, GQ, GW, ML, MR, NE, SN, TD, TG).

(72) Inventors; and

(75) Inventors/Applicants (for US only): GOURIET, Jean-Baptiste [FR/BE]; Av. du cimetière de Bruxelles 139, B-1140 Evere (BE). HABUMUREMYI, Jean-Claude [BE/BE]; Doornstraat 5, B-9450 Haaltert (BE). LEONARD, Stephane [BE/BE]; Av. de l'Arbre Ballon, 110, B-1090 Bruxelles (BE). NAYDENOV, Volodia [BG/BE]; Rue Emile Goes 7/202, B-1348 Louvain-la-neuve (BE).

Published:

— with international search report (Art. 21(3))

[Continued on next page]

(54) Title: PROCESS FOR STARTING AN SCR SYSTEM

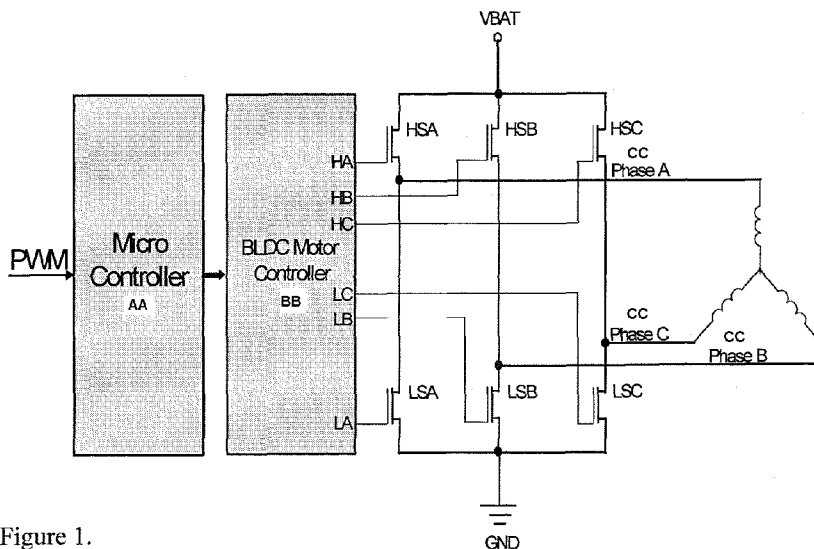

Figure 1.

(57) Abstract: Process for starting an SCR system intended for transporting urea from a tank to the exhaust gases of an engine using a feed line, this system comprising a rotary pump controlled by a controller and driven by a brushless direct current (BLDC) motor that comprises a rotor equipped with at least one permanent magnet and with a stator comprising at least 3 electromagnetic coils in which the direct current can flow according to a given sequence to make the rotor rotate, according to which, before starting the pump, a temperature is measured using a sensor and if this temperature is below a setpoint temperature, before making the rotor rotate, the current is passed through at least one of the coils in a way such that it preheats the pump without making the rotor rotate.

WO 2009/147146 A1



— *before the expiration of the time limit for amending the claims and to be republished in the event of receipt of*

amendments (Rule 48.2(h))

Process for starting an SCR system

The present application relates to a process for starting an SCR system intended to work in freezing conditions. It relates, in particular, to preheating pumps intended for aqueous urea solutions.

5 Legislation on vehicle and heavy goods vehicle emissions stipulates, amongst other things, a reduction in the release of nitrogen oxides NO_x into the atmosphere. One known way to achieve this objective is to use the SCR (Selective Catalytic Reduction) process which enables the reduction of nitrogen oxides by injection of a reducing agent, generally ammonia, into the exhaust line. This ammonia may derive from the pyrolytic decomposition of an ammonia precursor solution, whose concentration may be the eutectic concentration. Such
10 an ammonia precursor is generally a urea solution.

 With the SCR process, the high levels of NO_x produced in the engine during combustion at optimized efficiency are treated in a catalyst on exiting the engine. This treatment requires the use of the reducing agent at a precise
15 concentration and of extreme quality. The solution is thus accurately metered and injected into the exhaust gas stream where it is hydrolysed before converting the nitrogen oxide (NO_x) to nitrogen (N_2) and water (H_2O).

 In order to do this, it is necessary to equip the vehicles with a tank containing an additive solution (generally an aqueous urea solution) and also a
20 device for conveying and metering the desired amount of additive and injecting it into the exhaust line. Given that the aqueous urea solution generally used for this purpose (eutectic 32.5 wt% urea solution) freezes at -11°C , it is necessary to provide a heating device to liquefy the solution in order to be able to inject it into the exhaust line in the event of starting in freezing conditions. This device should
25 ideally cover at least one part of the storage tank and also the line going from this tank to the injector, and preferably also the accessories encountered in this line (filter, pump, etc.).

 In one preferred variant, the subject of Application FR 0755118 in the name of the Applicant, these accessories are integrated into a base plate
30 submerged in the tank and which is heated using a flexible heater, that is to say one or more resistive track(s) inserted between two flexible films or affixed to a flexible film. Although very effective and capable of matching all the shapes of

base plates and of accessories, this type of device has an additional cost and furthermore it does not make it possible to easily heat the inside of large parts such as the pump for example.

5 However, one type of pump that is very efficient, especially for urea systems, is composed of a rotary pump driven by a brushless direct current (BLDC) motor. In such a motor, the rotor is rotated by the sequential switching (according to a defined timing) of electromagnetic coils placed in the stator. Although the conductive wires at the base of these coils (windings) generally have a relatively low resistance (in order to prevent losses via the Joule effect and excessive heating of the motor), they emit however a not inconsiderable
10 heat, which is of course only available once the pump is started.

The present invention is based on the idea of taking advantage of this release of heat via the Joule effect, but without causing the pump to rotate, in order to preheat the pump (before it is started up) in the event of freezing for example.

15 For this purpose, the present application relates to a process for starting an SCR system intended for transporting urea from a tank to the exhaust gases of an engine using a feed line, this system comprising a rotary pump controlled by a controller and driven by a brushless direct current (BLDC) motor that comprises a rotor equipped with at least one permanent magnet and with a stator comprising at
20 least 3 electromagnetic coils in which the direct current can flow according to a given sequence to make the rotor rotate, according to which, before starting the pump, a temperature is measured using a sensor and if this temperature is below a setpoint temperature, before making the rotor rotate, the current is passed
25 through at least one of the coils in a way such that it preheats the pump without making the rotor rotate.

The pump to which the invention applies is a rotary pump driven by a BLDC motor and the operation of which is controlled by a controller. This motor may be an internal or external rotor motor. Preferably, it is an internal rotor motor.

30 The stator of this motor comprises at least 3 coils in order to have at least 3 phases which may be assembled in star or triangle configuration. This stator therefore comprises, in general, a multiple of 3 coils, generally 3, 6 or 9. Good results have been obtained with a motor having an internal rotor and a stator comprising 9 coils positioned uniformly around the rotor, and being connected
35 so as to form 3 phases (i.e. each phase (A, B or C) comprising 3 coils, and said coils being uniformly positioned around the rotor in the order A, B, C, A, B, C,

A, B, C).

The pump to which the process according to the invention applies is preferably designed in order to be able to operate in two opposite rotational directions, one generally corresponding to supplying a feed line with liquid and
5 the other generally corresponding to a purge of the feed line (and of the accessories found therein). In practice, this may be easily achieved by reversing the activation sequence of the coils (phases).

Preferably, the rotary pump is of the gear pump type. These pumps actually have the advantage of providing identical pumping efficiency in both directions
10 of rotation.

Also preferably, the rotor of the pump is an internal rotor provided with at least one recess through which the sucked-up liquid is forced. This variant is the subject of Application FR 0756387 in the name of the Applicant, the content of which is incorporated by reference in the present application. In this variant, the
15 residues of liquids that might be contained in the pump after the purge are optimally heated.

The controller of the pump is a control module (generally comprising a PID (proportional–integral–derivative) regulator and a motor rotational speed controller) and an electric power supply unit which preferably supplies the motor
20 with the power required to rotate it at the desired speed and which enables its direction of rotation to be reversed, where necessary.

Most particularly preferably, an ECM (Electronic Control Module) sends to the pump controller, a CAN (Controller Area Network) message or a PWM (Pulse Width Modulation) control signal having a duty cycle that varies as a
25 function of the desired operating conditions for the pump and the controller then acts on the motor to apply said operating conditions to the pump. Such a system is the subject of Application FR 0700358 in the name of the Applicant, the subject of which is incorporated by reference in the present application.

Within the context of this variant of the invention, the expression
30 "operating conditions" is understood to mean information relating to the operating pressure of the pump (which is zero when this pump is at rest, in preheating mode or not) and also at least one other piece of information such as the stopping/blocking thereof, its rotational direction and the fact that it must operate in preheating mode. They are preferably all the operating conditions of
35 the pump, namely: stopping, forward drive, reverse drive, operating pressure (at the pump outlet), preheating, etc. so that the pump operation is entirely governed

by a single signal. In other words: the controller receives coded instructions (in the form of CAN message or in the form of a PWM signal of variable duty cycle) telling it if it must stop the pump or rotate it forwards, in reverse and at what pressure, or if it must preheat it, which it does by acting on the motor, i.e.

5 generally by in turn sending it a voltage signal which may be of PWM type.

The pump controller interprets this CAN message or PWM-type signal and, depending on the CAN information or on the duty cycle, stops the pump or switches the phases (the coils) in order to regulate the pressure requested or in order to purge the system or in order to heat the pump.

10 In a preferred embodiment, a security is provided in order to prevent the pump from overheating. It is based on the fact that the current decreases with the temperature (since the resistance of the coils increases, while the power supply (voltage) remains constant). In this embodiment, the controller monitors the current and when said current reaches a given minimum value, the power is
15 switched off. In practice, with the 9 coils motor described above, and with a power supply of 0.5 V, this could happen when the current (initially equal to 7 A) reaches 6 A.

The pump to which the process according to the invention applies is intended for pumping (transporting) a liquid in freezing conditions, that is to say
20 when the temperature reaches a low temperature threshold and when the liquid is capable of freezing or solidifying. These may, for example, be aqueous solutions. One liquid to which the present invention applies particularly well is urea.

The term "urea" is understood to mean any, generally aqueous, solution
25 containing urea. The invention gives good results with eutectic water/urea solutions for which there is a quality standard: for example, according to the standard DIN 70070, in the case of the AdBlue[®] solution (commercial solution of urea), the urea content is between 31.8% and 33.2% (by weight) (i.e. 32.5 +/- 0.7 wt%) hence an available amount of ammonia between 18.0% and 18.8%.

30 The invention may also be applied to the urea/ammonium formate mixtures, also in aqueous solution, sold under the trade name Denoxium[™] and of which one of the compositions (Denoxium-30) contains an equivalent amount of ammonia to that of the AdBlue[®] solution. The latter have the advantage of only freezing from -30°C onwards (as opposed to -11°C), but have the disadvantages of
35 corrosion problems linked to the possible release of formic acid and a less available market (whereas urea is widely used and readily available even in

fields such as agriculture). The present invention is particularly advantageous in the context of eutectic water/urea solutions.

The urea is generally contained in a tank onboard a motor vehicle and this tank is advantageously equipped with a base plate or mounting plate (that is to say a support having substantially the shape of a plate) onto which at least one active accessory of the urea storage system and/or injection system is attached. This base plate generally has a perimeter, closed up on itself, of any shape. Usually, its perimeter has a circular shape.

In a most particularly preferred manner, this base plate is a submerged mounting plate, i.e. that seals an opening in the lower wall of the tank, and it integrates at least the pump. The expression "lower wall" is in fact understood to mean the lower half of the tank (whether or not it is moulded in one piece or from two parison sheets or cut-outs).

Within the process according to the invention, in the preheating mode, current is passed through at least one coil (preferably, through all of them) but in a way such that the rotor doesn't rotate. On the contrary, during the operation of the pump, current passes through the coils according to a sequence such that the electromagnetic force or forces generated have a tangential component so as to create a permanent rotational torque. In the case of a motor having 3 coils, it is sufficient, for example, to activate each coil in turn, in a given direction (clockwise or anti-clockwise), while deactivating the other 2, to generate such a torque. In the case of a pump with 9 coils and 3 phases as described above, each phase can be activated in turn for instance.

In order not to generate a permanent torque while getting an heating effect, it is possible, during each heating cycle, to activate the coils (phases) according to a given sequence (time scheme) not generating any torque, or randomly. An example of a given activating sequence generating no torque is given in appended Figures 1 to 3, which will be commented later on.

Alternatively, during each heating cycle, some of the coils (phases) may be powered constantly, while some others are not. This embodiment is preferred because in the former one, at each switch (change of coils which are activated), a punctual torque is generated, which can lead to mechanical tensions if the pump is actually blocked with frozen liquid. In an even more preferred embodiment, the coils which are permanently powered during each heating cycle are memorized by the controller and in the next heating cycle, at least some of them are put at rest while others (at rest in the first heating cycle) are activated. This embodiment has

the advantage of being more simple and of not ageing too much specific coils i.e. of spreading the wear owed to the heating process on all the coils. For example, in the above described pump with 9 coils and 3 phases, the following heating cycles may be repeated (in terms of phases activated continuously during a given cycle):

5 A & B, A & C, B & C. Alternatively, the controller may randomly choose 2 phases to power in each heating cycle.

In a preferred embodiment of the invention, the generation of a punctual torque is avoided also when starting a heating cycle (which happens when starting in freezing conditions and in the case of a pump able to turn in reverse (purge) mode, after the pump has turned in reverse mode the last time the system was running). In order to reach this goal, the stator must be in a magnetic equilibrium position with the rotor before switching of the pump, said equilibrium position corresponding to a zero torque on the rotor when the coils (phases) required for the next heating cycle (programmed in the controller) are activated.

15 This may for instance be done by merely letting the rotor slow down and stop in a given position after a system run (when the power on the pump is switch off), then applying briefly the activation scheme for the next heating cycle so that the magnetic equilibrium position corresponding thereto is reached before definitively switching off the power of the system.

20 Alternatively, the controller may act on the rotor at the end of a system run in order to artificially stop (brake) it (for instance by decreasing its duty cycle gradually so that a zero speed is given as last instruction), memorize the corresponding coils (phases) that were lastly activated in order to activate the same ones continuously in the next heating cycle.

25 The present invention relates, in particular, to a process according to which:

1. the temperature (T1) of the urea held in the tank is determined and compared to the setpoint temperature (T0);
2. if the temperature (T1) is greater than the setpoint temperature (T0), the pump is actuated;
- 30 3. if the temperature (T1) is less than or equal to the setpoint temperature (T0), the tank and the pump are heated, without making the pump rotate, for a duration t1; then
4. the pump is actuated for a duration t2 during which the pump outlet pressure is measured;
- 35 5. if this pressure is stable and in an acceptable margin of the setpoint pressure, the pump is kept going;

6. if this pressure is not stable and/or is not in the acceptable margin of the setpoint pressure, the pump is stopped and the tank and the pump are heated for a duration t_3 , at the end of which steps 4 to 6 are repeated.

One such process, but only with heating of the tank (and not explicitly with heating of the pump, although the latter is heated via the tank heater) is the subject of Application FR 0755875 in the name of the Applicant, the content of which is, for this purpose, incorporated by reference in the present application.

According to one particularly advantageous variant of the process according to the invention, the heating of the pump is not activated all the time the one of the tank is activated since the pump in fact heats up faster than the minimum defrosting time of the tank, so that the danger exists that the pump would overheat. A minimum defrosting time is generally imposed by motor vehicle manufacturers, and is sometimes referred to as the EPA time since the standard for determining this time is imposed in the USA by the EPA (or Environmental Protection Agency), while the Applicant has found that the time required to thaw the pump (with a given design and power supply) is preferably calculated as a function of the temperature (ambient temperature or the temperature in the tank) and of the level of liquid in the tank (which may be determined by a gauge but which is preferably calculated by the ECM).

Therefore, according to one advantageous variant of the process according to the invention, the preheating time ($= T_{pc}$) of the pump via the coils as described above is determined as a function of the temperature and of the volume of liquid in the tank. And according to one particularly advantageous variant, the tank is heated starting from a time t_0 for a duration t_1 and the heating of the pump via its coils is started after a period $t_1 - T_{pc}$, the heating of the tank and that of the pump being stopped at the same time, at the end of a time t_1 therefore, which is generally a fixed duration imposed by the manufacturer (and which is for example the EPA time as described above) whereas T_{pc} is calculated as explained below. In other words: the tank is heated starting from a time t_0 for a duration t_1 and the pump is heated after a period $t_1 - T_{pc}$ for a duration T_{pc} , where t_1 is a fixed duration but where T_{pc} is calculated as a function of the temperature and of the volume of urea present in the tank.

As soon as the heating (of the pump and of the tank) is stopped, i.e. after the period t_1 , the pump is preferably started according to a scheme similar to steps 4 to 6 described above, namely:

1. the pump is actuated for a time t_2 during which the pump outlet pressure is

measured;

2. if this pressure is stable and in an acceptable margin of the setpoint pressure, the pump is kept going;
3. if this pressure is not stable and/or is not in the acceptable margin of the setpoint pressure, the pump is stopped and the tank and the pump are heated for a duration t_3 , at the end of which steps 1 to 3 are repeated.

According to another, even more preferred embodiment of the invention (allowing to better benefit of the heat conduction phenomenon), either the pump is heated at the beginning of the tank heating, or it is heated sporadically in order to reach the total heating time required all over the heating period of the tank.

Alternatively to the embodiments described above, the power supply of the pump (i.e. the current that is passed through the coils of the stator) during preheating can be adapted in order to have the thaw time of the pump match that of the tank.

It should finally be noted that on average the reference voltage is estimated as 13.5 V (volts) for the systems integrated into a vehicle, whereas in practice this voltage may fluctuate. Therefore, according to one advantageous variant of the invention (that can be combined with those described above), the heating time (in particular of the pump) is adapted as a function of the voltage measured by the ECU, notably: if this voltage is below 13.5 V, the heating time will be longer and if it is above 13.5 V, the heating time will be shorter.

In one advantageous variant of the process according to the invention, the feed line is purged after each use of the pump (just before it is stopped) in order to reduce the starting time of the system and avoid prematurely damaging the lines and the accessories (as the urea solutions expand in freezing conditions). The purge may be carried out, for example, by reversing the rotational direction of the pump just for the time necessary to convey the liquid contained in the feed line and the accessories back to the tank.

The present invention also relates to an SCR system for a motor vehicle (car, lorry, etc.) comprising a liquid pump that has a BLDC-type drive motor that comprises a rotor equipped with at least one permanent magnet and a stator comprising at least 3 electromagnetic coils, this motor being controlled by a system that makes it possible to make current flow into at least one of the coils without causing the rotor to rotate.

According to one preferred variant, the SCR system comprises a tank equipped with a heater and a time delay device capable of starting the heating of

the tank and that of the pump at a later time.

It should be noted that the preferred variants described above in the context of the processes apply equally to the pump and to the SCR system according to the invention.

5 The present invention is illustrated non-limitingly by the appended Figures 1 to 4.

10 Figures 1 and 2 illustrate a switching scheme for a BLDC motor having 3 coils that are respectively connected in star configuration (Figure 1) and in triangle configuration (Figure 2). Figure 3 illustrates a logic diagram of switching sequences enabling the preheating of the motor from these Figures 1 and 2. Lastly, Figure 4 illustrates the heating time of the tank and of the pump according to one preferred variant of the invention.

15 The BLDC motor from these figures is intended for a pump controlled by a controller that comprises a control module ("Micro Controller" in the figures) and a power supply for the BLDC motor ("BLDC Motor Controller" in the figures). This controller receives a CAN message or PWM signal from an electronic control module (ECM) that is not illustrated.

The BLDC motor is powered by a voltage source (VBAT) and is earthed (GND).

20 If the BLDC motor is connected in star configuration (Fig.1): firstly, the switches HSA, LSB and LSC are activated. In this case, the current of phase A is the sum of the currents of phases B and C, therefore the coil of phase A will heat up more than the coils of phases B and C. This is why, secondly, in order to equalize the temperature field, the phases are switched by activating the switches
25 HSB, LSA and LSC. In this case it is the current of the phase B which is the sum of the currents of the phases A and C. The third step of the sequence is to activate the switches HSC, LSA and LSB and to obtain a current of the phase C which is the sum of the phases A and B.

30 If the BLDC motor is connected in triangle configuration (Fig.1): firstly, the switches HSA, LSB and LSC are activated. In this case, the current of phase A is the sum of the currents of the coils 1 and 2 which are equal, therefore the coils 1 and 2 heat up in the same way, but there is no current in coil 3 and it does not heat up. Secondly, the phases are switched by activating the switches HSB, LSA and LSC. In this case, it is the current of phase B which is the sum of the currents of
35 the coils 2 and 3, and there is no current in coil 1, which does not heat up. The third step of the sequence is to activate the switches HSC, LSA and LSB and to

obtain a current of the phase C which is the sum of the currents of the coils 1 and 3; there is then no current in coil 2, which does not heat up.

5 A PWM type regulation is applied to the control of the switches in order to vary the current in the phases as explained above (and visualized in the diagram from Figure 3).

By way of example, the current in a BLDC motor that is connected in a triangle configuration is around 6 A when applying a voltage of around 2.5 V, which gives a heating power of around 15 W.

10 Figure 4 illustrates a preferred strategy according to the invention where the pump is heated at a later time relative to the tank, the latter being heated for a predetermined duration t_1 (e.g. the EPA time as described above) whereas the pump is heated for a duration T_{pc} as described previously. Figure 4 in fact illustrates the heating time remaining (t_r) on a timer started at the same time as the heating of the pump, as a function of the time elapsed (t_e) since starting the timer.
15 As can be seen in this figure, the heating of the pump is only started after a period $t_1 - T_{pc}$.

C L A I M S

1. Process for starting an SCR system intended for transporting urea from a tank to the exhaust gases of an engine using a feed line, this system comprising a rotary pump controlled by a controller and driven by a brushless direct current (BLDC) motor that comprises a rotor equipped with at least one permanent magnet and with a stator comprising at least 3 electromagnetic coils in which the direct current can flow according to a given sequence to make the rotor rotate, according to which, before starting the pump, a temperature is measured using a sensor and if this temperature is below a setpoint temperature, before making the rotor rotate, the current is passed through at least one of the coils in a way such that it preheats the pump without making the rotor rotate.
2. Process according to the preceding claim, in which the pump can operate in two opposite rotational directions, one corresponding to supplying a feed line with liquid and the other corresponding to a purge of the feed line (and of accessories found therein, where appropriate).
3. Process according to the preceding claim, in which the pump is a gear pump.
4. Process according to any one of the preceding claims, in which an ECM (Electronic Control Module) sends to the pump controller, a CAN (Controller Area Network) message, or a PWM (Pulse Width Modulation) control signal, having a duty cycle that varies as a function of the desired operating conditions for the pump, these conditions integrating at least one piece of information relating to the operating pressure of the pump and also at least one other piece of information such as the stopping/blocking thereof, its rotational direction and the fact that it must operate in preheating mode.
5. Process according to any one of the preceding claims, in which the controller monitors the current and when said current reaches a given minimum value, the power is switched off.
6. Process according to any one of the preceding claims, according to which during the preheating of the pump, some of the coils are powered constantly and some others are not, the coils which are permanently powered during each preheating cycle being memorized by the controller, and according to which, in the

next preheating cycle, at least some of said coils are deactivated while others (deactivated in the former preheating cycle) are activated..

7. Process according to the preceding claim, according to which the stator is in a magnetic equilibrium position with the rotor before switching of the pump,
5 said equilibrium position corresponding to a zero torque on the rotor when the coils required for the next heating cycle are activated.

8. Process according to any one of the preceding claims, according to which the preheating time (= T_{pc}) of the pump is determined as a function of the temperature and of the volume of liquid in the tank.

9. Process according to any one of the preceding claims, in which the
10 power supply of the pump (i.e. the current that is passed through the coils of the stator) during preheating is adapted in order to have the thaw time of the pump match that of the tank.

10. SCR system for a motor vehicle comprising a liquid pump suitable for
15 a process according to any one of the preceding claims and having a BLDC-type drive motor that comprises a rotor equipped with at least one permanent magnet and a stator comprising at least 3 electromagnetic coils, this motor being controlled by a system that makes it possible to make current flow into at least one of the coils without causing the rotor to rotate.

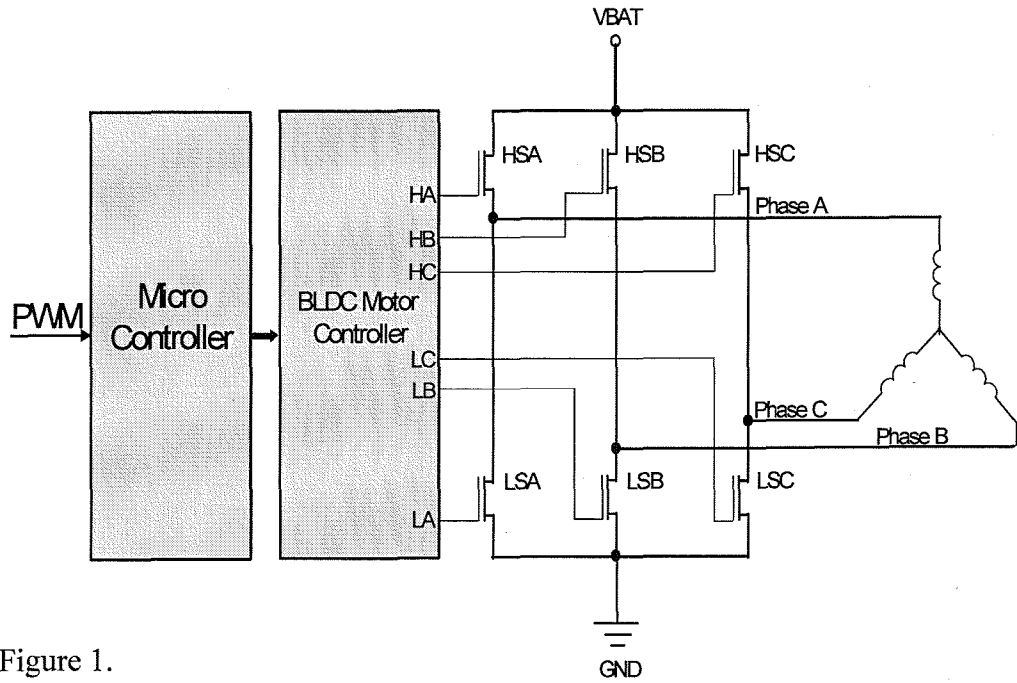

Figure 1.

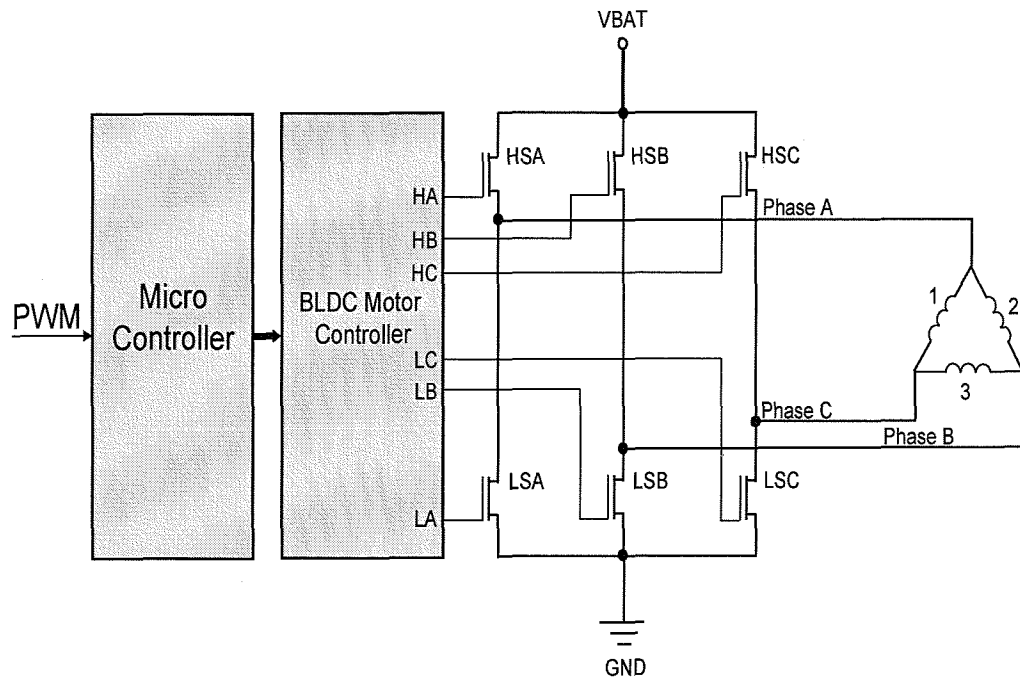

Figure 2

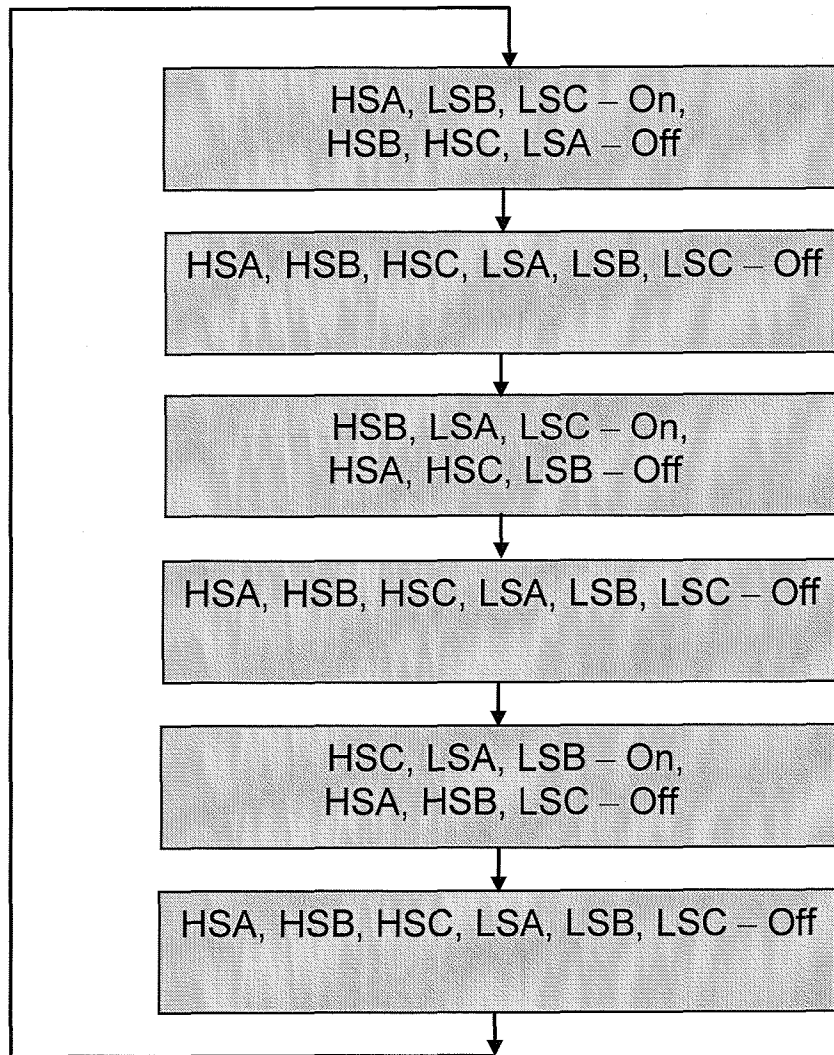

Figure. 3

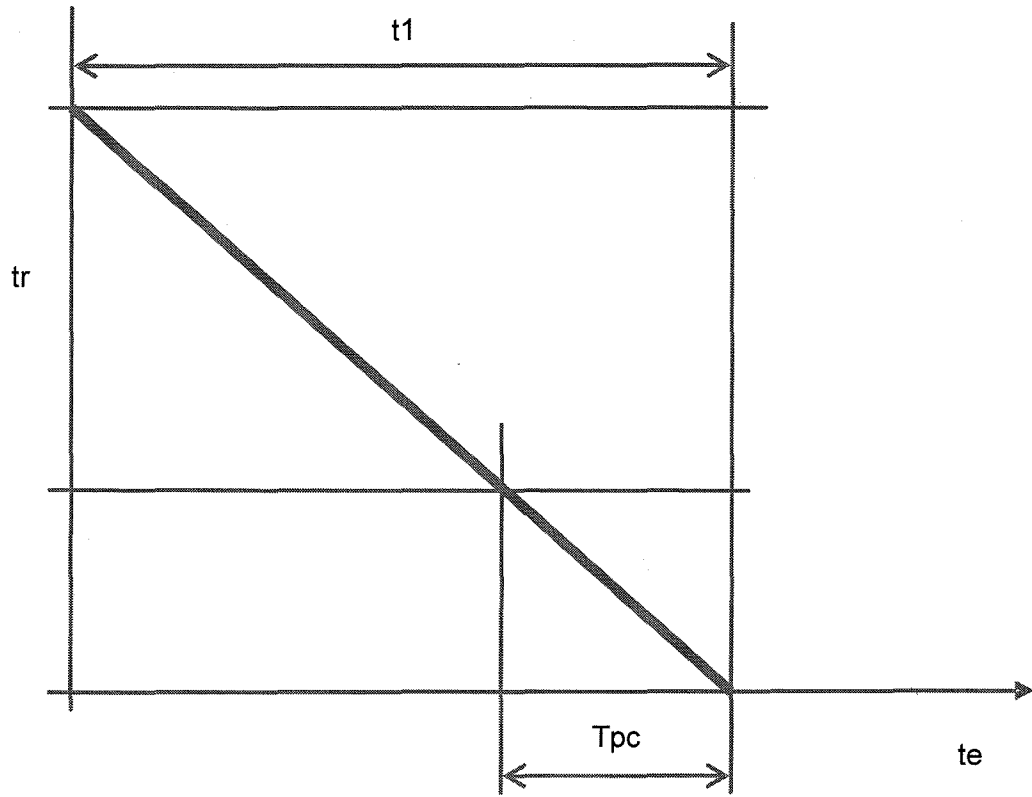

Figure. 4

INTERNATIONAL SEARCH REPORT

International application No

PCT/EP2009/056754

A. CLASSIFICATION OF SUBJECT MATTER
 INV. F04C29/04 B01D53/90 F01N3/20

According to International Patent Classification (IPC) or to both national classification and IPC

B. FIELDS SEARCHED
 Minimum documentation searched (classification system followed by classification symbols)
 F04C B01D F01N

Documentation searched other than minimum documentation to the extent that such documents are included in the fields searched

Electronic data base consulted during the international search (name of data base and, where practical, search terms used)
 EPO-Internal

C. DOCUMENTS CONSIDERED TO BE RELEVANT

Category*	Citation of document, with indication, where appropriate, of the relevant passages	Relevant to claim No.
Y	JP 2006 046151 A (NIDEC SHIBAURA CORP) 16 February 2006 (2006-02-16) abstract; figures 1,2	1-4, 10
Y	WO 2007/141312 A (INERGY AUTOMOTIVE SYSTEMS RES [BE]; DOUGNIER FRANCOIS [BE]; OP DE BEEC) 13 December 2007 (2007-12-13)	1-4, 10
X	page 3, lines 12-16 page 5, lines 7-17 page 9, lines 22,23	10
A	GB 2 273 617 A (TOKYO SHIBAURA ELECTRIC CO [JP]) 22 June 1994 (1994-06-22) pages 7-10	1-4, 10
	----- -/--	

Further documents are listed in the continuation of Box C.

See patent family annex.

* Special categories of cited documents :

- *A* document defining the general state of the art which is not considered to be of particular relevance
- *E* earlier document but published on or after the international filing date
- *L* document which may throw doubts on priority claim(s) or which is cited to establish the publication date of another citation or other special reason (as specified)
- *O* document referring to an oral disclosure, use, exhibition or other means
- *P* document published prior to the international filing date but later than the priority date claimed

- *T* later document published after the international filing date or priority date and not in conflict with the application but cited to understand the principle or theory underlying the invention
- *X* document of particular relevance; the claimed invention cannot be considered novel or cannot be considered to involve an inventive step when the document is taken alone
- *Y* document of particular relevance; the claimed invention cannot be considered to involve an inventive step when the document is combined with one or more other such documents, such combination being obvious to a person skilled in the art.
- *8* document member of the same patent family

Date of the actual completion of the international search 28 October 2009	Date of mailing of the international search report 04/11/2009
---	---

Name and mailing address of the ISA/ European Patent Office, P.B. 5818 Patentlaan 2 NL - 2280 HV Rijswijk Tel. (+31-70) 340-2040, Fax: (+31-70) 340-3016	Authorized officer Biloen, David
--	--

INTERNATIONAL SEARCH REPORT

International application No
PCT/EP2009/056754

C(Continuation). DOCUMENTS CONSIDERED TO BE RELEVANT		
Category*	Citation of document, with indication, where appropriate, of the relevant passages	Relevant to claim No.
A	EP 1 676 628 A (GRUNDFOS MANAGEMENT AS [DK] GRUNDFOS NONOX AS [DK]) 5 July 2006 (2006-07-05) paragraph [0021] -----	1-4, 10
A	WO 00/79108 A (BOSCH GMBH ROBERT [DE]; FRISCH WALTER [DE]; HUBER SVEN [DE]; KRAH JUER) 28 December 2000 (2000-12-28) -----	1-10
A	US 2007/048204 A1 (MITAL RAHUL [US]) 1 March 2007 (2007-03-01) paragraph [0011]; figure 1 -----	1

INTERNATIONAL SEARCH REPORT

Information on patent family members

International application No PCT/EP2009/056754

Patent document cited in search report	A	Publication date	Patent family member(s)	Publication date
JP 2006046151	A	16-02-2006	NONE	
WO 2007141312	A	13-12-2007	EP 2029865 A1 KR 20090026285 A US 2009230136 A1	04-03-2009 12-03-2009 17-09-2009
GB 2273617	A	22-06-1994	JP 6185835 A US 5436547 A	08-07-1994 25-07-1995
EP 1676628	A	05-07-2006	AT 444801 T BR PI0517577 A CN 101090765 A WO 2006072444 A1 JP 2008527228 T KR 20070097464 A RU 2368801 C2 US 2008138221 A1	15-10-2009 14-10-2008 19-12-2007 13-07-2006 24-07-2008 04-10-2007 27-09-2009 12-06-2008
WO 0079108	A	28-12-2000	DE 19946900 A1 EP 1194682 A1 JP 2003502568 T	28-12-2000 10-04-2002 21-01-2003
US 2007048204	A1	01-03-2007	CN 1935335 A DE 102006040361 A1	28-03-2007 29-03-2007