

(19)



(11)

**EP 2 935 760 B1**

(12)

**EUROPEAN PATENT SPECIFICATION**

(45) Date of publication and mention of the grant of the patent:  
**19.06.2019 Bulletin 2019/25**

(51) Int Cl.:  
**E21B 19/24<sup>(2006.01)</sup> E21B 17/02<sup>(2006.01)</sup>**  
**E21B 43/10<sup>(2006.01)</sup>**

(21) Application number: **12890440.6**

(86) International application number:  
**PCT/US2012/071171**

(22) Date of filing: **21.12.2012**

(87) International publication number:  
**WO 2014/098885 (26.06.2014 Gazette 2014/26)**

(54) **IMPROVED LINER HANGER SYSTEM**

VERBESSERTES FUTTER ROHRSTRANGAUFHÄNGERSYSTEM  
SYSTÈME DE SUSPENSION DE COLONNE PERDUE AMÉLIORÉ

(84) Designated Contracting States:  
**AL AT BE BG CH CY CZ DE DK EE ES FI FR GB GR HR HU IE IS IT LI LT LU LV MC MK MT NL NO PL PT RO RS SE SI SK SM TR**

• **MOELLER, Daniel Keith**  
**2241 AX Wassenaar,**  
**Zuid-Holland (NL)**

(43) Date of publication of application:  
**28.10.2015 Bulletin 2015/44**

(74) Representative: **Bennett, Adrian Robert J. et al**  
**A.A. Thornton & Co.**  
**10 Old Bailey**  
**London EC4M 7NG (GB)**

(73) Proprietor: **Halliburton Energy Services Inc.**  
**Houston, Texas 77032 (US)**

(56) References cited:  
**US-A- 4 311 194 US-A1- 2002 079 106**  
**US-A1- 2003 047 320 US-A1- 2003 047 323**  
**US-A1- 2005 263 294 US-A1- 2006 124 295**  
**US-A1- 2009 200 041 US-A1- 2010 089 591**  
**US-A1- 2012 175 846**

(72) Inventors:  
• **ZHONG, Xiaoguang Allan**  
**Plano, TX 75025 (US)**

**EP 2 935 760 B1**

Note: Within nine months of the publication of the mention of the grant of the European patent in the European Patent Bulletin, any person may give notice to the European Patent Office of opposition to that patent, in accordance with the Implementing Regulations. Notice of opposition shall not be deemed to have been filed until the opposition fee has been paid. (Art. 99(1) European Patent Convention).

## Description

### BACKGROUND

**[0001]** The present disclosure relates generally to equipment utilized and operations performed in conjunction with a subterranean well and, more particularly, to an improved liner hanger system.

**[0002]** When performing subterranean operations, a wellbore is typically drilled and completed to facilitate removal of desired materials (e.g., hydrocarbons) from a subterranean formation. Often, once a wellbore is drilled, a casing may be inserted into the wellbore. Cement may then be used to install the casing in the wellbore and prevent migration of fluids in the annulus between the casing and the wellbore wall. In certain implementations, the casing may be made of heavy steel.

**[0003]** Once an upper portion of the wellbore has been drilled and cased, it may be desirable to continue drilling and to line a lower portion of the wellbore with a liner lowered through the upper cased portion thereof. Liner hangers are typically used to mechanically support an upper end of the liner from the lower end of a previously installed casing. Additionally, liner hangers may be used to seal the liner to the casing.

**[0004]** Traditional liner hangers utilized slips for mechanically supporting the liner from the casing and packers to seal the different components. Expandable liner hangers ("ELH(s)") such as VERSAFLEX™, available from Halliburton Energy Services, have been recently developed and provide an improvement over traditional liner hangers. Specifically, ELHs utilize elastomeric rings (e.g., rings made of rubber) carried on a section of expandable tubing to provide both mechanical support and a fluid seal. Accordingly, once an ELH is placed at a desired position downhole within a casing, an expansion cone may be forced through the ELH. The expansion cone expands the elastomeric rings of the ELH, bringing them into contact with the casing to provide both mechanical support and a fluid seal between the casing and a liner.

**[0005]** It is often desirable to use an ELH in a larger size casing (e.g., casing having a diameter of between approximately 0.14 m (5.5") and approximately 0.56 m (22") and/or a high pressure high temperature ("HPHT") environment downhole. However, the properties of elastomeric rings of an ELH are often susceptible to changes in pressure and temperature. Accordingly, the high pressures and high temperatures of HPHT environments can adversely impact the ELH's ability to provide mechanical support and/or seal the liner to the casing. These adverse impacts become even more pronounced in instances when the liner is installed in a large casing.

**[0006]** US 2003/047323 relates to an apparatus and method of creating a seal between two coaxial tubulars so as to create a hanger and a packer. A first tubular is disposed coaxially within a portion of a second, larger tubular. A portion of the first tubular is expanded into fric-

tional contact with the second tubular, thereby creating a liner and a hanger. In one embodiment, a pattern of grooves and profile cuts are formed in the surface of a portion of the first tubular body. The grooves in one aspect define a continuous pattern about the circumference of the tubular body which intersect to form a plurality of substantially identical shapes, such as diamonds. The grooves and profile cuts serve to improve the tensile strength of the tubular body. At the same time, the grooves and profile cuts allow for expansion of the tubular body by use of less radial force. The grooves and profile cuts further provide a gripping means, providing additional frictional support for hanging the expanded tubular onto the inner surface of a surrounding second tubular.

**[0007]** US 2006/124295 relates to methods and apparatus to create an attachment and a seal between two tubular members in a wellbore. An expandable assembly includes a packer and liner hanger to be expanded into a surrounding tubular. The packer can be a longitudinally corrugated packer and can have a sealing element disposed on an outer surface thereof. The liner hanger can include a plurality of formations extending outward along an outer surface of the liner hanger to form interspaces for longitudinal fluid flow between the formations. In operation, an expansion tool moves axially through an inner diameter of the expandable assembly to expand the liner hanger with a fluted expander and subsequently the packer with a substantially uniform outer diameter cone.

**[0008]** US 2003/047320 relates to a liner hanger and a method of hanging a liner in a wellbore. In one aspect, a process for setting a liner in a wellbore is provided in which a tubular having a slip formed on an outer diameter of the tubular at a first location and a preformed bypass for circulating a fluid disposed at a second location is set and expanded into substantial contact with an inner diameter of the wellbore, a casing, or another liner. In another aspect, a process for setting a liner in a wellbore is provided in which a tubular having a slip formed on an outer diameter of the tubular at a first location is placed in the wellbore, a bypass for circulating a fluid is formed downhole, the liner is set and expanded into substantial contact with an inner diameter of the wellbore, a casing, or another liner. In yet another aspect, a process for creating a liner top seal is provided in which the liner is set by expanding a protrusion in an upper end of a tubular into substantial contact with an inner diameter of the wellbore, and the upper end of the tubular is then reformed and expanded into substantial contact with the inner diameter of the wellbore.

### BRIEF DESCRIPTION OF THE DRAWINGS

**[0009]** A more complete understanding of the present embodiments and advantages thereof may be acquired by referring to the following description taken in conjunction with the accompanying drawings, in which like reference numbers indicate like features.

Figure 1 is a cross-sectional view of a liner hanger system in accordance with the prior art.

Figure 2 is a cross-sectional view of a liner hanger system in accordance with an illustrative embodiment of the present disclosure.

Figure 3 is a cross-sectional view of spikes of a liner hanger in accordance with another illustrative embodiment of the present disclosure.

**[0010]** While embodiments of this disclosure have been depicted and described and are defined by reference to exemplary embodiments of the disclosure, such references do not imply a limitation on the disclosure, and no such limitation is to be inferred. The subject matter disclosed is capable of considerable modification, alteration, and equivalents in form and function, as will occur to those skilled in the pertinent art and having the benefit of this disclosure. The depicted and described embodiments of this disclosure are examples only, and not exhaustive of the scope of the disclosure.

#### DETAILED DESCRIPTION

**[0011]** The present disclosure relates generally to equipment utilized and operations performed in conjunction with a subterranean well and, more particularly, to an improved liner hanger system.

**[0012]** Illustrative embodiments of the present disclosure are described in detail below. In the interest of clarity, not all features of an actual implementation are described in this specification. It will of course be appreciated that in the development of any such actual embodiment, numerous implementation-specific decisions must be made to achieve the developers' specific goals, such as compliance with system-related and business-related constraints, which will vary from one implementation to another. Moreover, it will be appreciated that such a development effort might be complex and time-consuming, but would nevertheless be a routine undertaking for those of ordinary skill in the art having the benefit of the present disclosure.

**[0013]** To facilitate a better understanding of the present disclosure, the following examples of certain embodiments are given. In no way should the following examples be read to limit, or define, the scope of the disclosure. Embodiments of the present disclosure may be applicable to horizontal, vertical, deviated, or otherwise nonlinear wellbores in any type of subterranean formation. Embodiments may be applicable to injection wells as well as production wells, including hydrocarbon wells. Devices and methods in accordance with certain embodiments may be used in one or more of wireline, measurement-while-drilling (MWD) and logging-while-drilling (LWD) operations. Certain embodiments according to the present disclosure may provide for a single trip liner setting and drilling assembly.

**[0014]** The terms "couple" or "couples" as used herein are intended to mean either an indirect or a direct con-

nection. Thus, if a first device couples to a second device, that connection may be through a direct connection, or through an indirect electrical or mechanical connection via other devices and connections. The term "wellbore" as used herein refers to any hole drilled into a formation for the purpose of exploration or extraction of natural resources such as, for example, hydrocarbons. The term "uphole" as used herein means along the drillstring or the hole from the distal end towards the surface, and "downhole" as used herein means along the drillstring or the hole from the surface towards the distal end.

**[0015]** It will be understood that the term "oil well drilling equipment" or "oil well drilling system" is not intended to limit the use of the equipment and processes described with those terms to drilling an oil well. The terms also encompass drilling natural gas wells or hydrocarbon wells in general. Further, such wells can be used for production, monitoring, or injection in relation to the recovery of hydrocarbons or other materials from the subsurface. This could also include geothermal wells intended to provide a source of heat energy instead of hydrocarbons. Embodiments may be applicable to injection wells as well as production wells, including hydrocarbon wells.

**[0016]** Figure 1 depicts an ELH in accordance with the prior art. As shown in Figure 1, a wellbore 10 may be drilled through earth formation 12. A casing 14 may then be placed in an upper portion 16 of the well 10 and held in place by cement 18 which is injected between the casing 14 and the upper portion 16 of well 10.

**[0017]** Below casing 14, a lower portion 20 of the wellbore 10 may be drilled through casing 14. The lower portion 20 may have a smaller diameter than the upper portion 16. A length of liner 22 is shown positioned within the lower portion 20. The liner 22 may be used to line or case the lower portion 20 and/or to drill the lower portion 20. If desired, cement may be placed between the liner 22 and lower portion 20 of wellbore 10. The liner 22 may be installed in the wellbore 10 by means of a work string 24. The work string 24 may include a releasable collet, not shown, by which it can support and rotate the liner 22 as it is placed in the wellbore 10.

**[0018]** Attached to the upper end of, or formed as an integral part of, liner 22 is a liner hanger 26 which may include a number of annular seals 28. While three seals 28 are depicted for illustrative purposes, any number of seals 28 may be used. A polished bore receptacle, or tie back receptacle, 30 may be coupled to the upper end of the liner hanger 26. In one embodiment, the polished bore receptacle 30 may be coupled to the liner hanger 26 by a threaded joint 32, but in other embodiments a different coupling mechanism may be employed. The inner bore of the polished bore receptacle 30 may be smooth and machined to close tolerance to permit work strings, production tubing, etc. to be connected to the liner 22 in a fluid-tight and pressure-tight manner. For instance, a work string may be connected by means of the polished bore receptacle 30 and used to pump fracturing fluid at high pressure down to the lower portion 20

of the wellbore 10 without exposing the casing 14 to the fracturing pressure.

**[0019]** It is desirable that the outer diameter of liner 22 be as large as possible while being able to lower the liner 22 through the casing 14. It is also desirable that the outer diameter of the polished bore receptacle 30 and the liner hanger 26 be about the same as the diameter of liner 22. In the run in condition, the outer diameter of liner hanger 26 is defined by the outer diameter of the annular seals 28. In the run in condition, a body or mandrel 34 of liner hanger 26 has an outer diameter reduced by about the thickness of the seals 28 so that the outer diameter of the seals is about the same as the outer diameter of liner 22 and tie back receptacle 30.

**[0020]** In this embodiment, first and second expansion cones 36 and 38 may be carried on the work string 24 just above the reduced diameter body 34 of the liner hanger 26. Fluid pressure applied between the work string 24 and the liner hanger 26 may be used to drive the cones 36, 38 downward through the liner hanger 26 to expand the body 34 to an outer diameter at which the seals 28 are forced into sealing and supporting contact with the casing 14. The first expansion cone 36 may be a solid, or fixed diameter, cone having a fixed outer diameter smaller than the inner diameter 33 of the threaded joint 32. In the run in condition, second expansion cone 38 may have an outer diameter greater than first cone 36 and also greater than the inner diameter 33 of the threaded joint 32. In an embodiment, the second expansion cone 38 may be collapsible, that is, may be reduced in diameter smaller than the inner diameter 33 of the threaded joint 32 when it needs to be withdrawn from the liner hanger 26. In some contexts, the second expansion cone 38 may be referred to as a collapsible expansion cone. After the liner hanger 26 is expanded, expansion cones 36, 38 may be withdrawn from the liner hanger 26, through the polished bore receptacle 30 and out of the wellbore 10 with the work string 24.

**[0021]** Typical seals 28 are made of elastomeric elements (e.g., rubber) which as discussed above may be susceptible to degradation as a result of exposure to the high temperatures and high pressures downhole. In accordance with an embodiment of the present disclosure, the seals 28 may be replaced with one or more metallic spikes. Figure 2 depicts a cross-sectional view of a system, including an improved liner hanger 26' where spikes 202 in accordance with an illustrative embodiment of the present disclosure have replaced the seals 28. The spikes 202 may be metal spikes. The metal spikes may be made of any suitable steel grade, Aluminum, any other ductile material, and a combination thereof. In certain implementations, the spikes may be made from a combination of one or more of the recited materials. In certain embodiments, the spikes 202 may be made from AISI4140 steel or AISI4340 steel. In certain implementations, each spike 202 may be a circular ring that extends along an outer perimeter of the liner hanger 26' at a desired axial location. However, the present disclosure is

not limited to this particular configuration of spikes 202. For instance, in certain embodiments, the spikes 202 may extend along an axial direction of the liner hanger 26'. Moreover, in certain implementations, the different spikes 202 may have different surface geometries without departing from the scope of the present disclosure. Specifically, a first spike may extend along an outer perimeter of the liner hanger 26' at a first axial position along the liner hanger 26' and a second spike may extend along an outer perimeter of the liner hanger 26' at a second axial position along the liner hanger 26'.

**[0022]** The spikes 202 may be formed using any suitable methods known to those of ordinary skill in the art. For instance, in certain implementations, the spikes 202 may be formed by machining the hanger body 26'. However, the present disclosure is not limited to machined spikes. In fact, any suitable methods known to one of ordinary skill in the art may be used to form the spikes 202. For instance, in certain implementations, the spikes 202 may be formed as a separate structure that can be coupled to the liner hanger 26' using any suitable coupling mechanisms known to one of ordinary skill in the art. Moreover, any number of spikes 202 may be formed along the axial direction of the liner hanger 26'. The number of spikes 202 formed along the axial direction of the liner hanger 26' may depend upon a number of factors such as, for example, the anchor load that is desired to be reached.

**[0023]** Accordingly, each of the spikes 202 provide a metal-to-metal seal between the liner hanger 26' and the casing 14. In certain implementations, the spikes 202 may have a flat top portion 204. The use of spikes 202 with a flat top portion 204 as opposed to pointed spikes or threads is beneficial because flat spikes 202 are less sensitive to casing variations and have a higher load capacity than pointed spikes. The spikes 202 may be symmetrically aligned such that an angle  $\theta$  is the same on both sides of each spike 202 as shown in Figure 2. However, in certain implementations, the angle  $\theta$  may be different on the opposing sides of the spike 202 without departing from the scope of the present disclosure. The angle  $\theta$  is referred to herein as the "spike angle." In one embodiment, the spike angle ( $\theta$ ) is selected such that after expansion, the spikes 202 remain substantially normal to the liner hanger 26' body. For instance, in certain implementations, the spike angle ( $\theta$ ) may be selected to be in a range of from approximately 30° to approximately 70°.

**[0024]** Moreover, as shown in Figure 2, the dimension  $\delta$  denotes the width of the flat portion 204 of the spike 202 and is referred to herein as the spike width ( $\delta$ ). The spike width ( $\delta$ ) may be selected as desired such that the liner hanger 26' can expand without significant increase in expansion pressure while maintaining optimum contact area between the spikes 202 and the casing 14. Specifically, as the spikes 202 are expanded, the flat portion 204 of the spike interfaces with the inner surface of the casing 14 and will eventually couple the liner hanger 26'

to the casing 14. The spikes 202 may be extended using one or more expansion cones in a manner similar to that disclosed in conjunction with expanding the seals 28 of Figure 1. As shown in Figure 2, the spacing between the spikes 202 along the length of the liner hanger 26' is denoted as "L". The distance between the spikes (L) may be configured such that the deformation zones in the casing 14 induced by the spikes 202 are isolated. The distance (L) may be selected to maximize the hanging capacity per spike. The term "hanging capacity" as used herein refers to the maximum downward load (anchor load) a hanger can carry without inducing an appreciable relative motion between the hanger 26' and the casing 14 after the hanger is set in the casing. Accordingly, in certain implementations, it may not be desirable for the distance between the spikes (L) to fall below a certain threshold value. For instance, in certain implementations, it may not be desirable for the distance between the spikes (L) to be less than three times the thickness of the casing 14. Accordingly, the distance (L) between the spikes 202 has an optimum value which is dependent upon a number of factors including, but not limited to, the outer diameter of the hanger (hanger OD), the hanger wall thickness, the inner diameter of the casing (casing ID) and the casing wall thickness. Moreover, the available length of the liner hanger 26' may limit the number of spikes 202 that may be placed thereon. Beyond this optimum value an increase in the distance (L) will no longer improve the hanging capacity per spike.

**[0025]** The height (H) of the spikes 202 (and their resulting outer diameter (OD)) may be configured to have dimensions similar to the seals 28. Specifically, in certain implementations, the height (H) of the spike (also referred to herein as "spike height") must be selected so that it is between an upper and a lower boundary. The upper spike height boundary may be selected as a function of the amount of flow area that is desired around the liner hanger 26' and the amount of possible rubber compression between the liner hanger 26' and the casing 14. In contrast, the lower spike height boundary may be selected as a function of the amount of rubber compression desired between the liner hanger 26' and the casing 14. Moreover, if the spike height is too large, it may destroy downhole equipment as it expands and if the spike height is too low, it wouldn't be able to support a liner as required. Configuration of the height (H) may cause a significant deformation of the spikes 202 and an appreciable localized plastic deformation of the casing. Once the spikes 202 of the liner hanger 26' are expanded, the spikes 202 and the inner diameter of the casing 14 form multiple metal-to-metal seals. The liner hanger 26' is coupled to the liner 22. Accordingly, the spikes 202 of the liner hanger 26' provide mechanical support for the liner 22.

**[0026]** Figure 3 depicts a partial cross-sectional view of a liner hanger 26" having spikes 302 in accordance with another implementation of the present disclosure. The spikes 302 may be configured in the same manner discussed above in conjunction with Figure 2. The spikes

302 may be metal spikes. In certain implementations, each spike 302 may be a circular ring that extends along an outer perimeter of the liner hanger 26". The spikes 302 may be formed using any suitable methods known to those of ordinary skill in the art. For instance, in certain implementations, the spikes 302 may be formed by machining the hanger body 26". Moreover, any number of spikes 302 may be formed along the axial direction of the liner hanger 26". The number of spikes 302 formed along the axial direction of the liner hanger 26" may depend upon a number of factors such as, for example, the anchor load that is desired to be reached. Accordingly, each of the spikes 302 may provide a metal-to-metal seal between the liner hanger 26" and the casing 14.

**[0027]** In accordance with this implementation, a sealing element may be positioned at a desired location and utilized in conjunction with the spikes 302. For instance, in certain implementations, a sealing element 304 may be placed at an axial position on the liner hanger 26" above and/or below the spikes 302. The axial section of the liner hanger that contains the spikes 302 may be referred to herein as the "spiked portion." In the illustrative embodiment of Figure 3, a first sealing element 304A and a second sealing element 304B are positioned at distal ends of the spiked portion. The placement of a sealing element at one or both of the distal ends of the spiked portion of the liner hanger 26" may provide redundancy and pressure integrity for the system. This redundancy may be particularly beneficial in instances when one or more of the leading spikes 302 are damaged when the liner hanger 26" is being directed downhole.

**[0028]** The sealing element 304 may be made of any suitable material, including, but not limited to, rubber, extremely ductile metals (e.g., AISI type 316L stainless steel), other polymeric materials, or any other pliable material known to those of ordinary skill in the art. With the liner hanger spikes 302 in an expanded position, the sealing element 304 reinforces the seal between the liner 22 and the casing 14. The implementation of Figure 3 may be particularly beneficial in instances when installed in a large size casing or a galled casing inner diameter having a pronounced inner diameter weld seam.

**[0029]** Although one sealing element 304 is shown in Figure 3, as would be appreciated by those of ordinary skill in the art having the benefit of the present disclosure, two or more sealing elements 304 may be used between the spikes 302 without departing from the scope of the present disclosure. Moreover, the sealing element 304 may be positioned at any desired location along the liner hanger 26". For instance, one sealing element 304 may be positioned at an axial position on the liner hanger 26" uphole relative to the spiked portion and/or one sealing element 304 may be positioned at an axial position on the liner hanger 26" downhole relative to the spiked portion. In certain implementations, the sealing element 304 may be positioned such that there are equal number of spikes 302 provided uphole and downhole relative to the sealing element 304.

**[0030]** The metallic spikes 202, 302 of the improved liner hanger system (26' or 26") are much less susceptible to degradation than the traditional elastomeric seals 28 when exposed to high temperatures and/or pressures downhole. Moreover, the flat portion of the spikes 202, 302 minimizes the sensitivity of the liner hanger (26' or 26") to variations for a given weight casing. Accordingly, the improved liner hanger (26' or 26") provides several advantages. Not only does it provide an improved anchor load carrying capacity, it reduces the costs associated with performing operations using a liner hanger. Specifically, the use of metallic spikes instead of elastomeric seals 28 reduces the need for replacement of elastomeric elements 28 necessitated by performance of subterranean operations in HTHP environments downhole.

**[0031]** Moreover, the improved liner hanger (26' or 26") reduces the possibility of extruding long elastomers beyond the standard retainer spikes during expansion of the ELH. Specifically, as the liner hanger 26" expands, the spikes 302 and the sealing element 304 are also moved until they touch an Inner Diameter "ID" of the casing 14. As the expansion of the liner hanger 26" continues, the sealing element 304 is compressed along an axis of the liner hanger 26" and stretched along the perimeter of the liner hanger 26" due to pressure applied to it by the liner hanger 26", the inner wall of the casing 14 and the spikes 302 located at its two opposing lateral ends. Consequently, as the sealing element 304 is compressed, it will eventually spill over the spikes 302 located at its lateral ends. However, as the spikes 302 are also pushed out by the liner hanger 26", they cut off the spilled portion of the sealing element 304 and the new compressed volume of the sealing element is trapped between the liner hanger 26" and the casing 14.

**[0032]** Moreover, the use of expandable spikes (202, 302) in the liner hanger (26' or 26") is advantageous over using traditional mechanical mechanisms such as, for example, a gauge hanger. Specifically, in certain implementations, the expandable spikes provide a simple, single-part mechanism that forms a reliable and robust seal between the casing and the liner and supports the liner. Moreover, the use of spikes (202, 302) provides a robust seal in applications where the inner diameter of the casing 14 is imperfect.

**[0033]** Accordingly, once a wellbore is drilled in a subterranean operation, it may be cased using methods and systems known to those of ordinary skill in the art. For instance, a casing may be lowered into the wellbore and cemented in place. A liner coupled to a liner hanger in accordance with an implementation of the present disclosure may then be lowered downhole through a casing. Once the liner reaches a desired position downhole, the metal spikes extending along the perimeter of the liner hanger expand. Once the metal hangers are expanded, the flat portion of the spikes forms a metal-to-metal seal with an inner surface of the casing. This metal-to-metal seal couples the liner to the casing.

**[0034]** Although the figures depict embodiments of the

present disclosure in a particular orientation, it should be understood by those skilled in the art that embodiments of the present disclosure are well suited for use in a variety of orientations. Further, it should be understood by those skilled in the art that the use of directional terms such as above, below, upper, lower, upward, downward and the like are used in relation to the illustrative embodiments as they are depicted in the figures, the upward direction being toward the top of the corresponding figure and the downward direction being toward the bottom of the corresponding figure.

**[0035]** Therefore, the present disclosure is well adapted to attain the ends and advantages mentioned as well as those that are inherent therein. The particular embodiments disclosed above are illustrative only, as the present disclosure may be modified and practiced in different but equivalent manners apparent to those skilled in the art having the benefit of the teachings herein. Furthermore, no limitations are intended to the details of construction or design herein shown, other than as described in the claims below. Also, the terms in the claims have their plain, ordinary meaning unless otherwise explicitly and clearly defined by the patentee. The indefinite articles "a" or "an," as used in the claims, are defined herein to mean one or more than one of the element that the particular article introduces; and subsequent use of the definite article "the" is not intended to negate that meaning.

## Claims

1. A system for performing subterranean operations comprising:

a liner hanger (26') positioned within a casing (14),

wherein the liner hanger comprises a spiked portion having one or more metallic spikes (202), each of the one or more metallic spikes extending in a circular ring along an outer perimeter of the liner hanger (26'); wherein the one or more metallic spikes (202) are tapered to a flat portion (204), wherein at least one of the one or more metallic spikes (202) is expandable, and wherein the flat portion (204) of each of the one or more metallic spikes deforms the casing (14) when the spike is in the expanded position,

wherein each of the one or more metallic spikes (202) provides a metal-to-metal seal between the liner hanger (26') and the casing (14) when the spike (202) is in the expanded position; and a liner (22) coupled to the liner hanger (26').

2. A system as claimed in claim 1, wherein the one or more spikes (202)

(i) are made from a material selected from a group consisting of Aluminum, steel, and a combination thereof; or  
 (ii) comprise a first spike positioned at a first axial location along the liner hanger and a second spike positioned at a second axial location along the liner hanger.

3. A system as claimed in claim 1, wherein expanding the one or more spikes (202) couples the liner hanger (26') to the casing (14).

4. A system as claimed in claim 1, wherein a spike angle of one or more metallic spikes is selected such that the spike is substantially normal to the liner hanger when the spike is in the expanded position.

5. A system as claimed in claim 1, further comprising a sealing element (304), wherein the sealing element is positioned at a distal end of the spiked portion, preferably wherein the sealing element is selected from a group consisting of rubber, polymeric materials and ductile metals.

6. A system as claimed in claim 1, wherein the one or more metallic spikes (202) have an angle  $\Theta$  between a side of the spike and a line normal to the liner hanger, and wherein the angle  $\Theta$  is selected to be in range of from 30° to 70°.

7. A method for coupling a liner (22) to a casing (14) of a cased wellbore in a subterranean formation comprising:

coupling a liner hanger (26') to the liner (22), wherein the liner hanger (26') comprises a spiked portion having a first metal spike (202) comprising a flat portion (204); lowering the liner (22) and the liner hanger (26') downhole through the casing (14); and expanding the first spike (202), wherein the first metal spike causes deformation of the casing (14) and provides a metal-to-metal seal between the liner hanger (26') and the casing (14) when the first metal spike is in the expanded position, and wherein expanding the first spike couples the liner hanger (26') to the casing (14).

8. A method as claimed in claim 7, wherein a spike angle of one or more metallic spikes is selected such that the spike is substantially normal to the liner hanger when the spike is in the expanded position.

9. A method as claimed in claim 7, further comprising

a sealing element (304), wherein the sealing element is positioned at a distal end of the spiked portion.

10. A method as claimed in claim 7, wherein the spiked portion further comprises a second metal spike extending in a circular ring along an outer perimeter of the liner hanger, wherein the first metal spike is positioned at a first axial location along the liner hanger (26') and the second metal spike is positioned at a second axial location along the liner hanger.

11. A method as claimed in claim 7, wherein the first metal spike is either (i) formed by machining, or (ii) made from a material selected from a group consisting of Aluminum, steel, and a combination thereof.

12. A method as claimed in claim 7, wherein the one or more metallic spikes (202) are tapered to a flat portion (204).

20

### Patentansprüche

1. System zum Durchführen von unterirdischen Vorgängen, umfassend:

ein Futterrohrstrangaufhängesystem (26'), das innerhalb eines Futterrohrs (14) angeordnet ist, wobei das Futterrohrstrangaufhängesystem einen mit Zacken versehenen Abschnitt umfasst, der eine oder mehrere Metallzacke(n) (202) aufweist, wobei jede aus der einen oder den mehreren Metallzacke (n) in einem kreisförmigen Ring entlang eines äußeren Umfangs des Futterrohrstrangaufhängesystems (26') verläuft; wobei die eine oder die mehreren Metallzacke(n) (202) sich zu einem flachen Abschnitt (204) verjüngt/verjüngen, wobei mindestens eine aus der einen oder den mehreren Metallzacke(n) (202) ausfahrbar ist, und wobei der flache Abschnitt (204) jeder aus der einen oder den mehreren Metallzacke(n) das Futterrohr (14) verformt, wenn sich die Zacke in der ausgefahrenen Position befindet, wobei jede aus der einen oder den mehreren Metallzacke(n) (202) eine Metall-Metall-Dichtung zwischen dem Futterrohrstrangaufhängesystem (26') und dem Futterrohr (14) bereitstellt, wenn sich die Zacke (202) in der ausgefahrenen Position befindet; und einen Futterrohrstrang (22), der mit dem Futterrohrstrangaufhängesystem (26') verbunden ist.

2. System nach Anspruch 1, wobei die eine oder die mehreren Zacke(n) (202)

(i) aus einem Material hergestellt ist/sind, das

- aus der Gruppe ausgewählt ist, die aus Aluminium, Stahl und einer Kombination daraus besteht; oder
- (ii) eine erste Zacke, die an einer ersten axialen Stelle entlang des Futterrohrstrangaufhängesystems angeordnet ist, und eine zweite Zacke umfasst/umfassen, die an einer zweiten axialen Stelle entlang des Futterrohrstrangaufhängesystems angeordnet ist.
3. System nach Anspruch 1, wobei das Ausfahren der einen oder der mehreren Zacke(n) (202) das Futterrohrstrangaufhängesystem (26') mit dem Futterrohr (14) verbindet.
4. System nach Anspruch 1, wobei ein Zackenwinkel der einen oder der mehreren Metallzacke(n) so ausgewählt ist, dass die Zacke im Wesentlichen senkrecht zum Futterrohrstrangaufhängesystem steht, wenn die Zacke sich in der ausgefahrenen Position befindet.
5. System nach Anspruch 1, ferner umfassend ein Dichtelement (304), wobei das Dichtelement an einem distalen Ende des mit Zacken versehenen Abschnitts angeordnet ist, wobei vorzugsweise das Dichtelement aus einer Gruppe ausgewählt ist, die aus Gummi, polymeren Materialien und dehnbaren Metallen besteht.
6. System nach Anspruch 1, wobei die eine oder die mehreren Metallzacke(n) (202) einen Winkel  $\theta$  zwischen einer Seite der Zacke und einer Linie senkrecht zum Futterrohrstrangaufhängesystem aufweist/aufweisen und wobei der Winkel  $\theta$  im Bereich von  $30^\circ$  bis  $70^\circ$  ausgewählt wird.
7. Verfahren zum Verbinden eines Futterrohrstrangs (22) mit einem Futterrohr (14) eines gefütterten Bohrlochs in einer unterirdischen Formation, umfassend:
- Verbinden eines Futterrohrstrangaufhängesystems (26') mit dem Futterrohrstrang (22), wobei das Futterrohrstrangaufhängesystem (26') einen mit Zacken versehenen Abschnitt umfasst, der eine erste Metallzacke (202) aufweist, die einen flachen Abschnitt (204) umfasst; Absenken des Futterrohrstrangs (22) und des Futterrohrstrangaufhängesystems (26') durch das Futterrohr (14) im Loch nach unten; und Ausfahren der ersten Zacke (202), wobei die erste Metallzacke eine Verformung des Futterrohrs (14) bewirkt und eine Metall-Metall-Dichtung zwischen dem Futterrohrstrangaufhängesystem (26') und dem Futterrohr (14) bereitstellt, wenn sich die erste Metallzacke in der ausgefahrenen Position befindet, und
- wobei das Ausfahren der ersten Zacke das Futterrohrstrangaufhängesystem (26') mit dem Futterrohr (14) verbindet.
8. Verfahren nach Anspruch 7, wobei ein Zackenwinkel der einen oder der mehreren Metallzacke(n) so ausgewählt ist, dass die Zacke im Wesentlichen senkrecht zum Futterrohrstrangaufhängesystem steht, wenn sich die Zacke in der ausgefahrenen Position befindet.
9. Verfahren nach Anspruch 7, ferner umfassend ein Dichtelement (304), wobei das Dichtelement an einem distalen Ende des mit Zacken versehenen Abschnitts angeordnet ist.
10. Verfahren nach Anspruch 7, wobei der mit Zacken versehene Abschnitt ferner eine zweite Metallzacke umfasst, die in einem kreisförmigen Ring entlang eines äußeren Umfangs des Futterrohrstrangaufhängesystems verläuft, wobei die erste Metallzacke an einer ersten axialen Stelle entlang des Futterrohrstrangaufhängesystems (26') angeordnet ist und die zweite Metallzacke an einer zweiten axialen Stelle entlang des Futterrohrstrangaufhängesystems angeordnet ist.
11. Verfahren nach Anspruch 7, wobei die erste Metallzacke entweder (i) durch zerspannende Bearbeitung hergestellt ist, oder (ii) aus einem Material hergestellt ist, das aus einer Gruppe ausgewählt ist, die aus Aluminium, Stahl oder einer Kombination daraus besteht.
12. Verfahren nach Anspruch 7, wobei sich die eine oder die mehreren Metallzacke(n) (202) zu einem flachen Abschnitt (204) verjüngen.
- Revendications**
1. Système pour effectuer des opérations souterraines comprenant :
- une suspension de colonne perdue (26') positionnée à l'intérieur d'un logement (14), dans lequel la suspension de colonne perdue comprend une partie à pointes ayant une ou plusieurs pointes métalliques (202), chacune des une ou plusieurs pointes métalliques s'étendant dans un anneau circulaire le long d'un périmètre externe de la suspension de colonne perdue (26') ; dans lequel les une ou plusieurs pointes métalliques (202) sont effilées en une partie plate (204), dans lequel au moins l'une des une ou plusieurs pointes métalliques (202) est extensible, et dans lequel la partie plate (204) de chacune des

- une ou plusieurs pointes métalliques déforme le logement (14) lorsque la pointe est dans la position déployée,  
 dans lequel chacune des une ou plusieurs pointes métalliques (202) fournit un joint métal sur métal entre la suspension de colonne perdue (26') et le logement (14) lorsque la pointe (202) est dans la position déployée ; et  
 une colonne perdue (22) couplée à la suspension de colonne perdue (26') .
- 5
- 10
2. Système selon la revendication 1, dans lequel les une ou plusieurs pointes (202)
- (i) sont fabriquées à partir d'un matériau choisi dans un groupe constitué d'aluminium, d'acier et d'une combinaison de ceux-ci ; ou
- (ii) comprennent une première pointe positionnée au niveau d'un premier emplacement axial le long de la suspension de colonne perdue et une seconde pointe positionnée au niveau d'un second emplacement axial le long de la suspension de colonne perdue.
- 15
- 20
3. Système selon la revendication 1, dans lequel le déploiement des une ou plusieurs pointes (202) couple la suspension de colonne perdue (26') au logement (14).
- 25
4. Système selon la revendication 1, dans lequel un angle de pointe d'une ou de plusieurs pointes métalliques est choisi de sorte que la pointe est sensiblement perpendiculaire à la suspension de colonne perdue lorsque la pointe est dans la position déployée.
- 30
- 35
5. Système selon la revendication 1, comprenant en outre un élément d'étanchéité (304), dans lequel l'élément d'étanchéité est positionné au niveau d'une extrémité distale de la partie à pointes, de préférence dans lequel l'élément d'étanchéité est choisi dans un groupe constitué de caoutchouc, de matériaux polymères et de métaux ductiles.
- 40
6. Système selon la revendication 1, dans lequel les une ou plusieurs pointes métalliques (202) ont un angle  $\theta$  entre un côté de la pointe et une ligne perpendiculaire à la suspension de colonne perdue, et dans lequel l'angle  $\theta$  est choisi pour se situer dans une plage de 30° à 70°.
- 45
- 50
7. Procédé pour coupler une colonne perdue (22) à un logement (14) d'un puits de forage tubé dans une formation souterraine comprenant :
- 55
- le couplage d'une suspension de colonne perdue (26') à la colonne perdue (22), dans lequel la suspension de colonne perdue (26') comprend une partie à pointes ayant une première pointe métallique (202) comprenant une partie plate (204) ;  
 l'abaissement de la colonne perdue (22) et de la suspension de colonne perdue (26') en fond de puits à travers le logement (14) ; et  
 le déploiement de la première pointe (202), dans lequel la première pointe métallique entraîne une déformation du logement (14) et fournit un joint métal sur métal entre la suspension de colonne perdue (26') et le logement (14) lorsque la première pointe métallique est dans la position déployée, et  
 dans lequel le déploiement de la première pointe couple la suspension de colonne perdue (26') au logement (14).
8. Procédé selon la revendication 7, dans lequel un angle de pointe d'une ou de plusieurs pointes métalliques est choisi de sorte que la pointe est sensiblement perpendiculaire à la suspension de colonne perdue lorsque la pointe est dans la position déployée.
9. Procédé selon la revendication 7, comprenant en outre un élément d'étanchéité (304), dans lequel l'élément d'étanchéité est positionné au niveau d'une extrémité distale de la partie à pointes.
10. Procédé selon la revendication 7, dans lequel la partie à pointes comprend en outre une seconde pointe métallique s'étendant dans un anneau circulaire le long d'un périmètre externe de la suspension de colonne perdue, dans lequel la première pointe métallique est positionnée au niveau d'un premier emplacement axial le long de la suspension de colonne perdue (26') et la seconde pointe métallique est positionnée au niveau d'un second emplacement axial le long de la suspension de colonne perdue.
11. Procédé selon la revendication 7, dans lequel la première pointe métallique est soit (i) formée par usinage, soit (ii) fabriquée à partir d'un matériau choisi dans un groupe constitué d'aluminium, d'acier et d'une combinaison de ceux-ci.
12. Procédé selon la revendication 7, dans lequel les une ou plusieurs pointes métalliques (202) sont effilées en une partie plate (204).

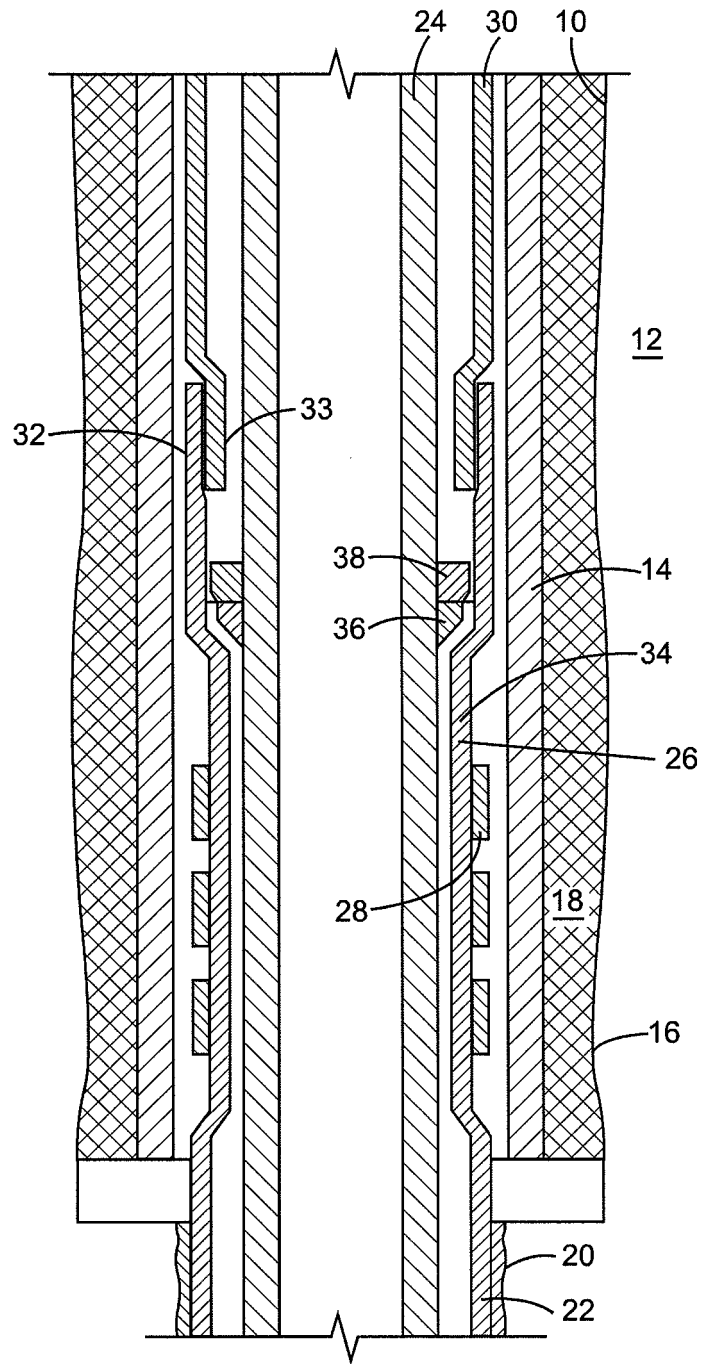

(Prior Art)

Fig. 1

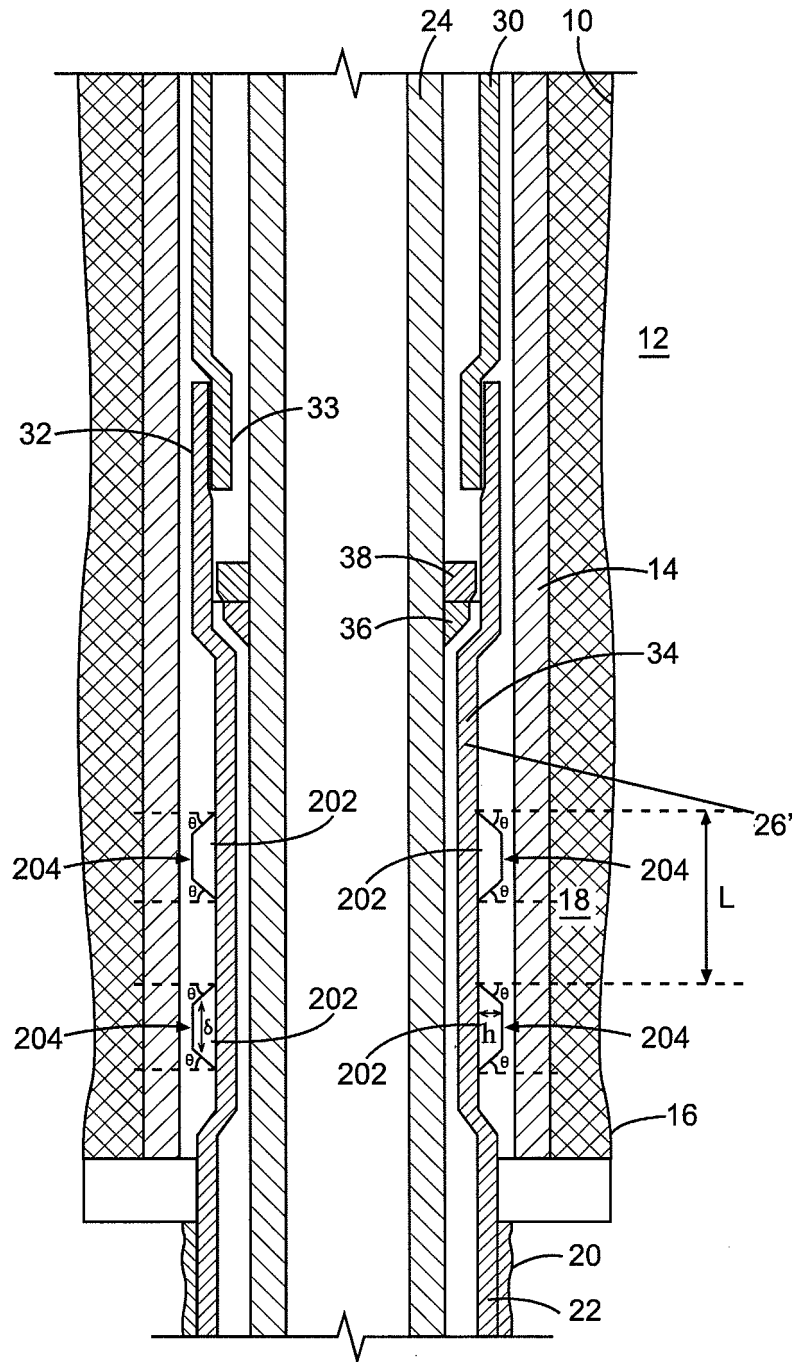

Fig. 2

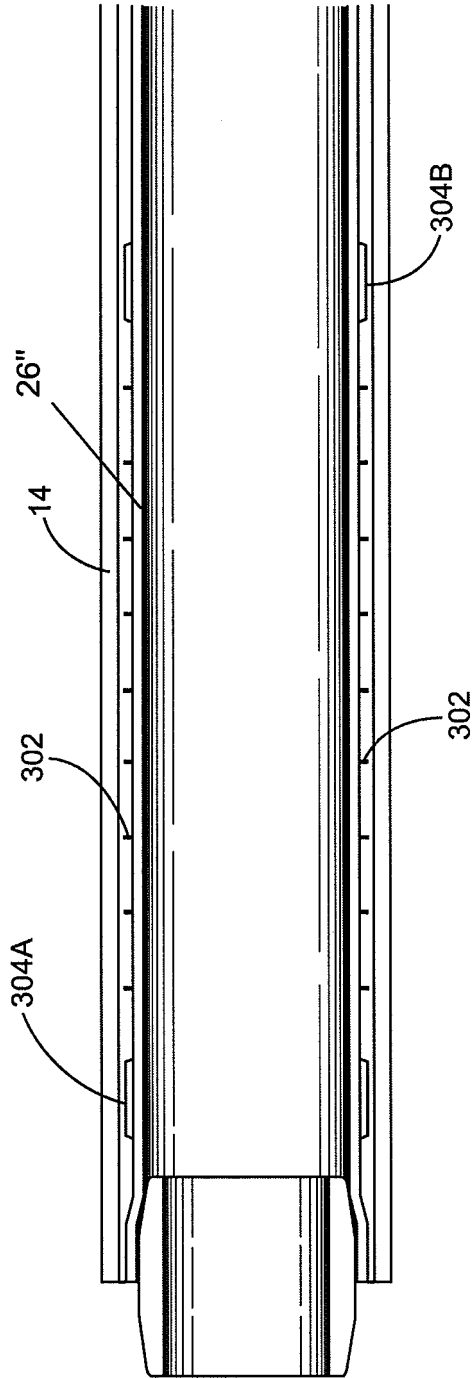

Fig. 3

**REFERENCES CITED IN THE DESCRIPTION**

*This list of references cited by the applicant is for the reader's convenience only. It does not form part of the European patent document. Even though great care has been taken in compiling the references, errors or omissions cannot be excluded and the EPO disclaims all liability in this regard.*

**Patent documents cited in the description**

- US 2003047323 A [0006]
- US 2006124295 A [0007]
- US 2003047320 A [0008]