

(19)



(11)

**EP 4 227 039 A2**

(12)

**EUROPEAN PATENT APPLICATION**

(43) Date of publication:  
**16.08.2023 Bulletin 2023/33**

(51) International Patent Classification (IPC):  
**B24B 7/18** (2006.01)      **B24B 7/22** (2006.01)  
**B24B 55/04** (2006.01)      **B28D 1/18** (2006.01)  
**B24B 55/05** (2006.01)

(21) Application number: **22212447.1**

(22) Date of filing: **09.12.2022**

(52) Cooperative Patent Classification (CPC):  
**B24B 7/186; B24B 7/22; B24B 55/052**

(84) Designated Contracting States:  
**AL AT BE BG CH CY CZ DE DK EE ES FI FR GB GR HR HU IE IS IT LI LT LU LV MC ME MK MT NL NO PL PT RO RS SE SI SK SM TR**  
Designated Extension States:  
**BA**  
Designated Validation States:  
**KH MA MD TN**

(72) Inventors:  
• **WU, Jingchao Hangzhou (CN)**  
• **WU, Bo Hangzhou (CN)**  
• **CAO, Jian Hangzhou (CN)**  
• **XU, Luwen Hangzhou (CN)**

(30) Priority: **19.01.2022 CN 202210062697**

(74) Representative: **Sach, Greg Robert Valet Patent Services LLP Siedlungsstrasse 4a 85253 Erdweg (DE)**

(71) Applicant: **Hangzhou Kinty Tool Manufacture Co., Ltd Hangzhou, Zhejiang 311400 (CN)**

**(54) CONCRETE GRINDER AND CONCRETE GRINDING APPARATUS**

(57) The invention relates to the technical field of concrete grinding equipment, in particular to a concrete grinder and a concrete grinding apparatus. The concrete grinder comprises a main body, wherein the lower end of the main body is rotatably connected with a grinding disk, the outer wall of the main body is rotatably connected with a drive ring, a dust-proof cover is coaxially mounted at the lower end of the drive ring, a plurality of drive grooves are formed on the inner wall of the drive ring, and the drive ring is equipped with an adjusting assembly for locking the position of the drive ring; and the concrete grinding apparatus comprises a main body and a bracket connected thereto, wherein the bottom of the bracket is equipped with at least two sliding wheels, a mounting frame is mounted on the bracket, limiting member are mounted on the mounting frame, an lifting plate is mounted on the main body, limiting grooves are formed on the lifting plate, the limiting members are inserted in the limiting grooves in a sliding manner, and the mounting frame is connected with a locking bolt in a threaded manner. The axial direction of the locking bolt is perpendicular to the extending direction of the limiting grooves. The invention can improve the precision of the concrete grinder.

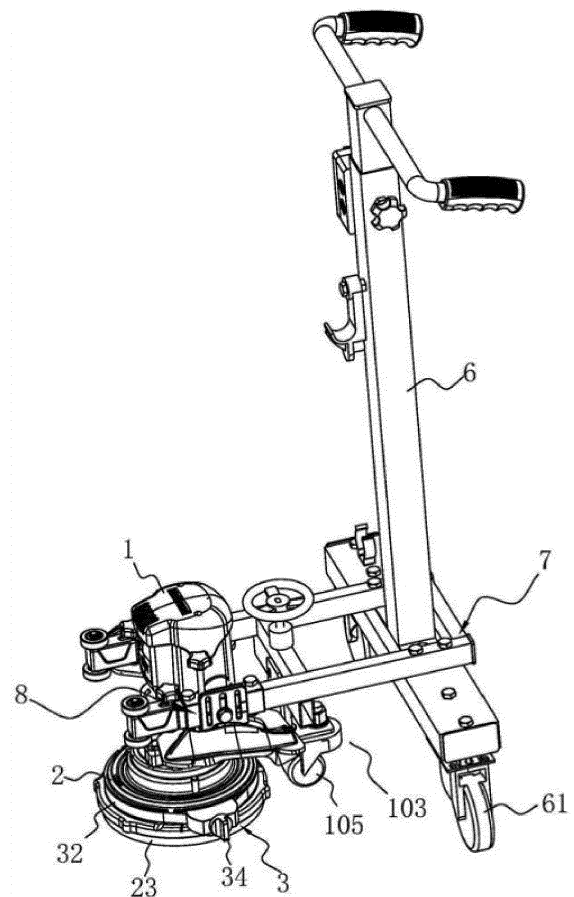

**FIG.1**

**EP 4 227 039 A2**

## Description

### TECHNICAL FIELD

[0001] The invention relates to the technical field of concrete grinding equipment, in particular to a concrete grinder and a concrete grinding apparatus.

### BACKGROUND ART

[0002] A concrete grinder is a common specialized tool in the field of building finishing and decoration, which is mainly used to grind and polish the rough surfaces of concrete, cement pavements, cast-in-place floors, walls and the like. Due to the unevenness of the surfaces, they need to be ground by concrete grinders.

[0003] According to the related technology, a concrete grinder comprises a main body, wherein a grinding disk is rotatably connected with the main body, a dust-proof cover is mounted on the outer wall of the main body, the dust-proof cover is a brush ring or a rubber ring, and the lower surface of the dust-proof cover is flush with that of the grinding disk which is positioned within the dust-proof cover. When the grinding disk is pressed against the ground, the dust-proof cover is synchronously pressed against the ground, so that the dust-proof cover blocks gravels or dust to reduce pollution in the working environment when the grinding disk works on the ground.

[0004] However, in the grinding process of a concrete grinder, it is necessary to keep the lower surface of the grinding disk parallel to the ground, and the grinding disk of the concrete grinder is prone to wear after running for a certain period of time so that the lower surface of the grinding disk is not flush with that of the dust-proof cover. Workers need to press and put pressure on the main body to press the lower surface of the dust-proof cover against the ground and to even deform the dust-proof cover, so that the grinding disk can be pressed against the ground. In the above process, due to the different degrees of the pressure by the two hands, the main body and the grinding disk can be easily inclined, thus affecting the precision of the concrete grinder.

### SUMMARY

[0005] The invention provides a concrete grinder and a concrete grinding apparatus so as to improve the precision of the concrete grinder.

[0006] In a first aspect, the invention provides a concrete grinder, which adopts the following technical scheme:

[0007] A concrete grinder, comprising a main body, wherein a grinding disk is rotatably connected with the lower end of the main body, a drive ring is coaxially connected with the outer wall of the main body, the drive ring and the grinding disk are coaxially mounted, a dust-proof cover is coaxially mounted at the lower end of the drive ring, a plurality of drive blocks are disposed on the outer

wall of the main body, a plurality of drive grooves for sliding the drive blocks are formed on the inner wall of the drive ring, the drive grooves are in one-to-one correspondence with the drive blocks, one end of the drive grooves is upward while the other end is downward, and the drive ring is equipped with an adjusting assembly for locking the position of the drive ring.

[0008] According to the above technical scheme, when the grinding disk is worn, the adjusting assembly is opened and the drive ring is pushed, so that the drive blocks slide in the drive grooves, the drive ring drives the dust-proof cover to move in the extending direction of the drive grooves and the dust-proof cover moves along the axial direction of the drive ring. When the lower surface of the dust-proof cover is flush with that of the grinding disk, the adjusting assembly is closed to lock the position of the drive ring and the position of the dust-proof cover is readjusted, whereby the deformation of the dust-proof cover is reduced, the main body and the grinding disk are less likely to incline and the precision of the concrete grinder is improved.

[0009] Optionally, the adjusting assembly comprises a mounting base and a mounting band, wherein the mounting base is disposed on the outer wall of the drive ring, a retractable cavity is formed inside the mounting base, the mounting band passes through the mounting base and fits tightly around the outer wall of the drive ring, both ends of the mounting band are positioned in the retractable cavity, an adjusting bolt is disposed in the retractable cavity, an adjusting threaded hole for threaded connection of the adjusting bolt is formed on the wall of the retractable cavity, the adjusting threaded hole penetrates the outer wall of the mounting base, one end of the adjusting bolt protrudes out of the mounting base and is connected with a force-applying member, and at least one deformable groove is formed on the drive ring.

[0010] According to the above technical scheme, when the drive ring needs to be locked, the force-applying member is rotated to drive the adjusting bolt to rotate, so that the adjusting bolt rotates around its own axis, moves in the adjusting threaded hole, and pulls two ends of the mounting band to tighten the mounting band inside the retractable cavity. Then the mounting band tightens the drive ring and the deformable grooves facilitate deformation, so that the inner wall of the drive ring presses against the outer wall of the main body, thereby completing the locking of the drive ring.

[0011] Optionally, all the drive grooves extend in an inclined manner and are inclined in the circumferential direction of the drive ring.

[0012] According to the above technical scheme, when the mounting band is tightened, the drive ring presses against the main body and is not likely to rotate, so that the drive ring is less likely to move and the stability of the drive ring is improved.

[0013] Optionally, an anti-drop ring and a limiting boss are coaxially disposed on the outer wall of the drive ring, and the two ends of the mounting band along the axial

direction of the drive ring respectively press against the anti-drop ring and the limiting boss.

**[0014]** According to the above technical scheme, the mounting band is positioned between the anti-drop ring and the limiting boss, so that the mounting band is not likely to separate from the drive ring and the stability of the mounting band can be improved.

**[0015]** Optionally, the limiting boss is positioned at one end of the drive ring close to the ground, a socket for mounting the dust-proof cover is coaxially formed on the limiting boss, a mounting ring is mounted on the outer wall of the end of the dust-proof cover away from the ground, mounting bolts are connected in a threaded manner to the end of the limiting boss facing the ground,, and an abutment head for pressing the mounting ring against the socket is disposed on the mounting bolts.

**[0016]** According to the above technical scheme, when the dust-proof cover needs to be mounted, the dust-proof cover is pushed to be insert into the socket. Then the mounting ring is inserted into the socket, and the mounting bolts are all screwed so as to be in threaded connection with the limiting boss until the abutment heads are pressed against the mounting ring, so that the dust-proof cover is not likely to separate from the drive ring and is user-friendly in terms of mounting and operation.

**[0017]** Optionally, a plurality of stiffeners are disposed on the wall of the socket.

**[0018]** According to the above technical scheme, the formation of the socket is not likely to influence the integral strength of the drive ring, and the integral strength of the drive ring is improved instead.

**[0019]** In a second aspect, the invention provides a concrete grinding apparatus, which adopts the following technical scheme:

**[0020]** A concrete grinding apparatus, comprising a concrete grinder and a bracket connected thereto, wherein at least two sliding wheels are mounted at the bottom of the bracket, the bracket is equipped with a mounting frame extending horizontally, the mounting frame is equipped with limiting members, a lifting plate having limiting grooves is disposed on the main body, the limiting members are inserted in the limiting grooves in a sliding manner, the extending direction of the limiting grooves is the same as the axial direction of the drive ring, the mounting frame is in threaded connection with a locking bolt which is used for pressing the lifting plate against the mounting frame, and the axial direction of the locking bolt is perpendicular to the extending direction of the limiting grooves.

**[0021]** According to the above technical scheme, the main body is mounted on the mounting frame, wherein the bracket is pushed and the sliding wheels are turned, so that the concrete grinder can be operated in a user-friendly way.

**[0022]** When the grinding disk is worn, the dust-proof cover is adjusted by taking the above steps to allow the lower surface of the dust-proof cover to be flush with the lower surface of the grinding disk, the locking bolt is

screwed so as not to press against the lifting plate, the main body is pulled to drive the lifting plate to move, the limiting members slide in the limiting grooves until the grinding disk is flush with and presses against the ground, and the locking bolt presses the lifting plate against the mounting frame, so that the main body is lifted or lowered, thus making it easy to operate the concrete grinder and improving the precision of the concrete grinder.

**[0023]** Optionally, the mounting frame is equipped with a supporting wheel for pressing against the ground.

**[0024]** According to the above technical scheme, the stability of the bracket is improved, wherein the concrete grinder is not likely to incline even if it is pressed forward and downward in the actual grinding process, so that the operation of the grinding disk is not prone to be affected and the precision of the concrete grinder is improved.

**[0025]** Optionally, the mounting frame is in threaded connection with an anti-drop bolt, the axial direction of the anti-drop bolt is the same as the extending direction of the limiting grooves, and the lower end of the anti-drop bolt presses against the upper surface of the lifting plate.

**[0026]** According to the above technical scheme, when the main body has been lifted or lowered, the anti-drop bolt is screwed so as to move on the mounting frame until the anti-drop bolt is pressed against the lifting plate, wherein the main body and the lifting plate are not likely to move upward even if the concrete grinder is pressed forward and downward in the actual grinding process, so that the precision of the concrete grinder is improved.

**[0027]** Optionally, the supporting wheel comprises a supporting base and a wheel body, wherein the wheel body is rotatably connected to the supporting base, a lifting threaded rod is rotatably connected to the supporting base, and the lifting threaded rod is in threaded connection with the mounting frame.

**[0028]** According to the above technical scheme, when the supporting wheel is ready to be mounted, the lifting threaded rod is rotated so as to be in threaded connection with the mounting frame, and the lifting threaded rod is rotated so that the height of the supporting wheel is easy to adjust and the mounting frame is kept in a horizontal state.

**[0029]** In conclusion, the present invention has the following beneficial effects:

1. With the presence of the main body, the grinding disk, the drive ring, the dust-proof cover, the drive blocks, the drive grooves and the adjusting assembly, the position of the dust-proof cover is easy to readjust, so that the deformation of the dust-proofing cover is reduced when it is pressed, thereby preventing the main body and the grinding disk from inclining and improving the precision of the concrete grinder;
2. With the presence of the anti-drop ring and the limiting boss, the stability of the mounting band is improved;
3. With the presence of the socket, the mounting ring, the mounting bolts and the abutment heads,

the dust-proof cover is easy to mount;

4. With the presence of the stiffeners, the stability of the drive ring is improved;

5. With the presence of the bracket, the sliding wheels, the mounting frame, the limiting members, the lifting plate, the limiting grooves and the locking bolt, the concrete grinder is easy to operate and the precision of the concrete grinder is improved;

6. With the presence of the supporting wheel, the precision of the concrete grinder is improved;

7. With the presence of the anti-drop bolt, the stability of the main body is improved and the precision of the concrete grinder is further improved;

8. With the presence of the lifting threaded rod, the supporting wheel is easy to mount and adjust.

## BRIEF DESCRIPTION OF THE DRAWINGS

### [0030]

FIG. 1 is a schematic diagram of the overall structure of the embodiments of the present invention;

FIG. 2 is an exploded view of the whole concrete grinder in the embodiments of the present invention;

FIG. 3 is an exploded view of the drive grooves, the drive blocks, the drive ring and the deformable grooves in the embodiments of the present invention;

FIG. 4 is an exploded view of the adjusting assembly in the embodiments of the present invention;

FIG. 5 is an exploded view of the lifting plate, the placement member, the anti-drop bolt, and the locking bolt in the embodiments of the present invention;

FIG. 6 is a schematic diagram of the structure of the supporting wheel in the embodiments of the present invention.

[0031] Reference numerals: 1. main body; 11. grinding disk; 2. drive ring; 21. drive groove; 22. drive block; 23. dust-proof cover; 3. adjusting assembly; 31. mounting base; 32. mounting band; 33. adjusting bolt; 34. force-applying member; 35. retractable cavity; 36. through groove; 37. mounting block; 38. adjusting threaded hole; 39. deformable groove; 4. anti-drop ring; 5. limiting boss; 51. socket; 52. mounting ring; 53. mounting threaded hole; 54. mounting bolt; 55. abutment head; 56. stiffener; 6. bracket; 61. sliding wheel; 7. mounting frame; 71. mounting rod; 711. anti-drop threaded hole; 72. connecting rod; 8. lifting plate; 81. horizontal plate; 82. vertical plate; 83. limiting groove; 84. sliding groove; 9. placement member; 91. limiting member; 101. locking bolt; 102. anti-drop bolt; 103. supporting wheel; 104. supporting base; 105. wheel body; 106. lifting threaded rod.

## DETAILED DESCRIPTION OF THE EMBODIMENTS

[0032] The present invention is described in further detail below with reference to FIGS. 1-6.

[0033] The embodiments of the invention disclose a

concrete grinder.

[0034] As shown in FIGS. 1 and 2, a concrete grinder, comprising a main body 1, wherein a grinding disk 11 is rotatably connected to the lower surface of the main body 1, the grinding disk 11 and the main body 1 have a common axis, and the lower cross-section of the body 1 is circular according to the embodiments of the invention. A drive ring 2 is rotatably fitted around the outer wall of the main body 1, the drive ring 2 and the grinding disk 11 have a common axis, a plurality of drive blocks 22 are fixed to the outer wall of the main body 1, three drive blocks 22 are adopted in the embodiments of the invention, three drive grooves 21 are formed on the inner wall of the drive ring 2, the drive grooves 21 are in one-to-one correspondence with the drive blocks 22, and the drive grooves 21 extend along the outer wall of the drive ring 2.

[0035] One end of the drive grooves 21 starts from the upper surface of the drive ring 2 while the other end of the drive grooves 21 is close to the lower end of the drive ring 2, and all the drive grooves 21 extend in the same direction. An adjusting assembly 3 is mounted around the drive ring 2 for locking the position of the drive ring 2, a dust-proof cover 23 is coaxially mounted at the lower surface of the drive ring 2, and the grinding disk 11 is positioned within the dust-proof cover 23.

[0036] As shown in FIGS. 2 and 3, all the drive grooves 21 extend obliquely in the circumferential direction of the drive ring 2.

[0037] When the grinding disk 11 is worn, the adjusting assembly 3 is opened, the drive ring 2 is turned around its own axis, and the drive blocks 22 slide in the drive grooves 21. Then the drive ring 2 moves along its own axis and forces the dust-proof cover 23 to move, and the adjusting assembly 3 is closed when the lower surface of the dust-proof cover 23 is flush with that of the grinding disk 11, thereby completing the adjustment of the dust-proof cover 23. Therefore, in the above process, additional pressure applied to the main body 1 is reduced, so that the main body 1 and the grinding disk 11 are not prone to incline under the pressure, thus preventing the grinding precision of the grinding disk 11 from being affected and improving the operating precision of the concrete grinder.

[0038] It should be noted that inclined drive grooves 21 stabilize the drive ring 2 more than vertical drive grooves 21, wherein the positions of the drive ring 2 and the dust-proof cover 23 can be locked only by limiting the movement of the drive ring 2 along its own axis, thereby preventing the drive ring 2 from moving the dust-proof cover 23 along its own axis in normal conditions.

[0039] As shown in FIGS. 3 and 4, the adjusting assembly 3 comprises a mounting base 31, a mounting band 32, an adjusting bolt 33 and a force-applying member 34.

[0040] The mounting base 31 is fixed to the outer wall of the drive ring 2, and a retractable cavity 35 is formed inside the mounting base 31, wherein the retractable cavity 35 extends along the diameter of the drive ring 2, and

a through groove 36 which passes through the outer wall of the mounting base 31 is formed in each of the two opposite walls of the retractable cavity 35.

**[0041]** The mounting band 32 is tightly fitted around the drive ring 2, wherein the inner wall of the mounting band 32 is pressed against the outer wall of the drive ring 2, and both ends of the mounting band 32 pass through the through grooves 36 and extend into the retractable cavity 35.

**[0042]** The adjusting bolt 33 passes through the front and the rear ends of the mounting band 32, which are stacked with each other, and a mounting block 37 is disposed on the adjusting bolt 33, which is used for pressing the mounting band 32 against the head of the adjusting bolt 33.

**[0043]** An adjusting threaded hole 38 which penetrates the wall of the retractable cavity 35 is formed on the outer wall of the mounting base 31, wherein the adjusting threaded hole 38 extends along the radial direction of the drive ring 2 and the adjusting bolt 33 is in threaded connection to the adjusting threaded hole 38.

**[0044]** One end of the adjusting bolt 33 protrudes out of the mounting base 31 through the adjusting threaded hole 38, and the force-applying member 34 is fixed to the said end of the adjusting bolt 33.

**[0045]** Three deformable grooves 39 are formed on the inner wall of the drive ring 2, which pass through the outer wall of the drive ring 2 and extend along the axial direction of the drive ring 2.

**[0046]** When the drive ring 2 needs to be locked, the force-applying member 34 is turned to rotate the adjusting bolt 33 around its own axis, the adjusting bolt 33 works threadedly with the adjusting threaded hole 38 to move the adjusting bolt 33 away from the drive ring 2. Then both ends of the mounting band 32 are strained by the adjusting bolt 33, so that the mounting band 32 which passes through the through grooves 36 draws towards the inside of the retractable cavity 35 and tightens the outer wall of the drive ring 2, whereby the deformable grooves 39 are deformed to bring the two opposite walls of the deformable grooves 39 closer to each other. Then the inner wall of the drive ring 2 is tightly pressed against the outer wall of the main body 1, so that the drive ring 2 is not prone to rotate around its own axis and to move.

**[0047]** Similarly, when the drive ring 2 needs to be unlocked, only the force-applying member 34 needs to be rotated to loosen the mounting band 32, thus simplifying the unlocking process. In the meantime, after the unlocking is completed, the force-applying member 34 is pulled to rotate the adjusting bolt 33, the mounting base 31 and the drive ring 2 around the axis of the drive ring 2, thereby enabling the rotation of the drive ring 2. Workers can complete the adjusting process with only one hand, which is user-friendly for them.

**[0048]** The outer wall of the drive ring 2 is coaxially connected with an anti-drop ring 4 and a limiting boss 5, wherein the anti-drop ring 4 is positioned above the limiting boss 5, the mounting band 32 is positioned between

the anti-drop ring 4 and the limiting boss 5, and the anti-drop ring 4 and the limiting boss 5 are fitted respectively against the upper and lower ends of the mounting band 32, so that the mounting band 32 is not prone to separate from the drive ring 2, thereby increasing the stability of the mounting band 32 and improving the clamping effect of the mounting band 32 on the drive ring 2 as well.

**[0049]** It should be noted that the deformable grooves 39 also extend through the anti-drop ring 4, so that the anti-drop ring 4 is less likely to influence the deformation of the drive ring 2.

**[0050]** As shown in FIGS. 2 and 3, the lower surface of the limiting boss 5 is flush with that of the drive ring 2, and a socket 51 is formed on both the lower surfaces of the limiting boss 5 and the drive ring 2, wherein the socket 51 is ring-shaped and shares the axis with the drive ring 2. A mounting ring 52 is coaxially fixed to the outer wall at the upper end of the dust-proof cover 23, which is fitted into the socket 51 together with the mounting ring 52. A plurality of mounting threaded holes 53 are formed on the lower surface of the limiting boss 5, and mounting bolts 54 are connected into the mounting threaded holes 53 in a threaded manner, wherein the mounting bolts 54 are circumferentially positioned around the axis of the drive ring 2 as the center, the mounting bolts 54 and the drive ring 2 have a common axial direction, and the bolt head of the mounting bolts 54 is an abutment head 55.

**[0051]** When the dust-proof cover 23 drives the mounting ring 52 into the socket 51, all the mounting bolts 54 are screwed to be connected with the mounting threaded holes 53 in a threaded way until the abutment heads 55 of the mounting bolts 54 are pressed against the lower surface of the mounting ring 52, so that the mounting ring 52 is pressed tightly against the inside of the socket 51, thereby completing the installation of the dust-proof cover 23. It is convenient for workers to make installation or replacement.

**[0052]** A plurality of stiffeners 56 are fixed onto the wall of the socket 51, which are circumferentially positioned around the axis of the drive ring 2, and the two ends of the stiffener 56 are respectively connected to the two opposite walls of the socket 51, so as to enhance the overall strength of the drive ring 2, wherein the presence of the socket 51 is not likely to affect the overall strength of the drive ring 2.

**[0053]** According to the embodiment of the invention, the principle of embodying a concrete grinder is as follows: when the grinding disk 11 is worn, firstly, the force-applying member 34 is loosened to rotate the adjusting bolt 33 around its own axis which is threadedly connected inside the adjusting threaded hole 38, thereby enabling the adjusting bolt 33 to move the two ends of the mounting band 32 towards the drive ring 2 and loosening the mounting band 32. So far, the deformable grooves 39 return to the natural status, and the force-applying member 34 is pulled to drive the adjusting bolt 33, the mounting band 32 and the drive ring 2 to rotate around the axis of the drive ring 2. Then the drive blocks 22 slide in the drive

grooves 21, so that the drive ring 2 drives the dust-proof cover 23 to move along the axial direction of the drive ring 2 due to the obliqueness of the drive grooves 21.

**[0054]** Then, after the lower surface of the dust-proof cover 23 is flush with that of the grinding disk 11, the force-applying member 34 is tightened to move the adjusting bolt 33 in a direction away from the drive ring 2 and to draw the mounting band 32 which passes through the through groove 36 towards the inside of the retractable cavity 35, so that the outer wall of the drive ring 2 is tightened to deform the deformable grooves 39 and the inner wall of the drive ring is pressed against the outer wall of the main body 1, thereby completing the locking of the drive ring 2.

**[0055]** According to the above procedure, additional pressure applied to the main body 1 is reduced in the process of adjusting the height of the dust-proof cover 23, so that the main body 1 and the grinding disk 11 are not likely to incline and the precision of the concrete grinder can be improved.

**[0056]** The embodiments of the invention also disclose a concrete grinding apparatus.

**[0057]** As shown in FIGS. 1 and 5, a concrete grinding apparatus, comprising a concrete grinder defined in the above embodiments and a bracket 6 connected thereto, wherein the bracket 6 is vertically mounted, two sliding wheels 61 are mounted at the bottom of the bracket 6, a mounting frame 7 which comprises two parallel mounting rods 71 is fixed to the bracket 6 and extends horizontally, a connecting rod 72 connects the two mounting rods 71 to form an "H" shape between the mounting rods 71 and the connecting rod 72 in the embodiments, and the main body 1 is mounted between the two mounting rods 71.

**[0058]** The two opposite sides of the main body 1 respectively correspond to the two mounting rods 71, and the main body 1 is bolted to lifting plates 8 comprising a horizontal plate 81 in a horizontal state and a vertical plate 82 in a vertical state, wherein the horizontal plate 81 is connected with the main body and the vertical plate 82 is positioned at the side of one mounting rod 71 far away from the other mounting rod 71, the mounting rod 71 is bolted with a placement member 9 which is equipped with two limiting members 91 integrally, the vertical plate 82 is fitted adjacent to the placement member 9, and two limiting grooves 83 are vertically formed on the vertical plate 82.

**[0059]** The mounting rod 71 is connected horizontally to a locking bolt 101 in a threaded manner which passes through the placement member 9, and a sliding groove 84 is formed on the vertical plate 82 and is positioned between the two limiting grooves 83.

**[0060]** The upper surface of the mounting rod 71 is equipped with an anti-drop threaded hole 711 penetrating the lower surface of the mounting rod 71, and the anti-drop threaded hole is internally connected with an anti-drop bolt 102 in a threaded manner, wherein the anti-drop bolt 102 is vertically mounted and the lower surface of the anti-drop bolt 102 presses against the upper sur-

face of the horizontal plate 81.

**[0061]** As shown in FIGS. 1 and 6, a supporting wheel 103 comprising a supporting base 104 and a wheel body 105 is mounted on the lower end of the connecting rod 72, wherein the wheel body 105 is rotatably connected to the supporting base 104, the upper end of the supporting base 104 is rotatably connected to a lifting threaded rod 106 which is vertically mounted, and the lifting threaded rod 106 is in threaded connection with the connecting rod 72, thereby making it convenient for workers to mount the supporting wheel 103 on the connecting rod 72.

**[0062]** In the meantime, after the supporting wheel 103 is mounted, the lifting threaded rod 106 is rotated to force the supporting base 104 to move in a vertical direction, which makes it convenient to adjust the horizontal height of the supporting wheel 103, so that the bracket 6 and the mounting frame 7 are kept stable. The supporting wheel 103 is positioned between the two sliding wheels 61 to form a triangle, and in the actual grinding process, even if the concrete grinder is pressed downward and forward, it is not likely to incline and to influence the operation of the grinding disk 11, thereby further improving the precision of the concrete grinder.

**[0063]** According to the embodiments of the invention, the principle of embodying a concrete grinding apparatus is as follows: after the grinding disk 11 is worn and separates from the ground, the above procedure is taken to adjust the dust-proof cover 23, and the locking bolt 101 is then unscrewed so that the bolt head of the locking bolt 101 moves away from the vertical plate 82. Then the main body 1 is moved downward to press the grinding disk 11 against the ground. And then the limiting members 91 slide in the limiting grooves 83, and the locking bolt 101 slides in the sliding groove 84.

**[0064]** After the position of the main body 1 is locked, the locking bolt 101 is tightened so as to be in threaded connection with the mounting rod 71 and to press against the vertical plate 82, and the vertical plate 82 is pressed tightly on the mounting rod 71, thereby completing the adjustment of the position of the main body 1, making it convenient for workers to push the bracket 6 to operate the concrete grinder horizontally on the ground and improving the precision of the concrete grinder.

**[0065]** In the meantime, after the vertical height of the main body 1 is adjusted, the anti-drop bolt 102 is rotated so as to move inside the anti-drop threaded hole 711 until the lower end of the anti-drop bolt 102 presses against the upper surface of the horizontal plate 81, so that in the actual grinding process the anti-drop bolt 102 presses against the main body 1 and the lifting plate 8 to prevent them from shifting upward even if the concrete grinder is pressed downward and forward, thereby further improving the precision of the concrete grinder.

**[0066]** The foregoing are all preferred embodiments of the present invention, which are not intended to limit the scope of protection of the present invention. Therefore, all equivalent changes made according to the structure, shape, and principle of the invention shall be included in

the scope of protection of the invention.

### Claims

1. A concrete grinder, comprising a main body (1), wherein the lower end of the main body (1) is rotatably connected with a grinding disk (11), the outer wall of the main body is rotatably connected with a drive ring (2), the drive ring (2) and the grinding disk (11) are coaxially mounted, a dust-proof cover (23) is coaxially mounted at the lower end of the drive ring, a plurality of drive block (22) are disposed on the outer wall of the main body (1), a plurality of drive grooves (21) for sliding the drive blocks (22) are formed on the inner wall of the drive ring (2), the drive grooves (21) are in one-to-one correspondence with the drive blocks (22), one end of the drive grooves (21) is upward while the other end is downward, and the drive ring (2) is equipped with an adjusting assembly (3) for locking the position of the drive ring (2); The concrete grinder of claim 1, wherein the adjusting assembly (3) comprises a mounting base (31) and a mounting band (32), the mounting base (31) is mounted on the outer wall of the drive ring (2), a retractable cavity (35) is formed in the mounting base, the mounting band (32) passes through the mounting base (31) and fits tightly against the outer wall of the drive ring (2), both ends of the mounting band (32) are positioned in the retractable cavity (35), an adjusting bolt (33) is mounted in the retractable cavity (35), both ends of the mounting band (32) are disposed on the adjusting bolt (33), an adjusting threaded hole (38) for the threaded connection of the adjusting bolt (33) is formed on the wall of the retractable cavity (35), the adjusting threaded hole (38) passes through the outer wall of the mounting base (31), one end of the adjusting bolt (33) protrudes out of the mounting base (31) and is connected with a force-applying member (34), and at least one deformable groove (39) is formed on the drive ring (2); The concrete grinder of claim 2, wherein all the drive grooves (21) extend in an inclined manner and are inclined to the same side around the circumferential direction of the drive ring (2); The concrete grinder of claim 3, wherein an anti-drop ring (4) and a limiting boss (5) coaxially are mounted on the outer wall of the drive ring (2), and the two ends of the mounting band (32) are respectively pressed against the anti-drop ring (4) and the limiting boss (5) along the axial direction of the drive ring (2).
2. The concrete grinder of claim 1, wherein the limiting boss (5) is disposed at the end of the drive ring (2) close to the ground, a socket (51) for inserting the dust-proof cover (23) is coaxially formed on the limiting boss (5), and a mounting ring (52) is mounted on the outer wall of the end of the dust-proof cover
3. The concrete grinder of claim 2, wherein a plurality of stiffeners (56) are disposed on the wall of the socket (51).
4. A concrete grinding apparatus, comprising a concrete grinder of any one of claims 1-3, and a bracket (6) connected thereto, wherein at least two sliding wheels (61) are mounted at the bottom of the bracket (6), a mounting frame (7) with a horizontal extending is mounted on the bracket (7), limiting members (91) are mounted on the mounting frame (7), a lifting plate (8) is mounted on the main body (1), limiting grooves (83) are formed on the lifting plate (8), the limiting members (91) are inserted in the limiting grooves (83) in a sliding manner, the extending directions of the limiting grooves (83) are the same as the axial direction of the drive ring (2), the mounting frame (7) is in threaded connection with a locking bolt (101) used for pressing the lifting plate (8) against the mounting frame (7), and the axial direction of the locking bolt (101) is perpendicular to the extending direction of the limiting grooves (83).
5. The concrete grinding apparatus of claim 4, wherein the mounting frame (7) is equipped with a supporting wheel (103) for pressing against the ground.
6. The concrete grinding apparatus of claim 4, wherein the mounting frame (7) is in threaded connection with an anti-drop bolt (102), the axial direction of the anti-drop bolt (102) is the same as the extending direction of the limiting grooves (83), and the lower end of the anti-drop bolt is pressed against the upper surface of the lifting plate (8).
7. The concrete grinding apparatus of claim 5, wherein the supporting wheel (103) comprises a supporting base (104) and a wheel body (105), the wheel body (105) is rotatably connected to the supporting base (104), a lifting threaded rod (106) is rotatably connected to the supporting base (102), and the lifting threaded rod (106) is in threaded connection with the mounting frame (7).

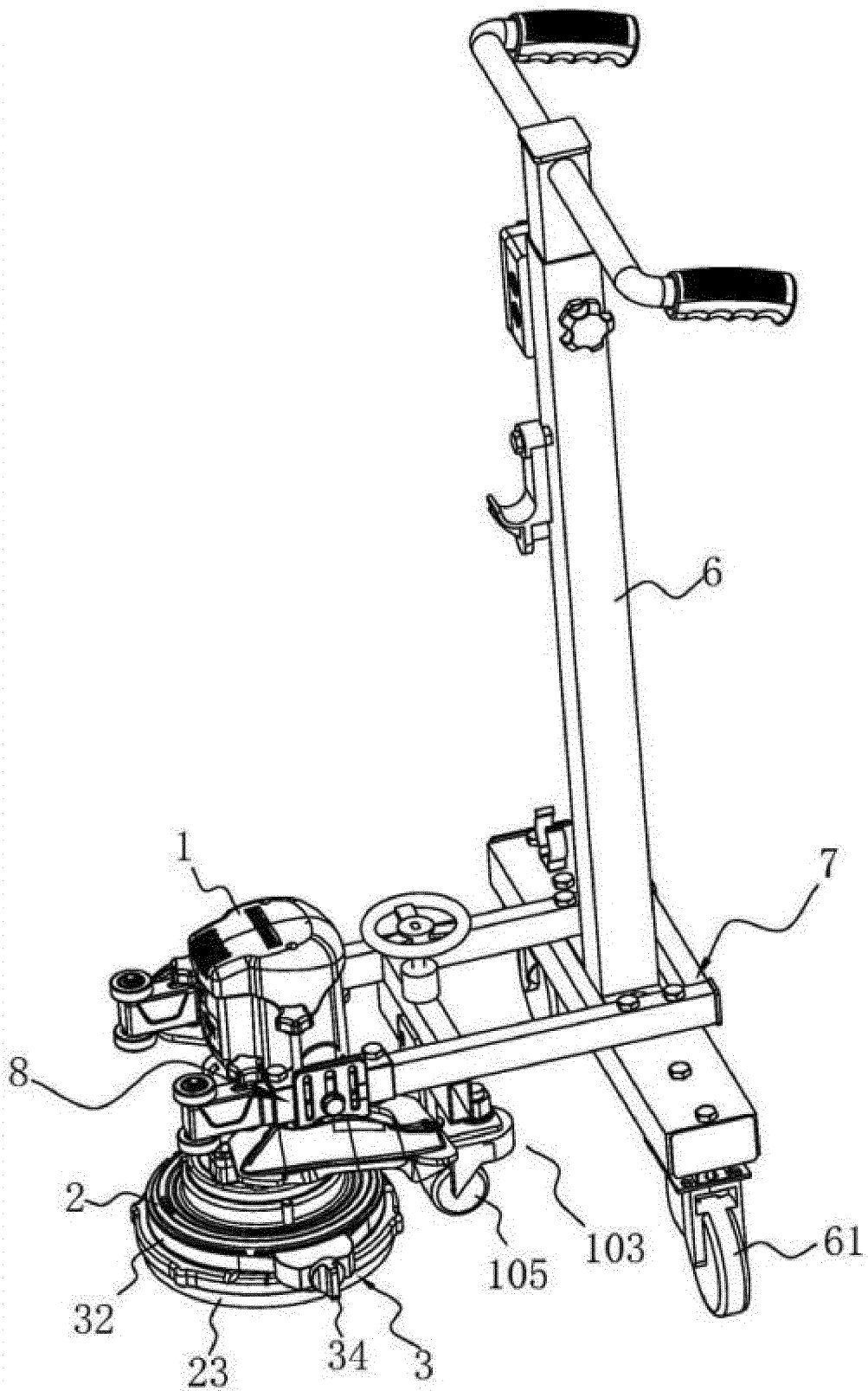

FIG.1

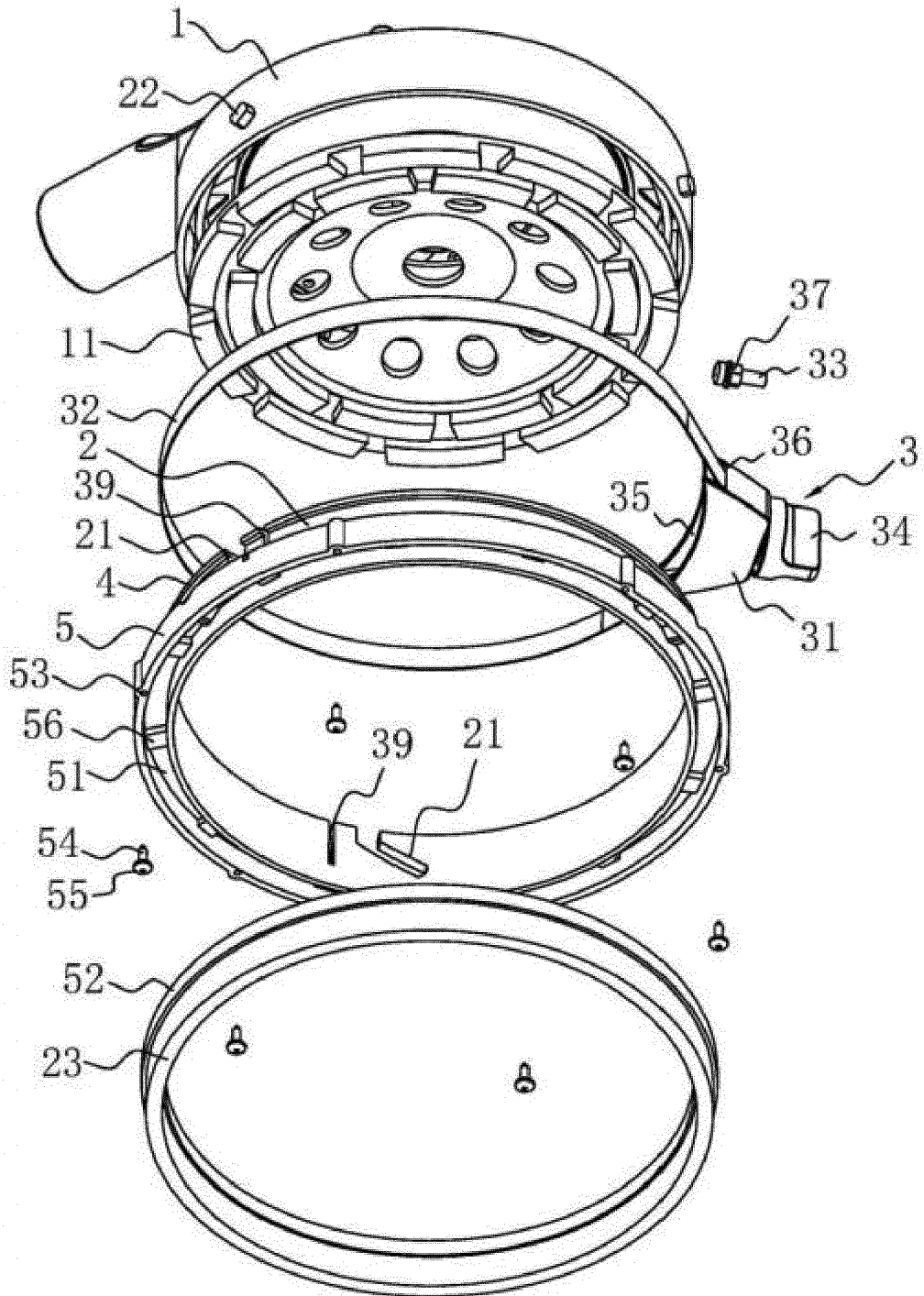

FIG.2

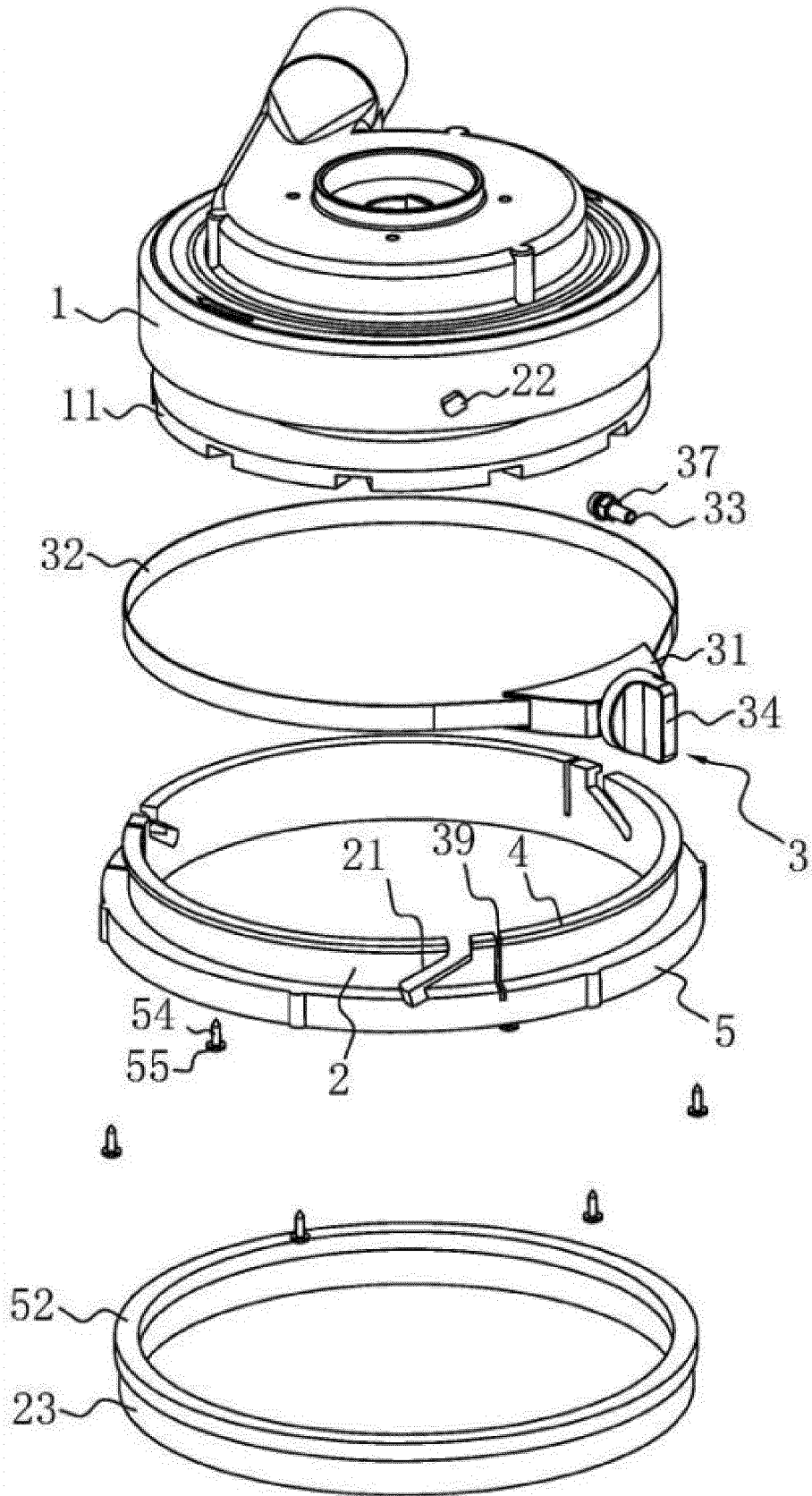

FIG.3

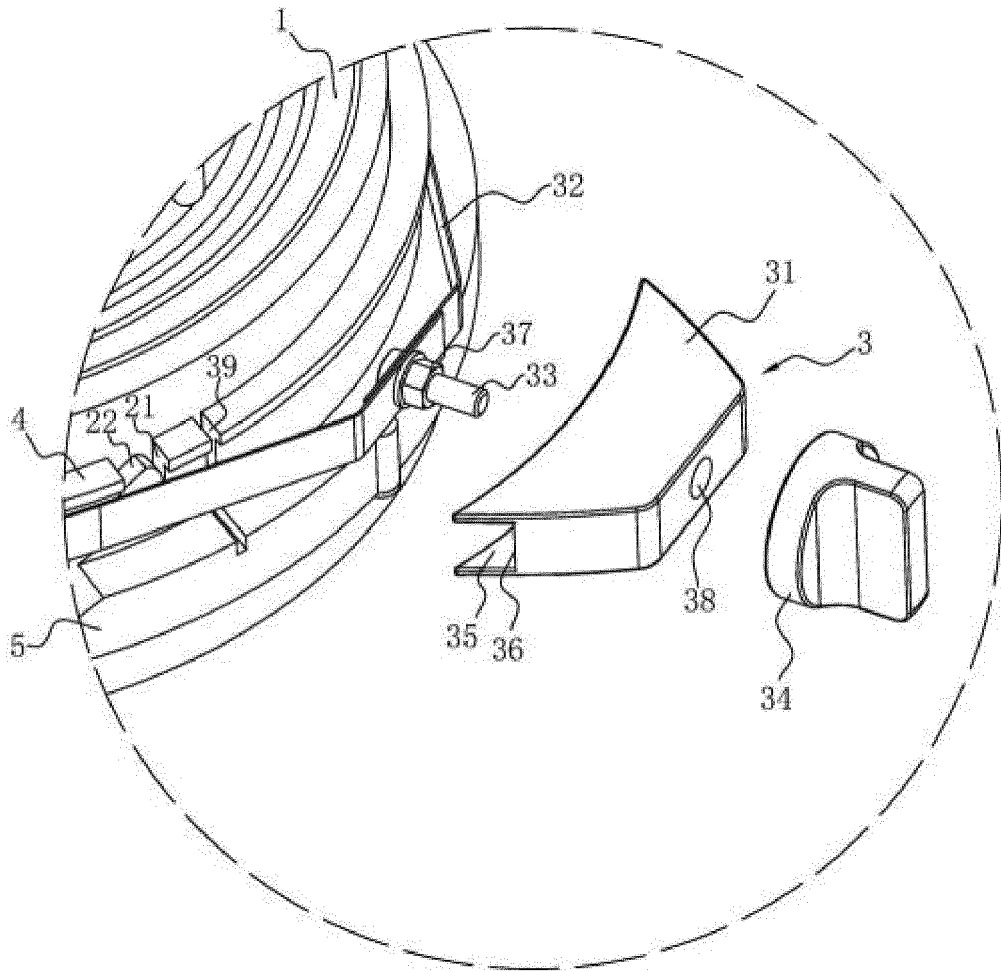

FIG.4

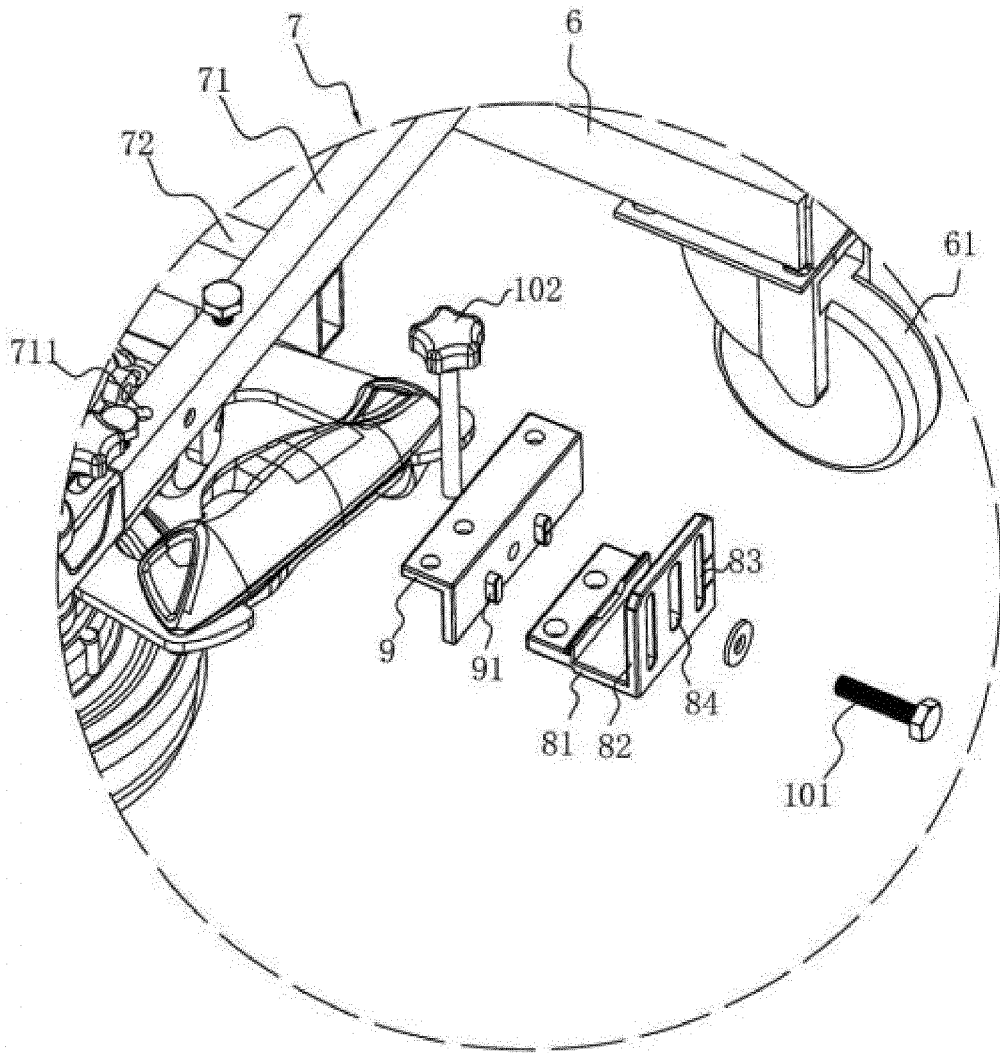

FIG.5

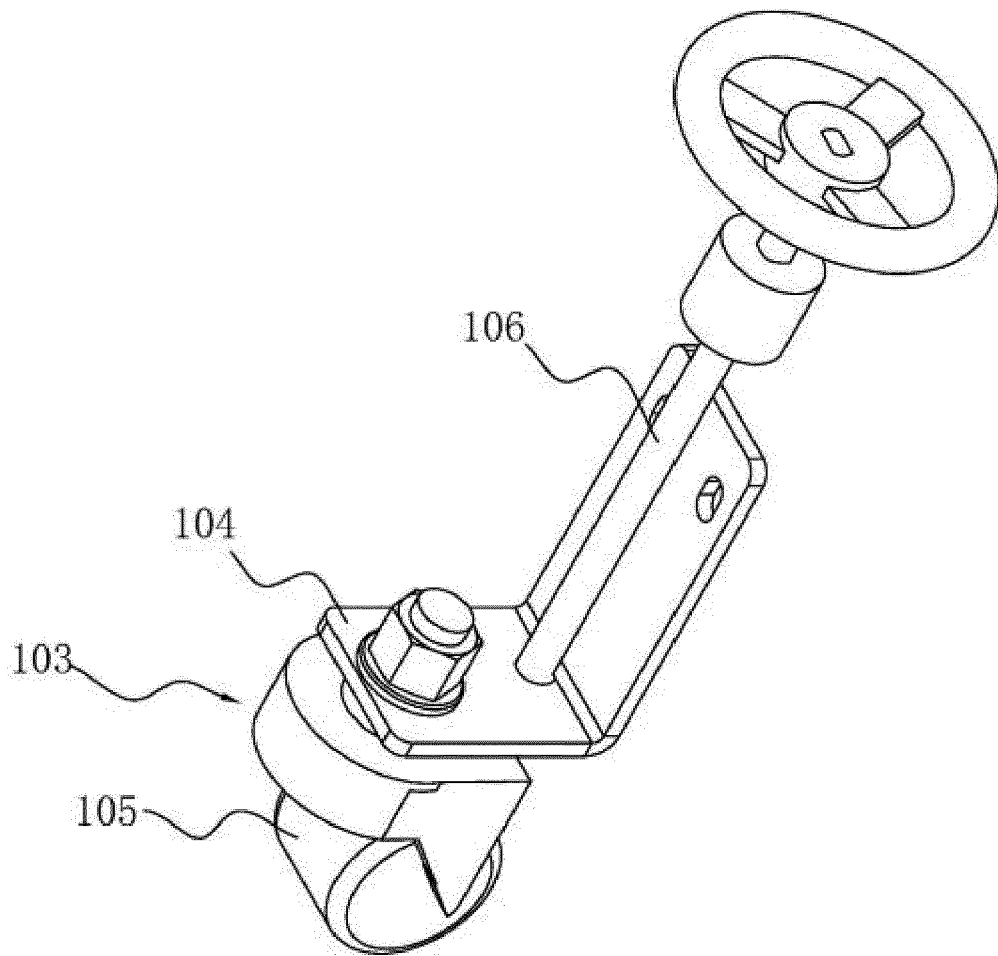

FIG.6