

(19) World Intellectual Property  
Organization  
International Bureau



(43) International Publication Date  
3 March 2005 (03.03.2005)

PCT

(10) International Publication Number  
WO 2005/019066 A1

(51) International Patent Classification<sup>7</sup>: B65D 85/57,  
43/18

(21) International Application Number:  
PCT/CA2004/001521

(22) International Filing Date: 17 August 2004 (17.08.2004)

(25) Filing Language: English

(26) Publication Language: English

(30) Priority Data:  
10/644,813 21 August 2003 (21.08.2003) US

(71) Applicant and

(72) Inventor: MATSUNO, Akihisa [JP/CA]; 101 Burnett  
Road, Victoria, British Columbia V9B 5X8 (CA).

(74) Agents: RATTRAY, Todd A. et al.; OYEN WIGGS  
GREEN & MUTALA, 480 The Station, 601 West Cordova  
Street, Vancouver, British Columbia V6B 1G1 (CA).

(81) Designated States (unless otherwise indicated, for every  
kind of national protection available): AE, AG, AL, AM,

AT, AU, AZ, BA, BB, BG, BR, BW, BY, BZ, CA, CH, CN,  
CO, CR, CU, CZ, DE, DK, DM, DZ, EC, EE, EG, ES, FI,  
GB, GD, GE, GH, GM, HR, HU, ID, IL, IN, IS, JP, KE,  
KG, KP, KR, KZ, LC, LK, LR, LS, LT, LU, LV, MA, MD,  
MG, MK, MN, MW, MX, MZ, NA, NI, NO, NZ, OM, PG,  
PH, PL, PT, RO, RU, SC, SD, SE, SG, SK, SL, SY, TJ, TM,  
TN, TR, TT, TZ, UA, UG, US, UZ, VC, VN, YU, ZA, ZM,  
ZW.

(84) Designated States (unless otherwise indicated, for every  
kind of regional protection available): ARIPO (BW, GH,  
GM, KE, LS, MW, MZ, NA, SD, SL, SZ, TZ, UG, ZM,  
ZW), Eurasian (AM, AZ, BY, KG, KZ, MD, RU, TJ, TM),  
European (AT, BE, BG, CH, CY, CZ, DE, DK, EE, ES, FI,  
FR, GB, GR, HU, IE, IT, LU, MC, NL, PL, PT, RO, SE, SI,  
SK, TR), OAPI (BF, BJ, CF, CG, CI, CM, GA, GN, GQ,  
GW, ML, MR, NE, SN, TD, TG).

**Declaration under Rule 4.17:**

— of inventorship (Rule 4.17(iv)) for US only

**Published:**

— with international search report

[Continued on next page]

(54) Title: OPTICAL DISC STORAGE APPARATUS

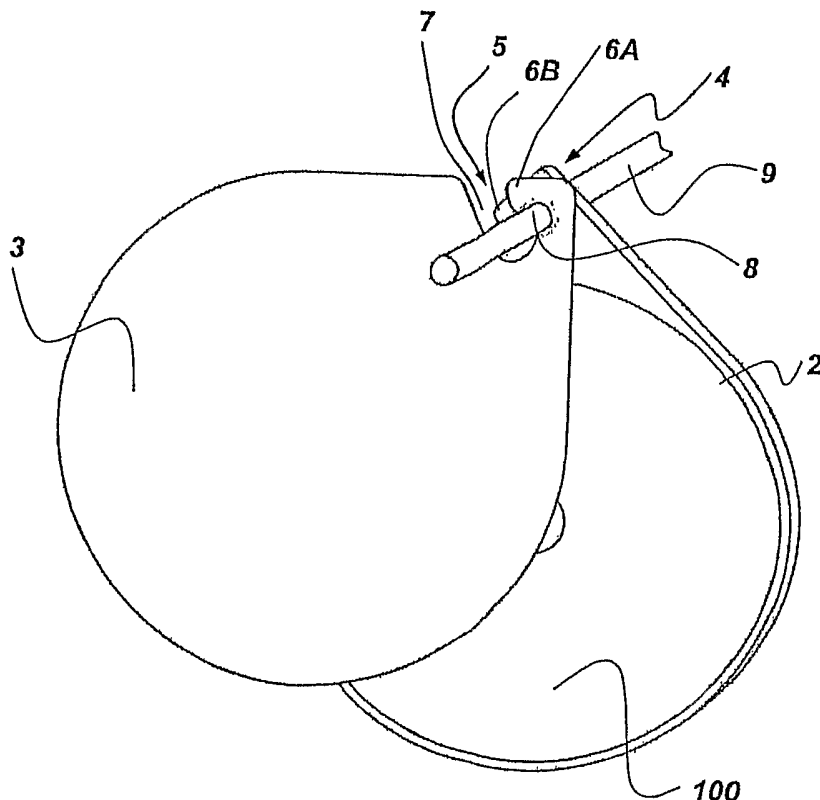

(57) Abstract: A container for housing optical discs (100) includes a base (2) and a lid (3). The disc is housed between the base and the lid. The base may have a retainer for releasably holding an optical disc against a surface thereof. The lid is pivotally coupled to the base by a pivot joint (4) which permits pivotal motion of the lid relative to the base about a pivot axis that is substantially orthogonal to the plane of the disc. The container also includes a hook (5) for coupling the container to a rod (9). The hook may be formed on a perimeter edge of at least one of the base and lid. The inwardmost end of the hook may terminate within the pivot joint. Another embodiment of the invention comprises a shell (512) with a peripheral slot (550) for ejecting the disc with an ejection member (520) in a shape of a hook.

WO 2005/019066 A1



- 
- *before the expiration of the time limit for amending the claims and to be republished in the event of receipt of amendments*
- For two-letter codes and other abbreviations, refer to the "Guidance Notes on Codes and Abbreviations" appearing at the beginning of each regular issue of the PCT Gazette.*

## OPTICAL DISC STORAGE APPARATUS

### Technical Field

**[0001]** The invention relates generally to apparatus for housing,  
5 storing, transporting and/or protecting individual and multiple optical discs.

### Background

**[0002]** Optical disc media is used to store data in various formats,  
10 which may be read by optical means (e.g. laser reading head(s)). For example, optical discs may include digital video discs (DVD's), audio compact discs (CD's), video compact discs (VCD's), super video compact discs (SVCD's), writeable compact discs (CDR's), re-writeable compact discs (CDRW's) and the like. The term "optical disc(s)" is  
15 used in this description and the accompanying claims to include any such optical storage media.

**[0003]** Optical discs are generally sensitive to physical contact, which may cause abrasion, bending and impact damage, for example.  
20 Optical discs may also be sensitive to other environmental factors, such as temperature, which may cause warping of the disc. Optical discs may also be sensitive to contaminants, such as dust, dirt and oil, for example. To protect optical discs and the data contained thereon, it is generally desirable to house individual optical discs in protective  
25 containers when the optical discs are not in use.

**[0004]** Patents related to optical disc storage containers include:

- U.S. Patent No. 4,613,044 (Saito et al.);
- U.S. Patent No. 4,736,840 (Deiglmeier);
- 30 • U.S. Patent No. 4,998,618 (Borgions);
- U.S. Patent No. 5,011,010 (Francis et al.);
- U.S. Patent No. 5,168,991 (Whitehead et al.);
- U.S. Patent No. 5,205,405 (O'Brien et al.); and
- U.S. Patent No. 5,425,451 (Blase).

35 **[0005]** In addition to providing containers for individual optical discs, it is desirable to provide containers for multiple optical discs.

- 2 -

**[0006]** It is also desirable to provide apparatus for storage and/or transport of multiple optical discs and their containers. Prior art techniques for storing multiple optical discs typically involve resting a flat edge of the individual optical disc containers on a shelf of some type.

#### Summary of the Invention

**[0007]** One aspect of the invention provides a container for housing optical discs. The container comprises a base and a lid. An optical disc may be housed between the base and the lid. The base may comprise a retainer for releasably holding an optical disc against a surface thereof. The lid is pivotally coupled to the base by a pivot joint, which permits pivotal motion of the lid relative to the base about a pivot axis that is substantially orthogonal to the plane of the disc.

**[0008]** The container also comprises a hook which may be used to couple the container to a rod. The hook may be formed by a perimeter edge of the lid, a perimeter edge of the base or perimeter edges of both the lid and the base. Alternatively, the hook may be formed by a hook member. The hook may comprise a finger that extends around a portion of the pivot joint. An edge of the finger may define an inwardly extending channel which leads towards the pivot joint and terminates in a bore located within the pivot joint. The width of the bore may be greater than the width of the channel immediately outside of the bore.

**[0009]** The pivot joint may comprise a semi-annular lid member which extends from the lid towards the base in a direction parallel to the pivot axis and a semi-annular base member that extends from the base towards the lid in a direction parallel with the pivot axis. The semi-annular lid and base members may be slidably coupled to one another to enable pivotal movement of the lid with respect to the base. The pivot joint may have a bore through its center. An edge of the bore may be formed by the semi-annular base member and/or the semi-annular lid member. The bore may be semi-circular in shape. One of the lid or the base may have a semi-annular groove that receives the semi-annular member from the opposing one of the lid or the base. The semi-annular member may have a flange and the semi-annular groove may have a

- 3 -

corresponding notch which receives the flange and prevents the lid from inadvertently coming apart from the base.

5 **[0010]** Some embodiments of the container comprise a latch mechanism for maintaining the lid in a closed pivotal orientation with respect to the base. The latch mechanism may comprise one or more protrusions on the lid (or the base) which project into one or more corresponding indentations on the base (or the lid) when the lid is in the closed pivotal orientation.

10

**[0011]** Some embodiments of the container comprise a pivot joint locking mechanism for preventing pivotal movement of the lid with respect to the base. The pivot joint locking mechanism may comprise a shaft, which is slideable to a locking position where a portion of the shaft projects into the pivot joint to prevent pivotal movement of the lid with respect to the base.

15

**[0012]** Another aspect of the invention provides a container for housing an optical disc, wherein the container comprises a hook for coupling the container to a rod. The container may also comprise: a shell shaped to define a space in an interior thereof and having a slot in a peripheral surface thereof for insertion and removal of an optical disc from the space; and an ejection member moveably coupled to the shell for moving between an inward position wherein a first portion of the ejection member is located in the space and an outward position wherein the first portion of the ejection member is located outwardly of the space. Movement of the ejection member from the outward position to the inward position may cause the first portion of the ejection member to abut against an optical disc located in the space and to at least partially eject the optical disc through the slot.

20

25

30

**[0013]** The hook may be formed on a second portion of the ejection member.

35 **[0014]** The shell may comprise a dock for guiding the ejection member between the inward and outward positions. The dock may comprise guide rails for slidably guiding the ejection member between the outward position and the inward position. The dock may comprise a

- 4 -

channel in an outward end thereof for receiving a rod to which the container is coupled.

5 **[0015]** The container may comprise a retainer for applying pressure against a rim of the optical disc when it is located in the space. The container may also comprise a locking mechanism for preventing the optical disc located in the space from inadvertently ejecting. The locking mechanism may comprise a retainer, which is moveable to a locking position where a portion of the retainer partially blocks the slot.

10

**[0016]** Yet another aspect of the invention provides a container for housing optical discs with an ejection mechanism. The container comprises a shell for housing the optical disc and a hook member for coupling the container to a rod. The shell comprises a slot and a dock.  
15 The dock guides the hook member between an inward position, in which the hook member pushes the optical disc out of the shell through the slot, and an outward position, in which the optical disc may be inserted into the shell through the slot.

20 **[0017]** Another aspect of the invention provides apparatus for storage and/or transport of optical disc containers. The apparatus comprise one or more rods onto which the optical disc containers may be mounted by coupling the hook to the rod.

25 **[0018]** Other aspects of this invention include any and all apparatus comprising a novel and inventive feature, combination of features, and/or subcombination of features as described or clearly inferred from this description. Still other aspects of this invention include any and all methods comprising a novel and inventive act, combination of acts,  
30 subcombination of acts, step, combination of steps and/or subcombination of steps as described or clearly inferred from this description.

**[0019]** Further applications of the invention and features of specific  
35 embodiments of the invention are described below.

Brief Description of the Drawings

**[0020]** In drawings which depict non-limiting embodiments of the invention:

- 5 Figure 1 depicts a typical optical disc;  
Figure 2 is a plan view of an optical disc container according to a particular embodiment of the invention in a partially open configuration;  
Figure 3 shows how the Figure 2 container may be coupled to a rod;
- 10 Figure 4 is an isometric view of a particular embodiment of a multiple disc storage apparatus that may be used to store one or more optical disc containers in accordance with the invention;  
Figure 5 is an isometric view of a particular embodiment of a multiple disc storage apparatus that may be used to store one or more optical disc containers in accordance with the invention;
- 15 Figure 6 is an isometric view of a particular embodiment of a multiple disc storage apparatus that may be used to store one or more optical disc containers in accordance with the invention;  
Figure 7 is an isometric view of a particular embodiment of a multiple disc storage apparatus that may be used to store one or more optical disc containers in accordance with the invention;
- 20 Figure 8 is a isometric view of a carrying handle which may be used to transport one or more optical disc containers in accordance with the invention; and  
Figure 9 is an isometric view of a multiple disc carrying case that may be used to store and/or transport one or more optical disc containers in accordance with the invention.
- 25 Figure 10 is a plan view of an optical disc container according to a particular embodiment of the invention in its closed configuration;  
Figure 11 is a plan view of the Figure 10 container in an open configuration;
- 30 Figures 12A and 12B are respectively top and bottom plan views of a lid of the Figure 10 container;  
Figures 13A and 13B are respectively top and bottom plan views of a base of the Figure 10 container;
- 35 Figure 14 is an exploded isometric view of the Figure 10 container;

- 6 -

Figure 15 shows an exploded cross-sectional view of the Figure 10 container;

Figure 16 is an exploded isometric view of an optical disc container according to another embodiment of the invention;

5 Figure 17 is an exploded cross-sectional view of a multiple optical disc container according to another embodiment of the invention;

Figure 18 is a magnified partial isometric view of a pivot joint in accordance with a particular embodiment of the invention;

10 Figure 19 is a magnified plan view of an optional pivot joint locking mechanism in accordance with a particular embodiment of the invention;

Figures 20A and 20B are respectively magnified partial isometric views of the lid and base components of a latch mechanism in accordance with one embodiment of the invention;

15 Figures 21A and 21B are respectively top plan and isometric views of an optical disc container according to another embodiment of the invention;

20 Figure 22 is an isometric cross-sectional view along the line 22-22 of the Figure 21 container;

Figure 23 is an exploded isometric view of the Figure 21 container;

25 Figures 24A and 24B are isometric views showing operation of the ejection mechanism of the Figure 21 container; and

Figure 25 is a plan view of an optical disc container according to another particular embodiment of the invention in a partially open configuration.

30 Detailed Description

**[0021]** Throughout the following description, specific details are set forth in order to provide a more thorough understanding of the invention. However, the invention may be practiced without these particulars. In other instances, well known elements have not been  
35 shown or described in detail to avoid unnecessarily obscuring the invention. Accordingly, the specification and drawings are to be regarded in an illustrative, rather than a restrictive, sense.

- 7 -

**[0022]** The invention relates to containers for housing, storing, transporting and/or protecting one or more individual optical discs. In accordance with one aspect of the invention, a container comprises a base and a lid which are coupled at a pivot joint for pivotal movement relative to one another. When an optical disc is placed between the base and the lid, the lid may be pivoted (relative to the base) to a closed configuration, where the optical disc is encased within the container. The lid may also be pivoted through a range of open configurations, where the optical disc is exposed for removal from the base by a user. The container also comprises a hook. The lid and the base of the container may be shaped to provide the hook on an outer peripheral edge of the container. Alternatively the hook may be provided by a hook member which may be coupled to the lid, the base or to the pivot joint between the lid and base. Preferably, the hook comprises a finger which at least partially surrounds the pivot joint. The hook is selectively engageable with a rod member to store one or more containers in a variety of storage and/or transport apparatus.

**[0023]** Figure 1 shows a typical optical disc **100**, which is substantially planar in shape and which has a data bearing side **102** and a non-data bearing side **104**. Data bearing side **102** comprises optically readable data (not shown) in a data bearing region (not shown). Disc **100** also comprises an annular non-data bearing region **108** which surrounds and is concentric with central bore **110**. The non-data bearing side **104** of optical disc **100** may comprise a label or decal **106**. Such a label may include information and/or graphics which relate to the contents of the data stored in the data bearing region of disc **100**.

**[0024]** Figures 2, 3 depict an optical disc container **1** according to a particular embodiment of the invention. Figures 10-15, 18, 19, 20A, 20B depict various views of an optical disc container **10** according to a different embodiment of the invention. Figures 21-24 depict various views of an optical disc container **510** according to another embodiment of the invention. Figure 25 depicts an optical disc container **610** according to yet another embodiment of the invention. A number of directional conventions are employed when describing optical disc containers in this description and the accompanying claims to help

- 8 -

clarify their meaning. Referring to Figures 2, 11, 21A and 25 and to containers **1**, **10**, **510**, **610** depicted therein:

- 5
- (i) "upward", "upwardly", "upwardmost", "top" and similar words refer to a direction extending out of the page toward the reader;
- (ii) "downward", "downwardly", "downwardmost", "bottom", "lower", "lowermost" and similar words refer to a direction extending out of the page away from the reader;
- 10 (iii) "vertical", "vertically" and similar words refer to either of the upward or downward directions;
- (iv) "inward", "inwardly" and similar words refer to any direction which extends from a perimeter of containers **1**, **10**, **510** and **610** towards an interior of containers **1**, **10**, **510**, **610**; and
- 15 (v) "outward", "outwardly" and similar words refer to any direction which extends from the interior of containers **1**, **10**, **510**, **610** towards the perimeter of containers **1**, **10**, **510**, **610**.

20 Those skilled in the art will appreciate that the particular manner in which the containers are depicted and described is a matter of convenience and that the directional words used in this description and in the accompanying claims should not be interpreted narrowly. In addition to these directional words, the words "semi-annular" and "semi-circular", as used in this description and the accompanying claims, refer

25 respectively to any portion of an annulus and any portion of a circle. These words are specifically not limited to half of an annulus and half of a circle.

30 **[0025]** Figures 2 and 3 depict an optical disc container **1** according to a particular embodiment of the invention. In Figure 2, container **1** is in a partially open configuration. A substantially planar optical disc **100** may be housed in container **1** between base **2** and lid **3**. Base **2** is pivotally coupled to lid **3** at pivot joint **4**, which allows lid **3** to be pivoted relative to base **2**. The pivot axis of pivot joint **4** is substantially

35 orthogonal to the plane of optical disc **100**. In the embodiment of Figures 2 and 3, the pivot axis of pivot joint **4** is substantially orthogonal to the page. Preferably, as shown most clearly in Figure 2, pivot joint **4** provides a bore **8** at or near its center.

- 9 -

[0026] Container **1** also comprises a hook **5** formed by at least one of its perimeter edges. In the illustrated embodiment, hook **5** is formed by a finger **6A** on a perimeter edge of lid **3** and a finger **6B** on a perimeter edge of base **2**. Fingers **6A**, **6B** of hook **5** define a channel **7** which leads inward and terminates at bore **8**. As shown in Figure 3, hook **5** enables container **1** to be coupled to a rod **9** by inserting rod **9** into channel **7** and bore **8**. Because bore **8** is located within pivot joint **4**, lid **3** may still be pivoted relative to base **2** when hook **5** is coupled to rod **9**. Accordingly, the location of bore **8** within pivot joint **4** allows disc **100** to be inserted and/or removed from container **1** without uncoupling container **1** from rod **9** (see Figure 3).

[0027] Because of hook **5**, optical disc container **1** may be coupled to rods in a wide variety of transportation and storage apparatus. Figures 4-9 show various transportation and storage apparatus that take advantage of this feature to store, transport and/or protect optical discs in accordance with the invention.

[0028] Figure 4 depicts a first storage mechanism **410** which comprises a base **414** and a vertically oriented rod **412**. Optical disc containers may be hooked to vertical rod **412**, such that their bases are oriented in a substantially horizontal direction. Rod **412** may optionally be divided into two or more component rods by interposing one or more platforms between the component rods. In the illustrated embodiment, rod **412** is divided into two component rods **412A**, **412B** by intermediate platform **416**. Storage mechanism **410** may be provided with a stopping element **418** which, in the illustrated embodiment, is positioned at the uppermost end of rod **412** to prevent optical disc containers from sliding off of rod **412**. Stopping elements similar to stopping element **418** may be positioned at other location(s) on rod **412** to prevent optical disc containers from sliding thereon.

[0029] Figure 5 depicts another storage mechanism **420** which comprises a plurality of vertically oriented support members **424A**, **424B**, which support a plurality of horizontally oriented rods **422A**, **422B**, **422C**. Optical disc containers may be hooked to rods **422A**, **422B**, **422C**, such that their bases are oriented in a substantially vertical direction. Support members **424A**, **424B** may comprise modular

- 10 -

components **426**, **428** at their uppermost and lowermost extent, such that a plurality of storage mechanisms similar to storage mechanism **420** may be stacked on top of one another to provide increased storage capacity.

5 **[0030]** Figure 6 depicts another storage mechanism **430** which comprises a plurality of vertically oriented support members **434A**, **434B** which support a plurality of horizontally oriented rods **432A**, **432B**. Rods **432A**, **432B** are spaced apart vertically from one another. Optical disc containers may be hooked to rods **432A**, **432B**, such that  
10 their bases are oriented in a substantially vertical direction. Although not illustrated, storage mechanism **430** may be made modular, such that other storage mechanisms similar to storage mechanism **430** may be stacked thereupon to add additional disc storage capacity.

15 **[0031]** Figure 7 depicts another storage mechanism **440** which comprises a horizontally oriented base **442** and a plurality of vertical rods **444A**, **444B**, **444C**. Optionally, as shown in the illustrated embodiment, one or more horizontally oriented intermediate platforms **446A**, **446B** may be located at vertically spaced apart positions along  
20 the length of rods **444A**, **444B**, **444C**. Optical disc containers having hooks may be housed by storage mechanism **440** by hooking the containers to any one of rods **444A**, **444B**, **444C**, such that their bases are oriented in a substantially horizontal direction. In addition, conventional optical disc containers without hooks may be housed by  
25 storage mechanism **440**. Such conventional optical disc containers may be stacked in a horizontal orientation between rods **444A**, **444B**, **444C** in region **448** of base **442** or regions **447A**, **447B** of platforms **446A**, **446B**. Storage mechanism **440** may be provided with stopping elements **449A**, **449B**, **449C** which, in the illustrated embodiment, are positioned  
30 at the uppermost ends of rods **444A**, **444B**, **444C** to prevent optical storage discs from sliding off of rods **444A**, **444B**, **444C**. Stopping elements similar to stopping elements **449A**, **449B**, **449C** may be located at other positions on rods **444A**, **444B**, **444C** to prevent optical discs from sliding thereon.

35 **[0032]** Figure 8 depicts an optical disc transportation apparatus **450**, which comprises a rod **454** and a handle **456** coupled to rod **454** at either end thereof. One or more optical disc containers **452** may be

- 11 -

5 hooked to rod **454**. A user may carry transportation apparatus **450** using handle **456**. Transportation apparatus **450** may comprise one or more stopping elements (not shown) which may be positioned along the length of rod **454** to prevent movement of optical disc containers **452** thereon.

10 **[0033]** Figure 9 depicts an optical disc transportation apparatus **460** which comprises a bag **468** having a handle **466** and a rod **464**. One or more optical disc containers **462** may be hooked to rod **464** such that optical disc containers are housed inside bag **468**. Bag **468** may comprise a lid **465**, which may be closed using fastening element **467**. Fastening element may comprise one or more hook and loop fasteners or zippers, for example.

15 **[0034]** Those skilled in the art will appreciate that there are many alternative storage and transportation apparatus comprising rods to which any of the optical disc container described herein may be coupled by their respective hooks. The invention should be understood to incorporate any such apparatus.

20 **[0035]** Figures 10-15, 18, 19, 20A and 20B depict a container **10** according to another particular embodiment of the invention. Figure 10 shows a top plan view of container **10** in its closed configuration. A substantially planar optical disc **100** (Figure 1) may be encased between  
25 base **12** and lid **14**. Preferably, optical disc **100** is removably held in base **12** via its central bore **110** by disc retainer **18**. Base **12** is pivotally coupled to lid **14** at pivot joint **16**. Pivot joint **16**, which is shown and described in detail in Figure 18 and the accompanying discussion below, preferably enables lid **14** to be pivoted about pivot axis **16A** (Figure 15)  
30 through a relatively large angular range relative to base **12**, providing optical disc container **10** with a wide range of open configurations. Figure 11 depicts container **10** in a particular open configuration, wherein lid **14** is pivoted relative to base **12**, such that optical disc **100** may be disengaged from retainer **18** and removed from between lid  
35 **14** and base **12**. Container **10** also comprises a hook **62** which may be used to hang container **10** from a rod (not shown) or to otherwise couple container **10** to a rod. In the illustrated embodiment, hook **62** comprises

- 12 -

a semi-circular shaped central bore **64** defined by finger **63**, which at least partially surrounds pivot joint **16**.

**[0036]** As best seen in Figures 13A, 13B and 14, the perimeter of base **12** comprises a pair of straight edges **20A** and **20B** that extend substantially orthogonally from the sides of pivot joint **16** (Figure 10). At their distal ends, straight edges **20A** and **20B** respectively become arcuate edges **22A**, **22B**, which have a center of curvature located approximately at the center **40** of base **12**. Arcuate edges **22A**, **22B** extend to meet either end of straight edge **24**, which forms part of an optional latch mechanism **26** (Figure 10). Optional latch mechanism **26** is shown and described in detail in Figures 20A, 20B and accompanying discussion below. As shown in Figure 13B, the bottom side **28** of base **12** may be substantially planar. The upper side of base **12** (Figure 13A) may comprise a number of features including retainer **18**, base plane **30**, rail **32** and annular platform **34**. The upper side of base **12** (Figure 13A) also comprises a number of features that form part of pivot joint **16** (Figure 18) and latch mechanism **26** (Figure 20A, 20B), which are explained further below. Base **12** may be made from a variety of suitable materials, such as plastic, for example. Base **12** may be transparent, so that the contents of container **10** may be seen through base **12**.

**[0037]** In the illustrated embodiment, base **12** includes retainer **18**, which holds optical disc **100** in place in base **12**. In the illustrated embodiment, retainer **18** comprises a plurality of upwardly extending, deformable retainer members **36A**, **36B**, **36C**, which are spaced apart from one another about the circumference of a circle **38**. Circle **38** may be approximately the same size as the central bore **110** of optical disc **100**. In operation, optical disc **100** is located above base **12** with its central bore **110** approximately aligned with retainer **18**. A user then gently pushes optical disc **100** toward base **12**, such that retainer members **36** are deflected inwardly as they slide through the central bore **110** of optical disc **100**. The inward deflection of retainer members **36** causes retainer members **36** to exert outward pressure on the rim of central bore **110**. This outward pressure holds optical disc **100** in place in base **12**.

- 13 -

**[0038]** Those skilled in the art will appreciate that retainer **18** may be implemented via a large number of alternative embodiments (not shown). For example, retainer members **36** may extend inwardly prior to extending upwardly. Additionally or alternatively, one or more of  
5 retainer members **36** may comprise an outwardly extending lip (not shown) which helps to hold optical disc **100** in base **12**. Additionally or alternatively, retainer **18** may comprise a plurality of upwardly extending, non-deflecting guide rails (not shown) which are interposed  
10 between retainer members **36**. Such guide rails may have a slightly smaller radius of curvature than retainer members **36**, such that the guide rails maintain the position of optical disc **100** within base **12**. In general, retainer **18** may comprise any of the different types of optical disc retaining apparatus used with optical disc containers known in the art or developed in the future.

15

**[0039]** As shown in Figure 13A, the upper side of base **12** comprises base plane **30**. Base plane **30** is partially surrounded by rail **32** which extends upwardly from a perimeter of base plane **30** and which helps to contain and protect optical disc **100** in base **12**.  
20 Preferably, as shown best in Figure 14, rail **32** is located around the entire perimeter of base plane **30**, except in the region around latch mechanism **26** (Figure 10), where there is a gap **42** in rail **32**. Gap **42** facilitates handling of optical disc **100** and removal of optical disc **100** from base **12**. In alternative embodiments, rail **32** may completely  
25 surround base plane **30** or rail **32** may comprise a plurality of spaced apart arcuate sections. In further alternative embodiments, rail **32** is not present and retainer **18** holds optical disc **100** in place in base **12** without the assistance of a rail.

**[0040]** Base **12** may comprise an annular platform **34** which provides a plane that is raised upwardly from base plane **30**. When optical disc **100** is held in base **12** by retainer **18**, the annular non-data bearing portion **108** of disc **100** rests on annular platform **34**, such that the data bearing portion **102** of optical disc **100** is spaced apart slightly  
35 from base plane **30**. In this manner, annular platform **34** helps to prevent optical disc **100** from being damaged and to prevent the data stored on optical disc **100** from being corrupted. In alternative embodiments of the invention, platform **34** may comprise a plurality of

- 14 -

platform elements which are raised from base plane **30**. Such platform elements may have a wide variety of shapes, but should be positioned to abut the annular non-data bearing portion **108** of optical disc **100** when optical disc **100** is held in base **12**. In other alternative embodiments, platform **34** is not present.

**[0041]** As shown in Figures 12A, 12B and 14, the perimeter of lid **14** has a shape similar to that of base **12** with straight edges **44A**, **44B** extending from the sides of pivot joint **16** (Figure 10) to respectively meet arcuate edges **46A**, **46B**. Arcuate edges **46A**, **46B** extend to meet either end of straight edge **48**, which forms part of a optional latch mechanism **26** (Figure 10). As shown in Figure 12A, the top side **50** of lid **12** may be substantially planar. As shown in Figure 14, the bottom side of lid **14** may comprise a plurality of inwardly extending tabs **52**. The bottom side of lid **14** may also comprise a number of features that form part of pivot joint **16** (Figure 18) and latch mechanism **26** (Figures 20A, 20B), which are explained further below. Lid **14** may be made from a variety of suitable materials, such as plastic, for example. Preferably, lid **14** is transparent so that the contents of container **10** may be seen through lid **14**.

**[0042]** Container **10** may also comprise index label **56** and insert **54** (see Figure 14). Index label **56** and insert **54** may be made of cardboard, paper, and/or other suitable materials, and may comprise information and/or graphics relating to the data stored on optical disc **100**. For example, in the case where optical disc **100** is a CDR, index label **56** and/or insert **54** may contain information about the data recorded on the CDR. Depending on the nature of optical disc **100**, index label **56** and/or insert **54** may be blank, such that information may be recorded on index label **56** and/or insert **54** by users. Index label **56** and insert **54** may comprises a single sheet or a plurality of sheets.

**[0043]** Index label **56** may contain adhesive on a bottom side thereof, such that a user may adhere index label **56** to base plane **30** of base **12**. Alternatively, index label **56** may be adhered to base plane **30** during fabrication of container **10**. In still further alternative embodiments, the bore **58** of index label **56** may form a friction fit with platform **34** of base **12**. Index label **56** may also be loose. Inwardly

- 15 -

extending tabs **52** on lid **14** may function to hold insert **54** (see Figure 14). Insert **54** may also be loose.

5 [0044] As shown in Figure 14, index label **56** may also comprise an outwardly protruding tongue **60**, which extends through gap **42** and outwardly beyond flat edge **24** of base **12**. Tongue **60** may comprise information about the data stored on optical disc **100**. The information located on tongue **60** may be viewed by a user without having to open container **10** or having to view the top or bottom sides of container **10**.

10

[0045] As discussed above, lid **14** is pivotally coupled to base **12** at pivot joint **16**. Figure 18 shows a magnified view of a pivot joint **16** according to a particular embodiment of the invention. In the illustrated embodiment, pivot joint **16** comprises a semi-annular shaped lid member **66**, which extends downwardly from a lower surface of lid **14**, a semi-annular shaped base member **70**, which extends upwardly from an upper surface of base **12**, and a semi-annular groove **72** in the upper surface of base **12**. When assembled, semi-annular lid member **66** projects downwardly into groove **72** and semi-annular base member **70** projects upwardly into a semi-circular central bore **77** defined by an inner surface of semi-annular lid member **66**. A lower portion of semi-annular lid member **66** fits slidably within groove **72** and an upper portion of semi-annular base member **70** fits slidably against the inner surface of semi-annular lid member **66** to allow pivotal motion of lid **14** with respect to base **12**.

15

20

25

[0046] In the illustrated embodiment, semi-annular lid member **66** comprises a flange **68** at its lowermost extent and groove **72** comprises a correspondingly shaped notch **74** at its lowermost extent. When container **10** is assembled (i.e. base **12** is coupled to lid **14**), flange **68** and notch **74** cooperate to facilitate the pivotal motion of pivot joint **16** and to prevent lid **14** from inadvertently coming apart from base **12**. Preferably, as shown in Figure 18, the transverse extent of flange **68** is relatively small, so that a user can separate lid **14** from base **12**, if desired, by deforming one or more of the components of pivot joint **16**. Those skilled in the art will appreciate that the location of flange **68** at the downwardmost extent of semi-annular lid member **66** and the location of notch **74** at the downwardmost extend of groove **72** are

30

35

- 16 -

design choices. The same functionality could be achieved by locating flange **68** and notch **74** at other locations.

**[0047]** Referring to Figures 10, 11 and 18, container **10** comprises  
5 a hook **62** which may be used to hang container **10** from a rod (not  
shown) or to otherwise couple container **10** to a rod. In the illustrated  
embodiment, hook **62** comprises a finger **63**, which extends at least  
partially around a semi-circular bore **64** in pivot joint **16**. In the  
10 illustrated embodiment, semi-circular bore **64** is defined by the inner  
surface of semi-annular base member **70** of pivot joint **16**. The curved  
shape of finger **63** forms a curved channel **76**, which leads from semi-  
circular bore **64** and opens onto one of the straight edges **20A** on the  
perimeter of container **10**. The width of channel **76** may be less than  
15 the diameter of bore **64**. In particular, the width of channel **76** at the  
entrance **78** to bore **64** may be less than the diameter of bore **64**, such  
that a rod may cause a slight deformation of the sidewalls of channel **76**  
when inserted into bore **64**. In this manner, a rod may be secured in  
bore **64** of hook **62** once inserted therein, but will be removable by a  
20 user if desired. As shown in Figure 11, finger **63** may comprise a lid  
finger member **63A** and a base finger member **63B**. In alternative  
embodiments, finger **63** may comprise only lid finger element **63A** or  
only base finger element **63B**.

**[0048]** Figures 20A and 20B depict a magnified view of a latch  
25 mechanism **26** according to a particular embodiment of the invention.  
Latch mechanism **26** comprises a latch tab **80** which projects  
downwardly from straight edge **48** of lid **14**. Latch tab **80** comprises a  
plurality of latch protrusions **82A**, **82B** which project inwardly from its  
inner surface. Latch mechanism **26** also comprises a corresponding  
30 plurality of latch indentations **84A**, **84B** in base **12**. Latch indentations  
**84A**, **84B** may be formed in rail **32** of base **12**, for example. When  
container **10** is in its closed configuration, as depicted in Figure 10,  
latch protrusions **82A**, **82B** project into latch indentations **84A**, **84B** to  
maintain the angular position of lid **14** relative to base **12** and to thereby  
35 secure container **10** in its closed configuration. In order to open  
container **10**, a user may cause latch tab **80** to deform outwardly by a  
small amount, disengaging latch protrusions **82A**, **82B** from latch

- 17 -

indentations **84A**, **84B** and thereby allowing lid **14** to be pivoted relative to base **12**.

**[0049]** Latch mechanism **26** depicted in Figures 20A and 20B and  
5 discussed above represents only one type of latch mechanism which  
functions to prevent lid **14** from pivoting relative to base **12**. Those  
skilled in the art will appreciate that there are a variety of mechanisms  
similar to latch mechanism **26** and that such mechanisms may vary  
10 considerably, while achieving the desired functionality. By way of non-  
limiting examples: a latch mechanism may be located at a different  
position on a perimeter edge of container **10**; a latch mechanism may  
comprise protrusions and indentations of different shapes or locations;  
and/or a latch mechanism may comprise different types of fastener(s)  
altogether.

15

**[0050]** Figure 19 depicts a magnified plan view of an optional  
pivot joint locking mechanism **86**, which may be used in addition to, or  
as an alternative to, latch mechanism **26** to prevent lid **14** from pivoting  
relative to base **12**. Locking mechanism **86** comprises a shaft **90**, which  
20 has a user actuatable end **96** and a distal end **94**. A user may push or  
pull the actuatable end **96** of shaft **90** to slide shaft **90** backward and  
forward (i.e. in the directions indicated by double-headed arrow **92**)  
within slot **88**. The user actuatable end **96** of shaft **90** may comprise a  
flange **95** which prevents shaft **90** from traveling too far into slot **88**. In  
25 the illustrated embodiment, shaft **90** and slot **88** are located in base **12**.  
When shaft **90** is fully inserted into slot **88**, its distal end **94** interrupts  
the operation of pivot joint **16**. More particularly, the distal end **94** of  
shaft **90** interrupts the movement of semi-annular lid member **68** within  
groove **72** (see Figure 18), thereby preventing the operation of pivot  
30 joint **16**.

**[0051]** Figure 16 is an exploded view of an optical disc container  
**210** according to an alternative embodiment of the invention wherein  
compound base **212** comprises an intermediate base member **212B**  
35 which is coupled to lower base member **212A**. Container **210** has  
substantially the same perimeter shape as container **10** described above  
(see Figure 14), but container **210** may be slightly thicker from its  
uppermost surface to its lowermost surface. Container **210** may be used

- 18 -

to contain optical discs **100** (Figure 1) that are prerecorded with media content.

**[0052]** Lower base member **212A** comprises a base plane **230A**  
5 and a rail **232A**. In the illustrated embodiment, rail **232A** extends upwardly from the perimeter of base plane **230A** except in the region of gap **242A**, which may be used for a latch mechanism (not shown), and in the channel region **276A** for hook **262**. Rail **232A** may comprise a plurality of inwardly opening indentations **231A** which are positioned at  
10 spaced apart locations thereon. Intermediate base member **212B** fits slidably into lower base member **212A**. Intermediate base member **212B** comprises a base plane **230B** and a rail **232B**. In the illustrated embodiment, rail **232B** extends upwardly from the perimeter of base plane **230B** except in the region of gap **242B**, which may be used for the  
15 latch mechanism and in the channel region **276B** for hook **262**. Rail **232B** may comprise a plurality of outwardly projecting protrusions **231B** which are positioned at spaced apart locations thereon. The upper side of intermediate base member **212B** also comprises platform **234** and retainer **218**, which may be substantially similar to platform **34** and  
20 retainer **18** described above in relation to container **10**.

**[0053]** Intermediate base member **212B** may be coupled to lower base member **212A** to form compound base **212** by inserting  
intermediate base member **212B** into lower base member **212A**, such  
25 that protrusions **231B** project into indentations **231A**. Once intermediate base member **212B** and lower base member **212A** are coupled, compound base **212** functions in a manner substantially similar to base **12** described above in relation to container **10**.

**[0054]** Lower base member **212A** is preferably made of  
30 transparent material, such as clear plastic, for example. Lower label **211** may be inserted between lower base member **212A** and intermediate base member **212B**. Lower label **211** may be made of cardboard, paper or other suitable materials, and may comprise  
35 information and/or graphics relating to the data stored on optical disc **100**. For example, in the case where optical disc **100** is a DVD, lower label **211** may contain graphics and information about the video programming stored on the DVD. Depending on the nature of optical

- 19 -

disc **100**, lower label **211** may be blank, such that information may be recorded thereon.

5 [0055] Lid **214** of container **210** may be substantially the same as lid **14** described above in relation to container **10**. The bottom side of lid **214** may comprise tabs **252** which extend inwardly from spaced apart locations on the perimeter of lid **214**. Tabs **252** may function to hold insert **254**. Tabs **252** and insert **254** may be substantially similar to tabs **52** and insert **54** described above in relation to container **10**.

10

[0056] In other respects, container **210** may be substantially similar to container **10** of Figures 10-15, 18, 19, 20A-20B. In particular, hook **262**, pivot joint **216** and latch **226** of container **210** may be substantially similar to hook **62**, pivot joint **16** and latch **26** of container **10**.

15

Accordingly, the specifics of these components of container **210** are not described further herein.

[0057] Figure 17 is a cross-sectional view of a multiple optical disc container **310** according to another alternative embodiment of the invention. Multiple disc container **310** comprises a base **312** and a lid **314** which may be substantially similar to base **12** and lid **14** described above in relation to container **10**. Multiple disc container **310** also comprises intermediate member **302**. Intermediate member **302** has a bottom side **304**, which comprises features which are substantially similar to the bottom side of lid **314**, and an upper side **306**, which comprises features that are substantially similar to the upper side of base **312**. Base **312**, lid **314** and intermediate member **302** may be pivotally coupled to one another at pivot joint **316**, such that base **312**, lid **314** and intermediate member **302** may each pivot independently with respect to one another. When coupled in this manner, a first optical disc (not shown) may be retained between the upper side of base **312** and the bottom side **304** of intermediate member **302** and a second optical disc may be retained between the upper side **306** of intermediate member **302** and the bottom side of lid **314**.

35

- 20 -

**[0058]** Pivot joint **316** allows base **312**, lid **314** and intermediate member **302** to independently pivot with respect to one another. The bottom side **304** of intermediate member **302** may comprise pivot joint components that are substantially similar to the pivot joint components of lid **14** of container **10** described above (see Figure 18). More specifically, the bottom side **304** of intermediate member **302** may comprise a downwardly extending semi-annular member **366'**, which partially surrounds a perimeter of a semi-circular bore **377'** and which may have a flange **368'** at its lowermost extent. When intermediate member **302** is coupled to base **312**, downwardly extending semi-annular member **366'** projects downwardly into groove **372** of base **312** and upwardly extending semi-annular base member **370** projects upwardly into semi-circular bore **377'**. Downwardly extending semi-annular member **366'** fits slidably within groove **372** and semi-annular base member **370** fits slidably against an inner surface of semi-annular member **366'** to allow pivotal motion of intermediate member **302** with respect to base **312**. Flange **368'** on the lowermost extent of downwardly extending semi-annular member **366'** may fit into a correspondingly shaped notch (not shown) in groove **372** to prevent intermediate member **302** from inadvertently coming apart from base **312**. If desired, a user may separate base **312** and intermediate member **302** by deforming one or more of semi-annular members **366'**, **370** or groove **372**.

**[0059]** The upper side **306** of intermediate member **302** may comprise pivot joint components that are substantially similar to the pivot joint components of base **12** of container **10** described above (see Figure 18). More specifically, the upper side **306** of intermediate member **302** may comprise a semi-annular groove **372'** and an upwardly extending semi-annular member **370'**. When intermediate member **302** is coupled to lid **314**, downwardly extending semi-annular lid member **366** projects downwardly into groove **372'** and upwardly extending semi-annular member **370'** projects upwardly into bore **377** of semi-annular lid member **366**. Semi-annular lid member **366** fits slidably within groove **372'** and upwardly extending semi-annular member **370'** fits slidably against an inner surface of semi-annular lid member **366** to allow pivotal motion of intermediate member **302** with respect to lid **314**. Flange **368** on the lowermost extent of semi-annular

- 21 -

lid member **366** may fit into a correspondingly shaped notch (not shown) in groove **372'** to prevent intermediate member **302** from inadvertently coming apart from lid **314**. If desired, a user may separate lid **314** and intermediate member **302** by deforming one or more of semi-annular members **366**, **370'** or groove **372'**.

[0060] Container **310** may be provided with an independent latch mechanism **326** between the bottom side **304** of intermediate member **302** and base **312** and an independent latch mechanism **327** between the upper side **306** of intermediate member **302** and lid **314**. More particularly, the bottom side **304** of intermediate base member **302** may comprise a downwardly extending latch tab **380'** with latch protrusions **382'**. Latch tab **380'** and latch protrusions **382'** may function in a manner substantially similar to latch tab **80** and protrusions **82A**, **82B** of container **10** (see Figures 20A, 20B). Together, latch tab **380'** and latch protrusions **382'** on the bottom side **304** of intermediate member **302** and latch indentations **384** on base **312** provide a user-openable latch mechanism **326** between base **312** and intermediate member **302**. The top side **306** of intermediate base member **302** may comprise a plurality of latch indentations **384'**. Latch indentations **384'** may function in a manner substantially similar to latch indentations **84A**, **84B** of container **10** (see Figures 20A, 20B). Together, latch indentations **384'** on the upper side **306** of intermediate member **302** and latch tab **380** and latch protrusions **382** on lid **314** provide a user-openable latch mechanism **327** between lid **314** and intermediate member **302**.

[0061] In other respects, container **310** may be substantially similar to container **10** of Figures 10-15, 18, 19, 20A and 20B. In particular, hook **362**, of container **310** may be substantially similar to hook **62** of container **10**. Finger **363** of hook **362** may comprise a lid finger member, a base finger member and an intermediate finger member. In alternative embodiments, finger **363** may comprise any one or any pair of a lid finger member, a base finger member and an intermediate finger member. The additional specifics of hook **362** are not described further herein.

- 22 -

[0062] Those skilled in the art will appreciate that container **310** is not limited to having a single intermediate member **302**. Container **310** may comprise a plurality of intermediate members **302** to provide a container capable of housing a plurality of optical discs. For example, container **310** may comprise two intermediate members **302'**, **302''** interposed between lid **314** and base **312**. Such an embodiment is capable of housing three optical discs.

[0063] Figures 21-24 depict various views of an optical disc container **510** according to another embodiment of the invention. Container **510** comprises a hand-operated, translatable disc ejection mechanism described in detail below.

[0064] Figures 21A, 21B respectively depict top plan and isometric views of container **510** in a locked configuration. Container **510** comprises a shell **512** and an ejection member **520**. As shown best in Figures 22, shell **512** comprises an upper shell portion **512A** and a lower shell portion **512B** which define a space **560** therebetween. An optical disc **100** may be inserted into space **560** through a slot **550** formed in an arcuate edge portion **514** of shell **512**. In addition to arcuate edge portion **514**, shell **512** also comprises a pair of straight edge portions **513A**, **513B** shown best in Figures 21A, 21B.

[0065] As seen best in Figures 21A, 21B, an outward portion **527** of ejection member **520** comprises a hook **562**, a bore **564**, a finger **563**, and a channel **576** which may be shaped in a manner similar to hook **62**, bore **64**, finger **63** and channel **76** of container **10** (Figures 10-15, 18, 19, 20A, 20B) described above. Hook **562** may also function in a manner similar to hook **5** (Figures 2, 3) described above to facilitate connection of container **510** to a rod. Inward portion **529** of ejection member **520** comprises an upper lip **526** and a lower lip **528** which are vertically spaced apart from one another to form a slot **547** therebetween (Figure 22). When ejection member **520** is in its locked position (Figures 21A, 21B, 22 and 24A), inward portion **529** of ejection member **520** is encased in shell **512** and outward portion **527** projects outwardly from shell **512** at a perimeter edge thereof. When container **510** receives an optical disc **100** in space **560**, one edge portion (not shown) of optical disc **100** is received in slot **547** between upper lip **526** and lower lip **528**.

- 23 -

[0066] From its locked position (Figures 21A, 21B, 22 and 24A),  
ejection member **520** is inwardly translatable to an eject position (Figure  
24B). When a user translates ejection member **520** between its locked  
position (Figures 21A, 21B, 22 and 24A) and its eject position (Figure  
5 24B), ejection member **520** pushes on the edge of optical disc **100** to  
eject optical disc **100** from container **510** through slot **550**. Ejection  
member **520** is also outwardly translatable, such that when ejection  
member **520** is in its eject position, a user may push optical disc **100**  
inwardly into container **510** through slot **550** and, in doing so, translate  
10 ejection member **520** outwardly back to its locked position.

[0067] Container **510** also comprises an optional locking  
mechanism **533**. Locking mechanism **533** (best seen in Figure 23)  
includes retainer **530**, which is circumferentially slideable in a channel  
15 **516**. In the illustrated embodiment, locking mechanism **533** is located  
on perimeter edge **514** of shell **512** adjacent one edge of slot **550**.  
Retainer **530** comprises a user actuatable protrusion **532** and a  
deformable end portion **531**. Protrusion **532** projects outwardly through  
a slot **517** in perimeter edge **514** of shell **512**. A user may slide  
20 protrusion **532** circumferentially in slot **517** to slide retainer **530**  
circumferentially within channel **516**. In the illustrated embodiment,  
slot **517** comprises indents **517A**, **517B** at either end thereof and  
retainer **530** can be locked in a particular position by placing protrusion  
**532** into one of slots **517A**, **517B**. When protrusion **532** is locked in  
25 indent **517B**, deformable end portion **531** partially blocks slot **550**, such  
that an optical disc **100** housed in space **560** of container **510** is retained  
therein (i.e. ejection member **520** cannot translate from its locked  
position to its eject position to eject optical disc **100**). To access optical  
disc **100**, a user moves protrusion **532** toward indent **517A**, causing  
30 deformable end portion **531** of retainer **530** to be withdrawn from the  
front of slot **550**, such that optical disc **100** may be ejected  
therethrough.

[0068] As best seen in Figure 23, the upper side of lower shell  
35 portion **512B** of the illustrated embodiment comprises a dock **552B**  
located in the gap between its straight edges **513A** and **513B**. Dock  
**552B** may comprise guiding rails **553A** and **553B** which guide the  
inward and outward motion of ejection member **520** as it moves between

- 24 -

its locked configuration and its eject configuration. Dock **552B** may also comprise a channel **518B** which allows ejection member **520** to translate to its eject configuration while it is coupled to rod **9** (see Figure 24A, 24B). As also seen best in Figure 23, lower shell portion **512B** comprises a guiding rail **515A** which defines channel **516** for receiving retainer **530**. In the illustrated embodiment, lower shell portion **512B** also comprises an enclosure rail **515B** located on the opposing side of arcuate edge **514B** for housing a fixed retainer **540**. When an optical disc **100** is housed in container **510**, retainer **540** works together with retainer **530** to hold optical disc **100** in space **560** by exerting elastic force on the rim of optical disc **100**.

[0069] Figure 23 also shows that upper shell portion **512A** may comprise a dock **552A** having a channel **518A**. Those skilled in the art will appreciate that the lower side of upper shell portion **512A** may comprise features substantially similar to the features on the upper side of lower shell portion **512B** to form container **510**.

[0070] Figures 24A, 24B respectively depict the locked and eject configurations of container **510** (i.e. the locked and eject positions of ejection member **520**) to show how an optical disc **100** may be accessed while container **510** is coupled to rod **9**. In Figure 24A, container **510** is in a locked configuration with its hook **562** coupled to rod **9**. Protrusion **532** of retainer **530** is locked in indent **517B** causing deformable end portion **531** of retainer **530** to partially block slot **550**. In order to access optical disc **100**, a user may translate protrusion **532** towards indent **517A** at the other end of slot **517**, thereby withdrawing deformable end portion **531** of retainer **530** from the front of slot **550**. The user may then push container **510** toward rod **9**. As shown in Figure 24B, pushing container **510** towards rod **9** causes ejection member **520** to translate inwardly from its locked position to its eject position. As ejection member **520** translates inwardly, rod **9** may move into channel **518**. When ejection member **520** translates from its locked position to its eject position, it pushes optical disc **100** outwardly through slot **550**. As optical disc **100** is pushed past retainer **530**, deformable end portion **531** may be outwardly deformed by the wider parts of optical disc **100**. When the widest portion of optical disc **100** (i.e the diameter) passes retainer **530**, the elastic restoration force of deformable end portion **531** causes deformable end portion **531** to push

- 25 -

on the edges of optical disc **100**, thereby ejecting optical disc **100** outwardly through slot **550** as retainer **530** returns to its non-deformed state.

5 **[0071]** As discussed above, locking mechanism **533** is optional. In alternative embodiments, container **510** comprises different types of retaining mechanisms (i.e. other than retainers **530**, **540**) for holding an optical disc **100** by its rim.

10 **[0072]** As will be apparent to those skilled in the art in the light of the foregoing disclosure, many alterations and modifications are possible in the practice of this invention without departing from the spirit or scope thereof. For example:

- 15 • Figure 25 depicts a container **610** according to another alternative embodiment of the invention. In Figure 25, container **610** is in a partially open configuration. An optical disc **100** may be housed in container **610** in a space **613** between base **612** and lid **614**. As with the previously described embodiments, base **612** is pivotally coupled to lid **614** at pivot joint **616**, which allows lid **614** to pivot relative to base **612** about a pivot axis that is substantially orthogonal to the page. Pivot joint **616** of container **610** may generally be any type of pivot joint. Container **610** comprises other features similar to those of container **1** (Figure 2) and container **10** (Figures 10-15). However, hook **662** of  
20 container **610** is formed from a separate hook member **661** which extends outwardly from at least one of base **612** and lid **614**. Preferably, but not necessarily, hook member **661** may be coupled to pivot joint **616** such that it may pivot about the pivot axis with respect to base **612** and/or lid **614**.
- 25 • Containers **10**, **210**, **310**, **510**, **610** respectively comprise hooks **62**, **262**, **362**, **562**, **662**. Accordingly, they may be coupled to rods (not shown) in a manner similar to container **1** (Figure 3). As such, containers **10**, **210**, **310**, **510**, **610** may be used together with any of the storage and transport apparatus depicted  
30 in Figure 4-9. In general, containers **10**, **210**, **310**, **510**, **610** may be used together with any storage and transport apparatus comprising one or more rods to which the containers may be coupled.

- 26 -

- Pivot joint **16** depicted in Figure 18 and the other illustrated embodiments represents only one possible type of pivot joint. Those skilled in the art will appreciate that there are a wide variety of pivot joints that could provide the same functionality as that of the illustrated embodiments. The invention should be understood to include any pivot joint which allows pivotal motion of lid **14** with respect to base **12**. Preferably, such pivot joints comprise a bore within their perimeters and the channel **76** of hook **62** terminates in this bore (Figure 19).
  - In the illustrated embodiments, hook **62** is located in a corner of container **10** and comprises a channel **76** that terminates at semi-circular bore **64**. Bore **64** is formed by an inner surface of semi-annular base member **70** of pivotal joint **16**. In alternative embodiments, hook **62** may be located in different parts of container **10**. For example, hook **62** may be formed in a different corner or on a side of container **10**.
  - Pivot joint **16** is described and depicted (see Figure 18) as having certain components in lid **14** (i.e. semi-annular lid member **66**, flange **68**, and bore **77**) and other components in base **12** (i.e. semi-annular base member **70**, groove **72**, notch **74** and bore **64**). Those skilled in the art will appreciate that a pivot joint may also be formed by interchanging the joint components on lid **14** and the joint components on base **12**.
  - Bore **64** of hook **62** and pivot joint **16** are described and depicted as being semi-circular in shape. In alternative embodiments, the interior surface of bore **64** may have other shapes. For example, the interior surface of bore **64** may be shaped to allow coupling of hook **62** to rods which have a different shape.
- 30 **[0073]** Accordingly, the scope of the invention is to be construed in accordance with the substance defined by the following claims.

- 27 -

## WHAT IS CLAIMED IS:

1. A container for housing optical discs, the container comprising:  
a base;  
5 a lid coupled to the base by a pivot joint for releasably housing an optical disc between the base and the lid, the pivot joint permitting pivotal motion of the lid relative to the base about a pivot axis that is substantially orthogonal to a plane of the disc housed between the base and the lid; and  
10 a hook for coupling the container to a rod.
2. A container according to claim 1 wherein the hook is formed by a perimeter edge of at least one of the base and the lid.
- 15 3. A container according to claim 1 wherein the hook is formed on a perimeter of both the base and the lid.
4. A container according to claim any one of claims 2 to 3 wherein the hook comprises a finger that extends around a portion of the  
20 pivot joint.
5. A container according to claim 4 wherein an edge of the finger defines at least a portion of an inwardly extending channel which leads towards the pivot joint and terminates in a bore located  
25 within the pivot joint.
6. A container according to claim 5 wherein the bore comprises an edge that is semi-circular in shape.
- 30 7. A container according to claim 5 wherein a width of the bore is greater than a width of the channel immediately outside of the bore.

- 28 -

8. A container according to any one of claims 1 to 3 wherein the pivot joint comprises a semi-annular lid member which extends from the lid in a direction parallel to the pivot axis and a semi-annular base member that extends from the base in a direction parallel to the pivot axis, the semi-annular lid and base members slidably coupled to one another to enable pivotal movement of the lid relative to the base about the pivot axis.
9. A container according to claim 8 wherein the pivot joint comprises a bore through a center thereof, an edge of the bore formed by one of: the semi-annular base member and the semi-annular lid member.
10. A container according to claim 9 wherein the edge of the bore is semi-circular in shape.
11. A container according to claim 10 wherein the edge of the bore is formed by the semi-annular base member and wherein the base comprises a semi-annular groove which receives the semi-annular lid member.
12. A container according to claim 11 wherein the semi-annular groove comprises a notch on a side thereof, the semi-annular lid member comprises a flange on a side thereof, and the flange is received in the notch for preventing the lid from inadvertently coming apart from the base.
13. A container according to claim 10 wherein the edge of the bore is formed by the semi-annular lid member and wherein the lid comprises a semi-annular groove which receives the semi-annular base member.
14. A container according to claim 13 wherein the semi-annular groove comprises a notch on a side thereof, the semi-annular base member comprises a flange on a side thereof, and the flange is received in the notch for preventing the lid from inadvertently coming apart from the base.

- 29 -

15. A container according to any one of claims 9 to 10 wherein the edge of the bore comprises an opening that leads to a curved channel, the channel extending outwardly towards a perimeter edge of the container.
- 5
16. A container according to any one of claims 9 to 14 wherein the hook comprises a finger that extends around a portion of the pivot joint.
- 10
17. A container according to claim 16 wherein an edge of the finger defines at least a portion of an inwardly extending channel which leads towards the pivot joint and terminates in the bore in the center of the pivot joint.
- 15
18. A container according to claim 17 wherein a width of the bore is greater than a width of the channel immediately outside of the bore.
- 20
19. A container according to any one of claims 1 to 18 comprising a latch mechanism for maintaining the lid in a closed pivotal orientation with respect to the base.
- 20.
20. A container according to claim 19 wherein the latch mechanism comprises one or more protrusions on the lid which project into one or more corresponding indentations on the base when the lid is in the closed pivotal orientation.
- 25
21. A container according to claim 19 wherein the latch mechanism comprises one or more protrusions on the base which project into one or more corresponding indentations on the lid when the lid is in the closed pivotal orientation.
- 30
22. A container according to any one of claims 1 to 21 comprising a pivot joint locking mechanism for preventing pivotal movement of the lid with respect to the base.
- 35

- 30 -

23. A container according to claim 22, wherein the pivot joint locking mechanism comprises a shaft, which is slideable to a locking position where a portion of the shaft projects into the pivot joint to prevent pivotal movement of the lid with respect to the base.
- 5
24. A container according to any one of claims 1 to 23 wherein the perimeter of the base and the perimeter of the lid each comprise at least two straight edge portions and at least one arcuate edge portion.
- 10
25. A container according to claim 24 wherein the two straight edge portions are aligned substantially orthogonally to one another.
26. A container according to any one of claims 1 to 25 wherein the base comprises a retainer for releasably holding the optical disc against a surface thereof.
- 15
27. A container according to claim 26 wherein the retainer comprises a plurality of deformable members which project through a hole in the optical disc and which provide pressure against an edge of the hole to hold the optical disc against the surface of the base.
- 20
28. A container according to claim 27 wherein the retainer comprises one or more deformable members which provide pressure against an outer circumferential rim of the optical disc to hold the optical disc against the surface of the base.
- 25
29. A container according to claim 1 wherein the hook is formed by a hook member which is coupled to at least one of the base and the lid.
- 30
30. A container according to claim 29 wherein the hook member is coupled to the pivot joint for pivotal motion with respect to at least one of the lid and the base.
- 35

- 31 -

31. A container for housing substantially planar optical discs, the container comprising:  
a base having a base finger on its perimeter;  
a lid pivotally coupled to the base by a pivot joint for housing an optical disc between the base and the lid, the lid having a lid finger on its perimeter;  
wherein the base finger and lid finger form a hook and wherein the pivot joint permits pivotal motion of the lid relative to the base about a pivot axis that is substantially orthogonal to a plane of the disc.
32. A container according to claim 31 wherein the base finger defines a curved base channel that extends inwardly toward an interior of the base and the lid finger defines a curved lid channel that extends inwardly toward an interior of the lid.
33. A container according to claim 32 wherein the inwardmost edge of the lid channel and the inwardmost edge of the base channel form a bore located within the pivot joint.
34. An apparatus for housing optical disc containers, the apparatus comprising a rod and at least one container, each container comprising:  
a base;  
a lid coupled to the base by a pivot joint for releasably housing an optical disc between the base and the lid, the pivot joint permitting pivotal motion of the lid relative to the base about a pivot axis that is substantially orthogonal to a plane of the disc housed between the base and the lid;  
a hook for coupling the container to the rod.
35. A container for housing an optical disc, the container comprising a hook for coupling the container to a rod.

- 32 -

36. A container according to claim 35 comprising:  
a shell shaped to define a space in an interior thereof and  
having a slot in a peripheral surface thereof for insertion and  
removal of an optical disc from the space;
- 5 an ejection member moveably coupled to the shell for  
moving between an inward position wherein a first portion of the  
ejection member is located in the space and an outward position  
wherein the first portion of the ejection member is located  
outwardly of the space.
- 10 37. A container according to claim 36 wherein movement of the  
ejection member from the outward position to the inward position  
causes the first portion of the ejection member to abut against an  
optical disc located in the space and to at least partially eject the  
optical disc through the slot.
- 15 38. A container according to any one of claims 36 to 37 wherein the  
hook is formed on a second portion of the ejection member.
- 20 39. A container according to any one of claims 36 to 38 wherein the  
shell comprises a dock for guiding the ejection member between  
the inward and outward positions.
- 25 40. A container according to claim 39 wherein the dock comprises  
guide rails for slidably guiding the ejection member between the  
outward position and the inward position.
- 30 41. A container according to claim 39 wherein the dock comprises a  
channel in an outward end thereof for receiving a rod to which the  
container is coupled.
- 35 42. A container according to any one of claims claim 37 to 41  
comprising one or more retainers for applying pressure against a  
rim of the optical disc when it is located in the space.
43. A container according to claim 37 comprising a locking  
mechanism for preventing the optical disc located in the space  
from inadvertently ejecting.

- 33 -

44. A container according to claim 43 wherein the locking mechanism comprises a retainer, which is moveable to a locking position where a portion of the retainer partially blocks the slot.
- 5 45. An apparatus for storing or transporting one or more optical discs, the apparatus comprising a rod and one or more containers according to claim 1, 31, 34 or 35, wherein the hook of the one or more optical disc containers is mountable to the rod.

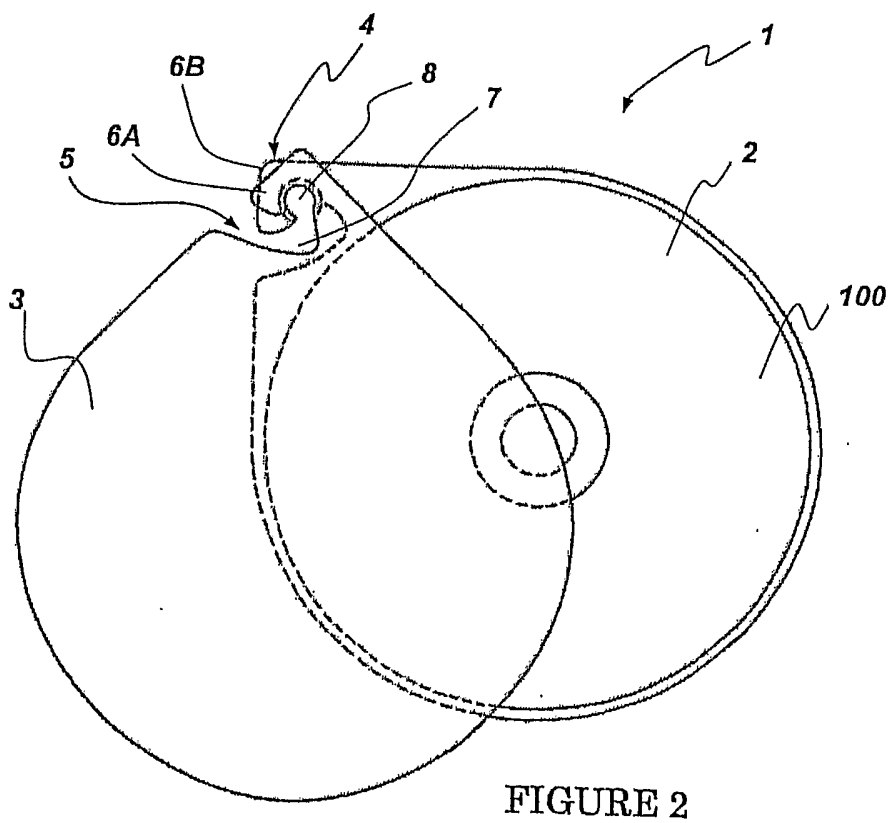
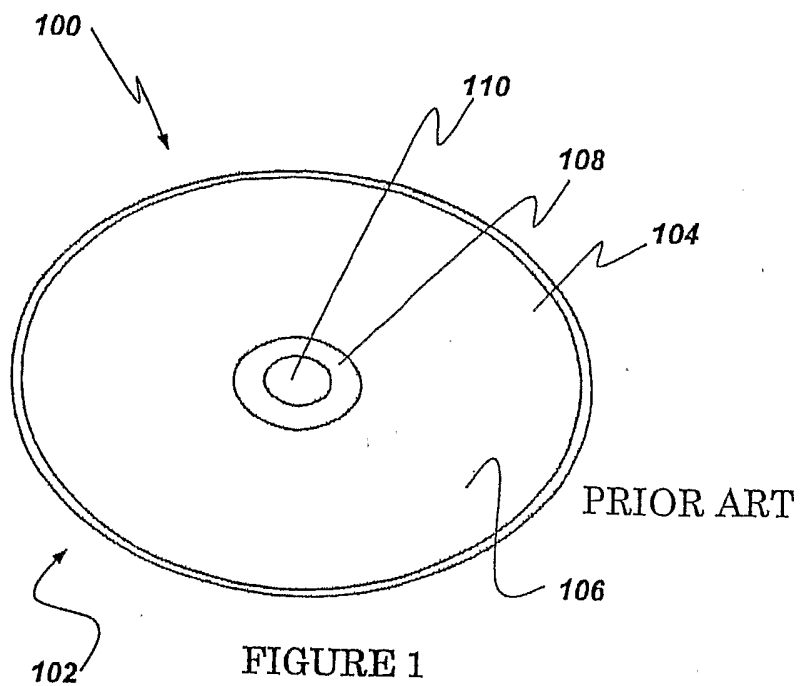

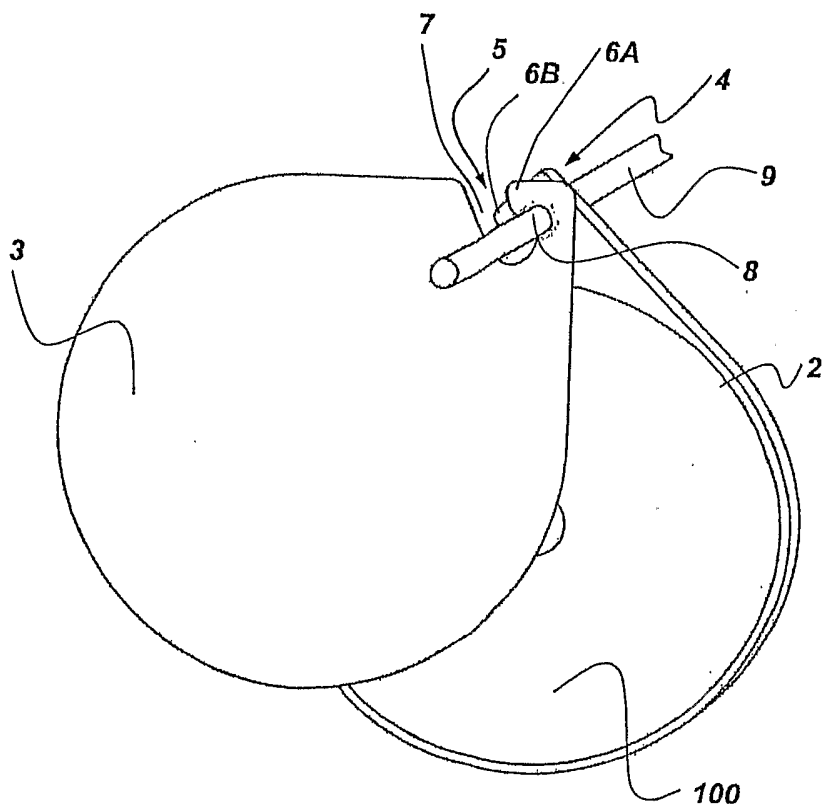

FIGURE 3

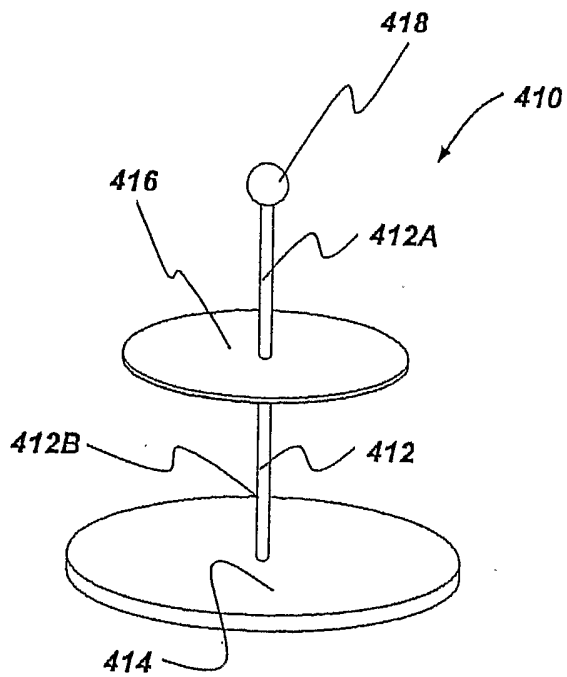

FIGURE 4

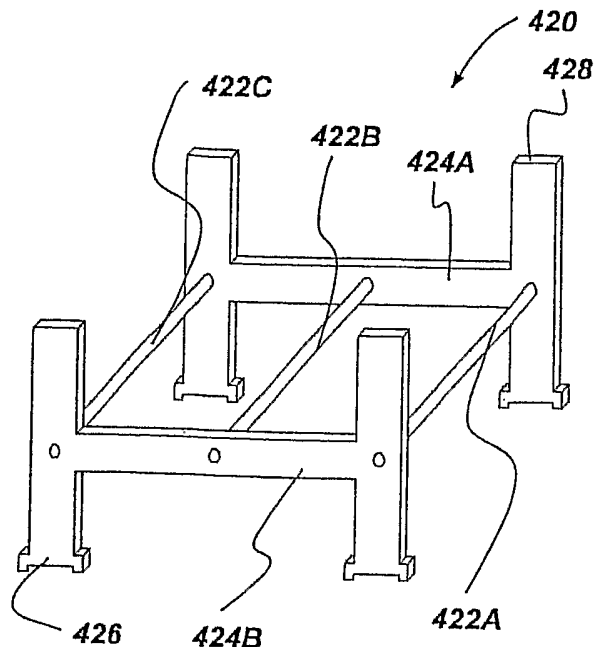

FIGURE 5

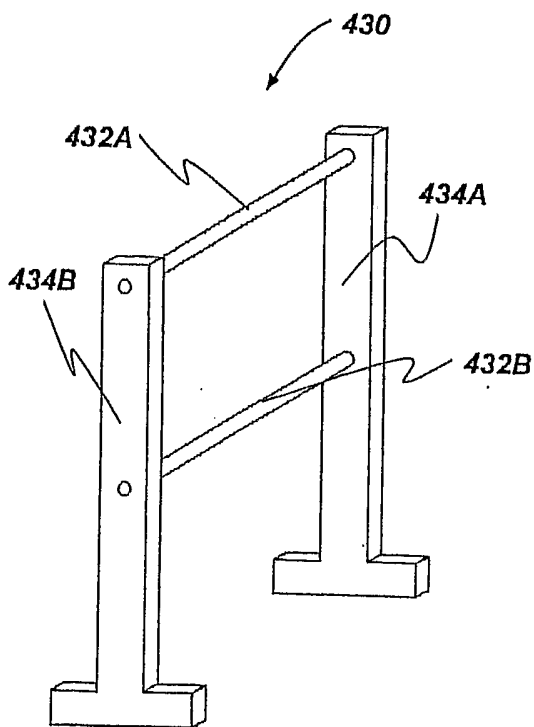

FIGURE 6

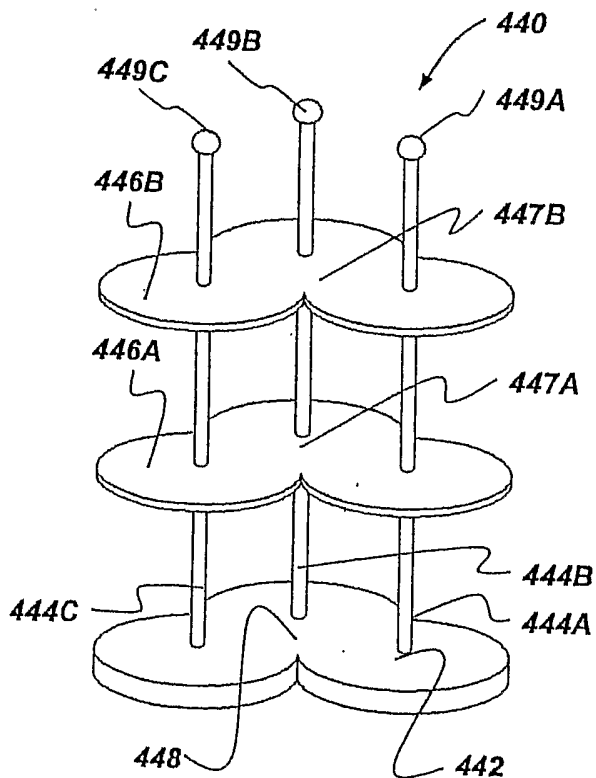

FIGURE 7

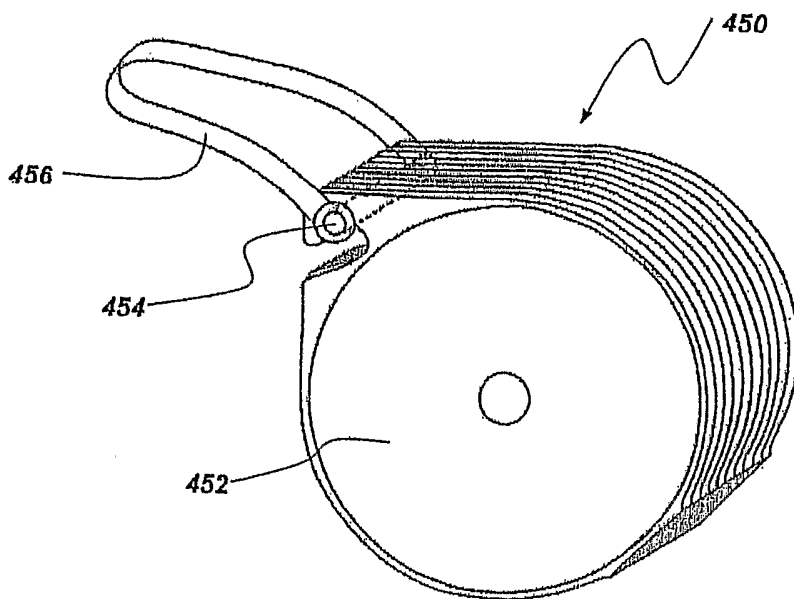

FIGURE 8

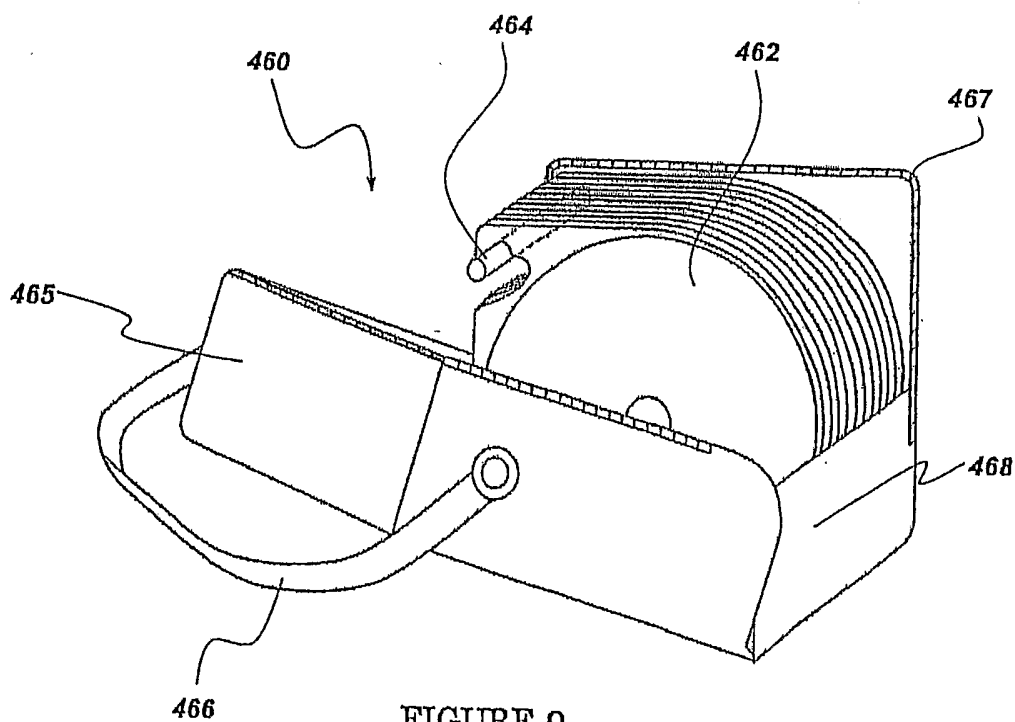

FIGURE 9

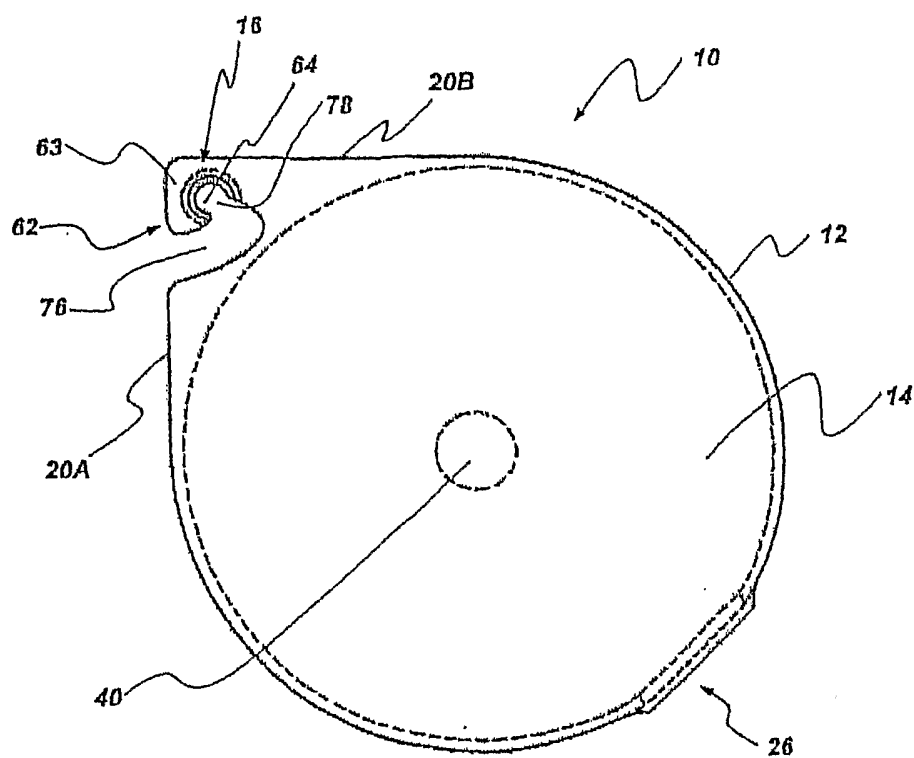

FIGURE 10

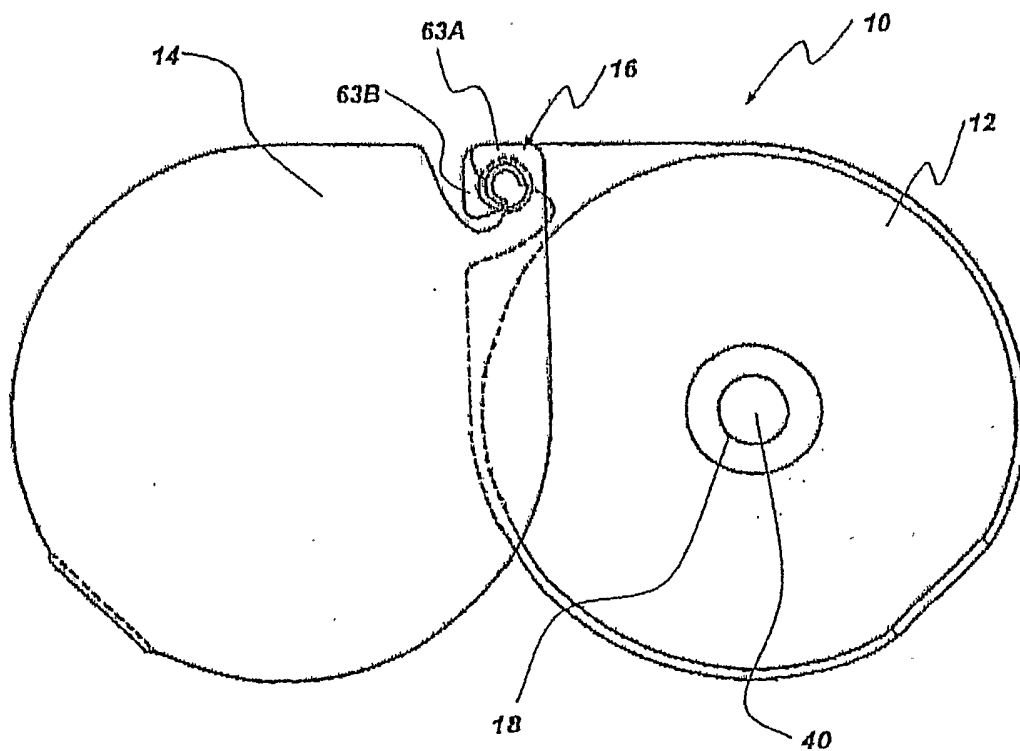

FIGURE 11

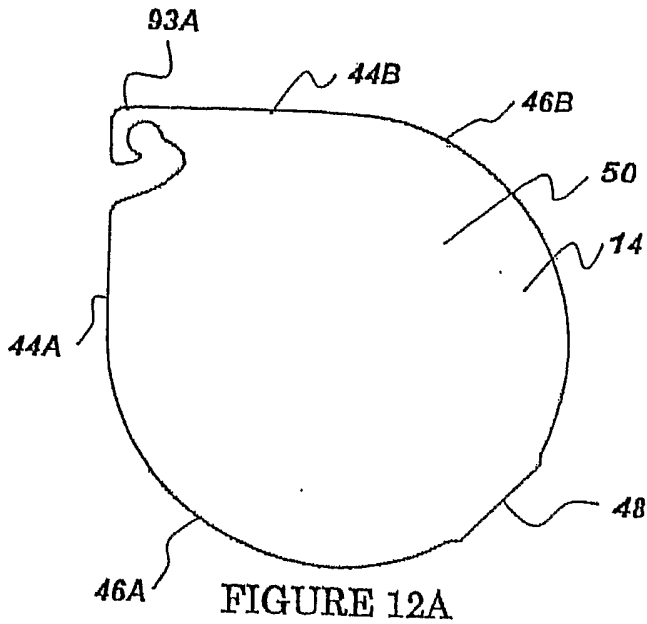

FIGURE 12A

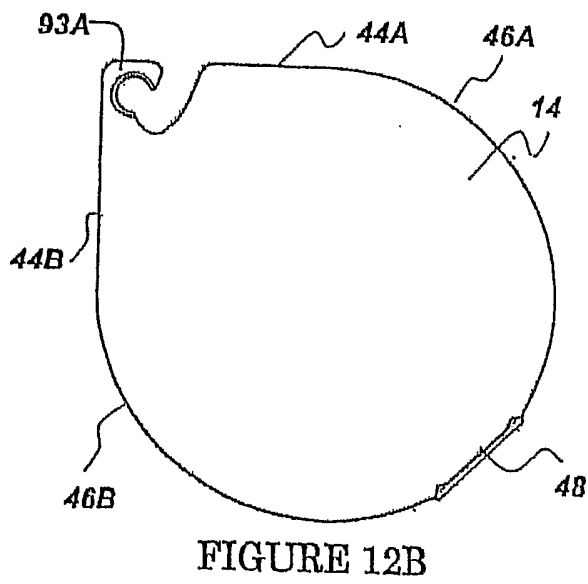

FIGURE 12B

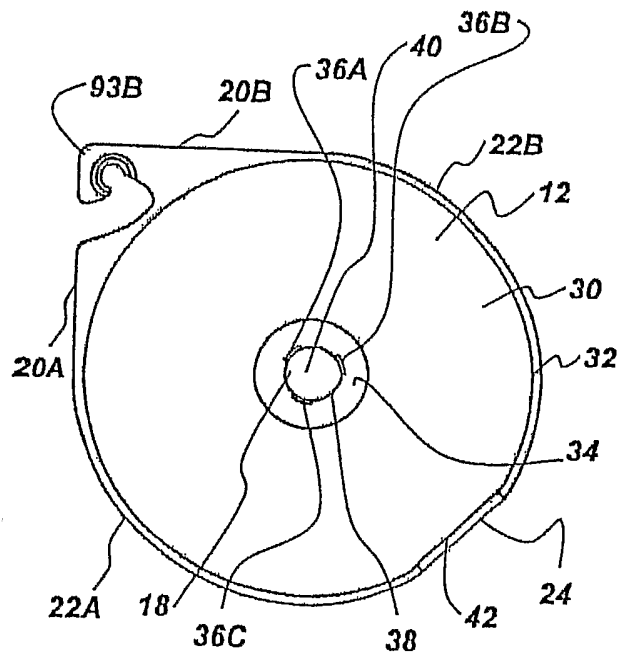

FIGURE 13A

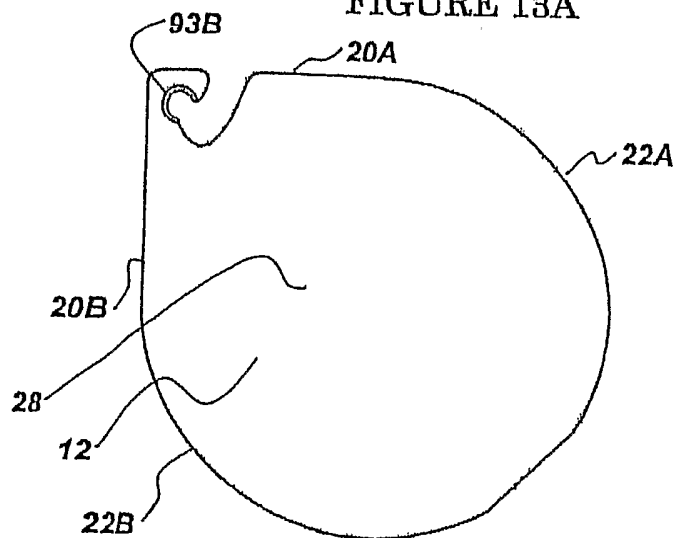

FIGURE 13B

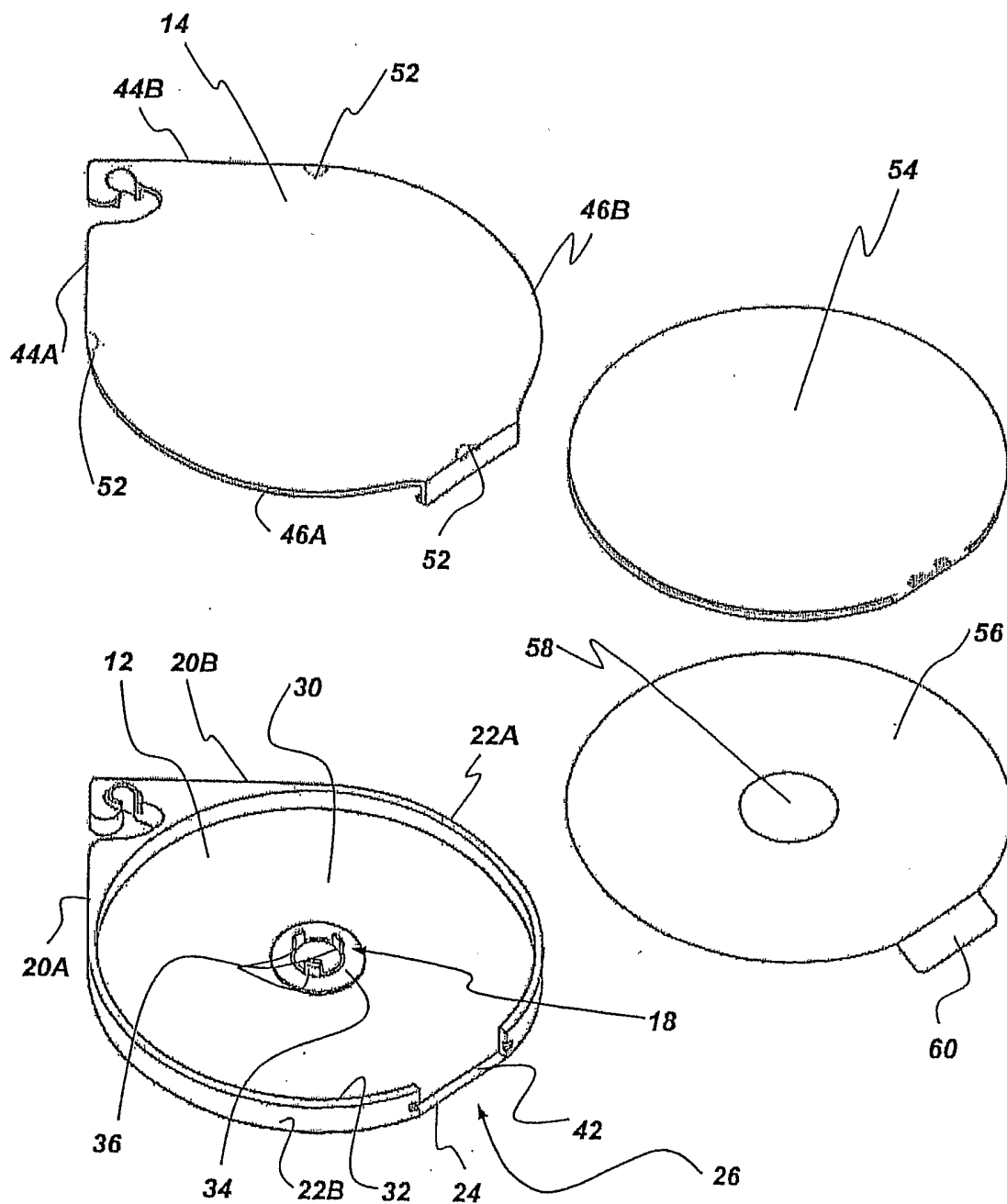

FIGURE 14

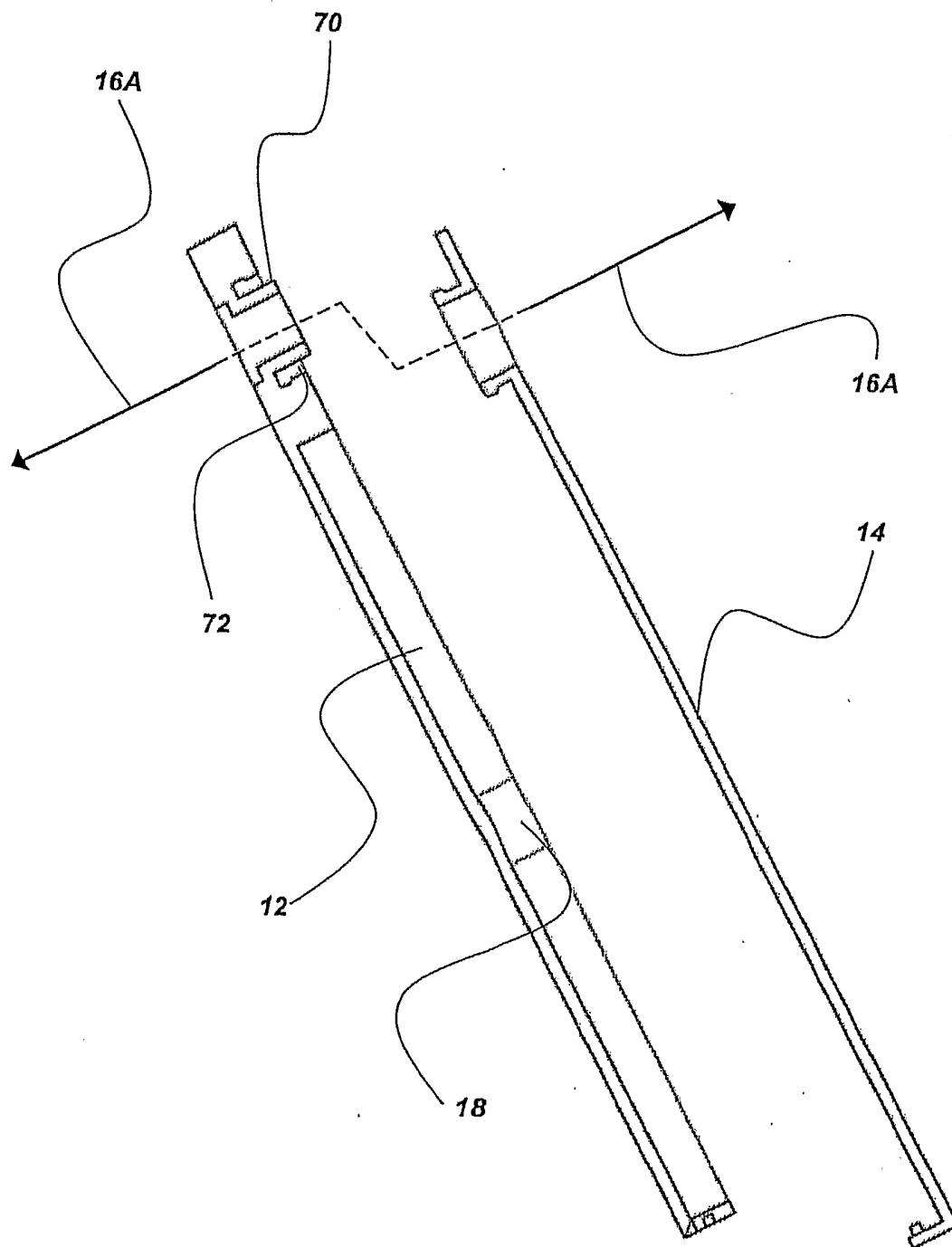

FIGURE 15

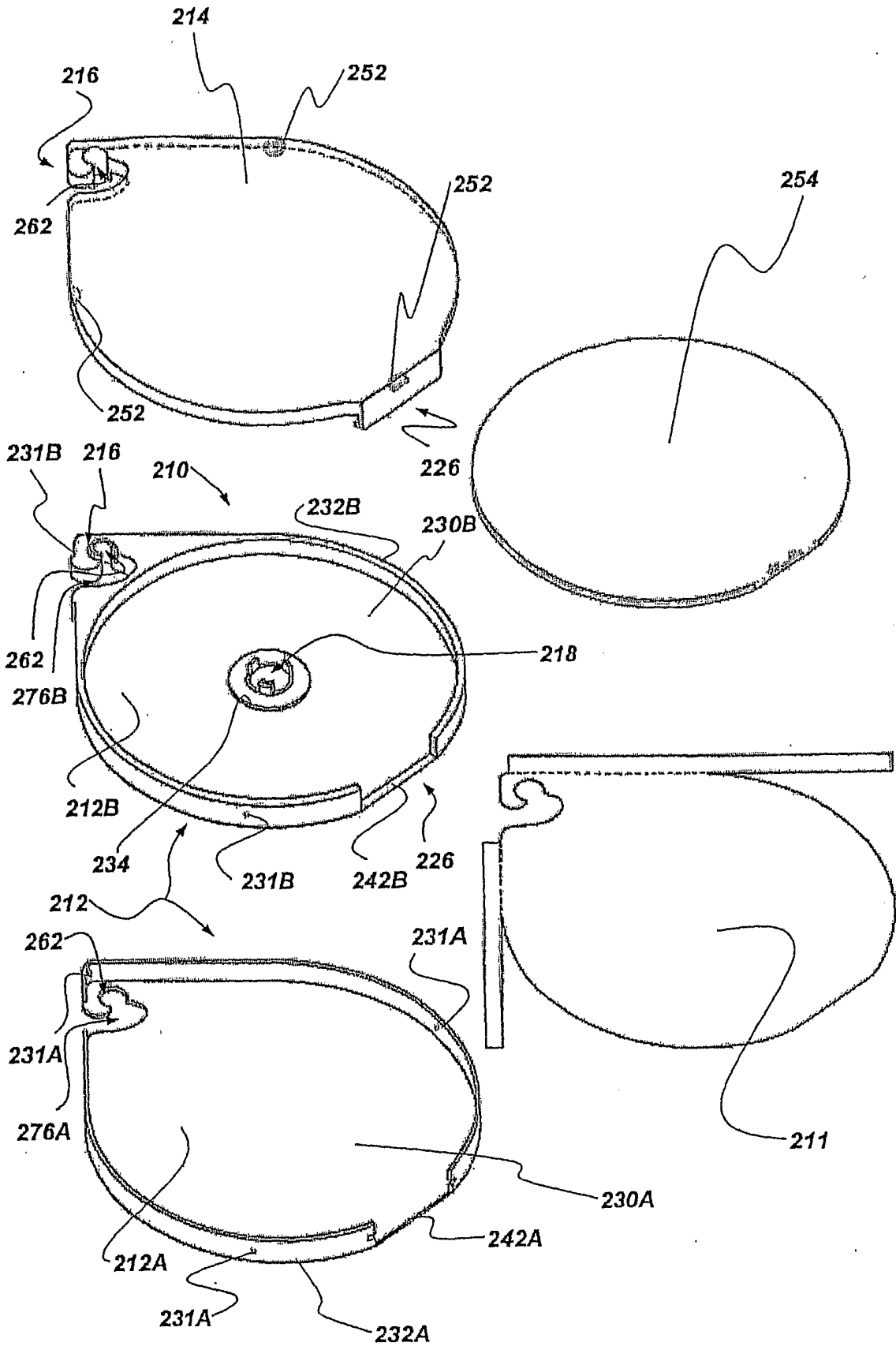

FIGURE 16

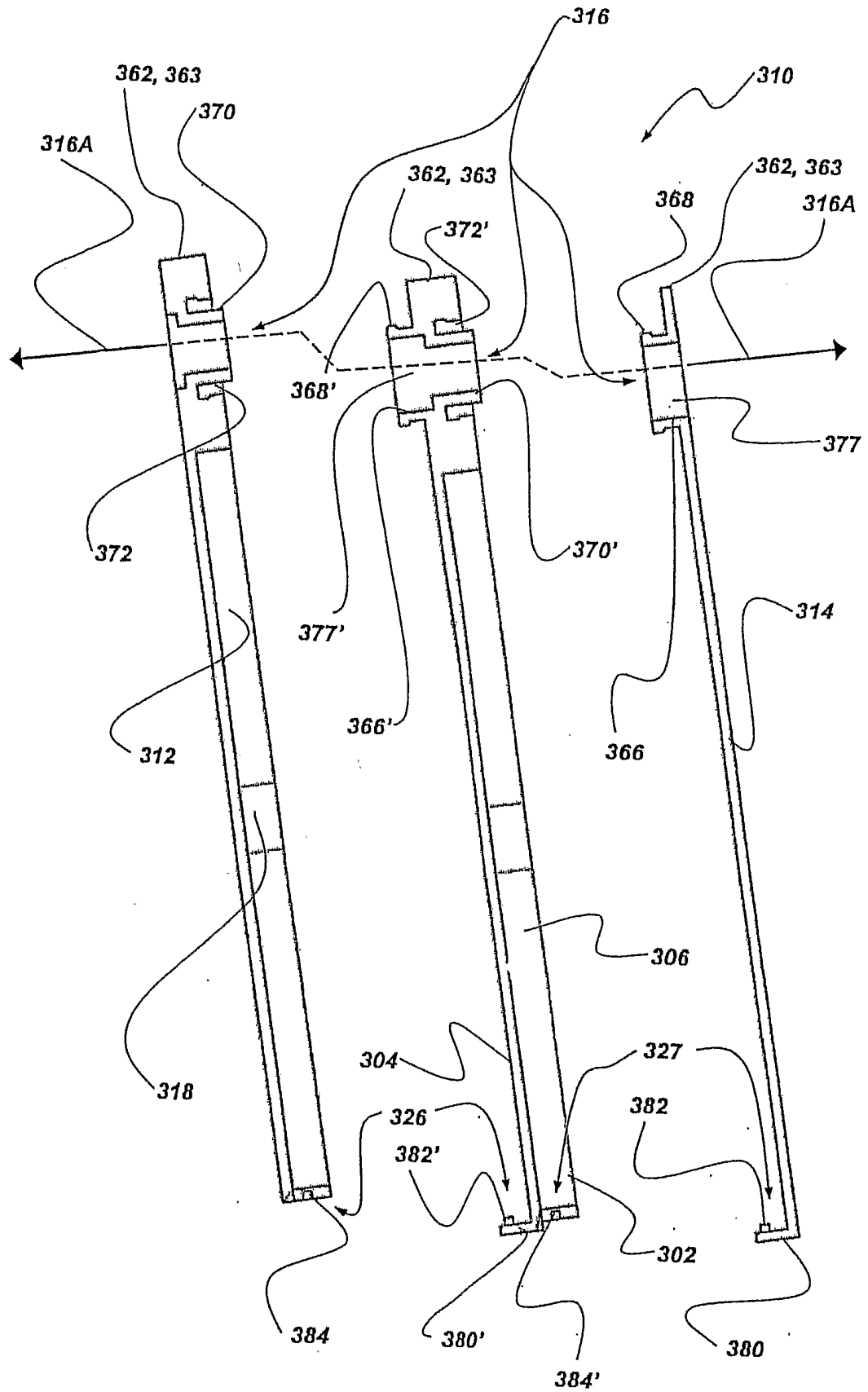

FIGURE 17

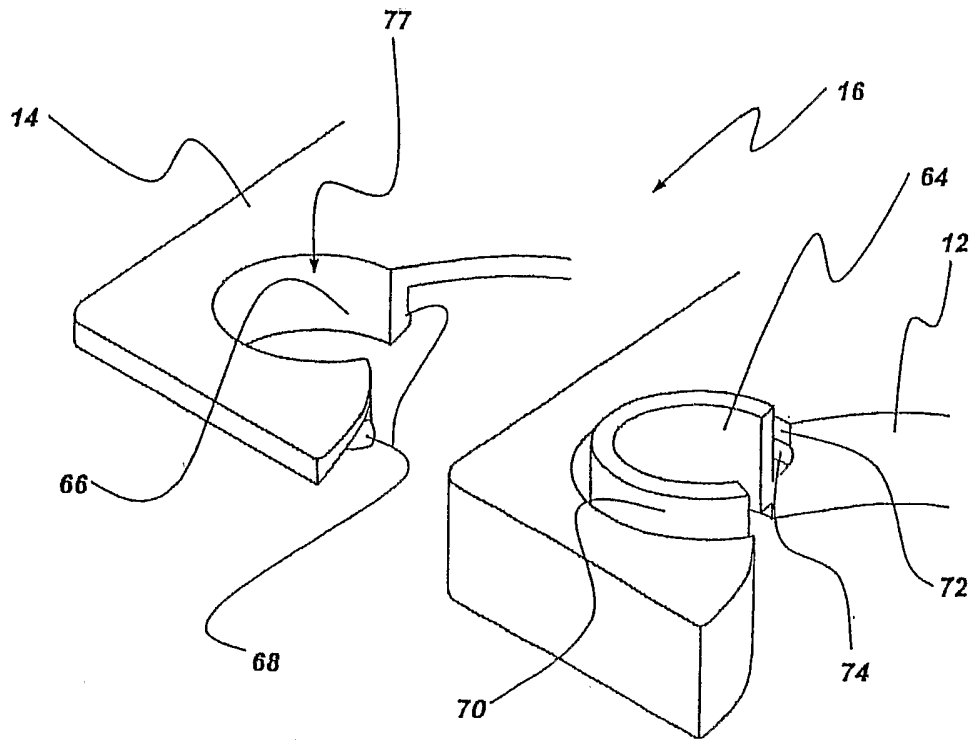

FIGURE 18

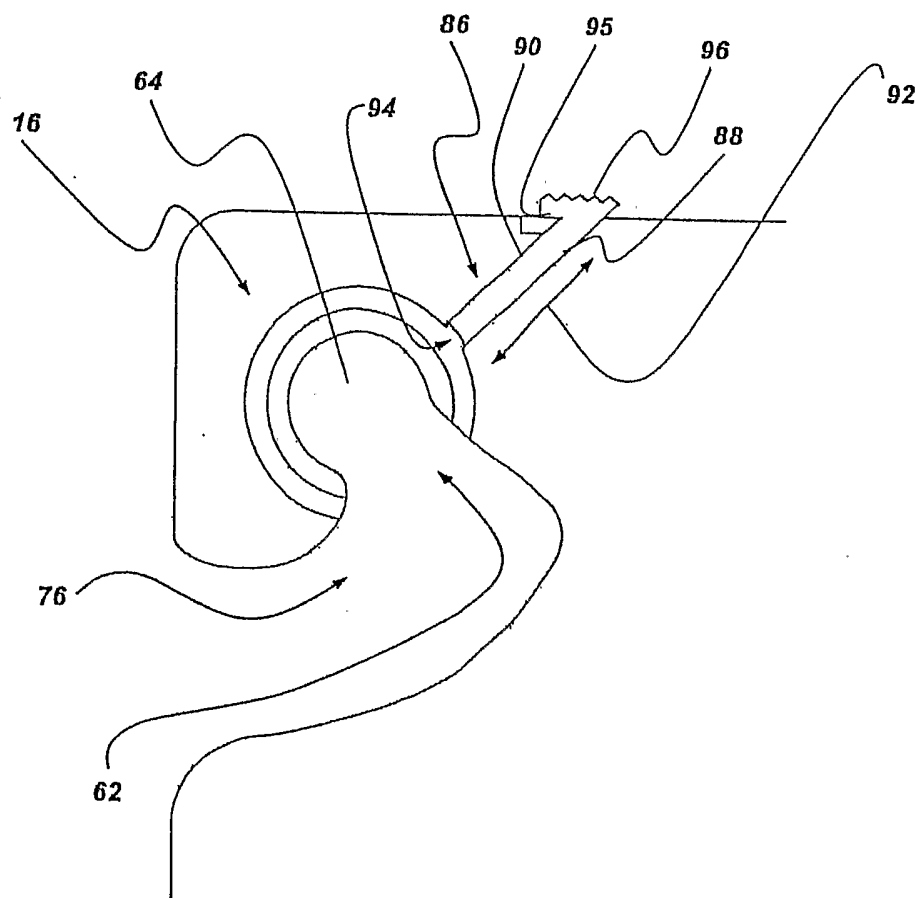

FIGURE 19

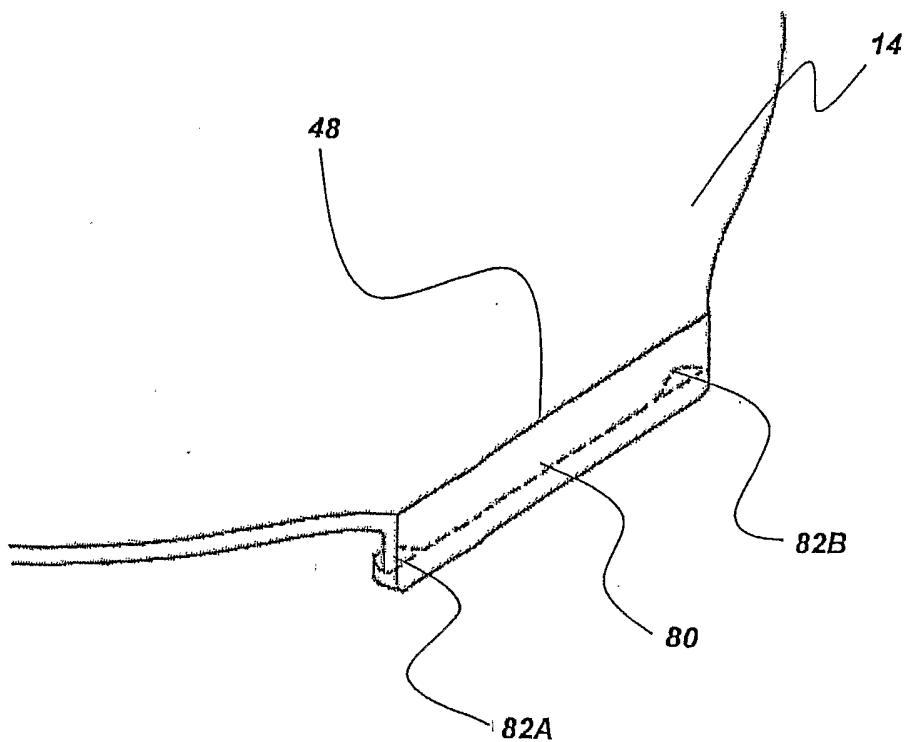

FIGURE 20A

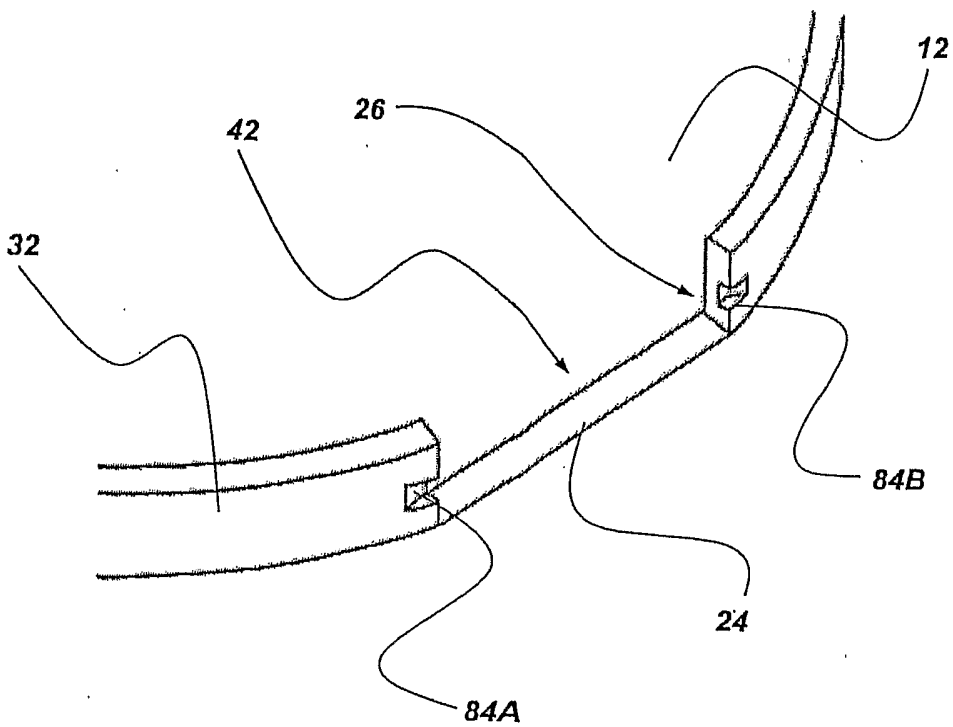

FIGURE 20B

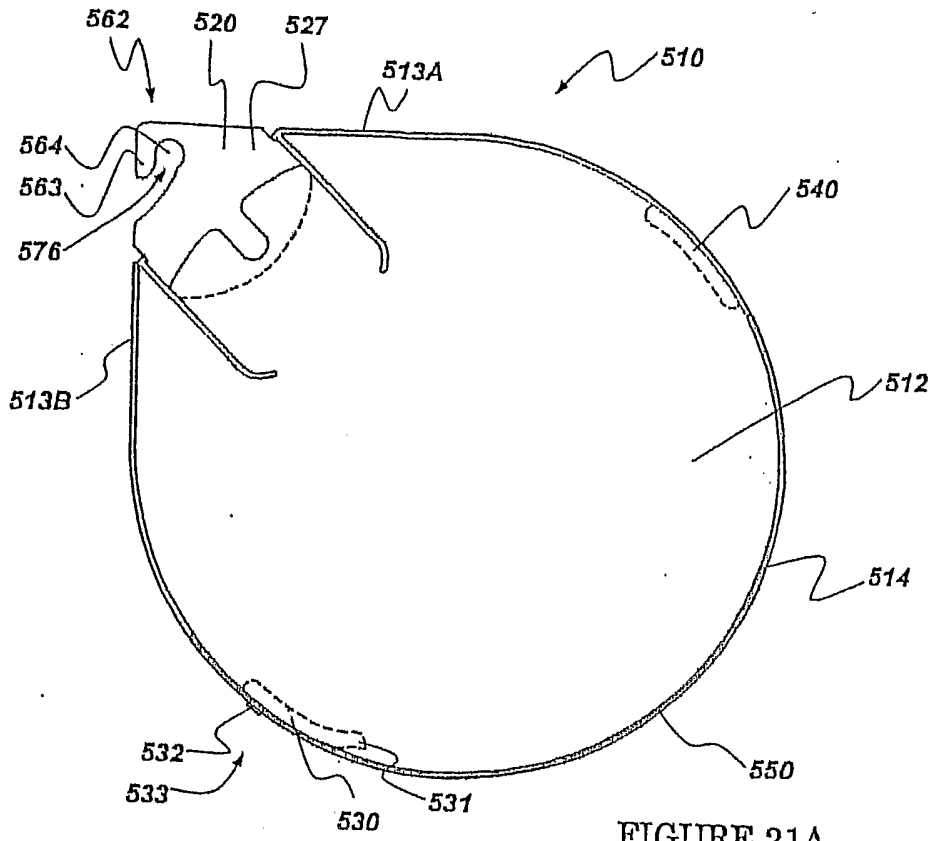

FIGURE 21A

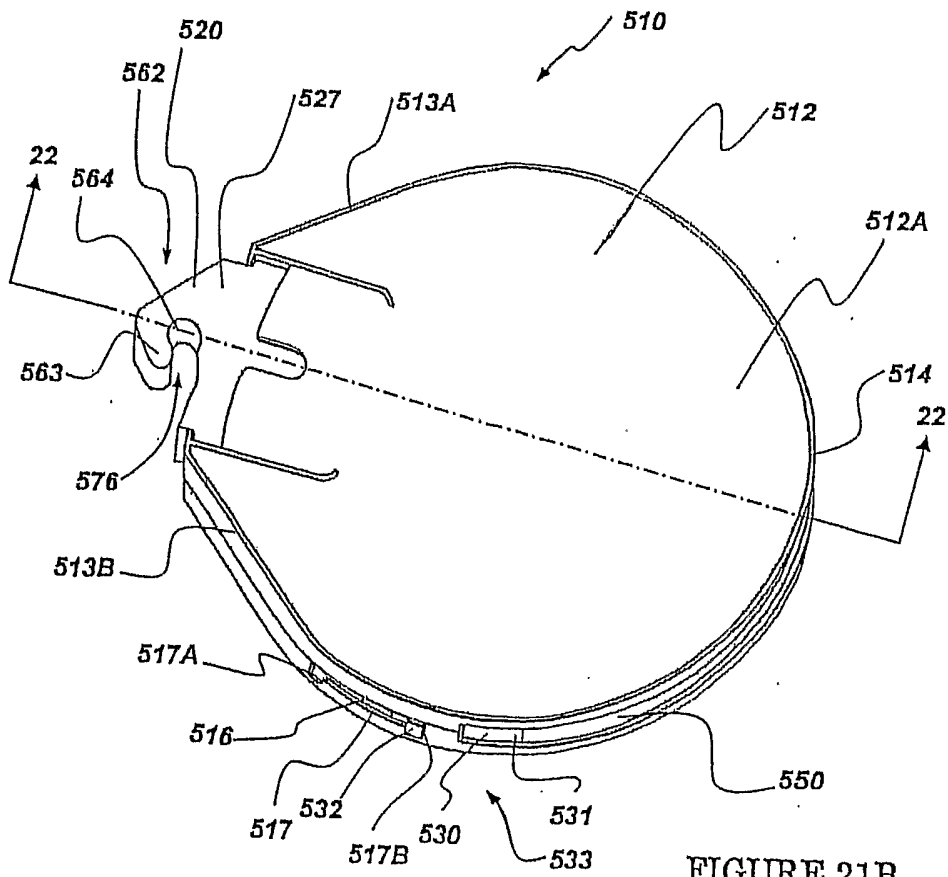

FIGURE 21B

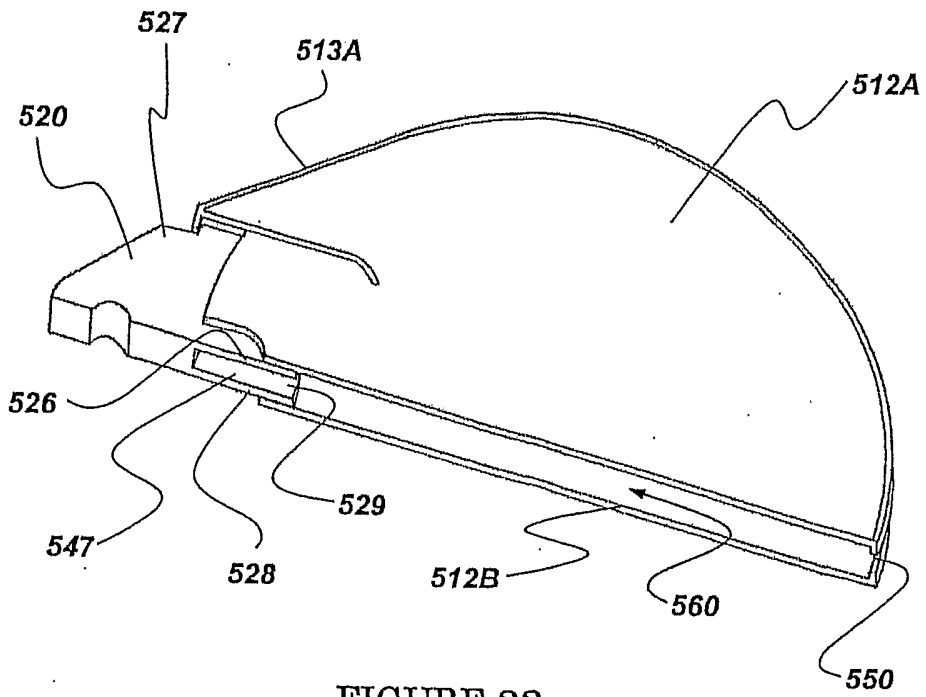

FIGURE 22

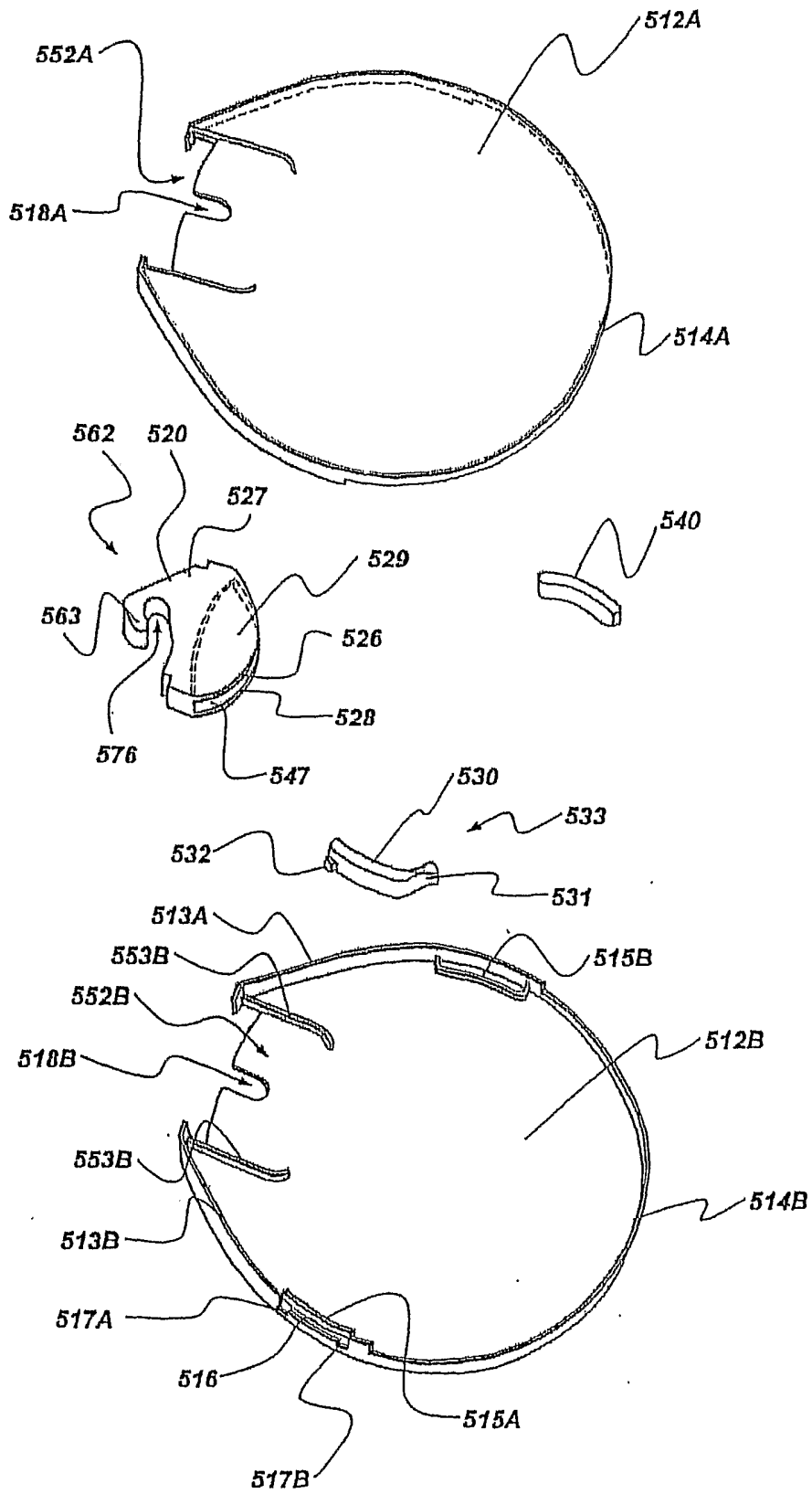
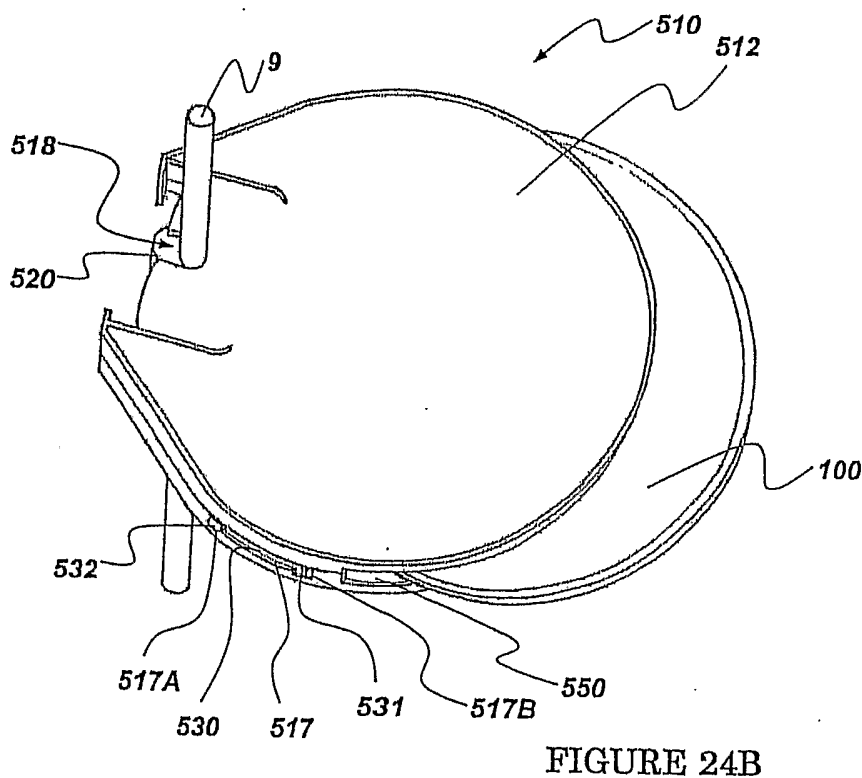
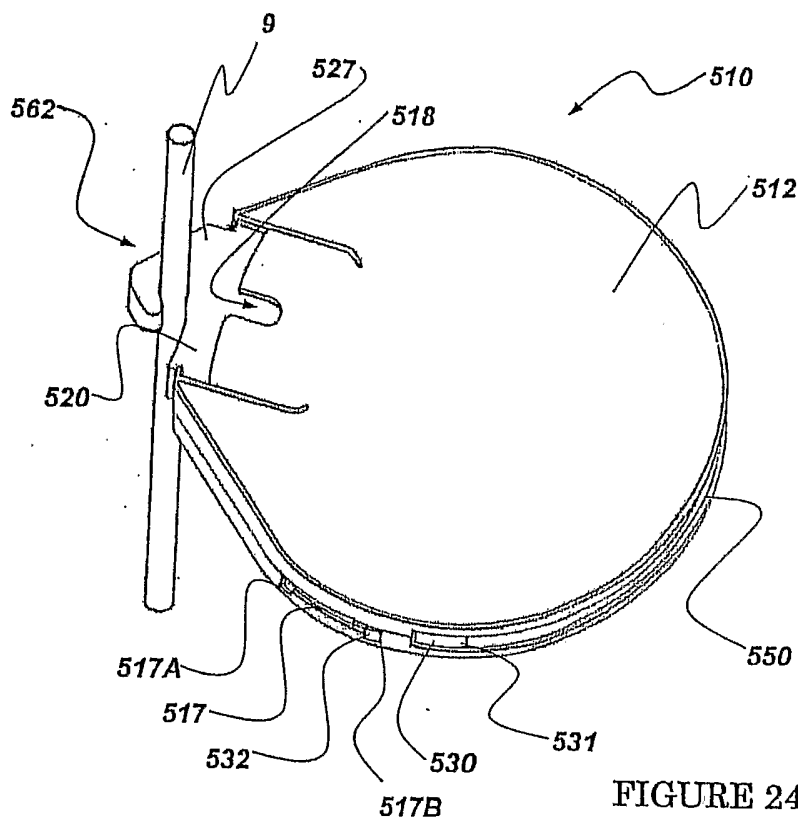

FIGURE 23



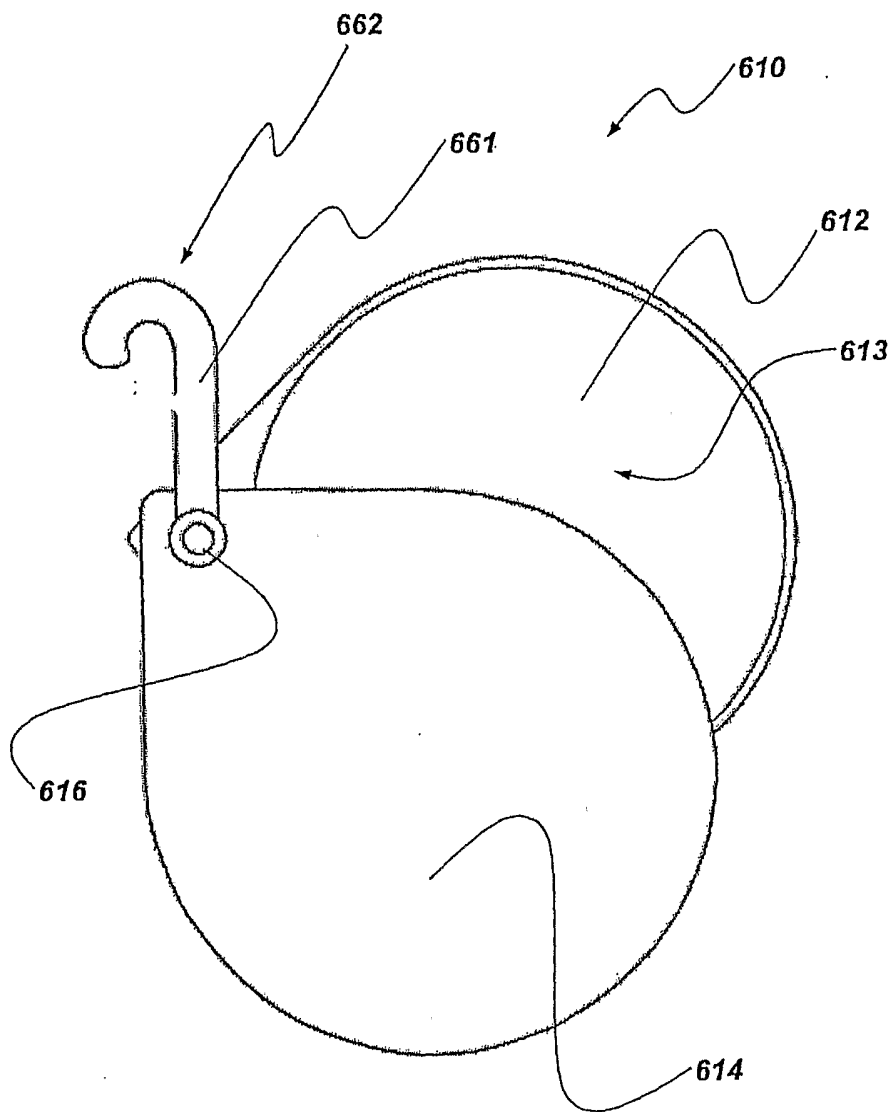

FIGURE 25

## INTERNATIONAL SEARCH REPORT

International application No.  
PCT/CA2004/001521

A. CLASSIFICATION OF SUBJECT MATTER IPC7 B65D 85/57, B65D 43/18		
B. FIELDS SEARCHED		
Minimum documentation searched (classification system followed by classification symbols) IPC7 B65D		
Documentation searched other than minimum documentation to the extent that such documents are included in the fields searched		
Electronic data base consulted during the international search (name of data base, and, where practicable, search terms used) Delphion, Espacenet, USPTO, Canadian Patent Database - classification search with keywords (ex. pivot*, hook*)		
C. DOCUMENTS CONSIDERED TO BE RELEVANT		
Category*	Citation of document, with indication, where appropriate, of the relevant passages	Relevant to claim No.
X	US 4771890 A (Hofland, R. M. et al.) 20 September 1988 (20.09.1988), Figure 1;	35
Y	Column 2, lines 9-20; Column 3, lines 26-28; Column 3, lines 51-56.	1, 2, 19, 20, 26-28, 36, 37, 42, 45
Y	US 5417323 A (Presnick, M.C.) 23 May 1995 (23.05.1995), Column 2, lines 32-39; Column 3, lines 29-41.	1, 2, 19, 20, 26-29, 34, 45
Y	US 2002/0195409 A1 (Ku, C. C.) 26 December 2002 (26.12.2002), Figure 7; Figure 8B.	29, 34, 45
Y	US 5590768 A (Hilton, L.) 7 January 1997 (07.01.1997), Abstract; Figure 1; Figure 2; Figure 7.	36, 37, 42
Further documents are listed in the continuation of Box C. Patent family members are listed in annex.		
* Special categories of cited documents :	"T"	later document published after the international filing date or priority date and not in conflict with the application but cited to understand the principle or theory underlying the invention
"A" document defining the general state of the art which is not considered to be of particular relevance	"X"	document of particular relevance; the claimed invention cannot be considered novel or cannot be considered to involve an inventive step when the document is taken alone
"E" earlier application or patent but published on or after the international filing date	"Y"	document of particular relevance; the claimed invention cannot be considered to involve an inventive step when the document is combined with one or more other such documents, such combination being obvious to a person skilled in the art
"L" document which may throw doubts on priority claim(s) or which is cited to establish the publication date of another citation or other special reason (as specified)	"&"	document member of the same patent family
"O" document referring to an oral disclosure, use, exhibition or other means		
"P" document published prior to the international filing date but later than the priority date claimed		
Date of the actual completion of the international-type search 31 October 2004 (31-10-2004)	Date of mailing of the international-type search report 14 January 2005 (14-01-2005)	
Name and mailing address of the ISA/ Commissioner of Patents Canadian Patent Office - PCT Ottawa/Gatineau K1A 0C9 Facsimile No. 1-819-953-9358	Authorized officer  Derek Jackson (819) 934-4259	

**INTERNATIONAL SEARCH REPORT**  
Information on patent family members

International application No.  
PCT/CA2004/001521

Patent Document Cited in Search Report	Publication Date	Patent Family Member(s)	Publication Date
US4771890	20-09-1988	DE3782096D D1	12-11-1992
		DE3782096T T2	15-04-1993
		EP0252226 A1	13-01-1988
		JP62271271 A	25-11-1987
		JP62291770 A	18-12-1987
US5417323	23-05-1995	None	
US2002/0195409 A1	26-12-2002	CN1145968B B	14-04-2004
		EP1271515 A2	02-01-2003
		US6644482 B2	11-11-2003
US5590768	07-01-1997	AU1825297 A	01-08-1997
		WO9725260 A1	17-07-1997