

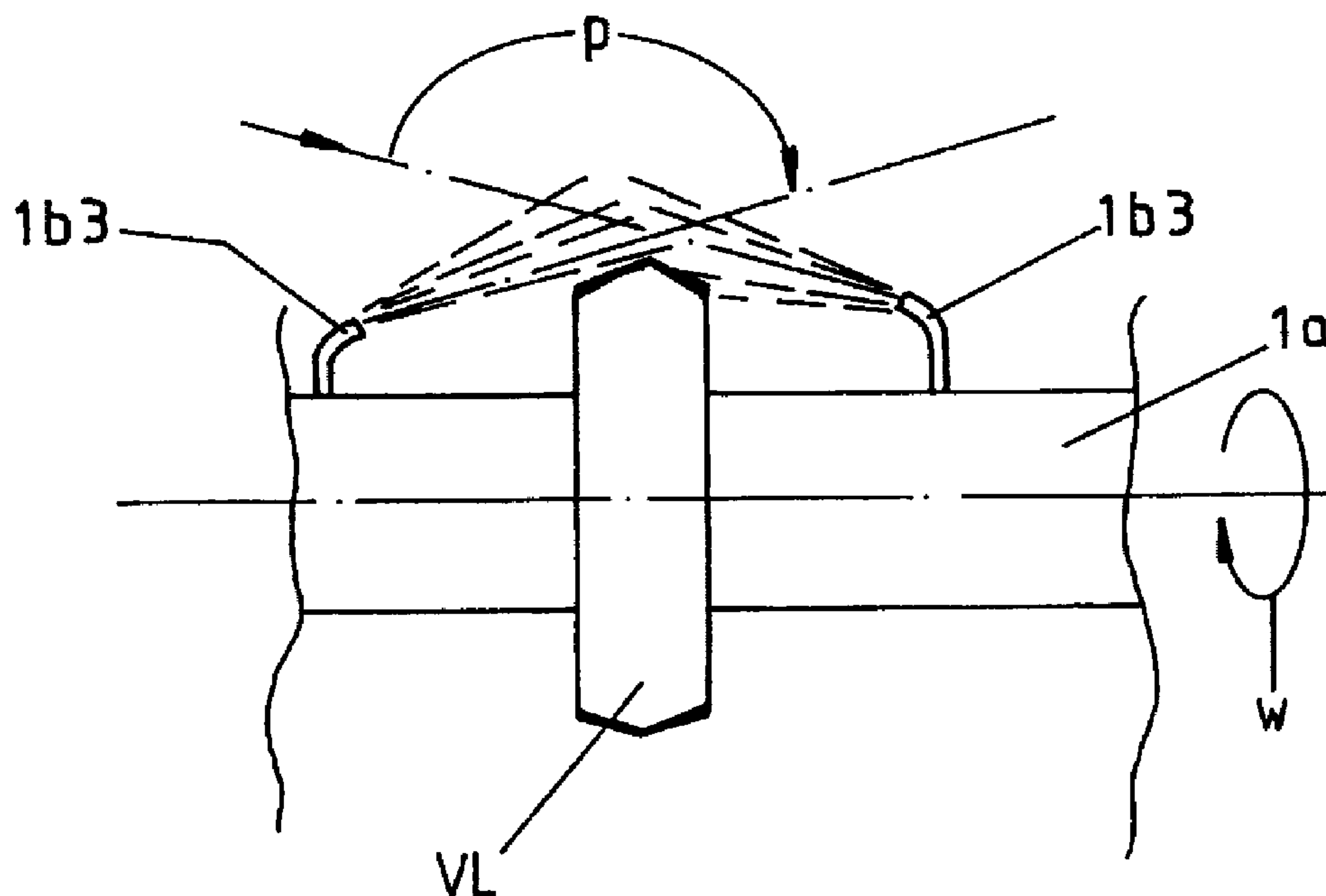

(86) Date de dépôt PCT/PCT Filing Date: 1999/09/14  
 (87) Date publication PCT/PCT Publication Date: 2000/04/13  
 (45) Date de délivrance/Issue Date: 2008/08/19  
 (85) Entrée phase nationale/National Entry: 2001/03/29  
 (86) N° demande PCT/PCT Application No.: FI 1999/000746  
 (87) N° publication PCT/PCT Publication No.: 2000/020135  
 (30) Priorité/Priority: 1998/10/05 (FI982150)

(51) Cl.Int./Int.Cl. *B08B 9/093* (2006.01),  
*B08B 3/02* (2006.01)  
 (72) Inventeur/Inventor:  
HURSKAINEN, AARNE, FI  
 (73) Propriétaire/Owner:  
HURSKAINEN, AARNE, FI  
 (74) Agent: BORDEN LADNER GERVAIS LLP

(54) Titre : AMENAGEMENT D'UN DISPOSITIF SERVANT AU LAVAGE D'UN APPAREIL DE TRAITEMENT  
 (54) Title: ARRANGEMENT OF AN APPARATUS INTENDED FOR PROCESS WASHING



(57) **Abrégé/Abstract:**

The invention relates to an arrangement of an apparatus intended for process washing, by means of which a process device is washable by means of a washing device, that moves inside the same. The washing device (1) is connected moveably in connection with the process device by means of fastening means (2), whereby the washing medium of the washing device is arranged to be led at least partly inside the body (1a) of the washing device in order to spray the washing medium to a target by means of nozzles (1b) or like existing in the body (1a) of the washing device. The apparatus comprises cleaning means in order to keep the washing device (1) itself clean essentially by influence of the washing medium to be sprayed. The cleaning means comprise one or several nozzles (1b3) placed in the body (1a) of the washing device, that is/are directed essentially to a part of the washing device and/or, that the washing device is arranged self-cleanable by arranging the appearance of one or several parts of the washing device totally visible as seen from the spraying direction (p), such as conical, inclined or in a corresponding manner.

**PCT**WORLD INTELLECTUAL PROPERTY ORGANIZATION  
International Bureau

## INTERNATIONAL APPLICATION PUBLISHED UNDER THE PATENT COOPERATION TREATY (PCT)

<p>(51) International Patent Classification <sup>7</sup> : B08B 3/02, B05B 3/00</p>	A1	<p>(11) International Publication Number: <b>WO 00/20135</b></p> <p>(43) International Publication Date: 13 April 2000 (13.04.00)</p>
<p>(21) International Application Number: PCT/FI99/00746</p> <p>(22) International Filing Date: 14 September 1999 (14.09.99)</p> <p>(30) Priority Data: 982150 5 October 1998 (05.10.98) FI</p> <p>(71)(72) Applicant and Inventor: HURSKAINEN, Aarne [FI/FI]; Peiponkuja 9, FIN-37600 Valkeakoski (FI).</p> <p>(74) Agent: KANGASMÄKI, Reijo; Finnish Patent Consulting FPC, Hermiankatu 14, FIN-33720 Tampere (FI).</p>		<p>(81) Designated States: AE, AL, AM, AT, AU, AZ, BA, BB, BG, BR, BY, CA, CH, CN, CR, CU, CZ, DE, DK, DM, EE, ES, FI, GB, GD, GE, GH, GM, HR, HU, ID, IL, IN, IS, JP, KE, KG, KP, KR, KZ, LC, LK, LR, LS, LT, LU, LV, MD, MG, MK, MN, MW, MX, NO, NZ, PL, PT, RO, RU, SD, SE, SG, SI, SK, SL, TJ, TM, TR, TT, UA, UG, US, UZ, VN, YU, ZA, ZW, ARIPO patent (GH, GM, KE, LS, MW, SD, SL, SZ, TZ, UG, ZW), Eurasian patent (AM, AZ, BY, KG, KZ, MD, RU, TJ, TM), European patent (AT, BE, CH, CY, DE, DK, ES, FI, FR, GB, GR, IE, IT, LU, MC, NL, PT, SE), OAPI patent (BF, BJ, CF, CG, CI, CM, GA, GN, GW, ML, MR, NE, SN, TD, TG).</p> <p><b>Published</b> <i>With international search report.</i> <i>In English translation (filed in Finnish).</i></p>
<p>(54) Title: ARRANGEMENT OF AN APPARATUS INTENDED FOR PROCESS WASHING</p>		
<p>(57) Abstract</p> <p>The invention relates to an arrangement of an apparatus intended for process washing, by means of which a process device is washable by means of a washing device, that moves inside the same. The washing device (1) is connected moveably in connection with the process device by means of fastening means (2), whereby the washing medium of the washing device is arranged to be led at least partly inside the body (1a) of the washing device in order to spray the washing medium to a target by means of nozzles (1b) or like existing in the body (1a) of the washing device. The apparatus comprises cleaning means in order to keep the washing device (1) itself clean essentially by influence of the washing medium to be sprayed. The cleaning means comprise one or several nozzles (1b3) placed in the body (1a) of the washing device, that is/are directed essentially to a part of the washing device and/or, that the washing device is arranged self-cleanable by arranging the appearance of one or several parts of the washing device totally visible as seen from the spraying direction (p), such as conical, inclined or in a corresponding manner.</p>		

Arrangement of an apparatus intended for process washing

5 The invention relates to an apparatus intended for process washing, by means of which a process device is washable by means of a washing device, that moves inside the same. The washing device is connected moveably in connection the process device by means of fastening means, whereby the washing medium of the washing device is arranged to be led at least partly  
10 inside the body of the washing device in order to spray the washing medium to a target by means of nozzles existing in the body of the washing device or correspondingly. The apparatus comprises cleaning means in order to keep the washing device itself clean  
15 essentially by influence of the washing medium to be sprayed.

20 It is nowadays known to use washing devices for process washing, in which the supply assembly for the washing medium is being led totally through the washing device, such as through its body and at least partly inside the fastening means connecting the same to the process device, such as e.g. an attachment  
25 frame fastened e.g. with screws, and also e.g. partly inside a running motor and gear acting as the driving device. Furthermore depending on the process device, the washing device comprises e.g. according to figures 1a and 1b a body, that rotates around an axis, that is  
30 essentially perpendicular to its longitudinal axis, or, that rotates essentially around its longitudinal axis, which body is equipped with nozzles in order to direct the washing medium being led through the same to the surfaces to be washed of the process device.  
35 For the purpose described above it is known to use most heterogeneous washers, the operating principle of which is to act by influence of the pressure or flow

of the washing liquid or, that are as described above  
moveable by external power.

5 One problem nowadays still involved with the type of  
washing devices as described above is such, that  
because the devices themselves "get dirty", which is  
naturally due to the washing process itself or in  
10 other words because of splashes and flowing down of  
the washing medium and the substances being loosened  
by the same from the walls of the process device on  
the process washing device or because of material,  
that gets collected on the process washing device  
15 during normal operation of the process device, regular  
maintenance and service measures are required, so that  
the components and fastening means belonging to the  
washing device in question would not get covered under  
a too high amount of mass, in which case the services  
20 of the said device would get more difficult and might  
even totally jeopardize operating of the device  
totally e.g. due to corrosion. In present washing  
devices it is known to use furthermore one or several  
auxiliary washers e.g. according to the one shown in  
25 Fig. 1a, which as being connected to the body of the  
process device enables spraying of the washing medium  
to the surfaces of the washing device. The solution  
above is one step in the right direction in principle,  
but an adequate result may not be obtained by the same  
in practice under all circumstances. This is due to  
30 the fact, that certain parts of the washing device  
tend to collect dirt despite an auxiliary washer  
thanks to the traditional structures of the same, that  
is why mass may get collected particularly on critical  
parts, which may cause harms, such as corrosion.

35 It is the aim of the arrangement according to this  
invention to achieve a decisive improvement in the  
problems described above and thus to raise essentially  
the level of prior art. In order to carry out this

aim, the arrangement according to the invention is primarily characterized by, that the cleaning means comprise one or several nozzles placed in the body of the washing device, that is/are directed essentially towards a part of the washing device, and/or, that the washing device is arranged self-cleanable, by arranging the appearance of one or several parts of the washing device totally visible as seen from the spraying direction, such as conical, inclined or in a corresponding manner.

As the most important advantages of the arrangement according to the invention may be mentioned simplicity and efficiency of its principle and those structures applicable for the same for most heterogeneous process purposes. Thanks to the arrangement according to the invention it is thus possible to improve significantly the operating conditions of the washing device itself. In addition to the above, the arrangement according to the invention makes the service and maintenance measures of the washing device significantly easier, because in this connection it is not any more needed to "peel" the washing device traditionally off. Thus by the arrangement according to the invention, the operating time of the washing device is essentially extended and simultaneously its service and maintenance needs are significantly decreased.

In the following description, the invention is described in detail with reference to the appended drawings, in which

Figs 1a and 1b

show some traditional washing devices being used for process washing and

Figs 2a and 2b

show details of solutions being carried out on the principle according to the invention.

5 The invention relates to an arrangement of an apparatus intended for process washing, by means of which a process device is washable by means of a washing device. The washing device 1 is connected moveably in connection with the process device by means of fastening means 2. The washing medium of the washing  
10 device is arranged to be led at least partly inside the body 1a of the washing device in order to spray the washing medium to a target by means of nozzles 1b existing in the body 1a of the washing device or correspondingly. The apparatus comprises cleaning  
15 means in order to keep the washing device 1 itself clean essentially by influence of the washing medium to be sprayed. The cleaning means comprise one or several nozzles 1b3, placed in the body 1a of the  
20 washing device, that is/are directed essentially towards a part of the washing device and/or on the other hand, the washing device is arranged self-cleanable, by arranging the appearance of one or several parts of the washing device totally visible as  
25 seen from the spraying direction p, such as conical, inclined or in a corresponding manner.

Furthermore with reference to the embodiments shown in figures 1a and 1b, the invention is being applied in  
30 connection with a washing device, that is moveable advantageously by means of a driving device K. In this case at least a part of the washing medium supply assembly 1c1 is led totally through the washing device, such as inside its body 1a and the fastening  
35 means 2, such as an attachment frame 2b fastened with screws 2a or like, connecting the same to the process device, and inside the driving device K, such as a running motor K1 and gear K2 or like. To the body 1a

of the washing device, there has been arranged furthermore at least two nozzles 1b3, that are directed e.g. according to Fig. 2a towards each other and towards a part existing in the body 1a of the washing device, such as an intermediate bearing VL or like.

Furthermore as an advantageous embodiment of the invention, the fastening means 2 of the washing device, such as the internal parts 2b' of the attachment frame 2b fastened with screws 2a, are arranged at least by the opposite outer surfaces of the same inclined towards each other on the principle shown in Fig. 2b. Furthermore with reference to the embodiment shown in Fig. 2a, the outer surfaces of the parts existing in the body 1a of the washing device, such as of the casing structure of the intermediate bearing VL, are arranged inclined in one or several parts when viewed in a cross section.

It is obvious, that the invention is not limited to the embodiments presented or described above, but it can be modified within the basic idea of the invention even to a great extent. First of all the body of the washing device may be, differing from the T-shaped shown e.g. in Fig. 1a, L-shaped or it may be formed of three or more horizontal bodies, that are attached to the center body radially. Correspondingly the body of the embodiment according to Fig. 1b, may be free by the end, that is opposite to the driving device, or it may be mounted in bearings to the washing device by both ends of the same. In addition to the above it is naturally clear, that the arrangement according to the invention may be applied in connection with a washing device, that is moveable in any possible way so, that the presented embodiments are intended only to show certain common ways based on traditional washing device structures to carry out the invention.

## CLAIMS:

1. A washing device disposed inside a process device for washing the process device, said washing device comprising:  
fastening means moveably connecting the washing device to the process device;

a body carrying a washing medium of the washing device at least partly inside the body;

nozzles disposed within the body and arranged to spray the washing medium to a target;

cleaning means for cleaning the washing device, wherein the cleaning means comprise at least one other nozzle disposed in the body and directed towards at least one part of the washing device to spray the washing medium to the at least one part of the washing device and clean the at least one part of the washing device, wherein the at least one part of the washing device has outer surfaces that are inclined such that the at least one part of the washing device is totally exposed to a spray of the washing medium from the at least one other nozzle.

2. A washing device according to claim 1, wherein the fastening means includes an attachment frame having internal parts fastened with screws, wherein the at least one other nozzle is directed towards the internal parts, and wherein the internal parts include opposite outer surfaces inclined towards each other.

3. A washing device according to claim 1, further comprising a bearing disposed in said body, wherein the at least one other nozzle is directed toward a casing structure of the bearing, and wherein the casing structure includes

outer surfaces that are inclined in one or more parts when viewed from a cross section.

4. A washing device according to claim 2, further comprising a bearing disposed in said body, wherein the at least one other nozzle is directed toward a casing structure of the bearing, and wherein the casing structure includes outer surfaces that are inclined in one or more parts when viewed from a cross section.

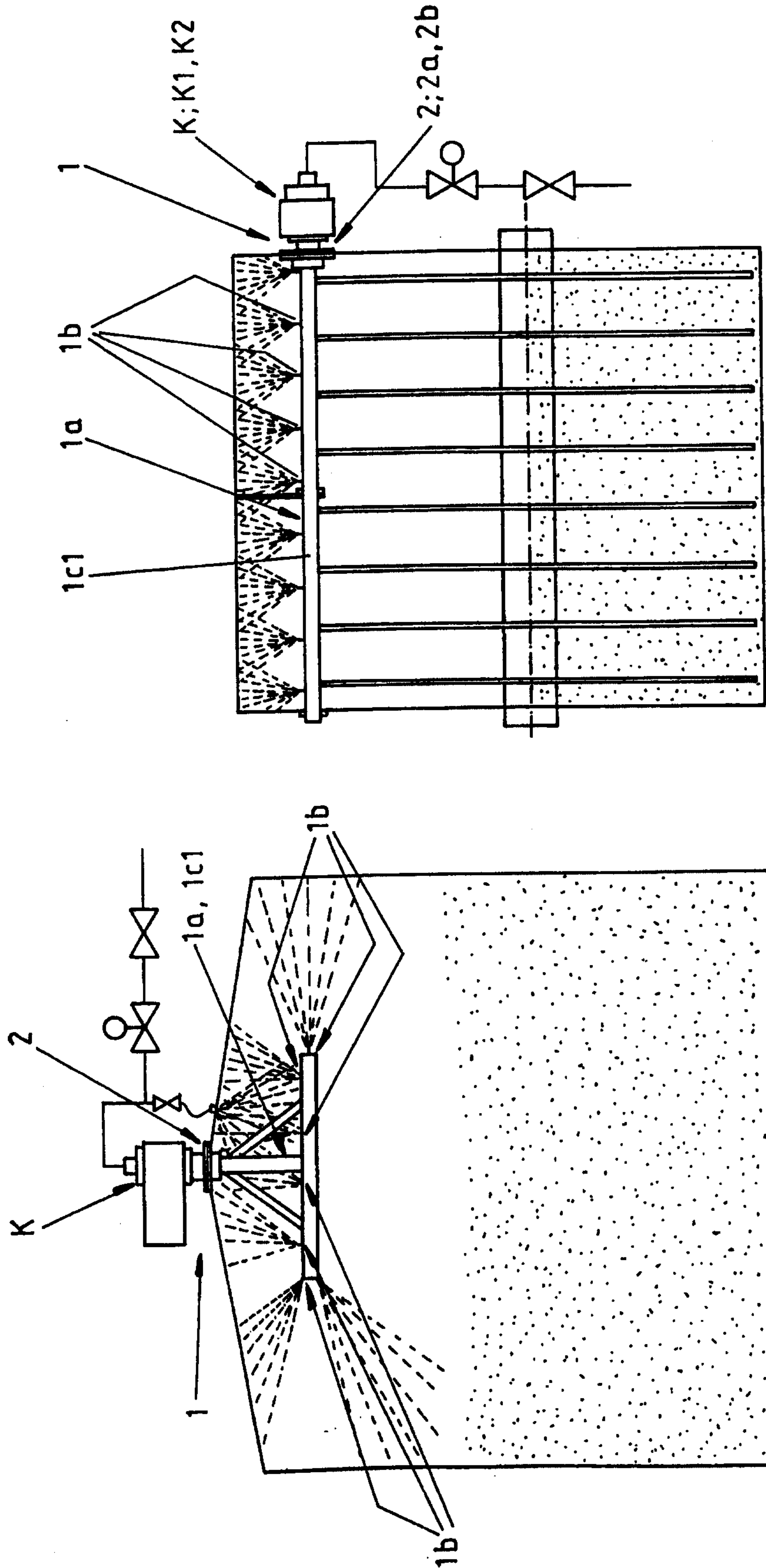

FIG.1b  
Prior art

FIG.1a  
Prior art

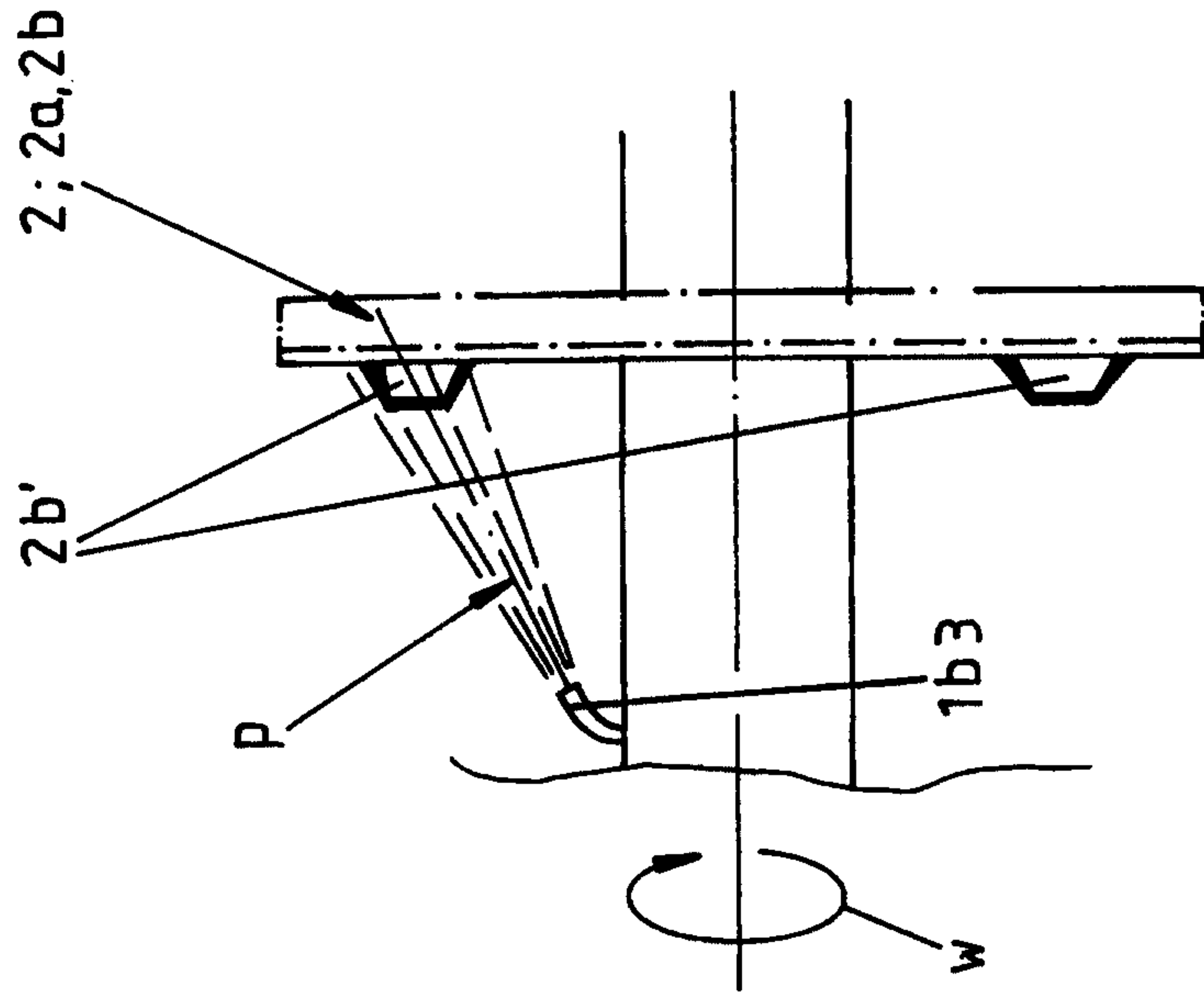

FIG. 2b

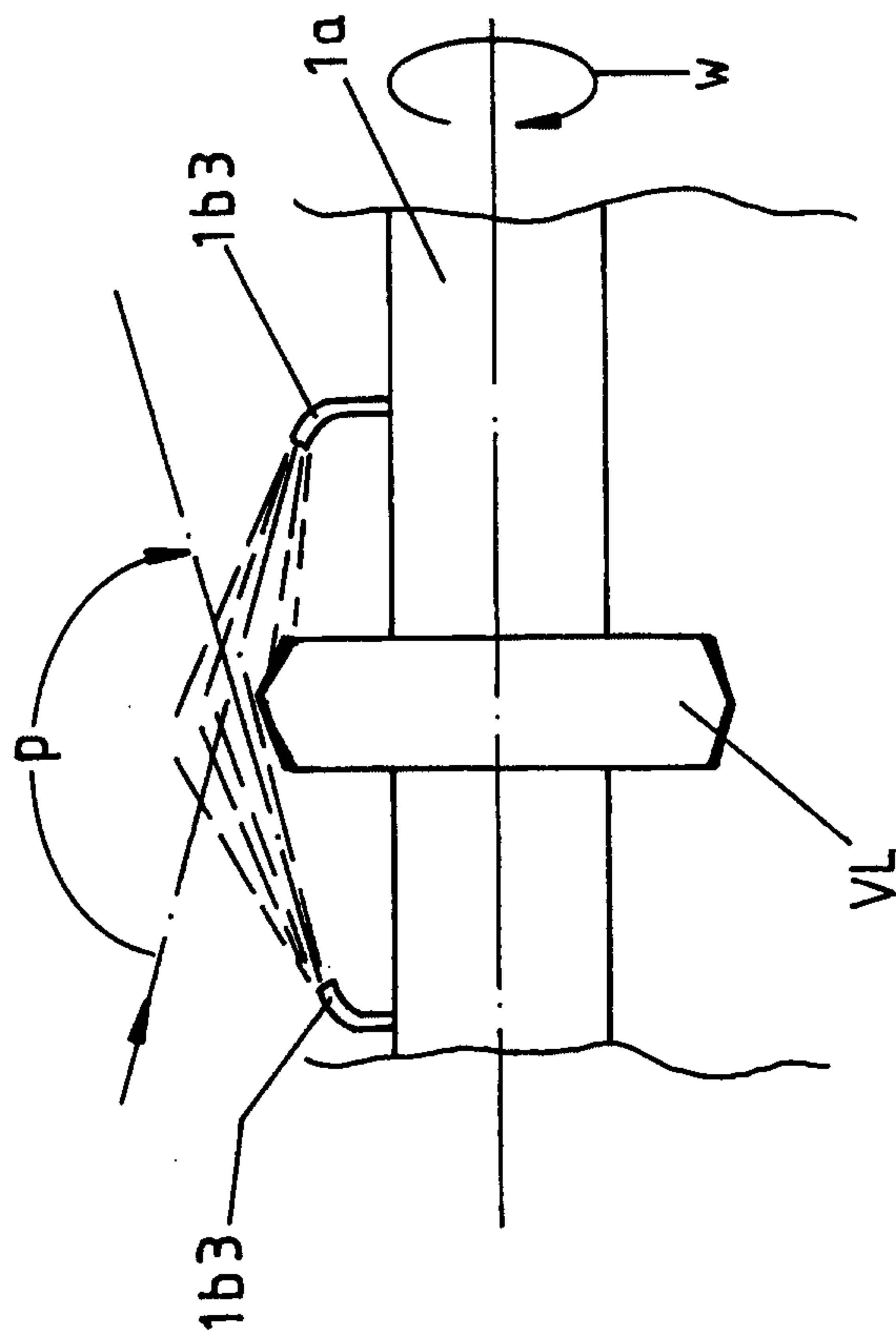

FIG. 2a

