



INTERNATIONAL APPLICATION PUBLISHED UNDER THE PATENT COOPERATION TREATY (PCT)

<p>(51) International Patent Classification ⁵ : C12N 15/27, C07K 3/00, C12P 21/02, C07K 13/00, G06F 15/60</p>	A1	<p>(11) International Publication Number: WO 94/17185</p> <p>(43) International Publication Date: 4 August 1994 (04.08.94)</p>
<p>(21) International Application Number: PCT/US94/00913</p> <p>(22) International Filing Date: 25 January 1994 (25.01.94)</p> <p>(30) Priority Data: 08/010,099 28 January 1993 (28.01.93) US</p> <p>(71) Applicant: AMGEN INC. [US/US]; Amgen Center, 1840 Dehavilland Drive, Thousand Oaks, CA 91320-1789 (US).</p> <p>(72) Inventor: OSSLUND, Timothy, D.; 475 Vista Montana, Camarillo, CA 93010 (US).</p> <p>(74) Agents: ODRE, Steven, M. et al.; Amgen Inc., Amgen Center, 1840 Dehavilland Drive, Thousand Oaks, CA 91320-1789 (US).</p>	<p>(81) Designated States: AT, AU, BB, BG, BR, BY, CA, CH, CN, CZ, DE, DK, ES, FI, GB, HU, JP, KP, KR, KZ, LK, LU, LV, MG, MN, MW, NL, NO, NZ, PL, PT, RO, RU, SD, SE, SK, UA, VN, European patent (AT, BE, CH, DE, DK, ES, FR, GB, GR, IE, IT, LU, MC, NL, PT, SE), OAPI patent (BF, BJ, CF, CG, CI, CM, GA, GN, ML, MR, NE, SN, TD, TG).</p> <p>Published <i>With international search report. Before the expiration of the time limit for amending the claims and to be republished in the event of the receipt of amendments.</i></p>	
<p>(54) Title: G-CSF ANALOG COMPOSITIONS AND METHODS</p>		
<p>(57) Abstract</p> <p>Provided herein are granulocyte colony stimulating factor ("G-CSF") analogs, compositions containing such analogs, and related compositions. In another aspect, provided herein are nucleic acids encoding the present analogs or related nucleic acids, related host cells and vectors. In yet another aspect, provided herein are computer programs and apparatuses for expressing the three dimensional structure of G-CSF and analogs thereof. In another aspect, provided herein are methods for rationally designing G-CSF analogs and related compositions. In yet another aspect, provided herein are methods for treatment using the present G-CSF analogs.</p>		

FOR THE PURPOSES OF INFORMATION ONLY

Codes used to identify States party to the PCT on the front pages of pamphlets publishing international applications under the PCT.

AT	Austria	GB	United Kingdom	MR	Mauritania
AU	Australia	GE	Georgia	MW	Malawi
BB	Barbados	GN	Guinea	NE	Niger
BE	Belgium	GR	Greece	NL	Netherlands
BF	Burkina Faso	HU	Hungary	NO	Norway
BG	Bulgaria	IE	Ireland	NZ	New Zealand
BJ	Benin	IT	Italy	PL	Poland
BR	Brazil	JP	Japan	PT	Portugal
BY	Belarus	KE	Kenya	RO	Romania
CA	Canada	KG	Kyrgyzstan	RU	Russian Federation
CF	Central African Republic	KP	Democratic People's Republic of Korea	SD	Sudan
CG	Congo	KR	Republic of Korea	SE	Sweden
CH	Switzerland	KZ	Kazakhstan	SI	Slovenia
CI	Côte d'Ivoire	LI	Liechtenstein	SK	Slovakia
CM	Cameroon	LK	Sri Lanka	SN	Senegal
CN	China	LU	Luxembourg	TD	Chad
CS	Czechoslovakia	LV	Latvia	TG	Togo
CZ	Czech Republic	MC	Monaco	TJ	Tajikistan
DE	Germany	MD	Republic of Moldova	TT	Trinidad and Tobago
DK	Denmark	MG	Madagascar	UA	Ukraine
ES	Spain	MN	Mongolia	US	United States of America
FI	Finland			UZ	Uzbekistan
FR	France			VN	Viet Nam
GA	Gabon				

G-CSF ANALOG COMPOSITIONS AND METHODS

Field of the Invention

This invention relates to granulocyte colony
5 stimulating factor ("G-CSF") analogs, compositions
containing such analogs, and related compositions. In
another aspect, the present invention relates to nucleic
acids encoding the present analogs or related nucleic
acids, related host cells and vectors. In another
10 aspect, the invention relates to computer programs and
apparatuses for expressing the three dimensional
structure of G-CSF and analogs thereof. In another
aspect, the invention relates to methods for rationally
designing G-CSF analogs and related compositions. In
15 yet another aspect, the present invention relates to
methods for treatment using the present G-CSF analogs.

Background

Hematopoiesis is controlled by two systems:
20 the cells within the bone marrow microenvironment and
growth factors. The growth factors, also called colony
stimulating factors, stimulate committed progenitor
cells to proliferate and to form colonies of
differentiating blood cells. One of these factors is
25 granulocyte colony stimulating factor, herein called
G-CSF, which preferentially stimulates the growth and
development of neutrophils, indicating a potential use
in neutropenic states. Welte et al., PNAS-USA 82: 1526-
1530 (1985); Souza et al., Science 232: 61-65 (1986) and
30 Gabilove, J. Seminars in Hematology 26: (2) 1-14
(1989).

In humans, endogenous G-CSF is detectable in
blood plasma. Jones et al., Bailliere's Clinical
Hematology 2 (1): 83-111 (1989). G-CSF is produced by
35 fibroblasts, macrophages, T cells trophoblasts,
endothelial cells and epithelial cells and is the

- 2 -

expression product of a single copy gene comprised of four exons and five introns located on chromosome seventeen. Transcription of this locus produces a mRNA species which is differentially processed, resulting in two forms of G-CSF mRNA, one version coding for a protein of 177 amino acids, the other coding for a protein of 174 amino acids, Nagata et al., EMBO J 5: 575-581 (1986), and the form comprised of 174 amino acids has been found to have the greatest specific in vivo biological activity. G-CSF is species cross-reactive, such that when human G-CSF is administered to another mammal such as a mouse, canine or monkey, sustained neutrophil leukocytosis is elicited. Moore et al., PNAS-USA 84: 7134-7138 (1987).

Human G-CSF can be obtained and purified from a number of sources. Natural human G-CSF (nhG-CSF) can be isolated from the supernatants of cultured human tumor cell lines. The development of recombinant DNA technology, see, for instance, U.S. Patent 4,810,643 (Souza) incorporated herein by reference, has enabled the production of commercial scale quantities of G-CSF in glycosylated form as a product of eukaryotic host cell expression, and of G-CSF in non-glycosylated form as a product of prokaryotic host cell expression.

G-CSF has been found to be useful in the treatment of indications where an increase in neutrophils will provide benefits. For example, for cancer patients, G-CSF is beneficial as a means of selectively stimulating neutrophil production to compensate for hematopoietic deficits resulting from chemotherapy or radiation therapy. Other indications include treatment of various infectious diseases and related conditions, such as sepsis, which is typically caused by a metabolite of bacteria. G-CSF is also useful alone, or in combination with other compounds, such as other cytokines, for growth or expansion of

- 3 -

cells in culture, for example, for bone marrow transplants.

Signal transduction, the way in which G-CSF effects cellular metabolism, is not currently thoroughly understood. G-CSF binds to a cell-surface receptor which apparently initiates the changes within particular progenitor cells, leading to cell differentiation.

Various altered G-CSF's have been reported. Generally, for design of drugs, certain changes are known to have certain structural effects. For example, deleting one cysteine could result in the unfolding of a molecule which is, in its unaltered state, is normally folded via a disulfide bridge. There are other known methods for adding, deleting or substituting amino acids in order to change the function of a protein.

Recombinant human G-CSF mutants have been prepared, but the method of preparation does not include overall structure/function relationship information. For example, the mutation and biochemical modification of Cys 18 has been reported. Kuga et al., *Biochem. Biophys. Res. Comm* 159: 103-111 (1989); Lu et al., *Arch. Biochem. Biophys.* 268: 81-92 (1989).

In U.S. Patent No. 4, 810, 643, entitled, "Production of Pluripotent Granulocyte Colony-Stimulating Factor" (as cited above), polypeptide analogs and peptide fragments of G-CSF are disclosed generally. Specific G-CSF analogs disclosed include those with the cysteins at positions 17, 36, 42, 64, and 74 (of the 174 amino acid species or of those having 175 amino acids, the additional amino acid being an N-terminal methionine) substituted with another amino acid, (such as serine), and G-CSF with an alanine in the first (N-terminal) position.

EP 0 335 423 entitled "Modified human G-CSF" reportedly discloses the modification of at least one amino group in a polypeptide having hG-CSF activity.

EP 0 272 703 entitled "Novel Polypeptide" reportedly discloses G-CSF derivatives having an amino acid substituted or deleted at or "in the neighborhood" of the N terminus.

5 EP 0 459 630, entitled "Polypeptides" reportedly discloses derivatives of naturally occurring G-CSF having at least one of the biological properties of naturally occurring G-CSF and a solution stability of at least 35% at 5 mg/ml in which the derivative has at
10 least Cys¹⁷ of the native sequence replaced by a Ser¹⁷ residue and Asp²⁷ of the native sequence replaced by a Ser²⁷ residue.

EP 0 256 843 entitled "Expression of G-CSF and Muteins Thereof and Their Uses" reportedly discloses a
15 modified DNA sequence encoding G-CSF wherein the N-terminus is modified for enhanced expression of protein in recombinant host cells, without changing the amino acid sequence of the protein.

EP 0 243 153 entitled "Human G-CSF Protein
20 Expression" reportedly discloses G-CSF to be modified by inactivating at least one yeast KEX2 protease processing site for increased yield in recombinant production using yeast.

Shaw, U.S. Patent No. 4,904,584, entitled
25 "Site-Specific Homogeneous Modification of Polypeptides," reportedly discloses lysine altered proteins.

WO/9012874 reportedly discloses cysteine altered variants of proteins.

30 Australian patent application Document No. AU-A-10948/92, entitled, "Improved Activation of Recombinant Proteins" reportedly discloses the addition of amino acids to either terminus of a G-CSF molecule for the purpose of aiding in the folding of the molecule
35 after prokaryotic expression.

- 5 -

Australian patent application Document No. AU-A-76380/91, entitled, "Muteins of the Granulocyte Colony Stimulating Factor (G-CSF)" reportedly discloses muteins of the granulocyte stimulating factor G-CSF in the
5 sequence Leu-Gly-His-Ser-Leu-Gly-Ile at position 50-56 of G-CSF with 174 amino acids, and position 53 to 59 of the G-CSF with 177 amino acids, or/and at least one of the four histadine residues at positions 43, 79, 156 and 170 of the mature G-CSF with 174 amino acids or at
10 positions 46, 82, 159, or 173 of the mature G-CSF with 177 amino acids.

GB 2 213 821, entitled "Synthetic Human Granulocyte Colony Stimulating Factor Gene" reportedly discloses a synthetic G-CSF-encoding nucleic acid
15 sequence incorporating restriction sites to facilitate the cassette mutagenesis of selected regions, and flanking restriction sites to facilitate the incorporation of the gene into a desired expression system.

20 G-CSF has reportedly been crystallized to some extent, e.g., EP 344 796, and the overall structure of G-CSF has been surmised, but only on a gross level. Bazan, Immunology Today 11: 350-354 (1990); Parry et al., J. Molecular Recognition 8: 107-110 (1988). To
25 date, there have been no reports of the overall structure of G-CSF, and no systematic studies of the relationship of the overall structure and function of the molecule, studies which are essential to the systematic design of G-CSF analogs. Accordingly, there
30 exists a need for a method of this systematic design of G-CSF analogs, and the resultant compositions.

Summary of the Invention

35 The three dimensional structure of G-CSF has now been determined to the atomic level. From this three-dimensional structure, one can now forecast with

- 6 -

substantial certainty how changes in the composition of a G-CSF molecule may result in structural changes. These structural characteristics may be correlated with biological activity to design and produce G-CSF analogs.

5 Although others had speculated regarding the three dimensional structure of G-CSF, Bazan, Immunology Today 11: 350-354 (1990); Parry et al., J. Molecular Recognition 8: 107-110 (1988), these speculations were of no help to those wishing to prepare G-CSF analogs
10 either because the surmised structure was incorrect (Parry et al., supra) and/or because the surmised structure provided no detail correlating the constituent moieties with structure. The present determination of the three-dimensional structure to the atomic level is
15 by far the most complete analysis to date, and provides important information to those wishing to design and prepare G-CSF analogs. For example, from the present three dimensional structural analysis, precise areas of hydrophobicity and hydrophilicity have been determined.

20 Relative hydrophobicity is important because it directly relates to the stability of the molecule. Generally, biological molecules, found in aqueous environments, are externally hydrophilic and internally hydrophobic; in accordance with the second law of
25 thermodynamics provides, this is the lowest energy state and provides for stability. Although one could have speculated that G-CSF's internal core would be hydrophobic, and the outer areas would be hydrophilic, one would have had no way of knowing specific
30 hydrophobic or hydrophilic areas. With the presently provided knowledge of areas of hydrophobicity/-philicity, one may forecast with substantial certainty which changes to the G-CSF molecule will affect the overall structure of the molecule.

35 As a general rule, one may use knowledge of the geography of the hydrophobic and hydrophilic regions

- 7 -

to design analogs in which the overall G-CSF structure is not changed, but change does affect biological activity ("biological activity" being used here in its broadest sense to denote function). One may correlate
5 biological activity to structure. If the structure is not changed, and the mutation has no effect on biological activity, then the mutation has no biological function. If, however, the structure is not changed and the mutation does affect biological activity, then the
10 residue (or atom) is essential to at least one biological function. Some of the present working examples were designed to provide no change in overall structure, yet have a change in biological function.

Based on the correlation of structure to
15 biological activity, one aspect of the present invention relates to G-CSF analogs. These analogs are molecules which have more, fewer, different or modified amino acid residues from the G-CSF amino acid sequence. The modifications may be by addition, substitution, or
20 deletion of one or more amino acid residues. The modification may include the addition or substitution of analogs of the amino acids themselves, such as peptidomimetics or amino acids with altered moieties such as altered side groups. The G-CSF used as a basis
25 for comparison may be of human, animal or recombinant nucleic acid-technology origin (although the working examples disclosed herein are based on the recombinant production of the 174 amino acid species of human G-CSF, having an extra N-terminus methionyl residue). The
30 analogs may possess functions different from natural human G-CSF molecule, or may exhibit the same functions, or varying degrees of the same functions. For example, the analogs may be designed to have a higher or lower biological activity, have a longer shelf-life or a
35 decrease in stability, be easier to formulate, or more difficult to combine with other ingredients. The

- 8 -

analogues may have no hematopoietic activity, and may therefore be useful as an antagonist against G-CSF effect (as, for example, in the overproduction of G-CSF). From time to time herein the present analogues
5 are referred to as proteins or peptides for convenience, but contemplated herein are other types of molecules, such as peptidomimetics or chemically modified peptides.

In another aspect, the present invention relates to related compositions containing a G-CSF
10 analog as an active ingredient. The term, "related composition," as used herein, is meant to denote a composition which may be obtained once the identity of the G-CSF analog is ascertained (such as a G-CSF analog labeled with a detectable label, related receptor or
15 pharmaceutical composition). Also considered a related composition are chemically modified versions of the G-CSF analog, such as those having attached at least one polyethylene glycol molecule.

For example, one may prepare a G-CSF analog to
20 which a detectable label is attached, such as a fluorescent, chemiluminescent or radioactive molecule.

Another example is a pharmaceutical composition which may be formulated by known techniques using known materials, see, e.g., Remington's
25 Pharmaceutical Sciences, 18th Ed. (1990, Mack Publishing Co., Easton, Pennsylvania 18042) pages 1435-1712, which are herein incorporated by reference. Generally, the formulation will depend on a variety of factors such as administration, stability, production concerns and other
30 factors. The G-CSF analog may be administered by injection or by pulmonary administration via inhalation. Enteric dosage forms may also be available for the present G-CSF analog compositions, and therefore oral administration may be effective. G-CSF analogues may be
35 inserted into liposomes or other microcarriers for delivery, and may be formulated in gels or other

compositions for sustained release. Although preferred compositions will vary depending on the use to which the composition will be put, generally, for G-CSF analogs having at least one of the biological activities of natural G-CSF, preferred pharmaceutical compositions are those prepared for subcutaneous injection or for pulmonary administration via inhalation, although the particular formulations for each type of administration will depend on the characteristics of the analog.

Another example of related composition is a receptor for the present analog. As used herein, the term "receptor" indicates a moiety which selectively binds to the present analog molecule. For example, antibodies, or fragments thereof, or "recombinant antibodies" (see Huse et al., Science 246:1275 (1989)) may be used as receptors. Selective binding does not mean only specific binding (although binding-specific receptors are encompassed herein), but rather that the binding is not a random event. Receptors may be on the cell surface or intra- or extra-cellular, and may act to effectuate, inhibit or localize the biological activity of the present analogs. Receptor binding may also be a triggering mechanism for a cascade of activity indirectly related to the analog itself. Also contemplated herein are nucleic acids, vectors containing such nucleic acids and host cells containing such nucleic acids which encode such receptors.

Another example of a related composition is a G-CSF analog with a chemical moiety attached. Generally, chemical modification may alter biological activity or antigenicity of a protein, or may alter other characteristics, and these factors will be taken into account by a skilled practitioner. As noted above, one example of such chemical moiety is polyethylene glycol. Modification may include the addition of one or more hydrophilic or hydrophobic polymer molecules, fatty

- 10 -

acid molecules, or polysaccharide molecules. Examples of chemical modifiers include polyethylene glycol, alkylpolyethylene glycols, DI-poly(amino acids), polyvinylpyrrolidone, polyvinyl alcohol, pyran
5 copolymer, acetic acid/acylation, propionic acid, palmitic acid, stearic acid, dextran, carboxymethyl cellulose, pullulan, or agarose. See, Francis, *Focus on Growth Factors* 3: 4-10 (May 1992) (published by
10 Mediscript, Mountview Court, Friern Barnet Lane, London N20 0LD, UK). Also, chemical modification may include an additional protein or portion thereof, use of a cytotoxic agent, or an antibody. The chemical modification may also include lecithin.

In another aspect, the present invention
15 relates to nucleic acids encoding such analogs. The nucleic acids may be DNAs or RNAs or derivatives thereof, and will typically be cloned and expressed on a vector, such as a phage or plasmid containing appropriate regulatory sequences. The nucleic acids
20 may be labeled (such as using a radioactive, chemiluminescent, or fluorescent label) for diagnostic or prognostic purposes, for example. The nucleic acid sequence may be optimized for expression, such as including codons preferred for bacterial expression.
25 The nucleic acid and its complementary strand, and modifications thereof which do not prevent encoding of the desired analog are here contemplated.

In another aspect, the present invention relates to host cells containing the above nucleic acids
30 encoding the present analogs. Host cells may be eukaryotic or prokaryotic, and expression systems may include extra steps relating to the attachment (or prevention) of sugar groups (glycosylation), proper folding of the molecule, the addition or deletion of
35 leader sequences or other factors incident to recombinant expression.

- 11 -

In another aspect the present invention relates to antisense nucleic acids which act to prevent or modify the type or amount of expression of such nucleic acid sequences. These may be prepared by known
5 methods.

In another aspect of the present invention, the nucleic acids encoding a present analog may be used for gene therapy purposes, for example, by placing a vector containing the analog-encoding sequence into a
10 recipient so the nucleic acid itself is expressed inside the recipient who is in need of the analog composition. The vector may first be placed in a carrier, such as a cell, and then the carrier placed into the recipient. Such expression may be localized or systemic. Other
15 carriers include non-naturally occurring carriers, such as liposomes or other microcarriers or particles, which may act to mediate gene transfer into a recipient.

The present invention also provides for computer programs for the expression (such as visual
20 display) of the G-CSF or analog three dimensional structure, and further, a computer program which expresses the identity of each constituent of a G-CSF molecule and the precise location within the overall structure of that constituent, down to the atomic level.
25 Set forth below is one example of such program. There are many currently available computer programs for the expression of the three dimensional structure of a molecule. Generally, these programs provide for inputting of the coordinates for the three dimensional
30 structure of a molecule (i.e., for example, a numerical assignment for each atom of a G-CSF molecule along an x, y, and z axis), means to express (such as visually display) such coordinates, means to alter such coordinates and means to express an image of a molecule
35 having such altered coordinates. One may program crystallographic information, i.e., the coordinates of

- 12 -

the location of the atoms of a G-CSF molecule in three dimension space, wherein such coordinates have been obtained from crystallographic analysis of said G-CSF molecule, into such programs to generate a computer program for the expression (such as visual display) of the G-CSF three dimensional structure. Also provided, therefore, is a computer program for the expression of G-CSF analog three dimensional structure. Preferred is the computer program Insight II, version 4, available from Biosym, San Diego, California, with the coordinates as set forth in FIGURE 5 input. Preferred expression means is on a Silicon Graphics 320 VGX computer, with Crystal Eyes glasses (also available from Silicon Graphics), which allows one to view the G-CSF molecule or its analog stereoscopically. Alternatively, the present G-CSF crystallographic coordinates and diffraction data are also deposited in the Protein Data Bank, Chemistry Department, Brookhaven National Laboratory, Upton, New York 119723, USA. One may use these data in preparing a different computer program for expression of the three dimensional structure of a G-CSF molecule or analog thereof. Therefore, another aspect of the present invention is a computer program for the expression of the three dimensional structure of a G-CSF molecule. Also provided is said computer program for visual display of the three dimensional structure of a G-CSF molecule; and further, said program having means for altering such visual display. Apparatus useful for expression of such computer program, particularly for the visual display of the computer image of said three dimensional structure of a G-CSF molecule or analog thereof is also therefore here provided, as well as means for preparing said computer program and apparatus.

The computer program is useful for preparation of G-CSF analogs because one may select specific sites on the G-CSF molecule for alteration and readily

- 13 -

ascertain the effect the alteration will have on the overall structure of the G-CSF molecule. Selection of said site for alteration will depend on the desired biological characteristic of the G-CSF analog. If one
5 were to randomly change said G-CSF molecule (r-met-hu-G-CSF) there would be 175^{20} possible substitutions, and even more analogs having multiple changes, additions or deletions. By viewing the three dimensional structure wherein said structure is
10 correlated with the composition of the molecule, the selection for sites of alteration is no longer a random event, but sites for alteration may be determined rationally.

As set forth above, identity of the three
15 dimensional structure of G-CSF, including the placement of each constituent down to the atomic level has now yielded information regarding which moieties are necessary to maintain the overall structure of the G-CSF molecule. One may therefore select whether to maintain
20 the overall structure of the G-CSF molecule when preparing a G-CSF analog of the present invention, or whether (and how) to change the overall structure of the G-CSF molecule when preparing a G-CSF analog of the present invention. Optionally, once one has prepared
25 such analog, one may test such analog for a desired characteristic.

One may, for example, seek to maintain the overall structure possessed by a non-altered natural or recombinant G-CSF molecule. The overall structure is
30 presented in Figures 2, 3, and 4, and is described in more detail below. Maintenance of the overall structure may ensure receptor binding, a necessary characteristic for an analog possessing the hematopoietic capabilities of natural G-CSF (if no receptor binding, signal
35 transduction does not result from the presence of the analog). It is contemplated that one class of G-CSF

- 14 -

analogs will possess the three dimensional core structure of a natural or recombinant (non-altered) G-CSF molecule, yet possess different characteristics, such as an increased ability to selectively stimulate neutrophils. Another class of G-CSF analogs are those with a different overall structure which diminishes the ability of a G-CSF analog molecule to bind to a G-CSF receptor, and possesses a diminished ability to selectively stimulate neutrophils as compared to non-altered natural or recombinant G-CSF.

For example, it is now known which moieties within the internal regions of the G-CSF molecule are hydrophobic, and, correspondingly, which moieties on the external portion of the G-CSF molecule are hydrophilic. Without knowledge of the overall three dimensional structure, preferably to the atomic level as provided herein, one could not forecast which alterations within this hydrophobic internal area would result in a change in the overall structural conformation of the molecule. An overall structural change could result in a functional change, such as lack of receptor binding, for example, and therefore, diminishment of biological activity as found in non-altered G-CSF. Another class of G-CSF analogs is therefore G-CSF analogs which possess the same hydrophobicity as (non-altered) natural or recombinant G-CSF. More particularly, another class of G-CSF analogs possesses the same hydrophobic moieties within the four helical bundle of its internal core as those hydrophobic moieties possessed by (non-altered) natural or recombinant G-CSF yet have a composition different from said non-altered natural or recombinant G-CSF.

Another example relates to external loops which are structures which connect the internal core (helices) of the G-CSF molecule. From the three dimensional structure -- including information regarding

- 15 -

the spatial location of the amino acid residues -- one may forecast that certain changes in certain loops will not result in overall conformational changes.

Therefore, another class of G-CSF analogs provided
5 herein is that having an altered external loop but possessing the same overall structure as (non-altered) natural or recombinant G-CSF. More particularly, another class of G-CSF analogs provided herein are those having an altered external loop, said loop being
10 selected from the loop present between helices A and B; between helices B and C; between helices C and D; between helices D and A, as those loops and helices are identified herein. More particularly, said loops, preferably the AB loop and/or the CD loop are altered to
15 increase the half life of the molecule by stabilizing said loops. Such stabilization may be by connecting all or a portion of said loop(s) to a portion of an alpha helical bundle found in the core of a G-CSF (or analog) molecule. Such connection may be via beta sheet, salt
20 bridge, disulfide bonds, hydrophobic interaction or other connecting means available to those skilled in the art, wherein such connecting means serves to stabilize said external loop or loops. For example, one may stabilize the AB or CD loops by connecting the AB loop
25 to one of the helices within the internal region of the molecule.

The N-terminus also may be altered without change in the overall structure of a G-CSF molecule, because the N-terminus does not effect structural
30 stability of the internal helices, and, although the external loops are preferred for modification, the same general statements apply to the N-terminus.

Additionally, such external loops may be the site(s) for chemical modification because in (non-
35 altered) natural or recombinant G-CSF such loops are relatively flexible and tend not to interfere with

- 16 -

receptor binding. Thus, there would be additional room for a chemical moiety to be directly attached (or indirectly attached via another chemical moiety which serves as a chemical connecting means). The chemical moiety may be selected from a variety of moieties available for modification of one or more function of a G-CSF molecule. For example, an external loop may provide sites for the addition of one or more polymer which serves to increase serum half-life, such as a polyethylene glycol molecule. Such polyethylene glycol molecule(s) may be added wherein said loop is altered to include additional lysines which have reactive side groups to which polyethylene glycol moieties are capable of attaching. Other classes of chemical moieties may also be attached to one or more external loops, including but not limited to other biologically active molecules, such as receptors, other therapeutic proteins (such as other hematopoietic factors which would engender a hybrid molecule), or cytotoxic agents (such as diphtheria toxin). This list is of course not complete; one skilled in the art possessed of the desired chemical moiety will have the means to effect attachment of said desired moiety to the desired external loop. Therefore, another class of the present G-CSF analogs includes those with at least one alteration in an external loop wherein said alteration provides for the addition of a chemical moiety such as at least one polyethylene glycol molecule.

Deletions, such as deletions of sites recognized by proteins for degradation of the molecule, may also be effectual in the external loops. This provides alternative means for increasing half-life of a molecule otherwise having the G-CSF receptor binding and signal transduction capabilities (i.e., the ability to selectively stimulate the maturation of neutrophils). Therefore, another class of the present G-CSF analogs

- 17 -

includes those with at least one alteration in an external loop wherein said alteration decreases the turnover of said analog by proteases. Preferred loops for such alterations are the AB loop and the CD loop.

5 One may prepare an abbreviated G-CSF molecule by deleting a portion of the amino acid residues found in the external loops (identified in more detail below), said abbreviated G-CSF molecule may have additional advantages in preparation or in biological function.

10 Another example relates to the relative charges between amino acid residues which are in proximity to each other. As noted above, the G-CSF molecule contains a relatively tightly packed four helical bundle. Some of the faces on the helices face
15 other helices. At the point (such as a residue) where a helix faces another helix, the two amino acid moieties which face each other may have the same charge, and thus tend to repel each other, which lends instability to the overall molecule. This may be eliminated by changing
20 the charge (to an opposite charge or a neutral charge) of one or both of the amino acid moieties so that there is no repelling. Therefore, another class of G-CSF analogs includes those G-CSF analogs having been altered to modify instability due to surface interactions, such
25 as electron charge location.

In another aspect, the present invention relates to methods for designing G-CSF analogs and related compositions and the products of those methods. The end products of the methods may be the G-CSF analogs
30 as defined above or related compositions. For instance, the examples disclosed herein demonstrate (a) the effects of changes in the constituents (i.e., chemical moieties) of the G-CSF molecule on the G-CSF structure and (b) the effects of changes in structure on
35 biological function. Essentially, therefore, another

- 18 -

aspect of the present invention is a method for preparing a G-CSF analog comprising the steps of:

- (a) viewing information conveying the three dimensional structure of a G-CSF molecule wherein the chemical moieties, such as each amino acid residue or each atom of each amino acid residue, of the G-CSF molecule are correlated with said structure;
- (b) selecting from said information a site on a G-CSF molecule for alteration;
- (c) preparing a G-CSF analog molecule having such alteration; and
- (d) optionally, testing such G-CSF analog molecule for a desired characteristic.

One may use the here provided computer programs for a computer-based method for preparing a G-CSF analog. Another aspect of the present invention is therefore a computer based method for preparing a G-CSF analog comprising the steps of:

- (a) providing computer expression of the three dimensional structure of a G-CSF molecule wherein the chemical moieties, such as each amino acid residue or each atom of each amino acid residue, of the G-CSF molecule are correlated with said structure;
- (b) selecting from said computer expression a site on a G-CSF molecule for alteration;
- (c) preparing a G-CSF molecule having such alteration; and
- (d) optionally, testing such G-CSF molecule for a desired characteristic.

More specifically, the present invention provides a method for preparing a G-CSF analog comprising the steps of:

- (a) viewing the three dimensional structure of a G-CSF molecule via a computer, said computer programmed (i) to express the coordinates of a G-CSF molecule in three dimensional space, and (ii) to allow

- 19 -

for entry of information for alteration of said G-CSF expression and viewing thereof;

(b) selecting a site on said visual image of said G-CSF molecule for alteration;

5 (c) entering information for said alteration on said computer;

(d) viewing a three dimensional structure of said altered G-CSF molecule via said computer;

(e) optionally repeating steps (a)-(e);

10 (f) preparing a G-CSF analog with said alteration; and

(g) optionally testing said G-CSF analog for a desired characteristic.

In another aspect, the present invention
15 relates to methods of using the present G-CSF analogs and related compositions and methods for the treatment or protection of mammals, either alone or in combination with other hematopoietic factors or drugs in the treatment of hematopoietic disorders. It is
20 contemplated that one aspect of designing G-CSF analogs will be the goal of enhancing or modifying the characteristics non-modified G-CSF is known to have.

For example, the present analogs may possess enhanced or modified activities, so, where G-CSF is
25 useful in the treatment of (for example) neutropenia, the present compositions and methods may also be of such use.

Another example is the modification of G-CSF for the purpose of interacting more effectively when
30 used in combination with other factors particularly in the treatment of hematopoietic disorders. One example of such combination use is to use an early-acting hematopoietic factor (i.e., a factor which acts earlier in the hematopoiesis cascade on relatively
35 undifferentiated cells) and either simultaneously or in seriatim use of a later-acting hematopoietic factor,

- 20 -

such as G-CSF or analog thereof (as G-CSF acts on the CFU-GM lineage in the selective stimulation of neutrophils). The present methods and compositions may be useful in therapy involving such combinations or
5 "cocktails" of hematopoietic factors.

The present compositions and methods may also be useful in the treatment of leukopenia, myelogenous leukemia, severe chronic neutropenia, aplastic anemia, glycogen storage disease, mucosistitis, and other bone
10 marrow failure states. The present compositions and methods may also be useful in the treatment of hematopoietic deficits arising from chemotherapy or from radiation therapy. The success of bone marrow transplantation, or the use of peripheral blood
15 progenitor cells for transplantation, for example, may be enhanced by application of the present compositions (proteins or nucleic acids for gene therapy) and methods. The present compositions and methods may also be useful in the treatment of infectious diseases, such
20 in the context of wound healing, burn treatment, bacteremia, septicemia, fungal infections, endocarditis, osteomyelitis, infection related to abdominal trauma, infections not responding to antibiotics, pneumonia and the treatment of bacterial inflammation may also benefit
25 from the application of the present compositions and methods. In addition, the present compositions and methods may be useful in the treatment of leukemia based upon a reported ability to differentiate leukemic cells. Welte et al., PNAS-USA 82: 1526-1530 (1985). Other
30 applications include the treatment of individuals with tumors, using the present compositions and methods, optionally in the presence of receptors (such as antibodies) which bind to the tumor cells. For review articles on therapeutic applications, see Lieshke and
35 Burgess, N.Engl.J.Med. 327: 28-34 and 99-106 (1992) both of which are herein incorporated by reference.

- 21 -

The present compositions and methods may also be useful to act as intermediaries in the production of other moieties; for example, G-CSF has been reported to influence the production of other hematopoietic factors and this function (if ascertained) may be enhanced or modified via the present compositions and/or methods.

The compositions related to the present G-CSF analogs, such as receptors, may be useful to act as an antagonist which prevents the activity of G-CSF or an analog. One may obtain a composition with some or all of the activity of non-altered G-CSF or a G-CSF analog, and add one or more chemical moieties to alter one or more properties of such G-CSF or analog. With knowledge of the three dimensional conformation, one may forecast the best geographic location for such chemical modification to achieve the desired effect.

General objectives in chemical modification may include improved half-life (such as reduced renal, immunological or cellular clearance), altered bioactivity (such as altered enzymatic properties, dissociated bioactivities or activity in organic solvents), reduced toxicity (such as concealing toxic epitopes, compartmentalization, and selective biodistribution), altered immunoreactivity (reduced immunogenicity, reduced antigenicity or adjuvant action), or altered physical properties (such as increased solubility, improved thermal stability, improved mechanical stability, or conformational stabilization). See Francis, *Focus on Growth Factors* 3: 4-10 (May 1992) (published by Mediscript, Mountview Court, Friern Barnet Lane, London N20 OLD, UK).

The examples below are illustrative of the present invention and are not intended as a limitation. It is understood that variations and modifications will occur to those skilled in the art, and it is intended that the appended claims cover all such equivalent

variations which come within the scope of the invention as claimed.

Detailed Description of the Drawings

5 FIGURE 1 is an illustration of the amino acid sequence of the 174 amino acid species of G-CSF with an additional N-terminal methionine (Seq. ID No.: 1) (Seq. ID No.: 2).

10 FIGURE 2 is an topology diagram of the crystalline structure of G-CSF, as well as hGH, pGH, GM-CSF, INF-B, IL-2, and IL-4. These illustrations are based on inspection of cited references. The length of secondary structural elements are drawn in proportion to the number of residues. A, B, C, and D helices are
15 labeled according to the scheme used herein for G-CSF. For INF- β , the original labeling of helices is indicated in parentheses.

 FIGURE 3 is an "ribbon diagram" of the three dimensional structure of G-CSF. Helix A is amino acid
20 residues 11-39 (numbered according to Figure 1, above), helix B is amino acid residues 72-91, helix C is amino acid residues 100-123, and helix D is amino acid residues 143-173. The relatively short 3^{10} helix is at amino acid residues 45-48, and the alpha helix is at
25 amino acid residues 48-53. Residues 93-95 form almost one turn of a left handed helix.

 FIGURE 4 is a "barrel diagram" of the three dimensional structure of G-CSF. Shown in various shades of gray are the overall cylinders and their orientations
30 for the three dimensional structure of G-CSF. The numbers indicate amino acid residue position according to FIGURE 1 above.

 FIGURE 5 is a list of the coordinates used to generate a computer-aided visual image of the three-
35 dimensional structure of G-CSF. The coordinates are set forth below. The columns correspond to separate field:

- 23 -

- (i) Field 1 (from the left hand side) is the atom,
- (ii) Field 2 is the assigned atom number,
- (iii) Field 3 is the atom name (according to the periodic table standard nomenclature, with CB being carbon atom Beta, CG is Carbon atom Gamma, etc.);
- (iv) Field 4 is the residue type (according to three letter nomenclature for amino acids as found in, e.g., Stryer, Biochemistry, 3d Ed., W.H. Freeman and Company, N.Y. 1988, inside back cover);
- (v) Fields 5-7 are the x-axis, y-axis and z-axis positions of the atom;
- (vi) Field 8 (often a "1.00") designates occupancy at that position;
- (vii) Field 9 designates the B-factor;
- (viii) Field 10 designates the molecule designation. Three molecules (designated a, b, and c) of G-CSF crystallized together as a unit. The designation a, b, or c indicates which coordinates are from which molecule. The number after the letter (1, 2, or 3) indicates the assigned amino acid residue position, with molecule A having assigned positions 10-175, molecule B having assigned positions 210-375, and molecule C having assigned positions 410-575. These positions were so designated so that there would be no overlap among the three molecules which crystallized together. (The "W" designation indicates water).

FIGURE 6 is a schematic representation of the strategy involved in refining the crystallization matrix for parameters involved in crystallization. The crystallization matrix corresponds to the final concentration of the components (salts, buffers and precipitants) of the crystallization solutions in the wells of a 24 well tissue culture plate. These concentrations are produced by pipetting the appropriate volume of stock solutions into the wells of the

- 24 -

microtiter plate. To design the matrix, the crystallographer decides on an upper and lower concentration of the component. These upper and lower concentrations can be pipetted along either the rows (e.g., A1-A6, B1-B6, C1-C6 or D1-D6) or along the entire tray (A1-D6). The former method is useful for checking reproducibility of crystal growth of a single component along a limited number of wells, whereas the later method is more useful in initial screening. The results of several stages of refinement of the crystallization matrix are illustrated by a representation of three plates. The increase in shading in the wells indicates a positive crystallization result which, in the final stages, would be X-ray quality crystals but in the initial stages could be oil droplets, granular precipitates or small crystals approximately less than 0.05 mm in size. Part A represents an initial screen of one parameter in which the range of concentration between the first well (A1) and last well (D6) is large and the concentration increase between wells is calculated as $((\text{concentration A1}) - (\text{concentration D6})) / 23$. Part B represents that in later stages of the crystallization matrix refinement of the concentration spread between A1 and D6 would be reduced which would result in more crystals formed per plate. Part C indicates a final stage of matrix refinement in which quality crystals are found in most wells of the plate.

Detailed Description of the Invention

The present invention grows out of the discovery of the three dimensional structure of G-CSF. This three dimensional structure has been expressed via computer program for stereoscopic viewing. By viewing this stereoscopically, structure-function relationships identified and G-CSF analogs have been designed and made.

The Overall Three Dimensional Structure of
G-CSF

The G-CSF used to ascertain the structure was a non-glycosylated 174 amino acid species having an
5 extra N-terminal methionine residue incident to bacterial expression. The DNA and amino acid sequence of this G-CSF are illustrated in FIGURE 1.

Overall, the three dimensional structure of G-CSF is predominantly helical, with 103 of the 175
10 residues forming a 4-alpha-helical bundle. The only other secondary structure is found in the loop between the first two long helices where a 4 residue 3^{10} helix is immediately followed by a 6 residue alpha helix. As shown in FIGURE 2, the overall structure has been
15 compared with the structure reported for other proteins: growth hormone (Abdel-Meguid et al., PNAS-USA 84: 6434 (1987) and Vos et al., Science 255: 305-312 (1992)), granulocyte macrophage colony stimulating factor (Diederichs et al., Science 254: 1779-1782 (1991),
20 interferon- β (Senda et al., EMBO J. 11: 3193-3201 (1992)), interleukin-2 (McKay Science 257: 1673-1677 (1992)) and interleukin-4 (Powers et al., Science 256: 1673-1677 (1992), and Smith et al., J. Mol. Biol. 224: 899-904 (1992)). Structural similarity among these
25 growth factors occurs despite the absence of similarity in their amino acid sequences.

Presently, the structural information was correlation of G-CSF biochemistry, and this can be

- 26 -

summarized as follows (with sequence position 1 being at the N-terminus):

5	<u>Sequence Position</u>	<u>Description of Structure</u>	<u>Analysis</u>
	1-10	Extended chain	Deletion causes no loss of biological activity
	Cys 18	Partially buried	Reactive with DTNB and Thimersosol but not with iodo-acetate
	34	Alternative splice site	Insertion reduces biological activity
	20-47 (inclusive)	Helix A, first disulfide and portion of AB helix	Predicted receptor binding region based on neutralizing antibody data
	20, 23, 24	Helix A	Single alanine mutation of residue(s) reduces biological activity. Predicted receptor binding (Site B).
	165-175 (inclusive)	Carboxy terminus	Deletion reduces biological activity

This biochemical information, having been gleaned from antibody binding studies, see Layton et al., Biochemistry 266: 23815-23823 (1991), was superimposed on the three-dimensional structure in order to design G-CSF analogs. The design, preparation, and testing of these G-CSF analogs is described in Example 1 below.

15

EXAMPLE 1

This Example describes the preparation of crystalline G-CSF, the visualization of the three dimensional structure of recombinant human G-CSF via

- 27 -

computer-generated image, the preparation of analogs, using site-directed mutagenesis or nucleic acid amplification methods, the biological assays and HPLC analysis used to analyze the G-CSF analogs, and the
5 resulting determination of overall structure/function relationships. All cited publications are herein incorporated by reference.

A. Use of Automated Crystallization

10 The need for a three-dimensional structure of recombinant human granulocyte colony stimulating factor (r-hu-G-CSF), and the availability of large quantities of the purified protein, led to methods of crystal growth by incomplete factorial sampling and seeding.
15 Starting with the implementation of incomplete factorial crystallization described by Jancarik and Kim, J. Appl. Crystallogr. 24: 409 (1991) solution conditions that yielded oil droplets and birefringence aggregates were ascertained. Also, software and hardware of an
20 automated pipetting system were modified to produce some 400 different crystallization conditions per day. Weber, J. Appl. Crystallogr. 20: 366-373 (1987). This procedure led to a crystallization solution which produced r-hu-G-CSF crystals.

25 The size, reproducibility and quality of the crystals was improved by a seeding method in which the number of "nucleation initiating units" was estimated by serial dilution of a seeding solution. These methods yielded reproducible growth of 2.0 mm r-hu-G-CSF
30 crystals. The space group of these crystals is $P2_12_12_1$ with cell dimensions of $a=90 \text{ \AA}$, $b=110 \text{ \AA}$ and $c=49 \text{ \AA}$, and they diffract to a resolution of 2.0 \AA .

1. Overall Methodology

35 To search for the crystallizing conditions of a new protein, Carter and Carter, J. Biol. Chem. 254:

- 28 -

122219-12223 (1979) proposed the incomplete factorial method. They suggested that a sampling of a large number of randomly selected, but generally probable, crystallizing conditions may lead to a successful
5 combination of reagents that produce protein crystallization. This idea was implemented by Jancarik and Kim, J. Appl. Crystallogr. 24: 409(1991), who described 32 solutions for the initial crystallization trials which cover a range of pH, salts and
10 precipitants. Here we describe an extension of their implementation to an expanded set of 70 solutions. To minimize the human effort and error of solution preparation, the method has been programmed for an automatic pipetting machine.

15 Following Weber's method of successive automated grid searching (SAGS), J.Cryst. Growth 90: 318-324(1988), the robotic system was used to generate a series of solutions which continually refined the crystallization conditions of temperature, pH, salts and
20 precipitant. Once a solution that could reproducibly grow crystals was determined, a seeding technique which greatly improved the quality of the crystals was developed. When these methods were combined, hundreds of diffraction quality crystals (crystals diffracting to
25 at least about 2.5 Angstroms, preferably having at least portions diffracting to below 2 Angstroms, and more preferably, approximately 1 Angstrom) were produced in a few days.

 Generally, the method for crystallization,
30 which may be used with any protein one desires to crystallize, comprises the steps of:

 (a) combining aqueous aliquots of the desired protein with either (i) aliquots of a salt solution, each aliquot having a different concentration of salt;
35 or (ii) aliquots of a precipitant solution, each aliquot having a different concentration of precipitant,

- 29 -

optionally wherein each combined aliquot is combined in the presence of a range of pH;

(b) observing said combined aliquots for precrystalline formations, and selecting said salt or precipitant combination and said pH which is efficacious in producing precrystalline forms, or, if no precrystalline forms are so produced, increasing the protein starting concentration of said aqueous aliquots of protein;

(c) after said salt or said precipitant concentration is selected, repeating step (a) with said previously unselected solution in the presence of said selected concentration; and

(d) repeating step (b) and step (a) until a crystal of desired quality is obtained.

The above method may optionally be automated, which provides vast savings in time and labor. Preferred protein starting concentrations are between 10mg/ml and 20mg/ml, however this starting concentration will vary with the protein (the G-CSF below was analyzed using 33mg/ml). A preferred range of salt solution to begin analysis with is (NaCl) of 0-2.5M. A preferred precipitant is polyethylene glycol 8000, however, other precipitants include organic solvents (such as ethanol), polyethylene glycol molecules having a molecular weight in the range of 500-20,000, and other precipitants known to those skilled in the art. The preferred pH range is pH 4.5 , 5.0, 5.5, 6.0, 6.5, 7.0, 7.5, 8.0, 8.5, and 9.0. Precrystallization forms include oils, birefringement precipitants, small crystals (< approximately 0.05 mm), medium crystals (approximately 0.5 to .5 mm) and large crystals (> approximately 0.5 mm). The preferred time for waiting to see a crystalline structure is 48 hours, although weekly observation is also preferred, and generally, after about one month, a different protein

- 30 -

concentration is utilized (generally the protein concentration is increased). Automation is preferred, using the Accuflex system as modified. The preferred automation parameters are described below.

5 Generally, protein with a concentration between 10 mg/ml and 20 mg/ml was combined with a range of NaCl solutions from 0-2.5 M, and each such combination was performed (separately) in the presence of the above range of concentrations. Once a
10 precrystallization structure is observed, that salt concentration and pH range are optimized in a separate experiment, until the desired crystal quality is achieved. Next, the precipitant concentration, in the presence of varying levels of pH is also optimized.
15 When both are optimized, the optimal conditions are performed at once to achieve the desired result (this is diagrammed in FIGURE 6).

a. Implementation of an automated pipetting system

20 Drops and reservoir solutions were prepared by an Accuflex pipetting system (ICN Pharmaceuticals, Costa Mesa, CA) which is controlled by a personal computer that sends ASCII codes through a standard serial interface. The pipetter samples six different solutions
25 by means of a rotating valve and pipettes these solutions onto a plate whose translation in a x-y coordinate system can be controlled. The vertical component of the system manipulates a syringe that is capable both of dispensing and retrieving liquid.

30 The software provided with the Accuflex was based on the SAGS method as proposed by Cox and Weber, J.Appl. Crystallogr. 20: 366-373 (1987). This method involves the systematic variation of two major crystallization parameters, pH and precipitant
35 concentration, with provision to vary two others. While

- 31 -

building on these concepts, the software used here provided greater flexibility in the design and implementation of the crystallization solutions used in the automated grid searching strategy. As a result of this flexibility the present software also created a larger number of different solutions. This is essential for the implementation of the incomplete factorial method as described in that section below.

To improve the speed and design of the automated grid searching strategy, the Accuflex pipetting system required software and hardware modifications. The hardware changes allowed the use of two different micro-titer trays, one used for handling drop and one used for sitting drop experiments, and a Plexiglas tray which held 24 additional buffer, salt and precipitant solutions. These additional solutions expanded the grid of crystallizing conditions that could be surveyed.

To utilize the hardware modifications, the pipetting software was written in two subroutines; one subroutine allows the crystallographer to design a matrix of crystallization solutions based on the concentrations of their components and the second subroutine to translate these concentrations into the computer code which pipettes the proper volumes of the solutions into the crystallization trays. The concentration matrices can be generated by either of two programs. The first program (MRF, available from Amgen, Inc., Thousand Oaks, CA) refers to a list of stock solution concentrations supplied by the crystallographer and calculates the required volume to be pipette to achieve the designated concentration. The second method, which is preferred, incorporates a spread sheet program (Lotus) which can be used to make more sophisticated gradients of precipitants or pH. The concentration matrix created by either program is

- 32 -

interpreted by the control program (SUX, a modification of the program found in the Accuflex pipetter originally and available from Amgen, Inc., Thousand Oaks, CA) and the wells are filled accordingly.

5 b. Implementation of the Incomplete Factorial Method

The convenience of the modified pipetting system for preparing diverse solutions improved the implementation of an expanded incomplete factorial
10 method. The development of a new set of crystallization solutions having "random" components was generated using the program INFAC, Carter et al., J.Cryst. Growth 90: 60-73(1988) which produced a list containing 96 random combinations of one factor from three variables.
15 Combinations of calcium and phosphate which immediately precipitated were eliminated, leaving 70 distinct combinations of precipitants, salts and buffers. These combinations were prepared using the automated pipetter and incubated for 1 week. The mixtures were inspected
20 and solutions which formed precipitants were prepared again with lower concentrations of their components. This was repeated until all wells were clear of precipitant.

 c. Crystallization of r-hu-G-CSF
25 Several different crystallization strategies were used to find a solution which produced x-ray quality crystals. These strategies included the use of the incomplete factorial method, refinement of the crystallization conditions using successive automated
30 grid searches (SAGS), implementation of a seeding technique and development of a crystal production procedure which yielded hundreds of quality crystals overnight. Unless otherwise noted the screening and production of r-hu-G-CSF crystals utilized the hanging
35 drop vapor diffusion method. Afinsen et al., Physical

- 33 -

principles of protein crystallization. In: Eisenberg (ed.), *Advances in Protein Chemistry* 41: 1-33 (1991).

The initial screening for crystallization conditions of r-hu-G-CSF used the Jancarik and Kim, J. Appl. Crystallogr. 24: 409 (1991) incomplete factorial method which resulted in several solutions that produced "precrystallization" results. These results included birefringent precipitants, oils and very small crystals (< .05 mm). These precrystallizations solutions then served as the starting points for systematic screening.

The screening process required the development of crystallization matrices. These matrices corresponded to the concentration of the components in the crystallization solutions and were created using the IBM-PC based spread sheet Lotus™ and implemented with the modified Accuflex pipetting system. The strategy in designing the matrices was to vary one crystallization condition (such as salt concentration) while holding the other conditions such as pH, and precipitant concentration constant. At the start of screening, the concentration range of the varied condition was large but the concentration was successively refined until all wells in the micro-titer tray produced the same crystallization result. These results were scored as follows: crystals, birefringement precipitate, granular precipitate, oil droplets and amorphous mass. If the concentration of a crystallization parameter did not produce at least a precipitant, the concentration of that parameter was increased until a precipitant formed. After each tray was produced, it was left undisturbed for at least two days and then inspected for crystal growth. After this initial screening, the trays were then inspected on a weekly basis.

From this screening process, two independent solutions with the same pH and precipitant but differing in salts (MgCl, LiSO₄) were identified which produced

- 34 -

small (0.1 x 0.05 x 0.05 mm) crystals. Based on these results, a new series of concentration matrices were produced which varied MgCl with respect to LiSO₄ while keeping the other crystallization parameters constant.

5 This series of experiments resulted in identification of a solution which produced diffraction quality crystals (> approximately 0.5 mm) in about three weeks. To find this crystallization growth solution (100 mM Mes pH 5.8, 380 mM MgCl₂, 220 mM LiSO₄ and 8% PEG 8k) approximately

10 8,000 conditions had been screened which consumed about 300 mg of protein.

The size of the crystals depended on the number of crystals forming per drop. Typically 3 to 5 crystals would be formed with average size of (1.0 x 0.7

15 x 0.7 mm). Two morphologies which had an identical space group (P₂₁2₁2₁) and unit cell dimensions a=90.2, b=110.2, c=49.5 were obtained depending on whether or not seeding (see below) was implemented. Without seeding, the r-hu-G-CSF crystals had one long flat

20 surface and rounded edges.

When seeding was employed, crystals with sharp faces were observed in the drop within 4 to 6 hours (0.05 by 0.05 by 0.05 mm). Within 24 hours, crystals had grown to (0.7 by 0.7 by 0.7 mm) and continued to

25 grow beyond 2 mm depending on the number of crystals forming in the drop.

d. Seeding and determination of nucleation initiation sites.

The presently provided method for seeding

30 crystals establishes the number of nucleation initiation units in each individual well used (here, after the optimum conditions for growing crystals had been determined). The method here is advantageous in that the number of "seeds" affects the quality of the

35 crystals, and this in turn affects the degree of resolution. The present seeding here also provides

- 35 -

advantages in that with seeding, G-CSF crystal grows in a period of about 3 days, whereas without seeding, the growth takes approximately three weeks.

In one series of production growth (see
5 methods), showers of small but well defined crystals were produced overnight ($<0.01 \times 0.01 \times 0.01$ mm). Crystallization conditions were followed as described above except that a pipette tip employed in previously had been reused. Presumably, the crystal showering
10 effect was caused by small nucleation units which had formed in the used tip and which provided sites of nucleation for the crystals. Addition of a small amount (0.5 ul) of the drops containing the crystal showers to a new drop under standard production growth conditions
15 resulted in a shower of crystals overnight. This method was used to produce several trays of drops containing crystal showers which we termed "seed stock".

The number of nucleation initiation units (NIU) contained within the "seed stock" drops was
20 estimated to attempt to improve the reproducibility and quality of the r-hu-G-CSF crystals. To determine the number of NIU in the "seed stock", an aliquot of the drop was serially diluted along a 96 well microtiter plate. The microtiter plate was prepared by adding 50
25 ul of a solution containing equal volumes of r-hu-G-CSF (33 mg/ml) and the crystal growth solution (described above) in each well. An aliquot (3 ul) of one of the "seed stock" drops was transferred to the first well of the microtiter plate. The solution in the well was
30 mixed and 3 ul was then transferred to the next well along the row of the microtiter plate. Each row of the microtiter plate was similarly prepared and the tray was sealed with plastic tape. Overnight, small crystals formed in the bottom of the wells of the microtiter
35 plate and the number of crystals in the wells were correlated to the dilution of the original "seed stock".

- 36 -

To produce large single crystals, the "seed stock" drop was appropriately diluted into fresh CGS and then an aliquot of this solution containing the NIU was transferred to a drop

5 Once crystallization conditions had been optimized, crystals were grown in a production method in which 3 ml each of CGS and r-hu-G-CSF (33 mg/ml) were mixed to create 5 trays (each having 24 wells). This method included the production of the refined
10 crystallization solution in liter quantities, mixing this solution with protein and placing the protein/crystallization solution in either hanging drop or sitting drop trays. This process typically yielded 100 to 300 quality crystals (>0.5 mm) in about 5 days.

15 e. Experimental Methods

Materials

Crystallographic information was obtained starting with r-hu-met-G-CSF with the amino acid sequence as provided in FIGURE 1 with a specific
20 activity of $1.0 \pm 0.6 \times 10^8 \text{U/mg}$ (as measured by cell mitogenesis assay in a 10 mM acetate buffer at pH 4.0 (in Water for Injection) at a concentration of approximately 3 mg/ml solution was concentrated with an Amicon concentrator at 75 psi using a YM10 filter. The
25 solution was typically concentrated 10 fold at 4°C and stored for several months.

Initial Screening

Crystals suitable for X-ray analysis were obtained by vapor-diffusion equilibrium using hanging
30 drops. For preliminary screening, 7 ul of the protein solution at 33 mg/ml (as prepared above) was mixed with an equal volume of the well solution, placed on siliconized glass plates and suspended over the well solution utilizing Linbro tissue culture plates (Flow
35 Laboratories, McLean, Va). All of the pipetting was performed with the Accuflex pipetter, however, trays

- 37 -

were removed from the automated pipetter after the well solutions had been created and thoroughly mixed for at least 10 minutes with a table top shaker. The Linbro trays were then returned to the pipetter which added the well and protein solutions to the siliconized cover slips. The cover slips were then inverted and sealed over 1 ml of the well solutions with silicon grease.

The components of the automated crystallization system are as follows. A PC-DOS computer system was used to design a matrix of crystallization solutions based on the concentration of their components. These matrices were produced with either MRF of the Lotus spread sheet (described above). The final product of these programs is a data file. This file contains the information required by the SUX program to pipette the appropriate volume of the stock solutions to obtain the concentrations described in the matrices. The SUX program information was passed through a serial I/O port and used to dictate to the Accuflex pipetting system the position of the valve relative to the stock solutions, the amount of solution to be retrieved, and then pipetted into the wells of the microtiter plates and the X-Y position of each well (the column/row of each well). Addition information was transmitted to the pipetter which included the Z position (height) of the syringe during filling as well as the position of a drain where the system pauses to purge the syringe between fillings of different solutions. The 24 well microtiter plate (either Linbro or Cryschem) and cover slip holder was placed on a plate which was moved in the X-Y plane. Movement of the plate allowed the pipetter to position the syringe to pipette into the wells. It also positioned the coverslips and vials and extract solutions from these sources. Prior the pipetting, the Linbro microtiter plates had a thin film of grease applied around the edges of the wells.

- 38 -

After the crystallization solutions were prepared in the wells and before they were transferred to the cover slips, the microtiter plate was removed from the pipetting system, and solutions were allowed to mix on a table top shaker for ten minutes. After mixing, the well solution was either transferred to the cover slips (in the case of the hanging drop protocol) or transferred to the middle post in the well (in the case of the sitting drop protocol). Protein was extracted from a vial and added to the coverslip drop containing the well solution (or to the post). Plastic tape was applied to the top of the Cryschem plate to seal the wells.

Production Growth

Once conditions for crystallization had been optimized, crystal growth was performed utilizing a "production" method. The crystallization solution which contained 100 mM Mes pH 5.8, 380 mM MgCl₂, 220 mM LiSO₄, and 8% PEG 8K was made in 1 liter quantities. Utilizing an Eppendorf syringe pipetter, 1 ml aliquots of this solution were pipetted into each of the wells of the Linbro plate. A solution containing 50% of this solution and 50% G-CSF (33 mg/ml) was mixed and pipetted onto the siliconized cover slips. Typical volumes of these drops were between 50 and 100 ul and because of the large size of these drops, great care was taken in flipping the coverslips and suspending the drops over the wells.

Data Collection

The structure has been refined with X-PLOR (Bruniger, X-PLOR version 3.0, A system for crystallography and NMR, Yale University, New Haven CT) against 2.2Å data collected on an R-AXIS (Molecular Structure, Corp. Houston, TX) imaging plate detector.

35

- 39 -

f. Observations

As an effective recombinant human therapeutic, r-hu-G-CSF has been produced in large quantities and gram levels have been made available for structural analysis. The crystallization methods provided herein are likely to find other applications as other proteins of interest become available. This method can be applied to any crystallographic project which has large quantities of protein (approximately >200 mg). As one skilled in the art will recognize, the present materials and methods may be modified and equivalent materials and methods may be available for crystallization of other proteins.

B. Computer Program For Visualizing The Three Dimensional Structure of G-CSF

Although diagrams, such as those in the Figures herein, are useful for visualizing the three dimensional structure of G-CSF, a computer program which allows for stereoscopic viewing of the molecule is contemplated as preferred. This stereoscopic viewing, or "virtual reality" as those in the art sometimes refer to it, allows one to visualize the structure in its three dimensional form from every angle in a wide range of resolution, from macromolecular structure down to the atomic level. The computer programs contemplated herein also allow one to change perspective of the viewing angle of the molecule, for example by rotating the molecule. The contemplated programs also respond to changes so that one may, for example, delete, add, or substitute one or more images of atoms, including entire amino acid residues, or add chemical moieties to existing or substituted groups, and visualize the change in structure.

Other computer based systems may be used; the elements being: (a) a means for entering information, such as orthogonal coordinates or other numerically

- 40 -

assigned coordinates of the three dimensional structure of G-CSF; (b) a means for expressing such coordinates, such as visual means so that one may view the three dimensional structure and correlate such three
5 dimensional structure with the composition of the G-CSF molecule, such as the amino acid composition; (c) optionally, means for entering information which alters the composition of the G-CSF molecule expressed, so that the image of such three dimensional structure displays
10 the altered composition.

The coordinates for the preferred computer program used are presented in FIGURE 5. The preferred computer program is Insight II, version 4, available from Biosym in San Diego, CA. For the raw
15 crystallographic structure, the observed intensities of the diffraction data ("F-obs") and the orthogonal coordinates are also deposited in the Protein Data Bank, Chemistry Department, Brookhaven National Laboratory, Upton, New York 119723, USA and these are herein
20 incorporated by reference.

Once the coordinates are entered into the Insight II program, one can easily display the three dimensional G-CSF molecule representation on a computer screen. The preferred computer system for display is
25 Silicon Graphics 320 VGX (San Diego, CA). For stereoscopic viewing, one may wear eyewear (Crystal Eyes, Silicon Graphics) which allows one to visualize the G-CSF molecule in three dimensions stereoscopically, so one may turn the molecule and envision molecular
30 design.

Thus, the present invention provides a method of designing or preparing a G-CSF analog with the aid of a computer comprising:

(a) providing said computer with the means for
35 displaying the three dimensional structure of a G-CSF molecule including displaying the composition of

- 41 -

moieties of said G-CSF molecule, preferably displaying the three dimensional location of each amino acid, and more preferably displaying the three dimensional location of each atom of a G-CSF molecule;

- 5 (b) viewing said display;
 (c) selecting a site on said display for alteration in the composition of said molecule or the location of a moiety; and
 (d) preparing a G-CSF analog with such alteration.

10 The alteration may be selected based on the desired structural characteristics of the end-product G-CSF analog, and considerations for such design are described in more detail below. Such considerations include the location and compositions of hydrophobic amino acid
15 residues, particularly residues internal to the helical structures of a G-CSF molecule which residues, when altered, alter the overall structure of the internal core of the molecule and may prevent receptor binding; the location and compositions of external loop
20 structures, alteration of which may not affect the overall structure of the G-CSF molecule.

FIGURES 2-4 illustrate the overall three dimensional conformation in different ways. The topological diagram, the ribbon diagram, and the barrel
25 diagram all illustrate aspects of the conformation of G-CSF.

FIGURE 2 illustrates a comparison between G-CSF and other molecules. There is a similarity of architecture, although these growth factors differ in
30 the local conformations of their loops and bundle geometrics. The up-up-down-down topology with two long crossover connections is conserved, however, among all six of these molecules, despite the dissimilarity in amino acid sequence.

35

- 42 -

FIGURE 3 illustrates in more detail the secondary structure of recombinant human G-CSF. This ribbon diagram illustrates the handedness of the helices and their positions relative to each other.

5 FIGURE 4 illustrates in a different way the conformation of recombinant human G-CSF. This "barrel" diagram illustrates the overall architecture of recombinant human G-CSF.

10 C. Preparation of Analogs Using M13
Mutagenesis

 This example relates to the preparation of G-CSF analogs using site directed mutagenesis techniques involving the single stranded bacteriophage M13, according to methods published in PCT Application No. 15 WO 85/00817 (Souza et al., published February 28, 1985, herein incorporated by reference). This method essentially involves using a single-stranded nucleic acid template of the non-mutagenized sequence, and binding to it a smaller oligonucleotide containing the 20 desired change in the sequence. Hybridization conditions allow for non-identical sequences to hybridize and the remaining sequence is filled in to be identical to the original template. What results is a double stranded molecule, with one of the two strands 25 containing the desired change. This mutagenized single strand is separated, and used itself as a template for its complementary strand. This creates a double stranded molecule with the desired change.

 The original G-CSF nucleic acid sequence used 30 is presented in FIGURE 1, and the oligonucleotides containing the mutagenized nucleic acid(s) are presented in Table 2. Abbreviations used herein for amino acid residues and nucleotides are conventional, see Stryer, Biochemistry, 3d Ed., W.H. Freeman and Company, N.Y., 35 N.Y. 1988, inside back cover.

- 43 -

The original G-CSF nucleic acid sequence was first placed into vector M13mp21. The DNA from single stranded phage M13mp21 containing the original G-CSF sequence was then isolated, and resuspended in water.

5 For each reaction, 200 ng of this DNA was mixed with a 1.5 pmole of phosphorylated oligonucleotide (Table 2) and suspended in 0.1M Tris, 0.01M MgCl₂, 0.005M DTT, 0.1mM ATP, pH 8.0. The DNAs were annealed by heating to 65°C and slowly cooling to room temperature.

10 Once cooled, 0.5mM of each ATP, dATP, dCTP, dGTP, TTP, 1 unit of T4 DNA ligase and 1 unit of Klenow fragment of E. coli polymerase 1 were added to the 1 unit of annealed DNA in 0.1M Tris, 0.025M NaCl, 0.01M MgCl₂, 0.01M DTT, pH 7.5.

15 The now double stranded, closed circular DNA was used to transfect E. coli without further purification. Plaques were screened by lifting the plaques with nitrocellulose filters, and then hybridizing the filters with single stranded DNA end-labeled with P³² for 1 hour at 55-60°C. After
20 hybridization, the filters were washed at 0-3°C below the melt temperature of the oligo (2°C for A-T, 4°C for G-C) which selectively left autoradiography signals corresponding to plaques with phage containing the
25 mutated sequence. Positive clones were confirmed by sequencing.

Set forth below are the oligonucleotides used for each G-CSF analog prepared via the M13 mutagenesis method. The nomenclature indicates the residue and the
30 position of the original amino acid (e.g., Lysine at position 17), and the residue and position of the substituted amino acid (e.g., arginine 17). A substitution involving more than one residue is indicated via superscript notation, with commas between
35 the noted positions or a semicolon indicating different residues. Deletions with no substitutions are so noted.

- 44 -

The oligonucleotide sequences used for M13-based mutagenesis are next indicated; these oligonucleotides were manufactured synthetically, although the method of preparation is not critical, any nucleic acid synthesis method and/or equipment may be used. The length of the oligo is also indicated. As indicated above, these oligos were allowed to contact the single stranded phage vector, and then single nucleotides were added to complete the G-CSF analog nucleic acid sequence.

Table 2

<u>G-CSF ANALOGS</u>	<u>SEQUENCES (5' -> 3')</u>	<u>Length (nucleotide)</u>	<u>Seq. ID</u>
Lys ¹⁷ ->Arg ¹⁷	CTT TCT GCT GCG TTG TCT GGA ACA	24	3
Lys ²⁴ ->Arg ²⁴	ACA GGT TCG TCG TAT CCA GGG TG	23	4
Lys ³⁵ ->Arg ³⁵	CAC TGC AAG AAC GTC TGT GCG CT	23	5
Lys ⁴¹ ->Arg ⁴¹	CGC TAC TTA CCG TCT GTG CCA TC	23	6
Lys ^{17, 24, 35} -> Arg ^{17, 24, 35}	CTT TCT GCT GCG TTG TCT GGA ACA ACA GGT TCG TCG TAT CCA GGG TG CAC TGC AAG AAC GTC TGT GCG CT	24 23 23	7 8 9
Lys ^{17, 24, 41} -> Arg ^{17, 24, 41}	CTT TCT GCT GCG TTG TCT GGA ACA ACA GGT TCG TCG TAT CCA GGG TG CGC TAC TTA CCG TCT GTC CCA TC	24 23 23	10 11 12
Lys ^{17, 35, 41} -> Arg ^{17, 35, 41}	CTT TCT GCT GCG TTG TCT GGA ACA CAC TGC AAG AAC GTC TGT GCG CT CGC TAC TTA CCG TCT GTG CCA TC	24 23 23	13 14 15
Lys ^{24, 35, 41} -> Arg ^{24, 35, 41}	ACA GGT TCG TCG TAT CCA GGG TG CAC TGC AAG AAC GTC TGT GCG CT CGC TAC TTA CCG TCT GTG CCA TC	23 23 23	16 17 18

Table 2 (con't)

<u>G-CSE ANALOGS</u>	<u>SEQUENCES (5' -> 3')</u>	<u>Length (nucleotide)</u>	<u>Seq. ID</u>
Lys ^{17, 24, 35, 41} ->	CTT TCT GCT GCG TTG TCT TCT GGA ACA	24	19
Arg ^{17, 24, 35, 41}	ACA GGT TCG TCG TAT CCA GGG TG	23	20
	CAC TGC AAG AAC GTC TGT GCG CT	23	21
	CGC TAC TTA CCG TCT GTG CCA TC	23	22
Cys ¹⁸ ->Ala ¹⁸	TCT GCT GAA AGC TCT GGA ACA GG	23	23
Gln ⁶⁸ ->Glu ⁶⁸	CTT GTC CAT CTG AAG CTC TTC AG	23	24
Cys ^{37, 43} ->	GAA AAA CTG TCC GCT ACT TAC AAA	37	25
Ser ^{37, 43}	CTG TCC CAT CCG G		
Gln ²⁶ ->Ala ²⁶	TTC GTA AAA TCG CGG GTG ACG G	22	26
Gln ¹⁷⁴ ->Ala ¹⁷⁴	TCA TCT GGC TGC GCC GTA ATA G	22	27
Arg ¹⁷⁰ ->Ala ¹⁷⁰	CCG TGT TCT GGC TCA TCT GGC T	22	28
Arg ¹⁶⁷ ->Ala ¹⁶⁷	GAA GTA TCT TAC GCT GTT CTG CGT	24	29
Deletion 167	GAA GTA TCT TAC TAA GTT CTG CGT C	25	30
Lys ⁴¹ ->Ala ⁴¹	CGC TAC TTA CGC ACT GTG CCA T	22	31
His ⁴⁴ ->Lys ⁴⁴	CAA ACT GTG CAA GCC GGA AGA G	22	32
Glu ⁴⁷ ->Ala ⁴⁷	CAT CCG GAA GCA CTG GTA CTG C	22	33

Table 2 (con't)

<u>G-CSF ANALOGS</u>	<u>SEQUENCES (5' -> 3')</u>	<u>Length(nucleotide)</u>	<u>Seq. ID</u>
Arg23->Ala23	GGA ACA GGT TGC TAA AAT CCA GG	23	34
Lys24->Ala24	GAA CAG GTT CGT GCG ATC CAG GGT G	25	35
Glu20->Ala20	GAA ATG TCT GGC ACA GGT TCG T	22	36
Asp28->Ala28	TCC AGG GTG CCG GTG CTG C	19	37
Met127->Glu127	AAG AGC TCG GTG AGG CAC CAG CT	23	38
Met138->Glu138	CTC AAG GTG CTG AGC CGG CAT TC	23	39
Met127->Leu127	GAG CTC GGT CTG GCA CCA GC	20	40
Met138->Leu138	TCA AGG TGC TCT GCC GGC ATT	21	41
Ser13->Ala13	TCT GCC GCA AGC CTT TCT GCT GA	23	42
Lys17->Ala17	CTT TCT GCT GGC ATG TCT GGA ACA	24	43
Gln121->Ala121	CTA TTT GGC AAG CGA TGG AAG AGC	24	44
Glu124->Ala124	CAG ATG GAA GCG CTC GGT ATG	21	45

Table 2 (con't)

<u>G-CSF ANALOGS</u>	<u>SEQUENCES (5' -> 3')</u>	<u>Length (nucleotide)</u>	<u>Seq. ID</u>
Met ^{127,138} ->	GAG CTC GGT CTG GCA CCA GC	20	46
Leu ^{127,138}	TCA AGG TGC TCT GCC GGC ATT	21	47
**Glu ²⁰ ->Ala ²⁰ ; Ser ¹³ ->Gly ¹³	GAA ATG TCT GGC ACA GGT TCG T	22	48

** This analog came about during the preparation of G-CSF analog Glu²⁰->Ala²⁰. As several clones were being sequenced to identify the Glu²⁰->Ala²⁰ analog, the Glu²⁰->Ala²⁰; Ser¹³->Gly¹³ analog was identified. This double mutant was the result of an in vitro Klenow DNA polymerase reaction mistake.

D. Preparation of G-CSF Analogs Using
DNA Amplification

This example relates to methods for producing G-CSF analogs using a DNA amplification technique.

5 Essentially, DNA encoding each analog was amplified in two separate pieces, combined, and then the total sequence itself amplified. Depending upon where the desired change in the original G-CSF DNA was to be made, internal primers were used to incorporate the change,
10 and generate the two separate amplified pieces. For example, for amplification of the 5' end of the desired analog DNA, a 5' flanking primer (complementary to a sequence of the plasmid upstream from the G-CSF original DNA) was used at one end of the region to be amplified,
15 and an internal primer, capable of hybridizing to the original DNA but incorporating the desired change, was used for priming the other end. The resulting amplified region stretched from the 5' flanking primer through the internal primer. The same was done for the 3' terminus,
20 using a 3' flanking primer (complementary to a sequence of the plasmid downstream from the G-CSF original DNA) and an internal primer complementary to the region of the intended mutation. Once the two "halves" (which may or may not be equal in size, depending on the location
25 of the internal primer) were amplified, the two "halves" were allowed to connect. Once connected, the 5' flanking primer and the 3' flanking primer were used to amplify the entire sequence containing the desired change.

30 If more than one change is desired, the above process may be modified to incorporate the change into the internal primer, or the process may be repeated using a different internal primer. Alternatively, the gene amplification process may be used with other
35 methods for creating changes in nucleic acid sequence, such as the phage based mutagenesis technique as

- 50 -

described above. Examples of process for preparing analogs with more than one change are described below.

To create the G-CSF analogs described below, the template DNA used was the sequence as in FIGURE 1
5 plus certain flanking regions (from a plasmid containing the G-CSF coding region). These flanking regions were used as the 5' and 3' flanking primers and are set forth below. The amplification reactions were performed in
10 40 ul volumes containing 10 mM Tris-HCl, 1.5 mM MgCl₂, 50 mM KCl, 0.1 mg/ml gelatin, pH 8.3 at 20°C. The 40 ul reactions also contained 0.1mM of each dNTP, 10 pmoles of each primer, and 1 ng of template DNA. Each amplification was repeated for 15 cycles. Each cycle consisted of 0.5 minutes at 94°C, 0.5 minutes at 50°C,
15 and 0.75 minutes at 72°C. Flanking primers were 20 nucleotides in length and internal primers were 20 to 25 nucleotides in length. This resulted in multiple copies of double stranded DNA encoding either the front portion or the back portion of the desired G-CSF analog.

20 For combining the two "halves," one fortieth of each of the two reactions was combined in a third DNA amplification reaction. The two portions were allowed to anneal at the internal primer location, as their ends bearing the mutation were complementary, and following a
25 cycle of polymerization, give rise to a full length DNA sequence. Once so annealed, the whole analog was amplified using the 5' and 3' flanking primers. This amplification process was repeated for 15 cycles as described above.

30 The completed, amplified analog DNA sequence was cleaved with XbaI and XhoI restriction endonuclease to produce cohesive ends for insertion into a vector. The cleaved DNA was placed into a plasmid vector, and that vector was used to transform E. coli.

35 Transformants were challenged with kanamycin at 50 ug/ml and incubated at 30°C. Production of G-CSF analog

- 51 -

protein was confirmed by polyacrylamide gel electrophoresis of a whole cell lysate. The presence of the desired mutation was confirmed by DNA sequence analysis of plasmid purified from the production isolate. Cultures were then grown, and cells were harvested, and the G-CSF analogs were purified as set forth below.

Set forth below in Table 3 are the specific primers used for each analog made using gene amplification.

Table 3

	<u>Analog</u>	<u>Internal Primer(5'->3')</u>	
	<u>Seq. ID</u>		
15	His ⁴⁴ ->Ala ⁴⁴	5'primer-TTCCGGAGCGCACAGTTTG	49
		3'primer-CAAAGTGTGGGCTCCGGAAGAGC	50
	Thr ¹¹⁷ ->Ala ¹¹⁷	5'primer-ATGCCAAATTGCAGTAGCAAAG	51
		3'primer-CTTTGCTACTGCAATTTGGCAACA	52
20	Asp ¹¹⁰ ->Ala ¹¹⁰	5'primer-ATCAGCTACTGCTAGCTGCAGA	53
		3'primer-TCTGCAGCTAGCAGTAGCTGACT	54
	Gln ²¹ ->Ala ²¹	5'primer-TTACGAACCGCTTCCAGACATT	55
25		3'primer-AATGTCTGGAAGCGGTTCGTAAAAT	56
	Asp ¹¹³ ->Ala ¹¹³	5'primer-GTAGCAAATGCAGCTACATCTA	57
		3'primer-TAGATGTAGCTGCATTTGCTACTAC	58
30	His ⁵³ ->Ala ⁵³	5'primer-CCAAGAGAAGCACCCAGCAG	59
		3'primer-CTGCTGGGTGCTTCTCTTGGGA	60

For each analog, the following 5' flanking primer was used:

5'-CACTGGCGGTGATAATGAGC 61

- 53 -

DNA fragment was cut and isolated that contained the DNA mutation Gln²¹->Glu²¹.

The "A" and "B" fragments were ligated together with a 4.8 kilo-base pair XbaI to BsmI DNA plasmid vector fragment. The ligation mix consisted of
5 equal molar DNA restriction fragments, ligation buffer (25 mM Tris-HCl pH 7.8, 10 mM MgCl₂, 2 mM DTT, 0.5 mM rATP, and 100 ug/ml BSA) and T4 DNA ligase and was incubated overnight at 14°C. The ligated DNA was then
10 transformed into E. coli FM5 cells by electroporation using a Bio Rad Gene Pulsar apparatus (BioRad, Richmond, CA). A clone was isolated and the plasmid construct verified to contain the two mutations by DNA sequencing. This 'intermediate' vector also contained a deletion of
15 a 193 base pair BsmI to BsmI DNA fragment. The final plasmid vector was constructed by ligation and transformation (as described above) of DNA fragments obtained by cutting and isolating a 2 kilo-base pair SstI to BamHI DNA fragment from the intermediate vector,
20 a 2.8 kbp SstI to EcoRI DNA fragment from the plasmid vector, and a 360 bp BamHI to EcoRI DNA fragment from the plasmid vector. The final construct was verified by DNA sequencing the G-CSF gene. Cultures were grown, and the cells were harvested, and the G-CSF analogs were
25 purified as set forth below.

As indicated above, any combination of mutagenesis techniques may be used to generate a G-CSF analog nucleic acid (and expression product) having one or more than one alteration. The two examples above,
30 using M13-based mutagenesis and gene amplification-based mutagenesis, are illustrative.

E. Expression of G-CSF Analog DNA

The G-CSF analog DNAs were then placed into a plasmid vector and used to transform E. coli strain FM5
35 (ATCC#53911). The present G-CSF analog DNAs contained on plasmids and in bacterial host cells are available

- 54 -

from the American Type Culture Collection, Rockville, MD, and the accession designations are indicated below.

One liter cultures were grown in broth containing 10g tryptone, 5g yeast extract and 5g NaCl) at 30°C until reaching a density at A^{600} of 0.5, at which point they were rapidly heated to 42°C. The flasks were allowed to continue shaking at for three hours.

Other prokaryotic or eukaryotic host cells may also be used, such as other bacterial cells, strains or species, mammalian cells in culture (COS, CHO or other types) insect cells or multicellular organs or organisms, or plant cells or multicellular organs or organisms, and a skilled practitioner will recognize the appropriate host. The present G-CSF analogs and related compositions may also be prepared synthetically, as, for example, by solid phase peptide synthesis methods, or other chemical manufacturing techniques. Other cloning and expression systems will be apparent to those skilled in the art.

20 F. Purification of G-CSF Analog Protein

Cells were harvested by centrifugation (10,000 x G, 20 minutes, 4°C). The pellet (usually 5 grams) was resuspended in 30 ml of 1mM DTT and passed three times through a French press cell at 10,000 psi. The broken cell suspension was centrifuged at 10,000g for 30 minutes, the supernatant removed, and the pellet resuspended in 30-40 ml water. This was recentrifuged at 10,000 x G for 30 minutes, and this pellet was dissolved in 25 ml of 2% Sarkosyl and 50mM Tris at pH 8. Copper sulfate was added to a concentration of 40uM, and the mixture was allowed to stir for at least 15 hours at 15-25°C. The mixture was then centrifuged at 20,000 x G for 30 minutes. The resultant solubilized protein mixture was diluted four-fold with 13.3 mM Tris, pH 7.7, the Sarkosyl was removed, and the supernatant was then applied to a DEAE-cellulose (Whatman DE-52) column

- 55 -

equilibrated in 20mM Tris, pH 7.7. After loading and washing the column with the same buffer, the analogs were eluted with 20mM Tris /NaCl (between 35mM to 100mM depending on the analog, as indicated below), pH 7.7.

5 For most of the analogs, the eluent from the DEAE column was adjusted to a pH of 5.4, with 50% acetic acid and diluted as necessary (to obtain the proper conductivity) with 5mM sodium acetate pH 5.4. The solution was then loaded onto a CM-sepharose column equilibrated in 20 mM

10 sodium acetate, pH 5.4. The column was then washed with 20mM NaAc, pH 5.4 until the absorbance at 280 nm was approximately zero. The G-CSF analog was then eluted with sodium acetate/NaCl in concentrations as described below in Table 4. The DEAE column eluents for those

15 analogs not applied to the CM-sepharose column were dialyzed directly into 10mM NaAc, ph 4.0 buffer. The purified G-CSF analogs were then suitably isolated for in vitro analysis. The salt concentrations used for eluting the analogs varied, as noted above. Below, the

20 salt concentrations for the DEAE cellulose column and for the CM-sepharose column are listed:

Table 4
Salt Concentrations

25

<u>Analog</u>	<u>DEAE Cellulose</u>	<u>CM-Sepharose</u>
Lys17->Arg17	35mM	37.5mM
Lys24->Arg24	35mM	37.5mM
Lys35->Arg35	35mM	37.5mM
Lys41->Arg41	35mM	37.5mM
Lys17,24,35->Arg17,24,35	35mM	37.5mM
Lys17,35,41->Arg17,35,41	35mM	37.5mM

Table 4 Con't

<u>Analog</u>	<u>DEAE Cellulose</u>	<u>CM-Sepharose</u>
Lys ^{24,35,41} -	35mM	37.5mM
>Arg ^{24,35,41}		
Lys ^{17,24,35,41}	35mM	37.5mM
->Arg ^{17,24,35,41}		
Lys ^{17,24,41} -	35mM	37.5mM
>Arg ^{17,24,41}		
Gln ⁶⁸ ->Glu ⁶⁸	60mM	37,5mM
Cys ^{37,43} ->Ser ^{37,43}	40mM	37.5mM
Gln ²⁶ ->Ala ²⁶	40mM	40mM
Gln ¹⁷⁴ ->Ala ¹⁷⁴	40mM	40mM
Arg ¹⁷⁰ ->Ala ¹⁷⁰	40mM	40mM
Arg ¹⁶⁷ ->Ala ¹⁶⁷	40mM	40mM
Deletion 167*	N/A	N/A
Lys ⁴¹ ->Ala ⁴¹	160mM	40mM
His ⁴⁴ ->Lys ⁴⁴	40mM	60mM
Glu ⁴⁷ ->Ala ⁴⁷	40mM	40mM
Arg ²³ ->Ala ²³	40mM	40mM
Lys ²⁴ ->Ala ²⁴	120mM	40mM
Glu ²⁰ ->Ala ²⁰	40mM	60mM
Asp ²⁸ ->Ala ²⁸	40mM	80mM
Met ¹²⁷ ->Glu ¹²⁷	80mM	40mM
Met ¹³⁸ ->Glu ¹³⁸	80mM	40mM
Met ¹²⁷ ->Leu ¹²⁷	40mM	40mM
Met ¹³⁸ ->Leu ¹³⁸	40mM	40mM
Cys ¹⁸ ->Ala ¹⁸	40mM	37.5mM
Gln ^{12,21} ->Glu ^{12,21}	60mM	37.5mM
Gln ^{12,21,68} -	60mM	37.5mM
>Glu ^{12,21,68}		
Glu ²⁰ ->Ala ²⁰ ;		
Ser ¹³		
->Gly ¹³	40mM	80mM

Table 4 Con't

<u>Analog</u>	<u>DEAE Cellulose</u>	<u>CM-Sepharose</u>
Met ^{127,138} -	40mM	40mM
>Leu ^{127,138}		
Ser ¹³ ->Ala ¹³	40mM	40mM
Lys ¹⁷ ->Ala ¹⁷	80mM	40mM
Gln ¹²¹ ->Ala ¹²¹	40mM	60mM
Gln ²¹ ->Ala ²¹	50mM	Gradient 0 -150mM
His ⁴⁴ ->Ala ⁴⁴ **	40mM	N/A
His ⁵³ ->Ala ⁵³ **	50mM	N/A
Asp ¹¹⁰ ->Ala ¹¹⁰ **	40mM	N/A
Asp ¹¹³ ->Ala ¹¹³ **	40mM	N/A
Thr ¹¹⁷ ->Ala ¹¹⁷ **	50mM	N/A
Asp ²⁸ ->Ala ²⁸ ;	50mM	N/A
Asp ¹¹⁰		
Ala ¹¹⁰ **		
Glu ¹²⁴ ->Ala ¹²⁴ **	40mM	40mM

* For Deletion 167, the data are unavailable.

** For these analogs, the DEAE cellulose column alone was use for purification.

5 The above purification methods are illustrative, and a skilled practitioner will recognize that other means are available for obtaining the present G-CSF analogs.

G. Biological Assays

10 Regardless of which methods were used to create the present G-CSF analogs, the analogs were subject to assays for biological activity. Tritiated thymidine assays were conducted to ascertain the degree of cell division. Other biological assays, however, may
15 be used to ascertain the desired activity. Biological assays such as assaying for the ability to induce terminal differentiation in mouse WEHI-3B (D+) leukemic cell line, also provides indication of G-CSF activity.

- 58 -

See Nicola, et al., Blood 54: 614-27 (1979). Other in vitro assays may be used to ascertain biological activity. See Nicola, Annu. Rev. Biochem. 58: 45-77 (1989). In general, the test for biological activity
5 should provide analysis for the desired result, such as increase or decrease in biological activity (as compared to non-altered G-CSF), different biological activity (as compared to non-altered G-CSF), receptor affinity analysis, or serum half-life analysis. The list is
10 incomplete, and those skilled in the art will recognize other assays useful for testing for the desired end result.

The ³H-thymidine assay was performed using standard methods. Bone marrow was obtained from
15 sacrificed female Balb C mice. Bone marrow cells were briefly suspended, centrifuged, and resuspended in a growth medium. A 160 ul aliquot containing approximately 10,000 cells was placed into each well of a 96 well micro-titer plate. Samples of the purified
20 G-CSF analog (as prepared above) were added to each well, and incubated for 68 hours. Tritiated thymidine was added to the wells and allowed to incubate for 5 additional hours. After the 5 hour incubation time, the cells were harvested, filtered, and thoroughly rinsed.
25 The filters were added to a vial containing scintillation fluid. The beta emissions were counted (LKB Betaplate scintillation counter). Standards and analogs were analyzed in triplicate, and samples which fell substantially above or below the standard curve
30 were re-assayed with the proper dilution. The results reported here are the average of the triplicate analog data relative to the unaltered recombinant human G-CSF standard results.

H. HPLC Analysis

35 High pressure liquid chromatography was performed on purified samples of analog. Although peak

- 59 -

position on a reverse phase HPLC column is not a definitive indication of structural similarity between two proteins, analogs which have similar retention times may have the same type of hydrophobic interactions with the HPLC column as the non-altered molecule. This is one indication of an overall similar structure.

Samples of the analog and the non-altered recombinant human G-CSF were analyzed on a reverse phase (0.46 x 25 cm) Vydac 214TP54 column (Separations Group, Inc. Hesperia, CA). The purified analog G-CSF samples were prepared in 20 mM acetate and 40 mM NaCl solution buffered at pH 5.2 to a final concentration of 0.1 mg/ml to 5 mg/ml, depending on how the analog performed in the column. Varying amounts (depending on the concentration) were loaded onto the HPLC column, which had been equilibrated with an aqueous solution containing 1% isopropanol, 52.8% acetonitrile, and .38% trifluoro acetate (TFA). The samples were subjected to a gradient of 0.86%/minute acetonitrile, and .002% TFA.

I. Results

Presented below are the results of the above biological assays and HPLC analysis. Biological activity is the average of triplicate data and reported as a percentage of the control standard (non-altered G-CSF). Relative HPLC peak position is the position of the analog G-CSF relative to the control standard (non-altered G-CSF) peak. The "+" or "-" symbols indicate whether the analog HPLC peak was in advance of or followed the control standard peak (in minutes). Not all of the variants had been analyzed for relative HPLC peak, and only those so analyzed are included below. Also presented are the American Type Culture Collection designations for E. coli host cells containing the nucleic acids coding for the present analogs, as prepared above.

Table 5

Seq. ID	Variant	Analog	Relative HPLC Peak	ATCC No.	% Normal G-CSF Activity
67	1	Lys17->Arg17	N/A	69184	N/A
68	2	Lys24->Arg24	N/A	69185	N/A
69	3	Lys35->Arg35	N/A	69186	N/A
70	4	Lys41->Arg41	N/A	69187	N/A
71	5	Lys17,24,35->Arg17,24,35	N/A	69189	N/A
72	6	Lys17,35,41->Arg17,35,41	N/A	69192	N/A
73	7	Lys24,35,41->Arg24,35,41	N/A	69191	N/A
74	8	Lys17,24,35,41 ->Arg17,24,35,41	N/A	69193	N/A
75	9	Lys17,24,41->Arg17,24,41	N/A	69190	N/A
76	10	Gln68->Glu68	N/A	69196	N/A
77	11	Cys37,43->Ser37,43	N/A	69197	N/A
78	12	Gln26->Ala26	+ .96	69201	51%
79	13	Gln174->Ala174	+ .14	69202	100%
80	14	Arg170->Ala170	+ .78	69203	100%

Table 5 Con't

Seq. ID	Variant	Analog	Relative HPLC Peak	ATCC No.	% Normal G-CSF Activity
81	15	Arg167->Ala167	+ .54	69204	110%
82	16	Deletion 167	- .99	69207	N/A
83	17	Lys41->Ala41	+ .25	69208	81%
84	18	His44->Lys44	-1.53	69212	70%
85	19	Glu47->Ala47	+ .14	69205	0%
86	20	Arg23->Ala23	- .03	69206	31%
87	21	Lys24->Ala24	+1.95	69213	0%
88	22	Glu20->Ala20	-0.07	69211	0%
89	23	Asp28->Ala28	- .30	69210	147%
90	24	Met127->Glu127	N/A	69223	N/A
91	25	Met138->Glu138	N/A	69222	N/A
92	26	Met127->Leu127	N/A	69198	N/A
93	27	Met138->Leu138	N/A	69199	N/A
94	28	Cys18->Ala18	N/A	69188	N/A
95	29	Gln12,21->Glu12,21	N/A	69194	N/A
96	30	Gln12,21,68->Glu12,21,68	N/A	69195	N/A
97	31	Glu20->Ala20; Ser13	+1.74	69209	0%

Table 5 Con't

Seq. ID	Variant	Analog	Relative HPLC Peak	ATCC No.	% Normal G-CSF Activity
		->Gly13			
98	32	Met127,138->Leu127,138	+1.43	69200	98%
99	33	Ser13->Ala13	0	69221	110%
100	34	Lys17->Ala17	+0.50	69226	70%
101	35	Gln121->Ala121	+2.7	69225	100%
102	36	Gln21->Ala21	+0.63	69217	9.6%
103	37	His44->Ala44	+1.52	69215	10.8%
104	38	His53->Ala53	+0.99	69219	8.3%
105	39	Asp110->Ala110	+1.97	69216	29%
106	40	Asp113->Ala113	-0.34	69218	0%
107	41	Thr117->Ala117	+0.4	69214	9.7%
108	42	Asp28->Ala28; Asp110 Ala110	+3.2	69220	20.6%

Table 5 Con't

Seq. ID	Variant	Analog	Relative		ATCC No.	% Normal G-CSF Activity
			HPLC Peak	ATCC No.		
109	43	Glu ¹²⁴ ->Ala ¹²⁴	+0.16	69224	75%	
110	44	Phe ¹¹⁴ ->Val ¹¹⁴ , T ¹¹⁷ ->A ¹¹⁷ **	+0.53		0%	

**This analog was apparently a result of an inadvertent error in the oligo which was used to prepare number 41, above (Thr¹¹⁷->Ala¹¹⁷), and thus was prepared identically to the process used for that analog.

"N/A" indicates data which are not available.

1. Identification of Structure-Function Relationships

The first step used to design the present analogs was to determine what moieties are necessary for structural integrity of the G-CSF molecule. This was done at the amino acid residue level, although the atomic level is also available for analysis. Modification of the residues necessary for structural integrity results in change in the overall structure of the G-CSF molecule. This may or may not be desirable, depending on the analog one wishes to produce. The working examples here were designed to maintain the overall structural integrity of the G-CSF molecule, for the purpose of maintain G-CSF receptor binding of the analog to the G-CSF receptor (as used in this section below, the "G-CSF receptor" refers to the natural G-CSF receptor, found on hematopoietic cells). It was assumed, and confirmed by the studies presented here, that G-CSF receptor binding is a necessary step for at least one biological activity, as determined by the above biological assays.

As can be seen from the figures, G-CSF (here, recombinant human met-G-CSF) is an antiparallel 4-alpha helical bundle with a left-handed twist, and with overall dimensions of 45 Å x 30Å x 24Å. The four helices within the bundle are referred to as helices A, B, C and D, and their connecting loops are known as the AB, BC and CD loops. The helix crossing angles range from -167.5° to -159.4°. Helices A, B, and C are straight, whereas helix D contains two kinds of structural characteristics, at Gly 150 and Ser 160 (of the recombinant human met-G-CSF). Overall, the G-CSF molecules is a bundle of four helices, connected in series by external loops. This structural information was then correlated with known functional information. It was known that residues (including methionine at

- 65 -

position 1) 47, 23, 24, 20, 21, 44, 53, 113, 110, 28 and 114 may be modified, and the effect on biological activity would be substantial.

The majority of single mutations which lowered biological activity were centered around two regions of G-CSF that are separated by 30Å, and are located on different faces of the four helix bundle. One region involves interactions between the A helix and the D helix. This is further confirmed by the presence of salt bridges in the non-altered molecule as follows:

Atom	Helix	Atom	Helix	Distance
Arg 170 N1	D	Tyr 166 OH	A	3.3
Tyr 166 OH	D	Arg 23 N2	A	3.3
Glu 163 OE1	D	Arg 23 N1	A	2.8
Arg 23 N1	A	Gln 26 OE1	A	3.1
Gln 159 NE2	D	Gln 26 O	A	3.3

Distances reported here were for molecule A, as indicated in FIGURE 5 (wherein three G-CSF molecules crystallized together and were designated as A, B, and C). As can be seen, there is a web of salt bridges between helix A and helix D, which act to stabilize the helix A structure, and therefore affect the overall structure of the G-CSF molecule.

The area centering around residues Glu 20, Arg 23 and Lys 24 are found on the hydrophilic face of the A helix (residues 20-37). Substitution of the residues with the non-charged alanine residue at positions 20 and 23 resulted in similar HPLC retention times, indicating similarity in structure. Alteration of these sites altered the biological activity (as indicated by the present assays). Substitution at Lys 24 altered biological activity, but did not result in a similar HPLC retention time as the other two alterations.

- 66 -

The second site at which alteration lowered biological activity involves the AB helix. Changing glutamine at position 47 to alanine (analog no. 19, above) reduced biological activity (in the thymidine uptake assay) to zero. The AB helix is predominantly hydrophobic, except at the amino and carboxy termini; it contains one turn of a 3^{10} helix. There are two histadines at each termini (His 44 and His 56) and an additional glutamate at residue 46 which has the potential to form a salt bridge to His 44. The fourier transformed infra red spectrographic analysis (FTIR) of the analog suggests this analog is structurally similar to the non-altered recombinant G-CSF molecule. Further testing showed that this analog would not crystallize under the same conditions as the non-altered recombinant molecule.

Alterations at the carboxy terminus (Gln 174, Arg 167 and Arg 170) had little effect on biological activity. In contrast, deletion of the last eight residues (167-175) lowered biological activity. These results may indicate that the deletion destabilizes the overall structure which prevents the mutant from proper binding to the G-CSF receptor (and thus initiating signal transduction).

Generally, for the G-CSF internal core -- the internal four helix bundle lacking the external loops -- the hydrophobic internal residues are essential for structural integrity. For example, in helix A, the internal hydrophobic residues are (with methionine being position 1) Phe 14, Cys 18, Val 22, Ile 25, Ile 32 and Leu 36. Generally, for the G-CSF internal core -- the internal four helix bundle lacking the external loops -- the hydrophobic internal residues are essential for structural integrity. For example, in helix A, the internal hydrophobic residues are (with methionine being position 1 as in FIGURE 1) Phe 14, Cys 18, Val 22, Ile

- 67 -

25, Ile 32 and Leu 36. The other hydrophobic residues (again with the met at position 1) are: helix B, Ala 72, Leu 76, Leu 79, Leu 83, Tyr 86, Leu 90 Leu 93; helix C, Leu 104, Leu 107, Val 111, Ala 114, Ile 118, Met 122; 5 and helix D, Val 154, Val 158, Phe 161, Val 164, Val 168, Leu 172.

The above biological activity data, from the presently prepared G-CSF analogs, demonstrate that modification of the external loops interfere least with 10 G-CSF overall structure. Preferred loops for analog preparation are the AB loop and the CD loop. The loops are relatively flexible structures as compared to the helices. The loops may contribute to the proteolysis of the molecule. G-CSF is relatively fast acting in vivo 15 as the purpose the molecule serves is to generate a response to a biological challenge, i.e., selectively stimulate neutrophils. The G-CSF turnover rate is also relatively fast. The flexibility of the loops may provide a "handle" for proteases to attach to the 20 molecule to inactivate the molecule. Modification of the loops to prevent protease degradation, yet have (via retention of the overall structure of non-modified G-CSF) no loss in biological activity may be accomplished.

25 This phenomenon is probably not limited to the G-CSF molecule but may also be common to the other molecules with known similar overall structures, as presented in Figure 2. Alteration of the external loop of, for example hGH, Interferon B, IL-2, GM-CSF and IL-4 30 may provide the least change to the overall structure. The external loops on the GM-CSF molecule are not as flexible as those found on the G-CSF molecule, and this may indicate a longer serum life, consistent with the broader biological activity of GM-CSF. Thus, the 35 external loops of GM-CSF may be modified by releasing the external loops from the beta-sheet structure, which

- 68 -

may make the loops more flexible (similar to those G-CSF) and therefore make the molecule more susceptible to protease degradation (and thus increase the turnover rate).

5 Alteration of these external loops may be effected by stabilizing the loops by connection to one or more of the internal helices. Connecting means are known to those in the art, such as the formation of a beta sheet, salt bridge, disulfide bonding or
10 hydrophobic interactions, and other means are available. Also, deletion of one or more moieties, such as one or more amino acid residues or portions thereof, to prepare an abbreviated molecule and thus eliminate certain portions of the external loops may be effected.

15 Thus, by alteration of the external loops, preferably the AB loop (amino acids 58-72 of r-hu-met G-CSF) or the CD loop (amino acids 119 to 145 of r-hu-met-G-CSF), and less preferably the amino terminus (amino acids 1-10), one may therefore modify the
20 biological function without elimination of G-CSF G-CSF receptor binding. For example, one may: (1) increase half-life (or prepare an oral dosage form, for example) of the G-CSF molecule by, for example, decreasing the ability of proteases to act on the G-CSF molecule or
25 adding chemical modifications to the G-CSF molecule, such as one or more polyethylene glycol molecules or enteric coatings for oral formulation which would act to change some characteristic of the G-CSF molecule as described above, such as increasing serum or other half-
30 life or decreasing antigenicity; (2) prepare a hybrid molecule, such as combining G-CSF with part or all of another protein such as another cytokine or another protein which effects signal transduction via entry through the cell through a G-CSF G-CSF receptor
35 transport mechanism; or (3) increase the biological activity as in, for example, the ability to selectively

- 69 -

stimulate neutrophils (as compared to a non-modified G-CSF molecule). This list is not limited to the above exemplars.

Another aspect observed from the above data is that stabilizing surface interactions may affect biological activity. This is apparent from comparing analogs 23 and 40. Analog 23 contains a substitution of the charged asparagine residue at position 28 for the neutrally-charged alanine residue in that position, and such substitution resulted in a 50% increase in the biological activity (as measured by the disclosed thymidine uptake assays). The asparagine residue at position 28 has a surface interaction with the asparagine residue at position 113; both residues being negatively charged, there is a certain amount of instability (due to the repelling of like charged moieties). When, however the asparagine at position 113 is replaced with the neutrally-charged alanine, the biological activity drops to zero (in the present assay system). This indicates that the asparagine at position 113 is critical to biological activity, and elimination of the asparagine at position 28 serves to increase the effect that asparagine at position 113 possesses.

The domains required for G-CSF receptor binding were also determined based on the above analogs prepared and the G-CSF structure. The G-CSF receptor binding domain is located at residues (with methionine being position 1) 11-57 (between the A and AB helix) and 100-118 (between the B and C helices). One may also prepare abbreviated molecules capable of binding to a G-CSF receptor and initiate signal transduction for selectively stimulating neutrophils by changing the external loop structure and having the receptor binding domains remain intact.

Residues essential for biological activity and presumably G-CSF receptor binding or signal transduction

- 70 -

have been identified. Two distinct sites are located on two different regions of the secondary structure. What is here called "Site A" is located on a helix which is constrained by salt bridge contacts between two other members of the helical bundle. The second site, "Site B" is located on a relatively more flexible helix, AB. The AB helix is potentially more sensitive to local pH changes because of the type and position of the residues at the carboxy and amino termini. The functional importance of this flexible helix may be important in a conformationally induced fit when binding to the G-CSF receptor. Additionally, the extended portion of the D helix is also indicated to be a G-CSF receptor binding domain, as ascertained by direct mutational and indirect comparative protein structure analysis. Deletion of the carboxy terminal end of r-hu-met-G-CSF reduces activity as it does for hGH, see, Cunningham and Wells, *Science* 244: 1081-1084 (1989). Cytokines which have similar structures, such as IL-6 and GM-CSF with predicted similar topology also center their biological activity along the carboxy end of the D helix, see Bazan, *Immunology Today* 11: 350-354 (1990)

A comparison of the structures and the positions of G-CSF receptor binding determinants between G-CSF and hGH suggests both molecules have similar means of signal transduction. Two separate G-CSF receptor binding sites have been identified for hGH De Vos et al., *Science* 255: 306-32 (1991). One of these binding sites (called "Site I") is formed by residues on the exposed faces of hGH's helix 1, the connection region between helix 1 and 2, and helix 4. The second binding site (called "Site II") is formed by surface residues of helix 1 and helix 3.

The G-CSF receptor binding determinates identified for G-CSF are located in the same relative positions as those identified for hGH. The G-CSF

- 71 -

receptor binding site located in the connecting region between helix A and B on the AB helix (Site A) is similar in position to that reported for a small piece of helix (residues 38-47) of hGH. A single point
5 mutation in the AB helix of G-CSF significantly reduces biological activity (as ascertained in the present assays), indicating the role in a G-CSF receptor-ligand interface. Binding of the G-CSF receptor may destabilize the 3¹⁰ helical nature of this region and
10 induce a conformation change improving the binding energy of the ligand/G-CSF receptor complex.

In the hGH receptor complex, the first helix of the bundle donates residues to both of the binding sites required to dimerize the hGH receptor. Mutational
15 analysis of the corresponding helix of G-CSF (helix A) has identified three residues which are required for biological activity. Of these three residues, Glu 20 and Arg 24 lie on one face of the helical bundle towards helix C, whereas the side chain of Arg 23 (in two of the
20 three molecules in the asymmetric unit) points to the face of the bundle towards helix D. The position of side chains of these biologically important residues indicates that similar to hGH, G-CSF may have a second G-CSF receptor binding site along the interface between
25 helix A and helix C. In contrast with the hGH molecule, the amino terminus of G-CSF has a limited biological role as deletion of the first 11 residues has little effect on the biological activity.

As indicated above (see FIGURE 2, for
30 example), G-CSF has a topological similarity with other cytokines. A correlation of the structure with previous biochemical studies, mutational analysis and direct comparison of specific residues of the hGH receptor complex indicates that G-CSF has two receptor binding
35 sites. Site A lies along the interface of the A and D helices and includes residues in the small AB helix.

- 72 -

Site B also includes residues in the A helix but lies along the interface between helices A and C. The conservation of structure and relative positions of biologically important residues between G-CSF and hGH is one indication of a common method of signal transduction in that the receptor is bound in two places. It is therefore found that G-CSF analogs possessing altered G-CSF receptor binding domains may be prepared by alteration at either of the G-CSF receptor binding sites (residues 20-57 and 145-175).

Knowledge of the three dimensional structure and correlation of the composition of G-CSF protein makes possible a systematic, rational method for preparing G-CSF analogs. The above working examples have demonstrated that the limitations of the size and polarity of the side chains within the core of the structure dictate how much change the molecule can tolerate before the overall structure is changed.

- 73 -

SEQUENCE LISTING

(1) GENERAL INFORMATION:

- (i) APPLICANT: Amgen Inc.
- (ii) TITLE OF INVENTION: G-CSF ANALOG COMPOSITIONS AND METHODS
- (iii) NUMBER OF SEQUENCES: 110
- (iv) CORRESPONDENCE ADDRESS:
 - (A) ADDRESSEE: Amgen, Inc.
 - (B) STREET: Amgen Center, 1840 DeHavilland Drive
 - (C) CITY: Thousand Oaks
 - (D) STATE: California
 - (E) COUNTRY: United States of America
 - (F) ZIP: 91320-1789
- (v) COMPUTER READABLE FORM:
 - (A) MEDIUM TYPE: Floppy disk
 - (B) COMPUTER: IBM PC compatible
 - (C) OPERATING SYSTEM: PC-DOS/MS-DOS
 - (D) SOFTWARE: PatentIn Release #1.0, Version #1.25
- (vi) CURRENT APPLICATION DATA:
 - (A) APPLICATION NUMBER:
 - (B) FILING DATE:
 - (C) CLASSIFICATION:
- (viii) ATTORNEY/AGENT INFORMATION:
 - (A) NAME: Pessin, Karol
 - (B) REGISTRATION NUMBER: 34,899
- (ix) TELECOMMUNICATION INFORMATION:
 - (A) TELEPHONE: 805/499-5725
 - (B) TELEFAX: 805/499-8011

(2) INFORMATION FOR SEQ ID NO:1:

- (i) SEQUENCE CHARACTERISTICS:
 - (A) LENGTH: 565 base pairs
 - (B) TYPE: nucleic acid
 - (C) STRANDEDNESS: single
 - (D) TOPOLOGY: linear
- (ii) MOLECULE TYPE: DNA (genomic)
- (ix) FEATURE:
 - (A) NAME/KEY: CDS
 - (B) LOCATION: 30..554

- 74 -

(xi) SEQUENCE DESCRIPTION: SEQ ID NO:1:

TCTAGAAAAA ACCAAGGAGG TAATAAATA ATG ACT CCA TTA GGT CCT GCT TCT	53
Met Thr Pro Leu Gly Pro Ala Ser	
1 5	
TCT CTG CCG CAA AGC TTT CTG CTG AAA TGT CTG GAA CAG GTT CGT AAA	101
Ser Leu Pro Gln Ser Phe Leu Leu Lys Cys Leu Glu Gln Val Arg Lys	
10 15 20	
ATC CAG GGT GAC GGT GCT GCA CTG CAA GAA AAA CTG TGC GCT ACT TAC	149
Ile Gln Gly Asp Gly Ala Ala Leu Gln Glu Lys Leu Cys Ala Thr Tyr	
25 30 35 40	
AAA CTG TGC CAT CCG GAA GAA CTG GTA CTG CTG GGT CAT TCT CTT GGG	197
Lys Leu Cys His Pro Glu Glu Leu Val Leu Leu Gly His Ser Leu Gly	
45 50 55	
ATC CCG TGG GCT CCG CTG TCT TCT TGC CCA TCT CAA GCT CTT CAG CTG	245
Ile Pro Trp Ala Pro Leu Ser Ser Cys Pro Ser Gln Ala Leu Gln Leu	
60 65 70	
GCT GGT TGT CTG TCT CAA CTG CAT TCT GGT CTG TTC CTG TAT CAG GGT	293
Ala Gly Cys Leu Ser Gln Leu His Ser Gly Leu Phe Leu Tyr Gln Gly	
75 80 85	
CTT CTG CAA GCT CTG GAA GGT ATC TCT CCG GAA CTG GGT CCG ACT CTG	341
Leu Leu Gln Ala Leu Glu Gly Ile Ser Pro Glu Leu Gly Pro Thr Leu	
90 95 100	
GAC ACT CTG CAG CTA GAT GTA GCT GAC TTT GCT ACT ACT ATT TGG CAA	389
Asp Thr Leu Gln Leu Asp Val Ala Asp Phe Ala Thr Thr Ile Trp Gln	
105 110 115 120	
CAG ATG GAA GAG CTC GGT ATG GCA CCA GCT CTG CAA CCG ACT CAA GGT	437
Gln Met Glu Glu Leu Gly Met Ala Pro Ala Leu Gln Pro Thr Gln Gly	
125 130 135	
GCT ATG CCG GCA TTC GCT TCT GCA TTC CAG CGT CGT GCA GGA GGT GTA	485
Ala Met Pro Ala Phe Ala Ser Ala Phe Gln Arg Arg Ala Gly Gly Val	
140 145 150	
CTG GTT GCT TCT CAT CTG CAA TCT TTC CTG GAA GTA TCT TAC CGT GTT	533
Leu Val Ala Ser His Leu Gln Ser Phe Leu Glu Val Ser Tyr Arg Val	
155 160 165	
CTG CGT CAT CTG GCT CAG CCG TAATAGAATT C	565
Leu Arg His Leu Ala Gln Pro	
170 175	

(2) INFORMATION FOR SEQ ID NO:2:

(i) SEQUENCE CHARACTERISTICS:

- (A) LENGTH: 175 amino acids
- (B) TYPE: amino acid
- (D) TOPOLOGY: linear

- 75 -

(ii) MOLECULE TYPE: protein

(xi) SEQUENCE DESCRIPTION: SEQ ID NO:2:

```

Met Thr Pro Leu Gly Pro Ala Ser Ser Leu Pro Gln Ser Phe Leu Leu
 1           5           10           15
Lys Cys Leu Glu Gln Val Arg Lys Ile Gln Gly Asp Gly Ala Ala Leu
           20           25           30
Gln Glu Lys Leu Cys Ala Thr Tyr Lys Leu Cys His Pro Glu Glu Leu
           35           40           45
Val Leu Leu Gly His Ser Leu Gly Ile Pro Trp Ala Pro Leu Ser Ser
           50           55           60
Cys Pro Ser Gln Ala Leu Gln Leu Ala Gly Cys Leu Ser Gln Leu His
 65           70           75           80
Ser Gly Leu Phe Leu Tyr Gln Gly Leu Leu Gln Ala Leu Glu Gly Ile
           85           90           95
Ser Pro Glu Leu Gly Pro Thr Leu Asp Thr Leu Gln Leu Asp Val Ala
           100          105          110
Asp Phe Ala Thr Thr Ile Trp Gln Gln Met Glu Glu Leu Gly Met Ala
           115          120          125
Pro Ala Leu Gln Pro Thr Gln Gly Ala Met Pro Ala Phe Ala Ser Ala
           130          135          140
Phe Gln Arg Arg Ala Gly Gly Val Leu Val Ala Ser His Leu Gln Ser
145           150          155          160
Phe Leu Glu Val Ser Tyr Arg Val Leu Arg His Leu Ala Gln Pro
           165          170          175
    
```

(2) INFORMATION FOR SEQ ID NO:3:

- (i) SEQUENCE CHARACTERISTICS:
 - (A) LENGTH: 24 base pairs
 - (B) TYPE: nucleic acid
 - (C) STRANDEDNESS: single
 - (D) TOPOLOGY: linear

(ii) MOLECULE TYPE: DNA

(xi) SEQUENCE DESCRIPTION: SEQ ID NO:3:

CTTTCTGCTG CGTTGTCTGG AACA

24

(2) INFORMATION FOR SEQ ID NO:4:

- (i) SEQUENCE CHARACTERISTICS:
 - (A) LENGTH: 23 base pairs
 - (B) TYPE: nucleic acid
 - (C) STRANDEDNESS: single

- 76 -

(D) TOPOLOGY: linear

(ii) MOLECULE TYPE: DNA

(xi) SEQUENCE DESCRIPTION: SEQ ID NO:4:

ACAGGTTTCGT CGTATCCAGG GTG

23

(2) INFORMATION FOR SEQ ID NO:5:

(i) SEQUENCE CHARACTERISTICS:

(A) LENGTH: 23 base pairs

(B) TYPE: nucleic acid

(C) STRANDEDNESS: single

(D) TOPOLOGY: linear

(ii) MOLECULE TYPE: DNA

(xi) SEQUENCE DESCRIPTION: SEQ ID NO:5:

CACTGCAAGA ACGTCTGTGC GTC

23

(2) INFORMATION FOR SEQ ID NO:6:

(i) SEQUENCE CHARACTERISTICS:

(A) LENGTH: 23 base pairs

(B) TYPE: nucleic acid

(C) STRANDEDNESS: single

(D) TOPOLOGY: linear

(ii) MOLECULE TYPE: DNA

(xi) SEQUENCE DESCRIPTION: SEQ ID NO:6:

CGCTACTTAC CGTCTGTGCC ATC

23

(2) INFORMATION FOR SEQ ID NO:7:

(i) SEQUENCE CHARACTERISTICS:

(A) LENGTH: 24 base pairs

(B) TYPE: nucleic acid

(C) STRANDEDNESS: single

(D) TOPOLOGY: linear

(ii) MOLECULE TYPE: DNA

(xi) SEQUENCE DESCRIPTION: SEQ ID NO:7:

CTTTCTGCTG CGTTGTCTGG AACA

24

(2) INFORMATION FOR SEQ ID NO:8:

(i) SEQUENCE CHARACTERISTICS:

(A) LENGTH: 23 base pairs

- 77 -

- (B) TYPE: nucleic acid
- (C) STRANDEDNESS: single
- (D) TOPOLOGY: linear

(ii) MOLECULE TYPE: DNA

(xi) SEQUENCE DESCRIPTION: SEQ ID NO:8:

ACAGGTTTCGT CGTATCCAGG GTG

23

(2) INFORMATION FOR SEQ ID NO:9:

- (i) SEQUENCE CHARACTERISTICS:
 - (A) LENGTH: 23 base pairs
 - (B) TYPE: nucleic acid
 - (C) STRANDEDNESS: single
 - (D) TOPOLOGY: linear

(ii) MOLECULE TYPE: DNA

(xi) SEQUENCE DESCRIPTION: SEQ ID NO:9:

CACTGCAAGA ACGTCTGTGC GCT

23

(2) INFORMATION FOR SEQ ID NO:10:

- (i) SEQUENCE CHARACTERISTICS:
 - (A) LENGTH: 24 base pairs
 - (B) TYPE: nucleic acid
 - (C) STRANDEDNESS: single
 - (D) TOPOLOGY: linear

(ii) MOLECULE TYPE: DNA

(xi) SEQUENCE DESCRIPTION: SEQ ID NO:10:

CTTCTGCTG CGTTGTCTGG AACA

24

(2) INFORMATION FOR SEQ ID NO:11:

- (i) SEQUENCE CHARACTERISTICS:
 - (A) LENGTH: 23 base pairs
 - (B) TYPE: nucleic acid
 - (C) STRANDEDNESS: single
 - (D) TOPOLOGY: linear

(ii) MOLECULE TYPE: DNA

(xi) SEQUENCE DESCRIPTION: SEQ ID NO:11:

ACAGGTTTCGT CGTATCCAGG GTG

23

- 78 -

(2) INFORMATION FOR SEQ ID NO:12:

- (i) SEQUENCE CHARACTERISTICS:
 - (A) LENGTH: 23 base pairs
 - (B) TYPE: nucleic acid
 - (C) STRANDEDNESS: single
 - (D) TOPOLOGY: linear

(ii) MOLECULE TYPE: DNA

(xi) SEQUENCE DESCRIPTION: SEQ ID NO:12:

CGCTACTTAC CGTCTGTCCC ATC

23

(2) INFORMATION FOR SEQ ID NO:13:

- (i) SEQUENCE CHARACTERISTICS:
 - (A) LENGTH: 24 base pairs
 - (B) TYPE: nucleic acid
 - (C) STRANDEDNESS: single
 - (D) TOPOLOGY: linear

(ii) MOLECULE TYPE: DNA

(xi) SEQUENCE DESCRIPTION: SEQ ID NO:13:

CTTTCTGCTG CGTTGTCTGG AACA

24

(2) INFORMATION FOR SEQ ID NO:14:

- (i) SEQUENCE CHARACTERISTICS:
 - (A) LENGTH: 23 base pairs
 - (B) TYPE: nucleic acid
 - (C) STRANDEDNESS: single
 - (D) TOPOLOGY: linear

(ii) MOLECULE TYPE: DNA

(xi) SEQUENCE DESCRIPTION: SEQ ID NO:14:

CACTGCAAGA ACGTCTGTGC GCT

23

(2) INFORMATION FOR SEQ ID NO:15:

- (i) SEQUENCE CHARACTERISTICS:
 - (A) LENGTH: 23 base pairs
 - (B) TYPE: nucleic acid
 - (C) STRANDEDNESS: single
 - (D) TOPOLOGY: linear

(ii) MOLECULE TYPE: DNA

- 79 -

(xi) SEQUENCE DESCRIPTION: SEQ ID NO:15:

CGCTACTTAC CGTCTGTGCC ATC

23

(2) INFORMATION FOR SEQ ID NO:16:

(i) SEQUENCE CHARACTERISTICS:

- (A) LENGTH: 23 base pairs
- (B) TYPE: nucleic acid
- (C) STRANDEDNESS: single
- (D) TOPOLOGY: linear

(ii) MOLECULE TYPE: DNA

(xi) SEQUENCE DESCRIPTION: SEQ ID NO:16:

ACAGGTTCGT CGTATCCAGG GTG

23

(2) INFORMATION FOR SEQ ID NO:17:

(i) SEQUENCE CHARACTERISTICS:

- (A) LENGTH: 23 base pairs
- (B) TYPE: nucleic acid
- (C) STRANDEDNESS: single
- (D) TOPOLOGY: linear

(ii) MOLECULE TYPE: DNA

(xi) SEQUENCE DESCRIPTION: SEQ ID NO:17:

CACTGCAAGA ACGTCTGTGC GCT

23

(2) INFORMATION FOR SEQ ID NO:18:

(i) SEQUENCE CHARACTERISTICS:

- (A) LENGTH: 23 base pairs
- (B) TYPE: nucleic acid
- (C) STRANDEDNESS: single
- (D) TOPOLOGY: linear

(ii) MOLECULE TYPE: DNA

(xi) SEQUENCE DESCRIPTION: SEQ ID NO:18:

CGCTACTTAC CGTCTGTGCC ATC

23

(2) INFORMATION FOR SEQ ID NO:19:

(i) SEQUENCE CHARACTERISTICS:

- (A) LENGTH: 24 base pairs
- (B) TYPE: nucleic acid
- (C) STRANDEDNESS: single
- (D) TOPOLOGY: linear

- 80 -

(ii) MOLECULE TYPE: DNA

(xi) SEQUENCE DESCRIPTION: SEQ ID NO:19:

CTTCTGCTG CGTTGTCTGG AACA

24

(2) INFORMATION FOR SEQ ID NO:20:

(i) SEQUENCE CHARACTERISTICS:

(A) LENGTH: 23 base pairs

(B) TYPE: nucleic acid

(C) STRANDEDNESS: single

(D) TOPOLOGY: linear

(ii) MOLECULE TYPE: DNA

(xi) SEQUENCE DESCRIPTION: SEQ ID NO:20:

ACAGGTTCTG CGTATCCAGG GTG

23

(2) INFORMATION FOR SEQ ID NO:21:

(i) SEQUENCE CHARACTERISTICS:

(A) LENGTH: 23 base pairs

(B) TYPE: nucleic acid

(C) STRANDEDNESS: single

(D) TOPOLOGY: linear

(ii) MOLECULE TYPE: DNA

(xi) SEQUENCE DESCRIPTION: SEQ ID NO:21:

CACTGCAAGA ACGTCTGTGC GCT

23

(2) INFORMATION FOR SEQ ID NO:22:

(i) SEQUENCE CHARACTERISTICS:

(A) LENGTH: 23 base pairs

(B) TYPE: nucleic acid

(C) STRANDEDNESS: single

(D) TOPOLOGY: linear

(ii) MOLECULE TYPE: DNA

(xi) SEQUENCE DESCRIPTION: SEQ ID NO:22:

CGTACTTAC CGTCTGTGCC ATC

23

(2) INFORMATION FOR SEQ ID NO:23:

(i) SEQUENCE CHARACTERISTICS:

(A) LENGTH: 23 base pairs

(B) TYPE: nucleic acid

(C) STRANDEDNESS: single

- 81 -

(D) TOPOLOGY: linear

(ii) MOLECULE TYPE: DNA

(xi) SEQUENCE DESCRIPTION: SEQ ID NO:23:

TCTGCTGAAA GCTCTGGAAC AGG

23

(2) INFORMATION FOR SEQ ID NO:24:

(i) SEQUENCE CHARACTERISTICS:

(A) LENGTH: 23 base pairs

(B) TYPE: nucleic acid

(C) STRANDEDNESS: single

(D) TOPOLOGY: linear

(ii) MOLECULE TYPE: DNA

(xi) SEQUENCE DESCRIPTION: SEQ ID NO:24:

CTTGTCCATC TGAAGCTCTT CAG

23

(2) INFORMATION FOR SEQ ID NO:25:

(i) SEQUENCE CHARACTERISTICS:

(A) LENGTH: 37 base pairs

(B) TYPE: nucleic acid

(C) STRANDEDNESS: single

(D) TOPOLOGY: linear

(ii) MOLECULE TYPE: DNA

(xi) SEQUENCE DESCRIPTION: SEQ ID NO:25:

GAAAAACTGT CCGCTACTTA CAAACTGTCC CATCCGG

37

(2) INFORMATION FOR SEQ ID NO:26:

(i) SEQUENCE CHARACTERISTICS:

(A) LENGTH: 22 base pairs

(B) TYPE: nucleic acid

(C) STRANDEDNESS: single

(D) TOPOLOGY: linear

(ii) MOLECULE TYPE: DNA

(xi) SEQUENCE DESCRIPTION: SEQ ID NO:26:

TTCGTAAAAT CGCGGGTGAC GG

22

(2) INFORMATION FOR SEQ ID NO:27:

(i) SEQUENCE CHARACTERISTICS:

(A) LENGTH: 22 base pairs

(B) TYPE: nucleic acid

- 82 -

- (C) STRANDEDNESS: single
- (D) TOPOLOGY: linear

(ii) MOLECULE TYPE: DNA

(xi) SEQUENCE DESCRIPTION: SEQ ID NO:27:

TCATCTGGCT GCGCCGTAAT AG

22

(2) INFORMATION FOR SEQ ID NO:28:

- (i) SEQUENCE CHARACTERISTICS:
 - (A) LENGTH: 22 base pairs
 - (B) TYPE: nucleic acid
 - (C) STRANDEDNESS: single
 - (D) TOPOLOGY: linear

(ii) MOLECULE TYPE: DNA

(xi) SEQUENCE DESCRIPTION: SEQ ID NO:28:

CCGTGTTCTG GTCATCTGG CT

22

(2) INFORMATION FOR SEQ ID NO:29:

- (i) SEQUENCE CHARACTERISTICS:
 - (A) LENGTH: 24 base pairs
 - (B) TYPE: nucleic acid
 - (C) STRANDEDNESS: single
 - (D) TOPOLOGY: linear

(ii) MOLECULE TYPE: DNA

(xi) SEQUENCE DESCRIPTION: SEQ ID NO:29:

GAAGTATCTT ACGCTGTTCT GCGT

24

(2) INFORMATION FOR SEQ ID NO:30:

- (i) SEQUENCE CHARACTERISTICS:
 - (A) LENGTH: 25 base pairs
 - (B) TYPE: nucleic acid
 - (C) STRANDEDNESS: single
 - (D) TOPOLOGY: linear

(ii) MOLECULE TYPE: DNA

(xi) SEQUENCE DESCRIPTION: SEQ ID NO:30:

GAAGTATCTT ACTAAGTTCT GCGTC

25

- 83 -

(2) INFORMATION FOR SEQ ID NO:31:

- (i) SEQUENCE CHARACTERISTICS:
 - (A) LENGTH: 22 base pairs
 - (B) TYPE: nucleic acid
 - (C) STRANDEDNESS: single
 - (D) TOPOLOGY: linear

(ii) MOLECULE TYPE: DNA

(xi) SEQUENCE DESCRIPTION: SEQ ID NO:31:

CGCTACTTAC GCACTGTGCC AT

22

(2) INFORMATION FOR SEQ ID NO:32:

- (i) SEQUENCE CHARACTERISTICS:
 - (A) LENGTH: 22 base pairs
 - (B) TYPE: nucleic acid
 - (C) STRANDEDNESS: single
 - (D) TOPOLOGY: linear

(ii) MOLECULE TYPE: DNA

(xi) SEQUENCE DESCRIPTION: SEQ ID NO:32:

CAAACGTGC AAGCCGGAAG AG

22

(2) INFORMATION FOR SEQ ID NO:33:

- (i) SEQUENCE CHARACTERISTICS:
 - (A) LENGTH: 22 base pairs
 - (B) TYPE: nucleic acid
 - (C) STRANDEDNESS: single
 - (D) TOPOLOGY: linear

(ii) MOLECULE TYPE: DNA

(xi) SEQUENCE DESCRIPTION: SEQ ID NO:33:

CATCCGGAAG CACTGGTACT GC

22

(2) INFORMATION FOR SEQ ID NO:34:

- (i) SEQUENCE CHARACTERISTICS:
 - (A) LENGTH: 23 base pairs
 - (B) TYPE: nucleic acid
 - (C) STRANDEDNESS: single
 - (D) TOPOLOGY: linear

(ii) MOLECULE TYPE: DNA

(xi) SEQUENCE DESCRIPTION: SEQ ID NO:34:

GGAACAGGTT GCTAAAATCC AGG

23

- 84 -

(2) INFORMATION FOR SEQ ID NO:35:

- (i) SEQUENCE CHARACTERISTICS:
 - (A) LENGTH: 25 base pairs
 - (B) TYPE: nucleic acid
 - (C) STRANDEDNESS: single
 - (D) TOPOLOGY: linear

(ii) MOLECULE TYPE: DNA

(xi) SEQUENCE DESCRIPTION: SEQ ID NO:35:

GAACAGGTTG GTGCGATCCA GGGTG

25

(2) INFORMATION FOR SEQ ID NO:36:

- (i) SEQUENCE CHARACTERISTICS:
 - (A) LENGTH: 22 base pairs
 - (B) TYPE: nucleic acid
 - (C) STRANDEDNESS: single
 - (D) TOPOLOGY: linear

(ii) MOLECULE TYPE: DNA

(xi) SEQUENCE DESCRIPTION: SEQ ID NO:36:

GAAATGTCTG GCACAGGTTG GT

22

(2) INFORMATION FOR SEQ ID NO:37:

- (i) SEQUENCE CHARACTERISTICS:
 - (A) LENGTH: 19 base pairs
 - (B) TYPE: nucleic acid
 - (C) STRANDEDNESS: single
 - (D) TOPOLOGY: linear

(ii) MOLECULE TYPE: DNA

(xi) SEQUENCE DESCRIPTION: SEQ ID NO:37:

TCCAGGGTGC CGGTGCTGC

19

(2) INFORMATION FOR SEQ ID NO:38:

- (i) SEQUENCE CHARACTERISTICS:
 - (A) LENGTH: 23 base pairs
 - (B) TYPE: nucleic acid
 - (C) STRANDEDNESS: single
 - (D) TOPOLOGY: linear

(ii) MOLECULE TYPE: DNA

(xi) SEQUENCE DESCRIPTION: SEQ ID NO:38:

AAGAGCTCGG TGAGGCACCA GCT

23

- 85 -

(2) INFORMATION FOR SEQ ID NO:39:

- (i) SEQUENCE CHARACTERISTICS:
 - (A) LENGTH: 23 base pairs
 - (B) TYPE: nucleic acid
 - (C) STRANDEDNESS: single
 - (D) TOPOLOGY: linear

(ii) MOLECULE TYPE: DNA

(xi) SEQUENCE DESCRIPTION: SEQ ID NO:39:

CTCAAGGTGC TGAGCCGGCA TTC

23

(2) INFORMATION FOR SEQ ID NO:40:

- (i) SEQUENCE CHARACTERISTICS:
 - (A) LENGTH: 20 base pairs
 - (B) TYPE: nucleic acid
 - (C) STRANDEDNESS: single
 - (D) TOPOLOGY: linear

(ii) MOLECULE TYPE: DNA

(xi) SEQUENCE DESCRIPTION: SEQ ID NO:40:

GAGCTCGGTC TGGCACCAGC

20

(2) INFORMATION FOR SEQ ID NO:41:

- (i) SEQUENCE CHARACTERISTICS:
 - (A) LENGTH: 21 base pairs
 - (B) TYPE: nucleic acid
 - (C) STRANDEDNESS: single
 - (D) TOPOLOGY: linear

(ii) MOLECULE TYPE: DNA

(xi) SEQUENCE DESCRIPTION: SEQ ID NO:41:

TCAAGGTGCT CTGCCGCAT T

21

(2) INFORMATION FOR SEQ ID NO:42:

- (i) SEQUENCE CHARACTERISTICS:
 - (A) LENGTH: 23 base pairs
 - (B) TYPE: nucleic acid
 - (C) STRANDEDNESS: single
 - (D) TOPOLOGY: linear

(ii) MOLECULE TYPE: DNA

- 86 -

(xi) SEQUENCE DESCRIPTION: SEQ ID NO:42:

TCTGCCGCAA GCCTTCTGC TGA 23

(2) INFORMATION FOR SEQ ID NO:43:

- (i) SEQUENCE CHARACTERISTICS:
 - (A) LENGTH: 24 base pairs
 - (B) TYPE: nucleic acid
 - (C) STRANDEDNESS: single
 - (D) TOPOLOGY: linear

(ii) MOLECULE TYPE: DNA

(xi) SEQUENCE DESCRIPTION: SEQ ID NO:43:

CTTCTGCTG GCATGTCTGG AACA 24

(2) INFORMATION FOR SEQ ID NO:44:

- (i) SEQUENCE CHARACTERISTICS:
 - (A) LENGTH: 24 base pairs
 - (B) TYPE: nucleic acid
 - (C) STRANDEDNESS: single
 - (D) TOPOLOGY: linear

(ii) MOLECULE TYPE: DNA

(xi) SEQUENCE DESCRIPTION: SEQ ID NO:44:

CTATTTGGCA AGCGATGGAA GAGC 24

(2) INFORMATION FOR SEQ ID NO:45:

- (i) SEQUENCE CHARACTERISTICS:
 - (A) LENGTH: 21 base pairs
 - (B) TYPE: nucleic acid
 - (C) STRANDEDNESS: single
 - (D) TOPOLOGY: linear

(ii) MOLECULE TYPE: DNA

(xi) SEQUENCE DESCRIPTION: SEQ ID NO:45:

CAGATGGAAG CGCTCGGTAT G 21

(2) INFORMATION FOR SEQ ID NO:46:

- (i) SEQUENCE CHARACTERISTICS:
 - (A) LENGTH: 20 base pairs
 - (B) TYPE: nucleic acid
 - (C) STRANDEDNESS: single
 - (D) TOPOLOGY: linear

(ii) MOLECULE TYPE: DNA

- 87 -

(xi) SEQUENCE DESCRIPTION: SEQ ID NO:46:

GAGCTCGGTC TGGCACCAGC

20

(2) INFORMATION FOR SEQ ID NO:47:

- (i) SEQUENCE CHARACTERISTICS:
 - (A) LENGTH: 21 base pairs
 - (B) TYPE: nucleic acid
 - (C) STRANDEDNESS: single
 - (D) TOPOLOGY: linear

(ii) MOLECULE TYPE: DNA

(xi) SEQUENCE DESCRIPTION: SEQ ID NO:47:

TCAAGGTGCT CTGCCGGCAT T

21

(2) INFORMATION FOR SEQ ID NO:48:

- (i) SEQUENCE CHARACTERISTICS:
 - (A) LENGTH: 22 base pairs
 - (B) TYPE: nucleic acid
 - (C) STRANDEDNESS: single
 - (D) TOPOLOGY: linear

(ii) MOLECULE TYPE: DNA

(xi) SEQUENCE DESCRIPTION: SEQ ID NO:48:

GAAATGTCTG GCACAGGTTT C

22

(2) INFORMATION FOR SEQ ID NO:49:

- (i) SEQUENCE CHARACTERISTICS:
 - (A) LENGTH: 19 base pairs
 - (B) TYPE: nucleic acid
 - (C) STRANDEDNESS: single
 - (D) TOPOLOGY: linear

(ii) MOLECULE TYPE: DNA

(xi) SEQUENCE DESCRIPTION: SEQ ID NO:49:

TTCCGGAGCG CACAGTTTG

19

(2) INFORMATION FOR SEQ ID NO:50:

- (i) SEQUENCE CHARACTERISTICS:
 - (A) LENGTH: 23 base pairs
 - (B) TYPE: nucleic acid
 - (C) STRANDEDNESS: single
 - (D) TOPOLOGY: linear

- 88 -

(ii) MOLECULE TYPE: DNA

(xi) SEQUENCE DESCRIPTION: SEQ ID NO:50:

CGAGAAGGCC TCGGGTGTCA AAC

23

(2) INFORMATION FOR SEQ ID NO:51:

(i) SEQUENCE CHARACTERISTICS:

- (A) LENGTH: 22 base pairs
- (B) TYPE: nucleic acid
- (C) STRANDEDNESS: single
- (D) TOPOLOGY: linear

(ii) MOLECULE TYPE: DNA

(xi) SEQUENCE DESCRIPTION: SEQ ID NO:51:

ATGCCAAATT GCAGTAGCAA AG

22

(2) INFORMATION FOR SEQ ID NO:52:

(i) SEQUENCE CHARACTERISTICS:

- (A) LENGTH: 24 base pairs
- (B) TYPE: nucleic acid
- (C) STRANDEDNESS: single
- (D) TOPOLOGY: linear

(ii) MOLECULE TYPE: DNA

(xi) SEQUENCE DESCRIPTION: SEQ ID NO:52:

ACAACGGTTT AACGTCATCG TTTC

24

(2) INFORMATION FOR SEQ ID NO:53:

(i) SEQUENCE CHARACTERISTICS:

- (A) LENGTH: 22 base pairs
- (B) TYPE: nucleic acid
- (C) STRANDEDNESS: single
- (D) TOPOLOGY: linear

(ii) MOLECULE TYPE: DNA

(xi) SEQUENCE DESCRIPTION: SEQ ID NO:53:

ATCAGCTACT GCTAGCTGCA GA

22

(2) INFORMATION FOR SEQ ID NO:54:

(i) SEQUENCE CHARACTERISTICS:

- (A) LENGTH: 23 base pairs
- (B) TYPE: nucleic acid
- (C) STRANDEDNESS: single
- (D) TOPOLOGY: linear

- 89 -

(ii) MOLECULE TYPE: DNA

(xi) SEQUENCE DESCRIPTION: SEQ ID NO:54:

TCAGTCGATG ACGATCGACG TCT

23

(2) INFORMATION FOR SEQ ID NO:55:

(i) SEQUENCE CHARACTERISTICS:

(A) LENGTH: 22 base pairs

(B) TYPE: nucleic acid

(C) STRANDEDNESS: single

(D) TOPOLOGY: linear

(ii) MOLECULE TYPE: DNA

(xi) SEQUENCE DESCRIPTION: SEQ ID NO:55:

TTACGAACCG CTTCCAGACA TT

22

(2) INFORMATION FOR SEQ ID NO:56:

(i) SEQUENCE CHARACTERISTICS:

(A) LENGTH: 25 base pairs

(B) TYPE: nucleic acid

(C) STRANDEDNESS: single

(D) TOPOLOGY: linear

(ii) MOLECULE TYPE: DNA

(xi) SEQUENCE DESCRIPTION: SEQ ID NO:56:

TAAAATGCTT GCGAAGGTC TGTA

25

(2) INFORMATION FOR SEQ ID NO:57:

(i) SEQUENCE CHARACTERISTICS:

(A) LENGTH: 22 base pairs

(B) TYPE: nucleic acid

(C) STRANDEDNESS: single

(D) TOPOLOGY: linear

(ii) MOLECULE TYPE: DNA

(xi) SEQUENCE DESCRIPTION: SEQ ID NO:57:

GTAGCAAATG CAGCTACATC TA

22

(2) INFORMATION FOR SEQ ID NO:58:

(i) SEQUENCE CHARACTERISTICS:

(A) LENGTH: 25 base pairs

(B) TYPE: nucleic acid

- 90 -

- (C) STRANDEDNESS: single
- (D) TOPOLOGY: linear

(ii) MOLECULE TYPE: DNA

(xi) SEQUENCE DESCRIPTION: SEQ ID NO:58:

CATCATCGTT TACGTCGATG TAGAT

25

(2) INFORMATION FOR SEQ ID NO:59:

- (i) SEQUENCE CHARACTERISTICS:
 - (A) LENGTH: 20 base pairs
 - (B) TYPE: nucleic acid
 - (C) STRANDEDNESS: single
 - (D) TOPOLOGY: linear

(ii) MOLECULE TYPE: DNA

(xi) SEQUENCE DESCRIPTION: SEQ ID NO:59:

CCAAGAGAAG CACCCAGCAG

20

(2) INFORMATION FOR SEQ ID NO:60:

- (i) SEQUENCE CHARACTERISTICS:
 - (A) LENGTH: 22 base pairs
 - (B) TYPE: nucleic acid
 - (C) STRANDEDNESS: single
 - (D) TOPOLOGY: linear

(ii) MOLECULE TYPE: DNA

(xi) SEQUENCE DESCRIPTION: SEQ ID NO:60:

AGGGTTCTCT TCGTGGGTCG TC

22

(2) INFORMATION FOR SEQ ID NO:61:

- (i) SEQUENCE CHARACTERISTICS:
 - (A) LENGTH: 20 base pairs
 - (B) TYPE: nucleic acid
 - (C) STRANDEDNESS: single
 - (D) TOPOLOGY: linear

(ii) MOLECULE TYPE: DNA

(xi) SEQUENCE DESCRIPTION: SEQ ID NO:61:

CACTGGCGGT GATAATGAGC

20

- 91 -

(2) INFORMATION FOR SEQ ID NO:62:

- (i) SEQUENCE CHARACTERISTICS:
 - (A) LENGTH: 19 base pairs
 - (B) TYPE: nucleic acid
 - (C) STRANDEDNESS: single
 - (D) TOPOLOGY: linear

(ii) MOLECULE TYPE: DNA

(xi) SEQUENCE DESCRIPTION: SEQ ID NO:62:

CTAGGCCAGG CATTACTGG

19

(2) INFORMATION FOR SEQ ID NO:63:

- (i) SEQUENCE CHARACTERISTICS:
 - (A) LENGTH: 21 base pairs
 - (B) TYPE: nucleic acid
 - (C) STRANDEDNESS: single
 - (D) TOPOLOGY: linear

(ii) MOLECULE TYPE: DNA

(xi) SEQUENCE DESCRIPTION: SEQ ID NO:63:

CCACTGGCGG TGATACTGAG C

21

(2) INFORMATION FOR SEQ ID NO:64:

- (i) SEQUENCE CHARACTERISTICS:
 - (A) LENGTH: 33 base pairs
 - (B) TYPE: nucleic acid
 - (C) STRANDEDNESS: single
 - (D) TOPOLOGY: linear

(ii) MOLECULE TYPE: DNA

(xi) SEQUENCE DESCRIPTION: SEQ ID NO:64:

AGCAGAAAGC TTTCCGGCAG AGAAGAAGCA GGA

33

(2) INFORMATION FOR SEQ ID NO:65:

- (i) SEQUENCE CHARACTERISTICS:
 - (A) LENGTH: 54 base pairs
 - (B) TYPE: nucleic acid
 - (C) STRANDEDNESS: single
 - (D) TOPOLOGY: linear

(ii) MOLECULE TYPE: DNA

(xi) SEQUENCE DESCRIPTION: SEQ ID NO:65:

GCCGCAAAGC TTTCTGCTGA AATGTCTGGA AGAGGTTCGT AAAATCCAGG GTGA

54

- 92 -

(2) INFORMATION FOR SEQ ID NO:66:

- (i) SEQUENCE CHARACTERISTICS:
 (A) LENGTH: 59 base pairs
 (B) TYPE: nucleic acid
 (C) STRANDEDNESS: single
 (D) TOPOLOGY: linear

(ii) MOLECULE TYPE: DNA

(xi) SEQUENCE DESCRIPTION: SEQ ID NO:66:

CTGGAATGCA GAAGCAAATG CCGGCATAGC ACCTTCAGTC GGTTCAGAG CTGGTGCCA 59

(2) INFORMATION FOR SEQ ID NO:67:

- (i) SEQUENCE CHARACTERISTICS:
 (A) LENGTH: 175 amino acids
 (B) TYPE: amino acid
 (D) TOPOLOGY: linear

(ii) MOLECULE TYPE: protein

(xi) SEQUENCE DESCRIPTION: SEQ ID NO:67:

Met Thr Pro Leu Gly Pro Ala Ser Ser Leu Pro Gln Ser Phe Leu Leu
 1 5 10 15

Arg Cys Leu Glu Gln Val Arg Lys Ile Gln Gly Asp Gly Ala Ala Leu
 20 25 30

Gln Glu Lys Leu Cys Ala Thr Tyr Lys Leu Cys His Pro Glu Glu Leu
 35 40 45

Val Leu Leu Gly His Ser Leu Gly Ile Pro Trp Ala Pro Leu Ser Ser
 50 55 60

Cys Pro Ser Gln Ala Leu Gln Leu Ala Gly Cys Leu Ser Gln Leu His
 65 70 75 80

Ser Gly Leu Phe Leu Tyr Gln Gly Leu Leu Gln Ala Leu Glu Gly Ile
 85 90 95

Ser Pro Glu Leu Gly Pro Thr Leu Asp Thr Leu Gln Leu Asp Val Ala
 100 105 110

Asp Phe Ala Thr Thr Ile Trp Gln Gln Met Glu Glu Leu Gly Met Ala
 115 120 125

Pro Ala Leu Gln Pro Thr Gln Gly Ala Met Pro Ala Phe Ala Ser Ala
 130 135 140

Phe Gln Arg Arg Ala Gly Gly Val Leu Val Ala Ser His Leu Gln Ser
 145 150 155 160

Phe Leu Glu Val Ser Tyr Arg Val Leu Arg His Leu Ala Gln Pro
 165 170 175

- 93 -

(2) INFORMATION FOR SEQ ID NO:68:

(i) SEQUENCE CHARACTERISTICS:

(A) LENGTH: 175 amino acids

(B) TYPE: amino acid

(D) TOPOLOGY: linear

(ii) MOLECULE TYPE: protein

(xi) SEQUENCE DESCRIPTION: SEQ ID NO:68:

```

Met Thr Pro Leu Gly Pro Ala Ser Ser Leu Pro Gln Ser Phe Leu Leu
 1           5           10           15
Lys Cys Leu Glu Gln Val Arg Arg Ile Gln Gly Asp Gly Ala Ala Leu
           20           25           30
Gln Glu Lys Leu Cys Ala Thr Tyr Lys Leu Cys His Pro Glu Glu Leu
           35           40           45
Val Leu Leu Gly His Ser Leu Gly Ile Pro Trp Ala Pro Leu Ser Ser
           50           55           60
Cys Pro Ser Gln Ala Leu Gln Leu Ala Gly Cys Leu Ser Gln Leu His
           65           70           75           80
Ser Gly Leu Phe Leu Tyr Gln Gly Leu Leu Gln Ala Leu Glu Gly Ile
           85           90           95
Ser Pro Glu Leu Gly Pro Thr Leu Asp Thr Leu Gln Leu Asp Val Ala
           100          105          110
Asp Phe Ala Thr Thr Ile Trp Gln Gln Met Glu Glu Leu Gly Met Ala
           115          120          125
Pro Ala Leu Gln Pro Thr Gln Gly Ala Met Pro Ala Phe Ala Ser Ala
           130          135          140
Phe Gln Arg Arg Ala Gly Gly Val Leu Val Ala Ser His Leu Gln Ser
           145          150          155          160
Phe Leu Glu Val Ser Tyr Arg Val Leu Arg His Leu Ala Gln Pro
           165          170          175

```

(2) INFORMATION FOR SEQ ID NO:69:

(i) SEQUENCE CHARACTERISTICS:

(A) LENGTH: 175 amino acids

(B) TYPE: amino acid

(D) TOPOLOGY: linear

(ii) MOLECULE TYPE: protein

- 94 -

(xi) SEQUENCE DESCRIPTION: SEQ ID NO:69:

Met Thr Pro Leu Gly Pro Ala Ser Ser Leu Pro Gln Ser Phe Leu Leu
 1 5 10 15

Lys Cys Leu Glu Gln Val Arg Lys Ile Gln Gly Asp Gly Ala Ala Leu
 20 25 30

Gln Glu Arg Leu Cys Ala Thr Tyr Lys Leu Cys His Pro Glu Glu Leu
 35 40 45

Val Leu Leu Gly His Ser Leu Gly Ile Pro Trp Ala Pro Leu Ser Ser
 50 55 60

Cys Pro Ser Gln Ala Leu Gln Leu Ala Gly Cys Leu Ser Gln Leu His
 65 70 75 80

Ser Gly Leu Phe Leu Tyr Gln Gly Leu Leu Gln Ala Leu Glu Gly Ile
 85 90 95

Ser Pro Glu Leu Gly Pro Thr Leu Asp Thr Leu Gln Leu Asp Val Ala
 100 105 110

Asp Phe Ala Thr Thr Ile Trp Gln Gln Met Glu Glu Leu Gly Met Ala
 115 120 125

Pro Ala Leu Gln Pro Thr Gln Gly Ala Met Pro Ala Phe Ala Ser Ala
 130 135 140

Phe Gln Arg Arg Ala Gly Gly Val Leu Val Ala Ser His Leu Gln Ser
 145 150 155 160

Phe Leu Glu Val Ser Tyr Arg Val Leu Arg His Leu Ala Gln Pro
 165 170 175

(2) INFORMATION FOR SEQ ID NO:70:

(i) SEQUENCE CHARACTERISTICS:

- (A) LENGTH: 175 amino acids
 (B) TYPE: amino acid
 (D) TOPOLOGY: linear

(ii) MOLECULE TYPE: protein

(xi) SEQUENCE DESCRIPTION: SEQ ID NO:70:

Met Thr Pro Leu Gly Pro Ala Ser Ser Leu Pro Gln Ser Phe Leu Leu
 1 5 10 15

Lys Cys Leu Glu Gln Val Arg Lys Ile Gln Gly Asp Gly Ala Ala Leu
 20 25 30

Gln Glu Lys Leu Cys Ala Thr Tyr Arg Leu Cys His Pro Glu Glu Leu
 35 40 45

Val Leu Leu Gly His Ser Leu Gly Ile Pro Trp Ala Pro Leu Ser Ser
 50 55 60

- 95 -

Cys Pro Ser Gln Ala Leu Gln Leu Ala Gly Cys Leu Ser Gln Leu His
 65 70 75 80
 Ser Gly Leu Phe Leu Tyr Gln Gly Leu Leu Gln Ala Leu Glu Gly Ile
 85 90 95
 Ser Pro Glu Leu Gly Pro Thr Leu Asp Thr Leu Gln Leu Asp Val Ala
 100 105 110
 Asp Phe Ala Thr Thr Ile Trp Gln Gln Met Glu Glu Leu Gly Met Ala
 115 120 125
 Pro Ala Leu Gln Pro Thr Gln Gly Ala Met Pro Ala Phe Ala Ser Ala
 130 135 140
 Phe Gln Arg Arg Ala Gly Gly Val Leu Val Ala Ser His Leu Gln Ser
 145 150 155 160
 Phe Leu Glu Val Ser Tyr Arg Val Leu Arg His Leu Ala Gln Pro
 165 170 175

(2) INFORMATION FOR SEQ ID NO:71:

(i) SEQUENCE CHARACTERISTICS:

- (A) LENGTH: 175 amino acids
- (B) TYPE: amino acid
- (D) TOPOLOGY: linear

(ii) MOLECULE TYPE: protein

(xi) SEQUENCE DESCRIPTION: SEQ ID NO:71:

Met Thr Pro Leu Gly Pro Ala Ser Ser Leu Pro Gln Ser Phe Leu Leu
 1 5 10 15
 Arg Cys Leu Glu Gln Val Arg Arg Ile Gln Gly Asp Gly Ala Ala Leu
 20 25 30
 Gln Glu Arg Leu Cys Ala Thr Tyr Lys Leu Cys His Pro Glu Glu Leu
 35 40 45
 Val Leu Leu Gly His Ser Leu Gly Ile Pro Trp Ala Pro Leu Ser Ser
 50 55 60
 Cys Pro Ser Gln Ala Leu Gln Leu Ala Gly Cys Leu Ser Gln Leu His
 65 70 75 80
 Ser Gly Leu Phe Leu Tyr Gln Gly Leu Leu Gln Ala Leu Glu Gly Ile
 85 90 95
 Ser Pro Glu Leu Gly Pro Thr Leu Asp Thr Leu Gln Leu Asp Val Ala
 100 105 110
 Asp Phe Ala Thr Thr Ile Trp Gln Gln Met Glu Glu Leu Gly Met Ala
 115 120 125

- 96 -

Pro Ala Leu Gln Pro Thr Gln Gly Ala Met Pro Ala Phe Ala Ser Ala
 130 135 140

Phe Gln Arg Arg Ala Gly Gly Val Leu Val Ala Ser His Leu Gln Ser
 145 150 155 160

Phe Leu Glu Val Ser Tyr Arg Val Leu Arg His Leu Ala Gln Pro
 165 170 175

(2) INFORMATION FOR SEQ ID NO:72:

- (i) SEQUENCE CHARACTERISTICS:
 - (A) LENGTH: 175 amino acids
 - (B) TYPE: amino acid
 - (D) TOPOLOGY: linear

(ii) MOLECULE TYPE: protein

(xi) SEQUENCE DESCRIPTION: SEQ ID NO:72:

Met Thr Pro Leu Gly Pro Ala Ser Ser Leu Pro Gln Ser Phe Leu Leu
 1 5 10 15

Arg Cys Leu Glu Gln Val Arg Lys Ile Gln Gly Asp Gly Ala Ala Leu
 20 25 30

Gln Glu Arg Leu Cys Ala Thr Tyr Arg Leu Cys His Pro Glu Glu Leu
 35 40 45

Val Leu Leu Gly His Ser Leu Gly Ile Pro Trp Ala Pro Leu Ser Ser
 50 55 60

Cys Pro Ser Gln Ala Leu Gln Leu Ala Gly Cys Leu Ser Gln Leu His
 65 70 75 80

Ser Gly Leu Phe Leu Tyr Gln Gly Leu Leu Gln Ala Leu Glu Gly Ile
 85 90 95

Ser Pro Glu Leu Gly Pro Thr Leu Asp Thr Leu Gln Leu Asp Val Ala
 100 105 110

Asp Phe Ala Thr Thr Ile Trp Gln Gln Met Glu Glu Leu Gly Met Ala
 115 120 125

Pro Ala Leu Gln Pro Thr Gln Gly Ala Met Pro Ala Phe Ala Ser Ala
 130 135 140

Phe Gln Arg Arg Ala Gly Gly Val Leu Val Ala Ser His Leu Gln Ser
 145 150 155 160

Phe Leu Glu Val Ser Tyr Arg Val Leu Arg His Leu Ala Gln Pro
 165 170 175

- 97 -

(2) INFORMATION FOR SEQ ID NO:73:

(i) SEQUENCE CHARACTERISTICS:

(A) LENGTH: 175 amino acids

(B) TYPE: amino acid

(D) TOPOLOGY: linear

(ii) MOLECULE TYPE: protein

(xi) SEQUENCE DESCRIPTION: SEQ ID NO:73:

```

Met Thr Pro Leu Gly Pro Ala Ser Ser Leu Pro Gln Ser Phe Leu Leu
 1           5           10           15

Lys Cys Leu Glu Gln Val Arg Arg Ile Gln Gly Asp Gly Ala Ala Leu
           20           25           30

Gln Glu Arg Leu Cys Ala Thr Tyr Arg Leu Cys His Pro Glu Glu Leu
           35           40           45

Val Leu Leu Gly His Ser Leu Gly Ile Pro Trp Ala Pro Leu Ser Ser
 50           55           60

Cys Pro Ser Gln Ala Leu Gln Leu Ala Gly Cys Leu Ser Gln Leu His
 65           70           75           80

Ser Gly Leu Phe Leu Tyr Gln Gly Leu Leu Gln Ala Leu Glu Gly Ile
           85           90           95

Ser Pro Glu Leu Gly Pro Thr Leu Asp Thr Leu Gln Leu Asp Val Ala
           100           105           110

Asp Phe Ala Thr Thr Ile Trp Gln Gln Met Glu Glu Leu Gly Met Ala
           115           120           125

Pro Ala Leu Gln Pro Thr Gln Gly Ala Met Pro Ala Phe Ala Ser Ala
           130           135           140

Phe Gln Arg Arg Ala Gly Gly Val Leu Val Ala Ser His Leu Gln Ser
           145           150           155           160

Phe Leu Glu Val Ser Tyr Arg Val Leu Arg His Leu Ala Gln Pro
           165           170           175

```

(2) INFORMATION FOR SEQ ID NO:74:

(i) SEQUENCE CHARACTERISTICS:

(A) LENGTH: 175 amino acids

(B) TYPE: amino acid

(D) TOPOLOGY: linear

(ii) MOLECULE TYPE: protein

- 98 -

(xi) SEQUENCE DESCRIPTION: SEQ ID NO:74:

Met Thr Pro Leu Gly Pro Ala Ser Ser Leu Pro Gln Ser Phe Leu Leu
 1 5 10 15

Arg Cys Leu Glu Gln Val Arg Arg Ile Gln Gly Asp Gly Ala Ala Leu
 20 25 30

Gln Glu Arg Leu Cys Ala Thr Tyr Arg Leu Cys His Pro Glu Glu Leu
 35 40 45

Val Leu Leu Gly His Ser Leu Gly Ile Pro Trp Ala Pro Leu Ser Ser
 50 55 60

Cys Pro Ser Gln Ala Leu Gln Leu Ala Gly Cys Leu Ser Gln Leu His
 65 70 75 80

Ser Gly Leu Phe Leu Tyr Gln Gly Leu Leu Gln Ala Leu Glu Gly Ile
 85 90 95

Ser Pro Glu Leu Gly Pro Thr Leu Asp Thr Leu Gln Leu Asp Val Ala
 100 105 110

Asp Phe Ala Thr Thr Ile Trp Gln Gln Met Glu Glu Leu Gly Met Ala
 115 120 125

Pro Ala Leu Gln Pro Thr Gln Gly Ala Met Pro Ala Phe Ala Ser Ala
 130 135 140

Phe Gln Arg Arg Ala Gly Gly Val Leu Val Ala Ser His Leu Gln Ser
 145 150 155 160

Phe Leu Glu Val Ser Tyr Arg Val Leu Arg His Leu Ala Gln Pro
 165 170 175

(2) INFORMATION FOR SEQ ID NO:75:

(i) SEQUENCE CHARACTERISTICS:

- (A) LENGTH: 175 amino acids
- (B) TYPE: amino acid
- (D) TOPOLOGY: linear

(ii) MOLECULE TYPE: protein

(xi) SEQUENCE DESCRIPTION: SEQ ID NO:75:

Met Thr Pro Leu Gly Pro Ala Ser Ser Leu Pro Gln Ser Phe Leu Leu
 1 5 10 15

Arg Cys Leu Glu Gln Val Arg Arg Ile Gln Gly Asp Gly Ala Ala Leu
 20 25 30

Gln Glu Lys Leu Cys Ala Thr Tyr Arg Leu Cys His Pro Glu Glu Leu
 35 40 45

- 99 -

Val Leu Leu Gly His Ser Leu Gly Ile Pro Trp Ala Pro Leu Ser Ser
50 55 60

Cys Pro Ser Gln Ala Leu Gln Leu Ala Gly Cys Leu Ser Gln Leu His
65 70 75 80

Ser Gly Leu Phe Leu Tyr Gln Gly Leu Leu Gln Ala Leu Glu Gly Ile
85 90 95

Ser Pro Glu Leu Gly Pro Thr Leu Asp Thr Leu Gln Leu Asp Val Ala
100 105 110

Asp Phe Ala Thr Thr Ile Trp Gln Gln Met Glu Glu Leu Gly Met Ala
115 120 125

Pro Ala Leu Gln Pro Thr Gln Gly Ala Met Pro Ala Phe Ala Ser Ala
130 135 140

Phe Gln Arg Arg Ala Gly Gly Val Leu Val Ala Ser His Leu Gln Ser
145 150 155 160

Phe Leu Glu Val Ser Tyr Arg Val Leu Arg His Leu Ala Gln Pro
165 170 175

(2) INFORMATION FOR SEQ ID NO:76:

(i) SEQUENCE CHARACTERISTICS:

(A) LENGTH: 175 amino acids

(B) TYPE: amino acid

(D) TOPOLOGY: linear

(ii) MOLECULE TYPE: protein

(xi) SEQUENCE DESCRIPTION: SEQ ID NO:76:

Met Thr Pro Leu Gly Pro Ala Ser Ser Leu Pro Gln Ser Phe Leu Leu
1 5 10 15

Lys Cys Leu Glu Gln Val Arg Lys Ile Gln Gly Asp Gly Ala Ala Leu
20 25 30

Gln Glu Lys Leu Cys Ala Thr Tyr Lys Leu Cys His Pro Glu Glu Leu
35 40 45

Val Leu Leu Gly His Ser Leu Gly Ile Pro Trp Ala Pro Leu Ser Ser
50 55 60

Cys Pro Ser Glu Ala Leu Gln Leu Ala Gly Cys Leu Ser Gln Leu His
65 70 75 80

Ser Gly Leu Phe Leu Tyr Gln Gly Leu Leu Gln Ala Leu Glu Gly Ile
85 90 95

Ser Pro Glu Leu Gly Pro Thr Leu Asp Thr Leu Gln Leu Asp Val Ala
100 105 110

Asp Phe Ala Thr Thr Ile Trp Gln Gln Met Glu Glu Leu Gly Met Ala

- 100 -

115	120	125
Pro Ala Leu Gln Pro Thr Gln Gly Ala Met Pro Ala Phe Ala Ser Ala		
130	135	140
Phe Gln Arg Arg Ala Gly Gly Val Leu Val Ala Ser His Leu Gln Ser		
145	150	155
Phe Leu Glu Val Ser Tyr Arg Val Leu Arg His Leu Ala Gln Pro		
165	170	175

(2) INFORMATION FOR SEQ ID NO:77:

(i) SEQUENCE CHARACTERISTICS:

- (A) LENGTH: 175 amino acids
- (B) TYPE: amino acid
- (D) TOPOLOGY: linear

(ii) MOLECULE TYPE: protein

(xi) SEQUENCE DESCRIPTION: SEQ ID NO:77:

Met Thr Pro Leu Gly Pro Ala Ser Ser Leu Pro Gln Ser Phe Leu Leu		
1	5	10
Lys Cys Leu Glu Gln Val Arg Lys Ile Gln Gly Asp Gly Ala Ala Leu		
20	25	30
Gln Glu Lys Leu Ser Ala Thr Tyr Lys Leu Ser His Pro Glu Glu Leu		
35	40	45
Val Leu Leu Gly His Ser Leu Gly Ile Pro Trp Ala Pro Leu Ser Ser		
50	55	60
Cys Pro Ser Gln Ala Leu Gln Leu Ala Gly Cys Leu Ser Gln Leu His		
65	70	75
Ser Gly Leu Phe Leu Tyr Gln Gly Leu Leu Gln Ala Leu Glu Gly Ile		
85	90	95
Ser Pro Glu Leu Gly Pro Thr Leu Asp Thr Leu Gln Leu Asp Val Ala		
100	105	110
Asp Phe Ala Thr Thr Ile Trp Gln Gln Met Glu Glu Leu Gly Met Ala		
115	120	125
Pro Ala Leu Gln Pro Thr Gln Gly Ala Met Pro Ala Phe Ala Ser Ala		
130	135	140
Phe Gln Arg Arg Ala Gly Gly Val Leu Val Ala Ser His Leu Gln Ser		
145	150	155
Phe Leu Glu Val Ser Tyr Arg Val Leu Arg His Leu Ala Gln Pro		
165	170	175

- 101 -

(2) INFORMATION FOR SEQ ID NO:78:

(i) SEQUENCE CHARACTERISTICS:

- (A) LENGTH: 175 amino acids
- (B) TYPE: amino acid
- (D) TOPOLOGY: linear

(ii) MOLECULE TYPE: protein

(xi) SEQUENCE DESCRIPTION: SEQ ID NO:78:

```

Met Thr Pro Leu Gly Pro Ala Ser Ser Leu Pro Gln Ser Phe Leu Leu
 1           5           10           15

Lys Cys Leu Glu Gln Val Arg Lys Ile Ala Gly Asp Gly Ala Ala Leu
           20           25           30

Gln Glu Lys Leu Cys Ala Thr Tyr Lys Leu Cys His Pro Glu Glu Leu
           35           40           45

Val Leu Leu Gly His Ser Leu Gly Ile Pro Trp Ala Pro Leu Ser Ser
 50           55           60

Cys Pro Ser Gln Ala Leu Gln Leu Ala Gly Cys Leu Ser Gln Leu His
 65           70           75           80

Ser Gly Leu Phe Leu Tyr Gln Gly Leu Leu Gln Ala Leu Glu Gly Ile
           85           90           95

Ser Pro Glu Leu Gly Pro Thr Leu Asp Thr Leu Gln Leu Asp Val Ala
           100          105          110

Asp Phe Ala Thr Thr Ile Trp Gln Gln Met Glu Glu Leu Gly Met Ala
           115          120          125

Pro Ala Leu Gln Pro Thr Gln Gly Ala Met Pro Ala Phe Ala Ser Ala
           130          135          140

Phe Gln Arg Arg Ala Gly Gly Val Leu Val Ala Ser His Leu Gln Ser
145           150          155          160

Phe Leu Glu Val Ser Tyr Arg Val Leu Arg His Leu Ala Gln Pro
           165          170          175
    
```

(2) INFORMATION FOR SEQ ID NO:79:

(i) SEQUENCE CHARACTERISTICS:

- (A) LENGTH: 175 amino acids
- (B) TYPE: amino acid
- (D) TOPOLOGY: linear

(ii) MOLECULE TYPE: protein

(xi) SEQUENCE DESCRIPTION: SEQ ID NO:79:

```

Met Thr Pro Leu Gly Pro Ala Ser Ser Leu Pro Gln Ser Phe Leu Leu
 1           5           10           15
    
```

- 102 -

Lys Cys Leu Glu Gln Val Arg Lys Ile Gln Gly Asp Gly Ala Ala Leu
 20 25 30

Gln Glu Lys Leu Cys Ala Thr Tyr Lys Leu Cys His Pro Glu Glu Leu
 35 40 45

Val Leu Leu Gly His Ser Leu Gly Ile Pro Trp Ala Pro Leu Ser Ser
 50 55 60

Cys Pro Ser Gln Ala Leu Gln Leu Ala Gly Cys Leu Ser Gln Leu His
 65 70 75 80

Ser Gly Leu Phe Leu Tyr Gln Gly Leu Leu Gln Ala Leu Glu Gly Ile
 85 90 95

Ser Pro Glu Leu Gly Pro Thr Leu Asp Thr Leu Gln Leu Asp Val Ala
 100 105 110

Asp Phe Ala Thr Thr Ile Trp Gln Gln Met Glu Glu Leu Gly Met Ala
 115 120 125

Pro Ala Leu Gln Pro Thr Gln Gly Ala Met Pro Ala Phe Ala Ser Ala
 130 135 140

Phe Gln Arg Arg Ala Gly Gly Val Leu Val Ala Ser His Leu Gln Ser
 145 150 155 160

Phe Leu Glu Val Ser Tyr Arg Val Leu Arg His Leu Ala Ala Pro
 165 170 175

(2) INFORMATION FOR SEQ ID NO:80:

(i) SEQUENCE CHARACTERISTICS:

- (A) LENGTH: 175 amino acids
- (B) TYPE: amino acid
- (D) TOPOLOGY: linear

(ii) MOLECULE TYPE: protein

(xi) SEQUENCE DESCRIPTION: SEQ ID NO:80:

Met Thr Pro Leu Gly Pro Ala Ser Ser Leu Pro Gln Ser Phe Leu Leu
 1 5 10 15

Lys Cys Leu Glu Gln Val Arg Lys Ile Gln Gly Asp Gly Ala Ala Leu
 20 25 30

Gln Glu Lys Leu Cys Ala Thr Tyr Lys Leu Cys His Pro Glu Glu Leu
 35 40 45

Val Leu Leu Gly His Ser Leu Gly Ile Pro Trp Ala Pro Leu Ser Ser
 50 55 60

Cys Pro Ser Gln Ala Leu Gln Leu Ala Gly Cys Leu Ser Gln Leu His
 65 70 75 80

- 103 -

Ser Gly Leu Phe Leu Tyr Gln Gly Leu Leu Gln Ala Leu Glu Gly Ile
 85 90 95

Ser Pro Glu Leu Gly Pro Thr Leu Asp Thr Leu Gln Leu Asp Val Ala
 100 105 110

Asp Phe Ala Thr Thr Ile Trp Gln Gln Met Glu Glu Leu Gly Met Ala
 115 120 125

Pro Ala Leu Gln Pro Thr Gln Gly Ala Met Pro Ala Phe Ala Ser Ala
 130 135 140

Phe Gln Arg Arg Ala Gly Gly Val Leu Val Ala Ser His Leu Gln Ser
 145 150 155 160

Phe Leu Glu Val Ser Tyr Arg Val Leu Ala His Leu Ala Gln Pro
 165 170 175

(2) INFORMATION FOR SEQ ID NO:81:

(i) SEQUENCE CHARACTERISTICS:

- (A) LENGTH: 175 amino acids
- (B) TYPE: amino acid
- (D) TOPOLOGY: linear

(ii) MOLECULE TYPE: protein

(xi) SEQUENCE DESCRIPTION: SEQ ID NO:81:

Met Thr Pro Leu Gly Pro Ala Ser Ser Leu Pro Gln Ser Phe Leu Leu
 1 5 10 15

Lys Cys Leu Glu Gln Val Arg Lys Ile Gln Gly Asp Gly Ala Ala Leu
 20 25 30

Gln Glu Lys Leu Cys Ala Thr Tyr Lys Leu Cys His Pro Glu Glu Leu
 35 40 45

Val Leu Leu Gly His Ser Leu Gly Ile Pro Trp Ala Pro Leu Ser Ser
 50 55 60

Cys Pro Ser Gln Ala Leu Gln Leu Ala Gly Cys Leu Ser Gln Leu His
 65 70 75 80

Ser Gly Leu Phe Leu Tyr Gln Gly Leu Leu Gln Ala Leu Glu Gly Ile
 85 90 95

Ser Pro Glu Leu Gly Pro Thr Leu Asp Thr Leu Gln Leu Asp Val Ala
 100 105 110

Asp Phe Ala Thr Thr Ile Trp Gln Gln Met Glu Glu Leu Gly Met Ala
 115 120 125

Pro Ala Leu Gln Pro Thr Gln Gly Ala Met Pro Ala Phe Ala Ser Ala
 130 135 140

- 104 -

Phe Gln Arg Arg Ala Gly Gly Val Leu Val Ala Ser His Leu Gln Ser
 145 150 155 160

Phe Leu Glu Val Ser Tyr Ala Val Leu Arg His Leu Ala Gln Pro
 165 170 175

(2) INFORMATION FOR SEQ ID NO:82:

- (i) SEQUENCE CHARACTERISTICS:
 - (A) LENGTH: 174 amino acids
 - (B) TYPE: amino acid
 - (D) TOPOLOGY: linear

(ii) MOLECULE TYPE: protein

(xi) SEQUENCE DESCRIPTION: SEQ ID NO:82:

Met Thr Pro Leu Gly Pro Ala Ser Ser Leu Pro Gln Ser Phe Leu Leu
 1 5 10 15

Lys Cys Leu Glu Gln Val Arg Lys Ile Gln Gly Asp Gly Ala Ala Leu
 20 25 30

Gln Glu Lys Leu Cys Ala Thr Tyr Lys Leu Cys His Pro Glu Glu Leu
 35 40 45

Val Leu Leu Gly His Ser Leu Gly Ile Pro Trp Ala Pro Leu Ser Ser
 50 55 60

Cys Pro Ser Gln Ala Leu Gln Leu Ala Gly Cys Leu Ser Gln Leu His
 65 70 75 80

Ser Gly Leu Phe Leu Tyr Gln Gly Leu Leu Gln Ala Leu Glu Gly Ile
 85 90 95

Ser Pro Glu Leu Gly Pro Thr Leu Asp Thr Leu Gln Leu Asp Val Ala
 100 105 110

Asp Phe Ala Thr Thr Ile Trp Gln Gln Met Glu Glu Leu Gly Met Ala
 115 120 125

Pro Ala Leu Gln Pro Thr Gln Gly Ala Met Pro Ala Phe Ala Ser Ala
 130 135 140

Phe Gln Arg Arg Ala Gly Gly Val Leu Val Ala Ser His Leu Gln Ser
 145 150 155 160

Phe Leu Glu Val Ser Tyr Val Leu Arg His Leu Ala Gln Pro
 165 170 174

(2) INFORMATION FOR SEQ ID NO:83:

- (i) SEQUENCE CHARACTERISTICS:
 - (A) LENGTH: 175 amino acids
 - (B) TYPE: amino acid
 - (D) TOPOLOGY: linear

- 105 -

(ii) MOLECULE TYPE: protein

(xi) SEQUENCE DESCRIPTION: SEQ ID NO:83:

Met Thr Pro Leu Gly Pro Ala Ser Ser Leu Pro Gln Ser Phe Leu Leu
 1 5 10 15

Lys Cys Leu Glu Gln Val Arg Lys Ile Gln Gly Asp Gly Ala Ala Leu
 20 25 30

Gln Glu Lys Leu Cys Ala Thr Tyr Ala Leu Cys His Pro Glu Glu Leu
 35 40 45

Val Leu Leu Gly His Ser Leu Gly Ile Pro Trp Ala Pro Leu Ser Ser
 50 55 60

Cys Pro Ser Gln Ala Leu Gln Leu Ala Gly Cys Leu Ser Gln Leu His
 65 70 75 80

Ser Gly Leu Phe Leu Tyr Gln Gly Leu Leu Gln Ala Leu Glu Gly Ile
 85 90 95

Ser Pro Glu Leu Gly Pro Thr Leu Asp Thr Leu Gln Leu Asp Val Ala
 100 105 110

Asp Phe Ala Thr Thr Ile Trp Gln Gln Met Glu Glu Leu Gly Met Ala
 115 120 125

Pro Ala Leu Gln Pro Thr Gln Gly Ala Met Pro Ala Phe Ala Ser Ala
 130 135 140

Phe Gln Arg Arg Ala Gly Gly Val Leu Val Ala Ser His Leu Gln Ser
 145 150 155 160

Phe Leu Glu Val Ser Tyr Arg Val Leu Arg His Leu Ala Gln Pro
 165 170 175

(2) INFORMATION FOR SEQ ID NO:84:

(i) SEQUENCE CHARACTERISTICS:

(A) LENGTH: 175 amino acids

(B) TYPE: amino acid

(D) TOPOLOGY: linear

(ii) MOLECULE TYPE: protein

(xi) SEQUENCE DESCRIPTION: SEQ ID NO:84:

Met Thr Pro Leu Gly Pro Ala Ser Ser Leu Pro Gln Ser Phe Leu Leu
 1 5 10 15

Lys Cys Leu Glu Gln Val Arg Lys Ile Gln Gly Asp Gly Ala Ala Leu
 20 25 30

Gln Glu Lys Leu Cys Ala Thr Tyr Lys Leu Cys Lys Pro Glu Glu Leu
 35 40 45

- 106 -

Val Leu Leu Gly His Ser Leu Gly Ile Pro Trp Ala Pro Leu Ser Ser
 50 55 60

Cys Pro Ser Gln Ala Leu Gln Leu Ala Gly Cys Leu Ser Gln Leu His
 65 70 75 80

Ser Gly Leu Phe Leu Tyr Gln Gly Leu Leu Gln Ala Leu Glu Gly Ile
 85 90 95

Ser Pro Glu Leu Gly Pro Thr Leu Asp Thr Leu Gln Leu Asp Val Ala
 100 105 110

Asp Phe Ala Thr Thr Ile Trp Gln Gln Met Glu Glu Leu Gly Met Ala
 115 120 125

Pro Ala Leu Gln Pro Thr Gln Gly Ala Met Pro Ala Phe Ala Ser Ala
 130 135 140

Phe Gln Arg Arg Ala Gly Gly Val Leu Val Ala Ser His Leu Gln Ser
 145 150 155 160

Phe Leu Glu Val Ser Tyr Arg Val Leu Arg His Leu Ala Gln Pro
 165 170 175

(2) INFORMATION FOR SEQ ID NO:85:

(i) SEQUENCE CHARACTERISTICS:

- (A) LENGTH: 175 amino acids
- (B) TYPE: amino acid
- (D) TOPOLOGY: linear

(ii) MOLECULE TYPE: protein

(xi) SEQUENCE DESCRIPTION: SEQ ID NO:85:

Met Thr Pro Leu Gly Pro Ala Ser Ser Leu Pro Gln Ser Phe Leu Leu
 1 5 10 15

Lys Cys Leu Glu Gln Val Arg Lys Ile Gln Gly Asp Gly Ala Ala Leu
 20 25 30

Gln Glu Lys Leu Cys Ala Thr Tyr Lys Leu Cys His Pro Glu Ala Leu
 35 40 45

Val Leu Leu Gly His Ser Leu Gly Ile Pro Trp Ala Pro Leu Ser Ser
 50 55 60

Cys Pro Ser Gln Ala Leu Gln Leu Ala Gly Cys Leu Ser Gln Leu His
 65 70 75 80

Ser Gly Leu Phe Leu Tyr Gln Gly Leu Leu Gln Ala Leu Glu Gly Ile
 85 90 95

Ser Pro Glu Leu Gly Pro Thr Leu Asp Thr Leu Gln Leu Asp Val Ala
 100 105 110

- 107 -

Asp Phe Ala Thr Thr Ile Trp Gln Gln Met Glu Glu Leu Gly Met Ala
 115 120 125

Pro Ala Leu Gln Pro Thr Gln Gly Ala Met Pro Ala Phe Ala Ser Ala
 130 135 140

Phe Gln Arg Arg Ala Gly Gly Val Leu Val Ala Ser His Leu Gln Ser
 145 150 155 160

Phe Leu Glu Val Ser Tyr Arg Val Leu Arg His Leu Ala Gln Pro
 165 170 175

(2) INFORMATION FOR SEQ ID NO:86:

(i) SEQUENCE CHARACTERISTICS:

- (A) LENGTH: 175 amino acids
- (B) TYPE: amino acid
- (D) TOPOLOGY: linear

(ii) MOLECULE TYPE: protein

(xi) SEQUENCE DESCRIPTION: SEQ ID NO:86:

Met Thr Pro Leu Gly Pro Ala Ser Ser Leu Pro Gln Ser Phe Leu Leu
 1 5 10 15

Lys Cys Leu Glu Gln Val Ala Lys Ile Gln Gly Asp Gly Ala Ala Leu
 20 25 30

Gln Glu Lys Leu Cys Ala Thr Tyr Lys Leu Cys His Pro Glu Glu Leu
 35 40 45

Val Leu Leu Gly His Ser Leu Gly Ile Pro Trp Ala Pro Leu Ser Ser
 50 55 60

Cys Pro Ser Gln Ala Leu Gln Leu Ala Gly Cys Leu Ser Gln Leu His
 65 70 75 80

Ser Gly Leu Phe Leu Tyr Gln Gly Leu Leu Gln Ala Leu Glu Gly Ile
 85 90 95

Ser Pro Glu Leu Gly Pro Thr Leu Asp Thr Leu Gln Leu Asp Val Ala
 100 105 110

Asp Phe Ala Thr Thr Ile Trp Gln Gln Met Glu Glu Leu Gly Met Ala
 115 120 125

Pro Ala Leu Gln Pro Thr Gln Gly Ala Met Pro Ala Phe Ala Ser Ala
 130 135 140

Phe Gln Arg Arg Ala Gly Gly Val Leu Val Ala Ser His Leu Gln Ser
 145 150 155 160

Phe Leu Glu Val Ser Tyr Arg Val Leu Arg His Leu Ala Gln Pro
 165 170 175

- 108 -

(2) INFORMATION FOR SEQ ID NO:87:

(i) SEQUENCE CHARACTERISTICS:

- (A) LENGTH: 175 amino acids
- (B) TYPE: amino acid
- (D) TOPOLOGY: linear

(ii) MOLECULE TYPE: protein

(xi) SEQUENCE DESCRIPTION: SEQ ID NO:87:

```

Met Thr Pro Leu Gly Pro Ala Ser Ser Leu Pro Gln Ser Phe Leu Leu
 1           5           10           15
Lys Cys Leu Glu Gln Val Arg Ala Ile Gln Gly Asp Gly Ala Ala Leu
          20           25           30
Gln Glu Lys Leu Cys Ala Thr Tyr Lys Leu Cys His Pro Glu Glu Leu
          35           40           45
Val Leu Leu Gly His Ser Leu Gly Ile Pro Trp Ala Pro Leu Ser Ser
          50           55           60
Cys Pro Ser Gln Ala Leu Gln Leu Ala Gly Cys Leu Ser Gln Leu His
          65           70           75           80
Ser Gly Leu Phe Leu Tyr Gln Gly Leu Leu Gln Ala Leu Glu Gly Ile
          85           90           95
Ser Pro Glu Leu Gly Pro Thr Leu Asp Thr Leu Gln Leu Asp Val Ala
          100          105          110
Asp Phe Ala Thr Thr Ile Trp Gln Gln Met Glu Glu Leu Gly Met Ala
          115          120          125
Pro Ala Leu Gln Pro Thr Gln Gly Ala Met Pro Ala Phe Ala Ser Ala
          130          135          140
Phe Gln Arg Arg Ala Gly Gly Val Leu Val Ala Ser His Leu Gln Ser
          145          150          155          160
Phe Leu Glu Val Ser Tyr Arg Val Leu Arg His Leu Ala Gln Pro
          165          170          175

```

(2) INFORMATION FOR SEQ ID NO:88:

(i) SEQUENCE CHARACTERISTICS:

- (A) LENGTH: 175 amino acids
- (B) TYPE: amino acid
- (D) TOPOLOGY: linear

(ii) MOLECULE TYPE: protein

- 109 -

(xi) SEQUENCE DESCRIPTION: SEQ ID NO:88:

Met Thr Pro Leu Gly Pro Ala Ser Ser Leu Pro Gln Ser Phe Leu Leu
 1 5 10 15

Lys Cys Leu Ala Gln Val Arg Lys Ile Gln Gly Asp Gly Ala Ala Leu
 20 25 30

Gln Glu Lys Leu Cys Ala Thr Tyr Lys Leu Cys His Pro Glu Glu Leu
 35 40 45

Val Leu Leu Gly His Ser Leu Gly Ile Pro Trp Ala Pro Leu Ser Ser
 50 55 60

Cys Pro Ser Gln Ala Leu Gln Leu Ala Gly Cys Leu Ser Gln Leu His
 65 70 75 80

Ser Gly Leu Phe Leu Tyr Gln Gly Leu Leu Gln Ala Leu Glu Gly Ile
 85 90 95

Ser Pro Glu Leu Gly Pro Thr Leu Asp Thr Leu Gln Leu Asp Val Ala
 100 105 110

Asp Phe Ala Thr Thr Ile Trp Gln Gln Met Glu Glu Leu Gly Met Ala
 115 120 125

Pro Ala Leu Gln Pro Thr Gln Gly Ala Met Pro Ala Phe Ala Ser Ala
 130 135 140

Phe Gln Arg Arg Ala Gly Gly Val Leu Val Ala Ser His Leu Gln Ser
 145 150 155 160

Phe Leu Glu Val Ser Tyr Arg Val Leu Arg His Leu Ala Gln Pro
 165 170 175

(2) INFORMATION FOR SEQ ID NO:89:

(i) SEQUENCE CHARACTERISTICS:

- (A) LENGTH: 175 amino acids
- (B) TYPE: amino acid
- (D) TOPOLOGY: linear

(ii) MOLECULE TYPE: protein

(xi) SEQUENCE DESCRIPTION: SEQ ID NO:89:

Met Thr Pro Leu Gly Pro Ala Ser Ser Leu Pro Gln Ser Phe Leu Leu
 1 5 10 15

Lys Cys Leu Glu Gln Val Arg Lys Ile Gln Gly Ala Gly Ala Ala Leu
 20 25 30

Gln Glu Lys Leu Cys Ala Thr Tyr Lys Leu Cys His Pro Glu Glu Leu
 35 40 45

Val Leu Leu Gly His Ser Leu Gly Ile Pro Trp Ala Pro Leu Ser Ser
 50 55 60

- 110 -

Cys Pro Ser Gln Ala Leu Gln Leu Ala Gly Cys Leu Ser Gln Leu His
 65 70 75 80

Ser Gly Leu Phe Leu Tyr Gln Gly Leu Leu Gln Ala Leu Glu Gly Ile
 85 90 95

Ser Pro Glu Leu Gly Pro Thr Leu Asp Thr Leu Gln Leu Asp Val Ala
 100 105 110

Asp Phe Ala Thr Thr Ile Trp Gln Gln Met Glu Glu Leu Gly Met Ala
 115 120 125

Pro Ala Leu Gln Pro Thr Gln Gly Ala Met Pro Ala Phe Ala Ser Ala
 130 135 140

Phe Gln Arg Arg Ala Gly Gly Val Leu Val Ala Ser His Leu Gln Ser
 145 150 155 160

Phe Leu Glu Val Ser Tyr Arg Val Leu Arg His Leu Ala Gln Pro
 165 170 175

(2) INFORMATION FOR SEQ ID NO:90:

(i) SEQUENCE CHARACTERISTICS:

- (A) LENGTH: 175 amino acids
- (B) TYPE: amino acid
- (D) TOPOLOGY: linear

(ii) MOLECULE TYPE: protein

(xi) SEQUENCE DESCRIPTION: SEQ ID NO:90:

Met Thr Pro Leu Gly Pro Ala Ser Ser Leu Pro Gln Ser Phe Leu Leu
 1 5 10 15

Lys Cys Leu Glu Gln Val Arg Lys Ile Gln Gly Asp Gly Ala Ala Leu
 20 25 30

Gln Glu Lys Leu Cys Ala Thr Tyr Lys Leu Cys His Pro Glu Glu Leu
 35 40 45

Val Leu Leu Gly His Ser Leu Gly Ile Pro Trp Ala Pro Leu Ser Ser
 50 55 60

Cys Pro Ser Gln Ala Leu Gln Leu Ala Gly Cys Leu Ser Gln Leu His
 65 70 75 80

Ser Gly Leu Phe Leu Tyr Gln Gly Leu Leu Gln Ala Leu Glu Gly Ile
 85 90 95

Ser Pro Glu Leu Gly Pro Thr Leu Asp Thr Leu Gln Leu Asp Val Ala
 100 105 110

Asp Phe Ala Thr Thr Ile Trp Gln Gln Met Glu Glu Leu Gly Glu Ala
 115 120 125

Pro Ala Leu Gln Pro Thr Gln Gly Ala Met Pro Ala Phe Ala Ser Ala
 130 135 140

- 111 -

Phe Gln Arg Arg Ala Gly Gly Val Leu Val Ala Ser His Leu Gln Ser
 145 150 155 160

Phe Leu Glu Val Ser Tyr Arg Val Leu Arg His Leu Ala Gln Pro
 165 170 175

(2) INFORMATION FOR SEQ ID NO:91:

(i) SEQUENCE CHARACTERISTICS:

(A) LENGTH: 175 amino acids

(B) TYPE: amino acid

(D) TOPOLOGY: linear

(ii) MOLECULE TYPE: protein

(xi) SEQUENCE DESCRIPTION: SEQ ID NO:91:

Met Thr Pro Leu Gly Pro Ala Ser Ser Leu Pro Gln Ser Phe Leu Leu
 1 5 10 15

Lys Cys Leu Glu Gln Val Arg Lys Ile Gln Gly Asp Gly Ala Ala Leu
 20 25 30

Gln Glu Lys Leu Cys Ala Thr Tyr Lys Leu Cys His Pro Glu Glu Leu
 35 40 45

Val Leu Leu Gly His Ser Leu Gly Ile Pro Trp Ala Pro Leu Ser Ser
 50 55 60

Cys Pro Ser Gln Ala Leu Gln Leu Ala Gly Cys Leu Ser Gln Leu His
 65 70 75 80

Ser Gly Leu Phe Leu Tyr Gln Gly Leu Leu Gln Ala Leu Glu Gly Ile
 85 90 95

Ser Pro Glu Leu Gly Pro Thr Leu Asp Thr Leu Gln Leu Asp Val Ala
 100 105 110

Asp Phe Ala Thr Thr Ile Trp Gln Gln Met Glu Glu Leu Gly Met Ala
 115 120 125

Pro Ala Leu Gln Pro Thr Gln Gly Ala Glu Pro Ala Phe Ala Ser Ala
 130 135 140

Phe Gln Arg Arg Ala Gly Gly Val Leu Val Ala Ser His Leu Gln Ser
 145 150 155 160

Phe Leu Glu Val Ser Tyr Arg Val Leu Arg His Leu Ala Gln Pro
 165 170 175

(2) INFORMATION FOR SEQ ID NO:92:

(i) SEQUENCE CHARACTERISTICS:

(A) LENGTH: 175 amino acids

(B) TYPE: amino acid

(D) TOPOLOGY: linear

(ii) MOLECULE TYPE: protein

(xi) SEQUENCE DESCRIPTION: SEQ ID NO:92:

Met Thr Pro Leu Gly Pro Ala Ser Ser Leu Pro Gln Ser Phe Leu Leu
 1 5 10 15
 Lys Cys Leu Glu Gln Val Arg Lys Ile Gln Gly Asp Gly Ala Ala Leu
 20 25 30
 Gln Glu Lys Leu Cys Ala Thr Tyr Lys Leu Cys His Pro Glu Glu Leu
 35 40 45
 Val Leu Leu Gly His Ser Leu Gly Ile Pro Trp Ala Pro Leu Ser Ser
 50 55 60
 Cys Pro Ser Gln Ala Leu Gln Leu Ala Gly Cys Leu Ser Gln Leu His
 65 70 75 80
 Ser Gly Leu Phe Leu Tyr Gln Gly Leu Leu Gln Ala Leu Glu Gly Ile
 85 90 95
 Ser Pro Glu Leu Gly Pro Thr Leu Asp Thr Leu Gln Leu Asp Val Ala
 100 105 110
 Asp Phe Ala Thr Thr Ile Trp Gln Gln Met Glu Glu Leu Gly Leu Ala
 115 120 125
 Pro Ala Leu Gln Pro Thr Gln Gly Ala Met Pro Ala Phe Ala Ser Ala
 130 135 140
 Phe Gln Arg Arg Ala Gly Gly Val Leu Val Ala Ser His Leu Gln Ser
 145 150 155 160
 Phe Leu Glu Val Ser Tyr Arg Val Leu Arg His Leu Ala Gln Pro
 165 170 175

(2) INFORMATION FOR SEQ ID NO:93:

(i) SEQUENCE CHARACTERISTICS:

(A) LENGTH: 175 amino acids

(B) TYPE: amino acid

(D) TOPOLOGY: linear

(ii) MOLECULE TYPE: protein

(xi) SEQUENCE DESCRIPTION: SEQ ID NO:93:

Met Thr Pro Leu Gly Pro Ala Ser Ser Leu Pro Gln Ser Phe Leu Leu
 1 5 10 15
 Lys Cys Leu Glu Gln Val Arg Lys Ile Gln Gly Asp Gly Ala Ala Leu
 20 25 30

- 114 -

Ser Pro Glu Leu Gly Pro Thr Leu Asp Thr Leu Gln Leu Asp Val Ala
 100 105 110

Asp Phe Ala Thr Thr Ile Trp Gln Gln Met Glu Glu Leu Gly Met Ala
 115 120 125

Pro Ala Leu Gln Pro Thr Gln Gly Ala Met Pro Ala Phe Ala Ser Ala
 130 135 140

Phe Gln Arg Arg Ala Gly Gly Val Leu Val Ala Ser His Leu Gln Ser
 145 150 155 160

Phe Leu Glu Val Ser Tyr Arg Val Leu Arg His Leu Ala Gln Pro
 165 170 175

(2) INFORMATION FOR SEQ ID NO:95:

(i) SEQUENCE CHARACTERISTICS:

- (A) LENGTH: 175 amino acids
- (B) TYPE: amino acid
- (D) TOPOLOGY: linear

(ii) MOLECULE TYPE: protein

(xi) SEQUENCE DESCRIPTION: SEQ ID NO:95:

Met Thr Pro Leu Gly Pro Ala Ser Ser Leu Pro Glu Ser Phe Leu Leu
 1 5 10 15

Lys Cys Leu Glu Glu Val Arg Lys Ile Gln Gly Asp Gly Ala Ala Leu
 20 25 30

Gln Glu Lys Leu Cys Ala Thr Tyr Lys Leu Cys His Pro Glu Glu Leu
 35 40 45

Val Leu Leu Gly His Ser Leu Gly Ile Pro Trp Ala Pro Leu Ser Ser
 50 55 60

Cys Pro Ser Gln Ala Leu Gln Leu Ala Gly Cys Leu Ser Gln Leu His
 65 70 75 80

Ser Gly Leu Phe Leu Tyr Gln Gly Leu Leu Gln Ala Leu Glu Gly Ile
 85 90 95

Ser Pro Glu Leu Gly Pro Thr Leu Asp Thr Leu Gln Leu Asp Val Ala
 100 105 110

Asp Phe Ala Thr Thr Ile Trp Gln Gln Met Glu Glu Leu Gly Met Ala
 115 120 125

Pro Ala Leu Gln Pro Thr Gln Gly Ala Met Pro Ala Phe Ala Ser Ala
 130 135 140

Phe Gln Arg Arg Ala Gly Gly Val Leu Val Ala Ser His Leu Gln Ser
 145 150 155 160

Phe Leu Glu Val Ser Tyr Arg Val Leu Arg His Leu Ala Gln Pro
 165 170 175

- 115 -

(2) INFORMATION FOR SEQ ID NO:96:

(i) SEQUENCE CHARACTERISTICS:

(A) LENGTH: 175 amino acids

(B) TYPE: amino acid

(D) TOPOLOGY: linear

(ii) MOLECULE TYPE: protein

(xi) SEQUENCE DESCRIPTION: SEQ ID NO:96:

```

Met Thr Pro Leu Gly Pro Ala Ser Ser Leu Pro Glu Ser Phe Leu Leu
 1                5                10                15

Lys Cys Leu Glu Glu Val Arg Lys Ile Gln Gly Asp Gly Ala Ala Leu
                20                25                30

Gln Glu Lys Leu Cys Ala Thr Tyr Lys Leu Cys His Pro Glu Glu Leu
                35                40                45

Val Leu Leu Gly His Ser Leu Gly Ile Pro Trp Ala Pro Leu Ser Ser
 50                55                60

Cys Pro Ser Glu Ala Leu Gln Leu Ala Gly Cys Leu Ser Gln Leu His
 65                70                75                80

Ser Gly Leu Phe Leu Tyr Gln Gly Leu Leu Gln Ala Leu Glu Gly Ile
                85                90                95

Ser Pro Glu Leu Gly Pro Thr Leu Asp Thr Leu Gln Leu Asp Val Ala
                100                105                110

Asp Phe Ala Thr Thr Ile Trp Gln Gln Met Glu Glu Leu Gly Met Ala
                115                120                125

Pro Ala Leu Gln Pro Thr Gln Gly Ala Met Pro Ala Phe Ala Ser Ala
 130                135                140

Phe Gln Arg Arg Ala Gly Gly Val Leu Val Ala Ser His Leu Gln Ser
 145                150                155                160

Phe Leu Glu Val Ser Tyr Arg Val Leu Arg His Leu Ala Gln Pro
                165                170                175

```

(2) INFORMATION FOR SEQ ID NO:97:

(i) SEQUENCE CHARACTERISTICS:

(A) LENGTH: 175 amino acids

(B) TYPE: amino acid

(D) TOPOLOGY: linear

(ii) MOLECULE TYPE: protein

- 116 -

(xi) SEQUENCE DESCRIPTION: SEQ ID NO:97:

Met Thr Pro Leu Gly Pro Ala Ser Ser Leu Pro Gln Gly Phe Leu Leu
 1 5 10 15

Lys Cys Leu Ala Gln Val Arg Lys Ile Gln Gly Asp Gly Ala Ala Leu
 20 25 30

Gln Glu Lys Leu Cys Ala Thr Tyr Lys Leu Cys His Pro Glu Glu Leu
 35 40 45

Val Leu Leu Gly His Ser Leu Gly Ile Pro Trp Ala Pro Leu Ser Ser
 50 55 60

Cys Pro Ser Gln Ala Leu Gln Leu Ala Gly Cys Leu Ser Gln Leu His
 65 70 75 80

Ser Gly Leu Phe Leu Tyr Gln Gly Leu Leu Gln Ala Leu Glu Gly Ile
 85 90 95

Ser Pro Glu Leu Gly Pro Thr Leu Asp Thr Leu Gln Leu Asp Val Ala
 100 105 110

Asp Phe Ala Thr Thr Ile Trp Gln Gln Met Glu Glu Leu Gly Met Ala
 115 120 125

Pro Ala Leu Gln Pro Thr Gln Gly Ala Met Pro Ala Phe Ala Ser Ala
 130 135 140

Phe Gln Arg Arg Ala Gly Gly Val Leu Val Ala Ser His Leu Gln Ser
 145 150 155 160

Phe Leu Glu Val Ser Tyr Arg Val Leu Arg His Leu Ala Gln Pro
 165 170 175

(2) INFORMATION FOR SEQ ID NO:98:

(i) SEQUENCE CHARACTERISTICS:

- (A) LENGTH: 175 amino acids
- (B) TYPE: amino acid
- (D) TOPOLOGY: linear

(ii) MOLECULE TYPE: protein

(xi) SEQUENCE DESCRIPTION: SEQ ID NO:98:

Met Thr Pro Leu Gly Pro Ala Ser Ser Leu Pro Gln Ser Phe Leu Leu
 1 5 10 15

Lys Cys Leu Glu Gln Val Arg Lys Ile Gln Gly Asp Gly Ala Ala Leu
 20 25 30

Gln Glu Lys Leu Cys Ala Thr Tyr Lys Leu Cys His Pro Glu Glu Leu
 35 40 45

- 117 -

Val Leu Leu Gly His Ser Leu Gly Ile Pro Trp Ala Pro Leu Ser Ser
 50 55 60
 Cys Pro Ser Gln Ala Leu Gln Leu Ala Gly Cys Leu Ser Gln Leu His
 65 70 75 80
 Ser Gly Leu Phe Leu Tyr Gln Gly Leu Leu Gln Ala Leu Glu Gly Ile
 85 90 95
 Ser Pro Glu Leu Gly Pro Thr Leu Asp Thr Leu Gln Leu Asp Val Ala
 100 105 110
 Asp Phe Ala Thr Thr Ile Trp Gln Gln Met Glu Glu Leu Gly Leu Ala
 115 120 125
 Pro Ala Leu Gln Pro Thr Gln Gly Ala Leu Pro Ala Phe Ala Ser Ala
 130 135 140
 Phe Gln Arg Arg Ala Gly Gly Val Leu Val Ala Ser His Leu Gln Ser
 145 150 155 160
 Phe Leu Glu Val Ser Tyr Arg Val Leu Arg His Leu Ala Gln Pro
 165 170 175

(2) INFORMATION FOR SEQ ID NO:99:

(i) SEQUENCE CHARACTERISTICS:

(A) LENGTH: 175 amino acids

(B) TYPE: amino acid

(D) TOPOLOGY: linear

(ii) MOLECULE TYPE: protein

(xi) SEQUENCE DESCRIPTION: SEQ ID NO:99:

Met Thr Pro Leu Gly Pro Ala Ser Ser Leu Pro Gln Ala Phe Leu Leu
 1 5 10 15
 Lys Cys Leu Glu Gln Val Arg Lys Ile Gln Gly Asp Gly Ala Ala Leu
 20 25 30
 Gln Glu Lys Leu Cys Ala Thr Tyr Lys Leu Cys His Pro Glu Glu Leu
 35 40 45
 Val Leu Leu Gly His Ser Leu Gly Ile Pro Trp Ala Pro Leu Ser Ser
 50 55 60
 Cys Pro Ser Gln Ala Leu Gln Leu Ala Gly Cys Leu Ser Gln Leu His
 65 70 75 80
 Ser Gly Leu Phe Leu Tyr Gln Gly Leu Leu Gln Ala Leu Glu Gly Ile
 85 90 95
 Ser Pro Glu Leu Gly Pro Thr Leu Asp Thr Leu Gln Leu Asp Val Ala
 100 105 110

- 118 -

Asp Phe Ala Thr Thr Ile Trp Gln Gln Met Glu Glu Leu Gly Met Ala
 115 120 125

Pro Ala Leu Gln Pro Thr Gln Gly Ala Met Pro Ala Phe Ala Ser Ala
 130 135 140

Phe Gln Arg Arg Ala Gly Gly Val Leu Val Ala Ser His Leu Gln Ser
 145 150 155 160

Phe Leu Glu Val Ser Tyr Arg Val Leu Arg His Leu Ala Gln Pro
 165 170 175

(2) INFORMATION FOR SEQ ID NO:100:

(i) SEQUENCE CHARACTERISTICS:

- (A) LENGTH: 175 amino acids
- (B) TYPE: amino acid
- (D) TOPOLOGY: linear

(ii) MOLECULE TYPE: protein

(xi) SEQUENCE DESCRIPTION: SEQ ID NO:100:

Met Thr Pro Leu Gly Pro Ala Ser Ser Leu Pro Gln Ser Phe Leu Leu
 1 5 10 15

Ala Cys Leu Glu Gln Val Arg Lys Ile Gln Gly Asp Gly Ala Ala Leu
 20 25 30

Gln Glu Lys Leu Cys Ala Thr Tyr Lys Leu Cys His Pro Glu Glu Leu
 35 40 45

Val Leu Leu Gly His Ser Leu Gly Ile Pro Trp Ala Pro Leu Ser Ser
 50 55 60

Cys Pro Ser Gln Ala Leu Gln Leu Ala Gly Cys Leu Ser Gln Leu His
 65 70 75 80

Ser Gly Leu Phe Leu Tyr Gln Gly Leu Leu Gln Ala Leu Glu Gly Ile
 85 90 95

Ser Pro Glu Leu Gly Pro Thr Leu Asp Thr Leu Gln Leu Asp Val Ala
 100 105 110

Asp Phe Ala Thr Thr Ile Trp Gln Gln Met Glu Glu Leu Gly Met Ala
 115 120 125

Pro Ala Leu Gln Pro Thr Gln Gly Ala Met Pro Ala Phe Ala Ser Ala
 130 135 140

Phe Gln Arg Arg Ala Gly Gly Val Leu Val Ala Ser His Leu Gln Ser
 145 150 155 160

Phe Leu Glu Val Ser Tyr Arg Val Leu Arg His Leu Ala Gln Pro
 165 170 175

- 119 -

(2) INFORMATION FOR SEQ ID NO:101:

(i) SEQUENCE CHARACTERISTICS:

- (A) LENGTH: 175 amino acids
- (B) TYPE: amino acid
- (D) TOPOLOGY: linear

(ii) MOLECULE TYPE: protein

(xi) SEQUENCE DESCRIPTION: SEQ ID NO:101:

```

Met Thr Pro Leu Gly Pro Ala Ser Ser Leu Pro Gln Ser Phe Leu Leu
 1           5           10           15
Lys Cys Leu Glu Gln Val Arg Lys Ile Gln Gly Asp Gly Ala Ala Leu
           20           25           30
Gln Glu Lys Leu Cys Ala Thr Tyr Lys Leu Cys His Pro Glu Glu Leu
           35           40           45
Val Leu Leu Gly His Ser Leu Gly Ile Pro Trp Ala Pro Leu Ser Ser
           50           55           60
Cys Pro Ser Gln Ala Leu Gln Leu Ala Gly Cys Leu Ser Gln Leu His
           65           70           75           80
Ser Gly Leu Phe Leu Tyr Gln Gly Leu Leu Gln Ala Leu Glu Gly Ile
           85           90           95
Ser Pro Glu Leu Gly Pro Thr Leu Asp Thr Leu Gln Leu Asp Val Ala
           100          105          110
Asp Phe Ala Thr Thr Ile Trp Gln Ala Met Glu Glu Leu Gly Met Ala
           115          120          125
Pro Ala Leu Gln Pro Thr Gln Gly Ala Met Pro Ala Phe Ala Ser Ala
           130          135          140
Phe Gln Arg Arg Ala Gly Gly Val Leu Val Ala Ser His Leu Gln Ser
           145          150          155          160
Phe Leu Glu Val Ser Tyr Arg Val Leu Arg His Leu Ala Gln Pro
           165          170          175

```

(2) INFORMATION FOR SEQ ID NO:102:

(i) SEQUENCE CHARACTERISTICS:

- (A) LENGTH: 175 amino acids
- (B) TYPE: amino acid
- (D) TOPOLOGY: linear

(ii) MOLECULE TYPE: protein

(xi) SEQUENCE DESCRIPTION: SEQ ID NO:102:

```

Met Thr Pro Leu Gly Pro Ala Ser Ser Leu Pro Gln Ser Phe Leu Leu
 1           5           10           15

```

- 120 -

Lys Cys Leu Glu Ala Val Arg Lys Ile Gln Gly Asp Gly Ala Ala Leu
 20 25 30
 Gln Glu Lys Leu Cys Ala Thr Tyr Lys Leu Cys His Pro Glu Glu Leu
 35 40 45
 Val Leu Leu Gly His Ser Leu Gly Ile Pro Trp Ala Pro Leu Ser Ser
 50 55 60
 Cys Pro Ser Gln Ala Leu Gln Leu Ala Gly Cys Leu Ser Gln Leu His
 65 70 75 80
 Ser Gly Leu Phe Leu Tyr Gln Gly Leu Leu Gln Ala Leu Glu Gly Ile
 85 90 95
 Ser Pro Glu Leu Gly Pro Thr Leu Asp Thr Leu Gln Leu Asp Val Ala
 100 105 110
 Asp Phe Ala Thr Thr Ile Trp Gln Gln Met Glu Glu Leu Gly Met Ala
 115 120 125
 Pro Ala Leu Gln Pro Thr Gln Gly Ala Met Pro Ala Phe Ala Ser Ala
 130 135 140
 Phe Gln Arg Arg Ala Gly Gly Val Leu Val Ala Ser His Leu Gln Ser
 145 150 155 160
 Phe Leu Glu Val Ser Tyr Arg Val Leu Arg His Leu Ala Gln Pro
 165 170 175

(2) INFORMATION FOR SEQ ID NO:103:

(i) SEQUENCE CHARACTERISTICS:

- (A) LENGTH: 175 amino acids
- (B) TYPE: amino acid
- (D) TOPOLOGY: linear

(ii) MOLECULE TYPE: protein

(xi) SEQUENCE DESCRIPTION: SEQ ID NO:103:

Met Thr Pro Leu Gly Pro Ala Ser Ser Leu Pro Gln Ser Phe Leu Leu
 1 5 10 15
 Lys Cys Leu Glu Gln Val Arg Lys Ile Gln Gly Asp Gly Ala Ala Leu
 20 25 30
 Gln Glu Lys Leu Cys Ala Thr Tyr Lys Leu Cys Ala Pro Glu Glu Leu
 35 40 45
 Val Leu Leu Gly His Ser Leu Gly Ile Pro Trp Ala Pro Leu Ser Ser
 50 55 60
 Cys Pro Ser Gln Ala Leu Gln Leu Ala Gly Cys Leu Ser Gln Leu His
 65 70 75 80

- 121 -

Ser Gly Leu Phe Leu Tyr Gln Gly Leu Leu Gln Ala Leu Glu Gly Ile
85 90 95

Ser Pro Glu Leu Gly Pro Thr Leu Asp Thr Leu Gln Leu Asp Val Ala
100 105 110

Asp Phe Ala Thr Thr Ile Trp Gln Gln Met Glu Glu Leu Gly Met Ala
115 120 125

Pro Ala Leu Gln Pro Thr Gln Gly Ala Met Pro Ala Phe Ala Ser Ala
130 135 140

Phe Gln Arg Arg Ala Gly Gly Val Leu Val Ala Ser His Leu Gln Ser
145 150 155 160

Phe Leu Glu Val Ser Tyr Arg Val Leu Arg His Leu Ala Gln Pro
165 170 175

(2) INFORMATION FOR SEQ ID NO:104:

(i) SEQUENCE CHARACTERISTICS:

- (A) LENGTH: 175 amino acids
- (B) TYPE: amino acid
- (D) TOPOLOGY: linear

(ii) MOLECULE TYPE: protein

(xi) SEQUENCE DESCRIPTION: SEQ ID NO:104:

Met Thr Pro Leu Gly Pro Ala Ser Ser Leu Pro Gln Ser Phe Leu Leu
1 5 10 15

Lys Cys Leu Glu Gln Val Arg Lys Ile Gln Gly Asp Gly Ala Ala Leu
20 25 30

Gln Glu Lys Leu Cys Ala Thr Tyr Lys Leu Cys His Pro Glu Glu Leu
35 40 45

Val Leu Leu Gly Ala Ser Leu Gly Ile Pro Trp Ala Pro Leu Ser Ser
50 55 60

Cys Pro Ser Gln Ala Leu Gln Leu Ala Gly Cys Leu Ser Gln Leu His
65 70 75 80

Ser Gly Leu Phe Leu Tyr Gln Gly Leu Leu Gln Ala Leu Glu Gly Ile
85 90 95

Ser Pro Glu Leu Gly Pro Thr Leu Asp Thr Leu Gln Leu Asp Val Ala
100 105 110

Asp Phe Ala Thr Thr Ile Trp Gln Gln Met Glu Glu Leu Gly Met Ala
115 120 125

Pro Ala Leu Gln Pro Thr Gln Gly Ala Met Pro Ala Phe Ala Ser Ala
130 135 140

- 122 -

Phe Gln Arg Arg Ala Gly Gly Val Leu Val Ala Ser His Leu Gln Ser
 145 150 155 160

Phe Leu Glu Val Ser Tyr Arg Val Leu Arg His Leu Ala Gln Pro
 165 170 175

(2) INFORMATION FOR SEQ ID NO:105:

(i) SEQUENCE CHARACTERISTICS:

- (A) LENGTH: 175 amino acids
- (B) TYPE: amino acid
- (D) TOPOLOGY: linear

(ii) MOLECULE TYPE: protein

(xi) SEQUENCE DESCRIPTION: SEQ ID NO:105:

Met Thr Pro Leu Gly Pro Ala Ser Ser Leu Pro Gln Ser Phe Leu Leu
 1 5 10 15

Lys Cys Leu Glu Gln Val Arg Lys Ile Gln Gly Asp Gly Ala Ala Leu
 20 25 30

Gln Glu Lys Leu Cys Ala Thr Tyr Lys Leu Cys His Pro Glu Glu Leu
 35 40 45

Val Leu Leu Gly His Ser Leu Gly Ile Pro Trp Ala Pro Leu Ser Ser
 50 55 60

Cys Pro Ser Gln Ala Leu Gln Leu Ala Gly Cys Leu Ser Gln Leu His
 65 70 75 80

Ser Gly Leu Phe Leu Tyr Gln Gly Leu Leu Gln Ala Leu Glu Gly Ile
 85 90 95

Ser Pro Glu Leu Gly Pro Thr Leu Asp Thr Leu Gln Leu Ala Val Ala
 100 105 110

Asp Phe Ala Thr Thr Ile Trp Gln Gln Met Glu Glu Leu Gly Met Ala
 115 120 125

Pro Ala Leu Gln Pro Thr Gln Gly Ala Met Pro Ala Phe Ala Ser Ala
 130 135 140

Phe Gln Arg Arg Ala Gly Gly Val Leu Val Ala Ser His Leu Gln Ser
 145 150 155 160

Phe Leu Glu Val Ser Tyr Arg Val Leu Arg His Leu Ala Gln Pro
 165 170 175

(2) INFORMATION FOR SEQ ID NO:106:

(i) SEQUENCE CHARACTERISTICS:

- (A) LENGTH: 175 amino acids
- (B) TYPE: amino acid
- (D) TOPOLOGY: linear

- 123 -

(ii) MOLECULE TYPE: protein

(xi) SEQUENCE DESCRIPTION: SEQ ID NO:106:

Met Thr Pro Leu Gly Pro Ala Ser Ser Leu Pro Gln Ser Phe Leu Leu
 1 5 10 15

Lys Cys Leu Glu Gln Val Arg Lys Ile Gln Gly Asp Gly Ala Ala Leu
 20 25 30

Gln Glu Lys Leu Cys Ala Thr Tyr Lys Leu Cys His Pro Glu Glu Leu
 35 40 45

Val Leu Leu Gly His Ser Leu Gly Ile Pro Trp Ala Pro Leu Ser Ser
 50 55 60

Cys Pro Ser Gln Ala Leu Gln Leu Ala Gly Cys Leu Ser Gln Leu His
 65 70 75 80

Ser Gly Leu Phe Leu Tyr Gln Gly Leu Leu Gln Ala Leu Glu Gly Ile
 85 90 95

Ser Pro Glu Leu Gly Pro Thr Leu Asp Thr Leu Gln Leu Asp Val Ala
 100 105 110

Ala Phe Ala Thr Thr Ile Trp Gln Gln Met Glu Glu Leu Gly Met Ala
 115 120 125

Pro Ala Leu Gln Pro Thr Gln Gly Ala Met Pro Ala Phe Ala Ser Ala
 130 135 140

Phe Gln Arg Arg Ala Gly Gly Val Leu Val Ala Ser His Leu Gln Ser
 145 150 155 160

Phe Leu Glu Val Ser Tyr Arg Val Leu Arg His Leu Ala Gln Pro
 165 170 175

(2) INFORMATION FOR SEQ ID NO:107:

(i) SEQUENCE CHARACTERISTICS:

- (A) LENGTH: 175 amino acids
- (B) TYPE: amino acid
- (D) TOPOLOGY: linear

(ii) MOLECULE TYPE: protein

(xi) SEQUENCE DESCRIPTION: SEQ ID NO:107:

Met Thr Pro Leu Gly Pro Ala Ser Ser Leu Pro Gln Ser Phe Leu Leu
 1 5 10 15

Lys Cys Leu Glu Gln Val Arg Lys Ile Gln Gly Asp Gly Ala Ala Leu
 20 25 30

Gln Glu Lys Leu Cys Ala Thr Tyr Lys Leu Cys His Pro Glu Glu Leu
 35 40 45

- 124 -

Val Leu Leu Gly His Ser Leu Gly Ile Pro Trp Ala Pro Leu Ser Ser
 50 55 60

Cys Pro Ser Gln Ala Leu Gln Leu Ala Gly Cys Leu Ser Gln Leu His
 65 70 75 80

Ser Gly Leu Phe Leu Tyr Gln Gly Leu Leu Gln Ala Leu Glu Gly Ile
 85 90 95

Ser Pro Glu Leu Gly Pro Thr Leu Asp Thr Leu Gln Leu Asp Val Ala
 100 105 110

Asp Phe Ala Thr Ala Ile Trp Gln Gln Met Glu Glu Leu Gly Met Ala
 115 120 125

Pro Ala Leu Gln Pro Thr Gln Gly Ala Met Pro Ala Phe Ala Ser Ala
 130 135 140

Phe Gln Arg Arg Ala Gly Gly Val Leu Val Ala Ser His Leu Gln Ser
 145 150 155 160

Phe Leu Glu Val Ser Tyr Arg Val Leu Arg His Leu Ala Gln Pro
 165 170 175

(2) INFORMATION FOR SEQ ID NO:108:

(i) SEQUENCE CHARACTERISTICS:

- (A) LENGTH: 175 amino acids
- (B) TYPE: amino acid
- (D) TOPOLOGY: linear

(ii) MOLECULE TYPE: protein

(xi) SEQUENCE DESCRIPTION: SEQ ID NO:108:

Met Thr Pro Leu Gly Pro Ala Ser Ser Leu Pro Gln Ser Phe Leu Leu
 1 5 10 15

Lys Cys Leu Glu Gln Val Arg Lys Ile Gln Gly Ala Gly Ala Ala Leu
 20 25 30

Gln Glu Lys Leu Cys Ala Thr Tyr Lys Leu Cys His Pro Glu Glu Leu
 35 40 45

Val Leu Leu Gly His Ser Leu Gly Ile Pro Trp Ala Pro Leu Ser Ser
 50 55 60

Cys Pro Ser Gln Ala Leu Gln Leu Ala Gly Cys Leu Ser Gln Leu His
 65 70 75 80

Ser Gly Leu Phe Leu Tyr Gln Gly Leu Leu Gln Ala Leu Glu Gly Ile
 85 90 95

Ser Pro Glu Leu Gly Pro Thr Leu Asp Thr Leu Gln Leu Ala Val Ala
 100 105 110

- 125 -

Asp Phe Ala Thr Thr Ile Trp Gln Gln Met Glu Glu Leu Gly Met Ala
 115 120 125

Pro Ala Leu Gln Pro Thr Gln Gly Ala Met Pro Ala Phe Ala Ser Ala
 130 135 140

Phe Gln Arg Arg Ala Gly Gly Val Leu Val Ala Ser His Leu Gln Ser
 145 150 155 160

Phe Leu Glu Val Ser Tyr Arg Val Leu Arg His Leu Ala Gln Pro
 165 170 175

(2) INFORMATION FOR SEQ ID NO:109:

(i) SEQUENCE CHARACTERISTICS:

- (A) LENGTH: 175 amino acids
- (B) TYPE: amino acid
- (D) TOPOLOGY: linear

(ii) MOLECULE TYPE: protein

(xi) SEQUENCE DESCRIPTION: SEQ ID NO:109:

Met Thr Pro Leu Gly Pro Ala Ser Ser Leu Pro Gln Ser Phe Leu Leu
 1 5 10 15

Lys Cys Leu Glu Gln Val Arg Lys Ile Gln Gly Asp Gly Ala Ala Leu
 20 25 30

Gln Glu Lys Leu Cys Ala Thr Tyr Lys Leu Cys His Pro Glu Glu Leu
 35 40 45

Val Leu Leu Gly His Ser Leu Gly Ile Pro Trp Ala Pro Leu Ser Ser
 50 55 60

Cys Pro Ser Gln Ala Leu Gln Leu Ala Gly Cys Leu Ser Gln Leu His
 65 70 75 80

Ser Gly Leu Phe Leu Tyr Gln Gly Leu Leu Gln Ala Leu Glu Gly Ile
 85 90 95

Ser Pro Glu Leu Gly Pro Thr Leu Asp Thr Leu Gln Leu Asp Val Ala
 100 105 110

Asp Phe Ala Thr Thr Ile Trp Gln Gln Met Glu Ala Leu Gly Met Ala
 115 120 125

Pro Ala Leu Gln Pro Thr Gln Gly Ala Met Pro Ala Phe Ala Ser Ala
 130 135 140

Phe Gln Arg Arg Ala Gly Gly Val Leu Val Ala Ser His Leu Gln Ser
 145 150 155 160

Phe Leu Glu Val Ser Tyr Arg Val Leu Arg His Leu Ala Gln Pro
 165 170 175

- 126 -

(2) INFORMATION FOR SEQ ID NO:110:

(i) SEQUENCE CHARACTERISTICS:

- (A) LENGTH: 175 amino acids
- (B) TYPE: amino acid
- (D) TOPOLOGY: linear

(ii) MOLECULE TYPE: protein

(xi) SEQUENCE DESCRIPTION: SEQ ID NO:110:

```

Met Thr Pro Leu Gly Pro Ala Ser Ser Leu Pro Gln Ser Phe Leu Leu
 1           5           10           15
Lys Cys Leu Glu Gln Val Arg Lys Ile Gln Gly Asp Gly Ala Ala Leu
          20           25           30
Gln Glu Lys Leu Cys Ala Thr Tyr Lys Leu Cys His Pro Glu Glu Leu
          35           40           45
Val Leu Leu Gly His Ser Leu Gly Ile Pro Trp Ala Pro Leu Ser Ser
          50           55           60
Cys Pro Ser Gln Ala Leu Gln Leu Ala Gly Cys Leu Ser Gln Leu His
          65           70           75           80
Ser Gly Leu Phe Leu Tyr Gln Gly Leu Leu Gln Ala Leu Glu Gly Ile
          85           90           95
Ser Pro Glu Leu Gly Pro Thr Leu Asp Thr Leu Gln Leu Asp Val Ala
          100          105          110
Asp Val Ala Thr Ala Ile Trp Gln Gln Met Glu Glu Leu Gly Met Ala
          115          120          125
Pro Ala Leu Gln Pro Thr Gln Gly Ala Met Pro Ala Phe Ala Ser Ala
          130          135          140
Phe Gln Arg Arg Ala Gly Gly Val Leu Val Ala Ser His Leu Gln Ser
          145          150          155          160
Phe Leu Glu Val Ser Tyr Arg Val Leu Arg His Leu Ala Gln Pro
          165          170          175

```

- 127 -

WHAT IS CLAIMED IS:

1. A method for preparing a G-CSF analog comprising the steps of:
 - (a) viewing information conveying the
5 three dimensional structure of a G-CSF molecule;
 - (b) selecting from said viewed information at least one site on said G-CSF molecule for alteration;
 - (c) preparing a G-CSF molecule having
10 such alteration; and
 - (d) optionally, testing such G-CSF molecule for a desired characteristic.
2. A computer based method for preparing a
G-CSF analog comprising the steps of:
 - 15 (a) providing computer expression of the three dimensional structure of a G-CSF molecule;
 - (b) selecting from said computer expression at least one site on said G-CSF molecule for alteration;
 - 20 (c) preparing a G-CSF molecule having such alteration; and,
 - (d) optionally, testing such G-CSF molecule for a desired characteristic.
3. A method for preparing a G-CSF analog with
25 the aid of a computer comprising:
 - (a) providing said computer with the means for displaying the three dimensional structure of a G-CSF molecule including displaying the composition of moieties of said G-CSF molecule, preferably displaying
30 the three dimensional location of each amino acid, and more preferably displaying the three dimensional location of each atom of a G-CSF molecule;
 - (b) viewing said display;
 - (c) selecting a site on said display for
35 alteration in the composition of said molecule or the location of a moiety; and

- 128 -

(d) preparing a G-CSF analog with such alteration.

4. A computer-based method for preparing a G-CSF analog comprising the steps of:

5 (a) viewing the three dimensional structure of a G-CSF molecule via a computer, said computer having been previously programmed (i) to express the coordinates of a G-CSF molecule in three dimensional space, and (ii) to allow for entry of
10 information for alteration of said G-CSF expression and viewing thereof;

(b) selecting a site on said visual image of said G-CSF molecule for alteration;

(c) entering information for said
15 alteration on said computer;

(d) viewing a three dimensional structure of said altered G-CSF molecule via said computer;

(e) optionally repeating steps (a)-(e)
20 above;

(f) preparing a G-CSF analog with said alteration; and

(g) optionally testing said G-CSF analog for a desired characteristic.

25 5. In a computer-based apparatus for displaying the three dimensional structure of a molecule, the improvement comprising means for correlating said three dimensional structure of a G-CSF molecule with the composition of said G-CSF molecule.

30 6. A method for crystallization of a protein comprising the steps of:

(a) combining, optionally by automated means, aqueous aliquots of said protein with either (i) aliquots of a salt solution, each aliquot having a
35 different concentration of salt; or (ii) aliquots of a

- 129 -

precipitant solution, each aliquot having a different concentration of precipitant;

(b) selecting at least one of said combined aliquots, said selection based on the formation of precrystalline forms, or, if no precrystalline forms are so produced, increasing the protein starting concentration of said aqueous aliquots of protein and repeating step (a);

(c) after said salt or said precipitant concentration is selected, repeating step (a) with said previously unselected solution in the presence of said selected concentration; and,

(d) repeating step (b) and step (a) until a crystal of desired quality is obtained.

7. A method of claim 6 wherein each combination pursuant to step (a) is performed in a range of pH.

8. A method of claim 6 wherein said combining of step (a) is done in the presence of a nucleation initiation unit.

9. A G-CSF analog having an amino acid sequence different from that of Figure 1 in that:

(a) the N-terminal methionine is optional; and
(b) one or more of amino acids 58-72 (i) is substituted with one or more different amino acids or (ii) deleted; or (iii) chemically modified.

10. A G-CSF analog of claim 9 wherein said analog is more resistant to proteolysis than a G-CSF molecule of Figure 1.

11. A G-CSF analog of claim 10 wherein at least one of said amino acids is chemically modified by the addition of a polyethylene glycol molecule.

- 130 -

12. A G-CSF analog having an amino acid sequence different from that of Figure 1 in that:

(a) the N-terminal methionine is optional; and

5 (b) one or more of amino acids 119-125 (i) is substituted with one or more different amino acids or (ii) deleted; or (iii) chemically modified.

13. A G-CSF analog of claim 12 wherein said analog is more resistant to proteolysis than a G-CSF
10 molecule of Figure 1.

14 A G-CSF analog of claim 12 wherein at least one of said amino acids is chemically modified by the addition of a polyethylene glycol molecule.

15 15. A G-CSF molecule having the AB loop stabilized by connecting such loop to one or more of helices A, B, C, or D.

16. A G-CSF molecule having the CD loop stabilized by connecting such loop to one or more of helices A, B, C, or D.

20 17. A G-CSF analog, optionally in a pharmaceutically effective carrier, optionally in a pharmaceutically effective carrier, wherein the amino acid sequence differs from that of Figure 1 in that Lys¹⁷->Arg¹⁷ and the N-terminal methionine is optional.

25 18. A G-CSF analog, optionally in a pharmaceutically effective carrier, wherein the amino acid sequence differs from that of Figure 1 in that Lys³⁵->Arg³⁵ and the N-terminal methionine is optional.

30 19. A G-CSF analog, optionally in a pharmaceutically effective carrier, wherein the amino acid sequence differs from that of Figure 1 in that Lys⁴¹->Arg⁴¹ and the N-terminal methionine is optional.

35 20. A G-CSF analog, optionally in a pharmaceutically effective carrier, wherein the amino acid sequence differs from that of Figure 1 in that

- 131 -

Lys^{17,24,35}->Arg^{17,24,35} and the N-terminal methionine is optional.

21. A G-CSF analog, optionally in a pharmaceutically effective carrier, wherein the amino acid sequence differs from that of Figure 1 in that
5 Lys^{17,35,41}->Arg^{17,35,41} and the N-terminal methionine is optional.

22. A G-CSF analog, optionally in a pharmaceutically effective carrier, wherein the amino acid sequence differs from that of Figure 1 in that
10 Lys^{24,35,41}->Arg^{24,35,41} and the N-terminal methionine is optional.

23. A G-CSF analog, optionally in a pharmaceutically effective carrier, wherein the amino acid sequence differs from that of Figure 1 in that
15 Lys^{17,24,35,41} ->Arg^{17,24,35,41} and the N-terminal methionine is optional.

24. A G-CSF analog, optionally in a pharmaceutically effective carrier, wherein the amino acid sequence differs from that of Figure 1 in that
20 Lys^{17,24,41}->Arg^{17,24,41} and the N-terminal methionine is optional.

25. A G-CSF analog, optionally in a pharmaceutically effective carrier, wherein the amino acid sequence differs from that of Figure 1 in that
25 Gln⁶⁸->Glu⁶⁸ and the N-terminal methionine is optional.

26. A G-CSF analog, optionally in a pharmaceutically effective carrier, wherein the amino acid sequence differs from that of Figure 1 in that
30 Cys^{37,43}->Ser^{37,43} and the N-terminal methionine is optional.

27. A G-CSF analog, optionally in a pharmaceutically effective carrier, wherein the amino acid sequence differs from that of Figure 1 in that
35 Gln²⁶->Ala²⁶ and the N-terminal methionine is optional.

- 132 -

28. A G-CSF analog, optionally in a pharmaceutically effective carrier, wherein the amino acid sequence differs from that of Figure 1 in that Gln¹⁷⁴->Ala¹⁷⁴ and the N-terminal methionine is optional.

5 29. A G-CSF analog, optionally in a pharmaceutically effective carrier, wherein the amino acid sequence differs from that of Figure 1 in that Arg¹⁷⁰->Ala¹⁷⁰ and the N-terminal methionine is optional.

10 30. A G-CSF analog, optionally in a pharmaceutically effective carrier, wherein the amino acid sequence differs from that of Figure 1 in that Arg¹⁶⁷->Ala¹⁶⁷ and the N-terminal methionine is optional.

15 31. A G-CSF analog, optionally in a pharmaceutically effective carrier, wherein the amino acid sequence differs from that of Figure 1 in that there is a deletion at position 167 and the N-terminal methionine is optional.

20 32. A G-CSF analog, optionally in a pharmaceutically effective carrier, wherein the amino acid sequence differs from that of Figure 1 in that Lys⁴¹->Ala⁴¹ and the N-terminal methionine is optional.

25 33. A G-CSF analog, optionally in a pharmaceutically effective carrier, wherein the amino acid sequence differs from that of Figure 1 in that His⁴⁴->Lys⁴⁴ and the N-terminal methionine is optional.

34. A G-CSF analog, optionally in a pharmaceutically effective carrier, wherein the amino acid sequence differs from that of Figure 1 in that Glu⁴⁷->Ala⁴⁷ and the N-terminal methionine is optional.

30 35. A G-CSF analog, optionally in a pharmaceutically effective carrier, wherein the amino acid sequence differs from that of Figure 1 in that Arg²³->Ala²³ and the N-terminal methionine is optional.

35 36. A G-CSF analog, optionally in a pharmaceutically effective carrier, wherein the amino acid sequence differs from that of Figure 1 in that

- 133 -

Lys²⁴->Ala²⁴ and the N-terminal methionine is optional.

37. A G-CSF analog, optionally in a pharmaceutically effective carrier, wherein the amino acid sequence differs from that of Figure 1 in that
5 Glu²⁰->Ala²⁰ and the N-terminal methionine is optional.

38. A G-CSF analog, optionally in a pharmaceutically effective carrier, wherein the amino acid sequence differs from that of Figure 1 in that
Asp²⁸->Ala²⁸ and the N-terminal methionine is optional.

10 39. A G-CSF analog, optionally in a pharmaceutically effective carrier, wherein the amino acid sequence differs from that of Figure 1 in that
Met¹²⁷->Glu¹²⁷ and the N-terminal methionine is optional.

15 40. A G-CSF analog, optionally in a pharmaceutically effective carrier, wherein the amino acid sequence differs from that of Figure 1 in that
Met¹³⁸->Glu¹³⁸ and the N-terminal methionine is optional.

20 41. A G-CSF analog, optionally in a pharmaceutically effective carrier, wherein the amino acid sequence differs from that of Figure 1 in that
Met¹²⁷->Leu¹²⁷ and the N-terminal methionine is optional.

25 42. A G-CSF analog, optionally in a pharmaceutically effective carrier, wherein the amino acid sequence differs from that of Figure 1 in that
Met¹³⁸->Leu¹³⁸ and the N-terminal methionine is optional.

43. A G-CSF analog, optionally in a pharmaceutically effective carrier, wherein the amino acid sequence differs from that of Figure 1 in that
Cys¹⁸->Ala¹⁸ and the N-terminal methionine is optional.

30 44. A G-CSF analog, optionally in a pharmaceutically effective carrier, wherein the amino acid sequence differs from that of Figure 1 in that
Gln^{12,21}->Glu^{12,21} and the N-terminal methionine is optional.

35 45. A G-CSF analog, optionally in a pharmaceutically effective carrier, wherein the amino

- 134 -

acid sequence differs from that of Figure 1 in that Gln^{12,21,68}->Glu^{12,21,68} and the N-terminal methionine is optional.

46. A G-CSF analog, optionally in a
5 pharmaceutically effective carrier, wherein the amino acid sequence differs from that of Figure 1 in that Glu²⁰->Ala²⁰; Ser¹³->Gly¹³ and the N-terminal methionine is optional.

47. A G-CSF analog, optionally in a
10 pharmaceutically effective carrier, wherein the amino acid sequence differs from that of Figure 1 in that Met^{127,138}->Leu^{127,138} and the N-terminal methionine is optional.

48. A G-CSF analog, optionally in a
15 pharmaceutically effective carrier, wherein the amino acid sequence differs from that of Figure 1 in that Ser¹³->Ala¹³ and the N-terminal methionine is optional.

49. A G-CSF analog, optionally in a
20 pharmaceutically effective carrier, wherein the amino acid sequence differs from that of Figure 1 in that Lys¹⁷->Ala¹⁷ and the N-terminal methionine is optional.

50. A G-CSF analog, optionally in a
pharmaceutically effective carrier, wherein the amino acid sequence differs from that of Figure 1 in that
25 Gln¹²¹->Ala¹²¹ and the N-terminal methionine is optional.

51. A G-CSF analog, optionally in a
pharmaceutically effective carrier, wherein the amino acid sequence differs from that of Figure 1 in that
Gln²¹->Ala²¹ and the N-terminal methionine is optional.

52. A G-CSF analog, optionally in a
30 pharmaceutically effective carrier, wherein the amino acid sequence differs from that of Figure 1 in that His⁴⁴->Ala⁴⁴ and the N-terminal methionine is optional.

53. A G-CSF analog, optionally in a
35 pharmaceutically effective carrier, wherein said amino acid sequenc differs from that of Figure 1 in that

- 135 -

His⁵³->Ala⁵³ and the N-terminal methionine is optional.

54. A G-CSF analog, optionally in a pharmaceutically effective carrier, wherein the amino acid sequence differs from that of Figure 1 in that
5 Asp¹¹⁰->Ala¹¹⁰ and the N-terminal methionine is optional.

55. A G-CSF analog, optionally in a pharmaceutically effective carrier, wherein the amino acid sequence differs from that of Figure 1 in that
10 Asp¹¹³->Ala¹¹³ and the N-terminal methionine is optional.

56. A G-CSF analog, optionally in a pharmaceutically effective carrier, wherein the amino acid sequence differs from that of Figure 1 in that
10 Thr¹¹⁷->Ala¹¹⁷ and the N-terminal methionine is optional.

57. A G-CSF analog, optionally in a pharmaceutically effective carrier, wherein the amino acid sequence differs from that of Figure 1 in that
15 Asp²⁸->Ala²⁸; Asp¹¹⁰ ->Ala¹¹⁰ and the N-terminal methionine is optional.

58. A G-CSF analog, optionally in a pharmaceutically effective carrier, wherein the amino acid sequence differs from that of Figure 1 in that
20 Glu¹²⁴->Ala¹²⁴ and the N-terminal methionine is optional.

59. A G-CSF analog, optionally in a pharmaceutically effective carrier, wherein the amino acid sequence differs from that of Figure 1 in that
25 Phe¹¹⁴->Val¹¹⁴, Thr¹¹⁷->A¹¹⁷ and the N-terminal methionine is optional.

1/65

FIG.1

Met Thr Pro Leu Gly Pro Ala
TCTAGAAAAACCAAGGAGGTAATAAATA ATG ACT CCA TTA GGT CCT GCT

Ser Ser Leu Pro Gln Ser Phe Leu Leu Lys Cys Leu Glu Gln
TCT TCT CTG CCG CAA AGC TTT CTG CTG AAA TGT CTG GAA CAG

Val Arg Lys Ile Gln Gly Asp Gly Ala Ala Leu Gln Glu Lys Leu
GTT CGT AAA ATC CAG GGT GAC GGT GCT GCA CTG CAA GAA AAA CTG

Cys Ala Thr Tyr Lys Leu Cys His Pro Glu Glu Leu Val Leu Leu
TGC GCT ACT TAC AAA CTG TGC CAT CCG GAA GAG CTG GTA CTG CTG

Gly His Ser Leu Gly Ile Pro Trp Ala Pro Leu Ser Ser Cys Pro
GGT CAT TCT CTT GGG ATC CCG TGG GCT CCG CTG TCT TCT TGT CCA

Ser Gln Ala Leu Gln Leu Ala Gly Cys Leu Ser Gln Leu His Ser
TCT CAA GCT CTT CAG CTG GCT GGT TGT CTG TCT CAA CTG CAT TCT

Gly Leu Phe Leu Tyr Gln Gly Leu Leu Gln Ala Leu Glu Gly Ile
GGT CTG TTC CTG TAT CAG GGT CTT CTG CAA GCT CTG GAA GGT ATC

Ser Pro Glu Leu Gly Pro Thr Leu Asp Thr Leu Gln Leu Asp Val
TCT CCG GAA CTG GGT CCG ACT CTG GAC ACT CTG CAG CTA GAT GTA

Ala Asp Phe Ala Thr Thr Ile Trp Gln Gln Met Glu Glu Leu Gly
GCT GAC TTT GCT ACT ACT ATT TGG CAA CAG ATG GAA GAG CTC GGT

Met Ala Pro Ala Leu Gln Pro Thr Gln Gly Ala Met Pro Ala Phe
ATG GCA CCA GCT CTG CAA CCG ACT CAA GGT GCT ATG CCG GCA TTC

Ala Ser Ala Phe Gln Arg Arg Ala Gly Gly Val Leu Val Ala Ser
GCT TCT GCA TTC CAG CGT CGT GCA GGA GGT GTA CTG GTT GCT TCT

His Leu Gln Ser Phe Leu Glu Val Ser Tyr Arg Val Leu Arg His
CAT CTG CAA TCT TTC CTG GAA GTA TCT TAC CGT GTT CTG CGT CAT

Leu Ala Gln Pro OC AM
CTG GCT CAG CCG TAA TAG AATTC

FIG. 2A
rhG-CSF

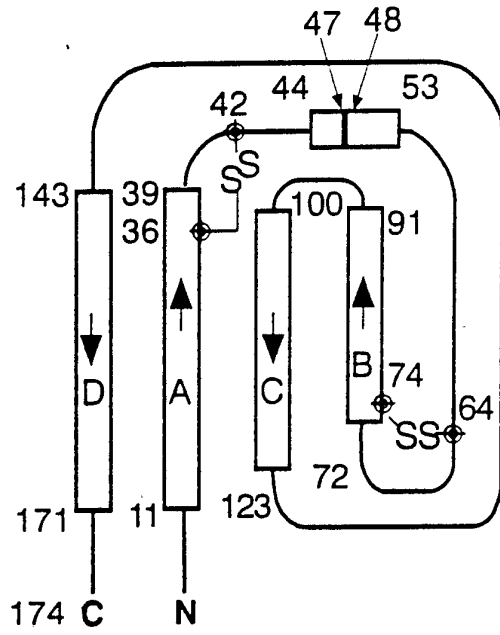
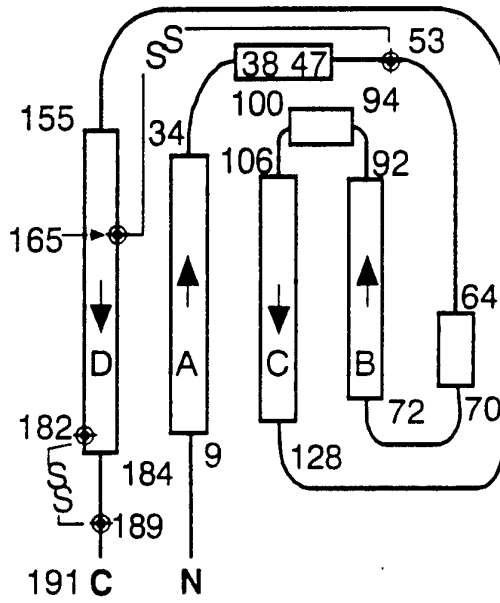

FIG. 2B
hGH



3/65

FIG. 2C
pGH

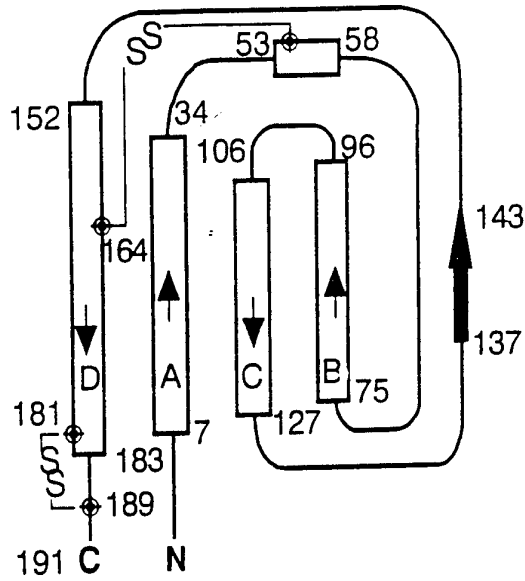

FIG. 2D
GM-CSF

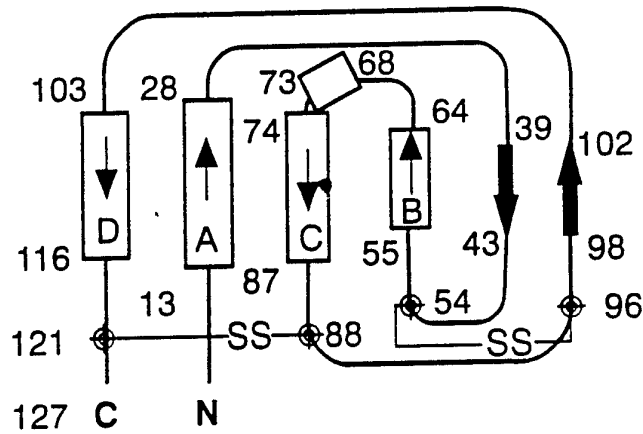

FIG. 2E
INF-B

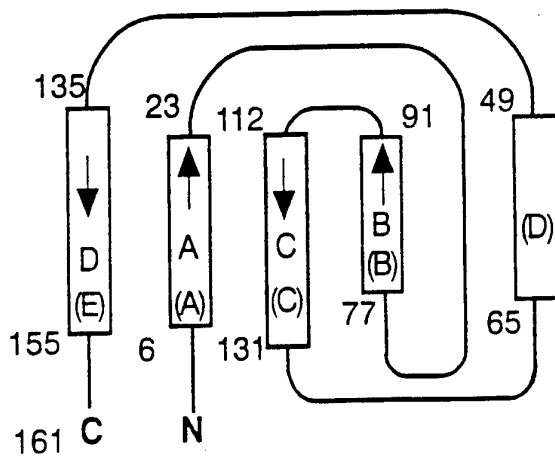

FIG. 2F
IL-2

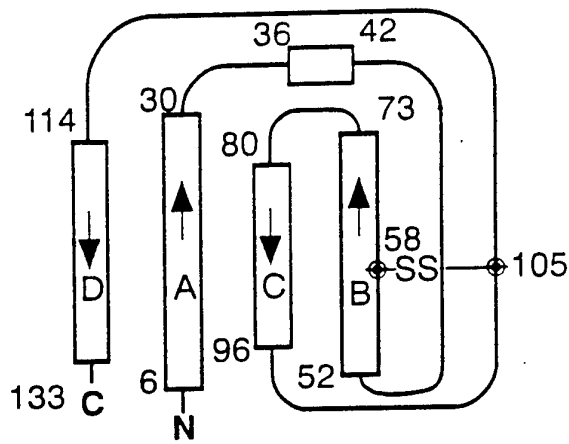
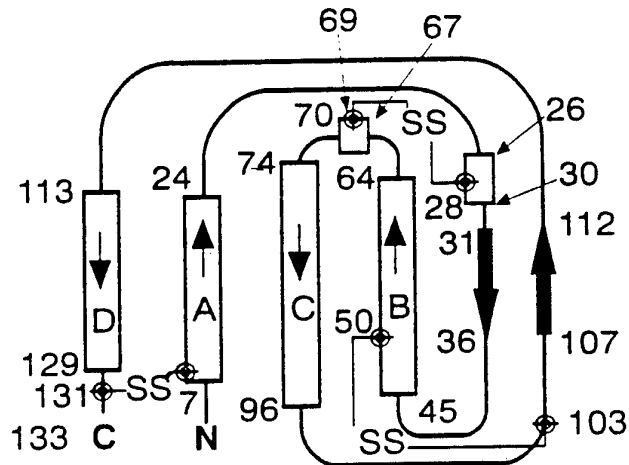
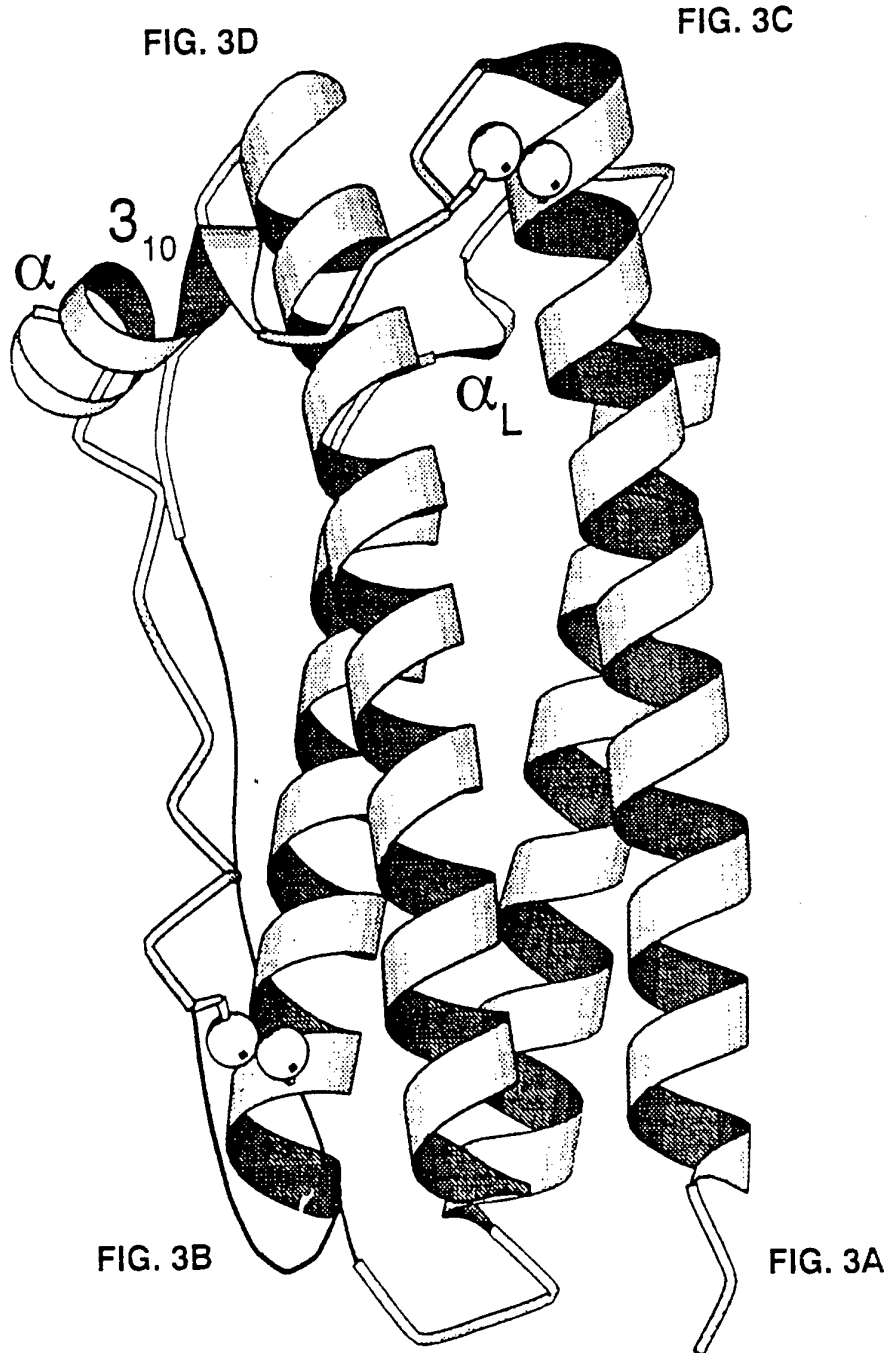

FIG. 2G
IL-4





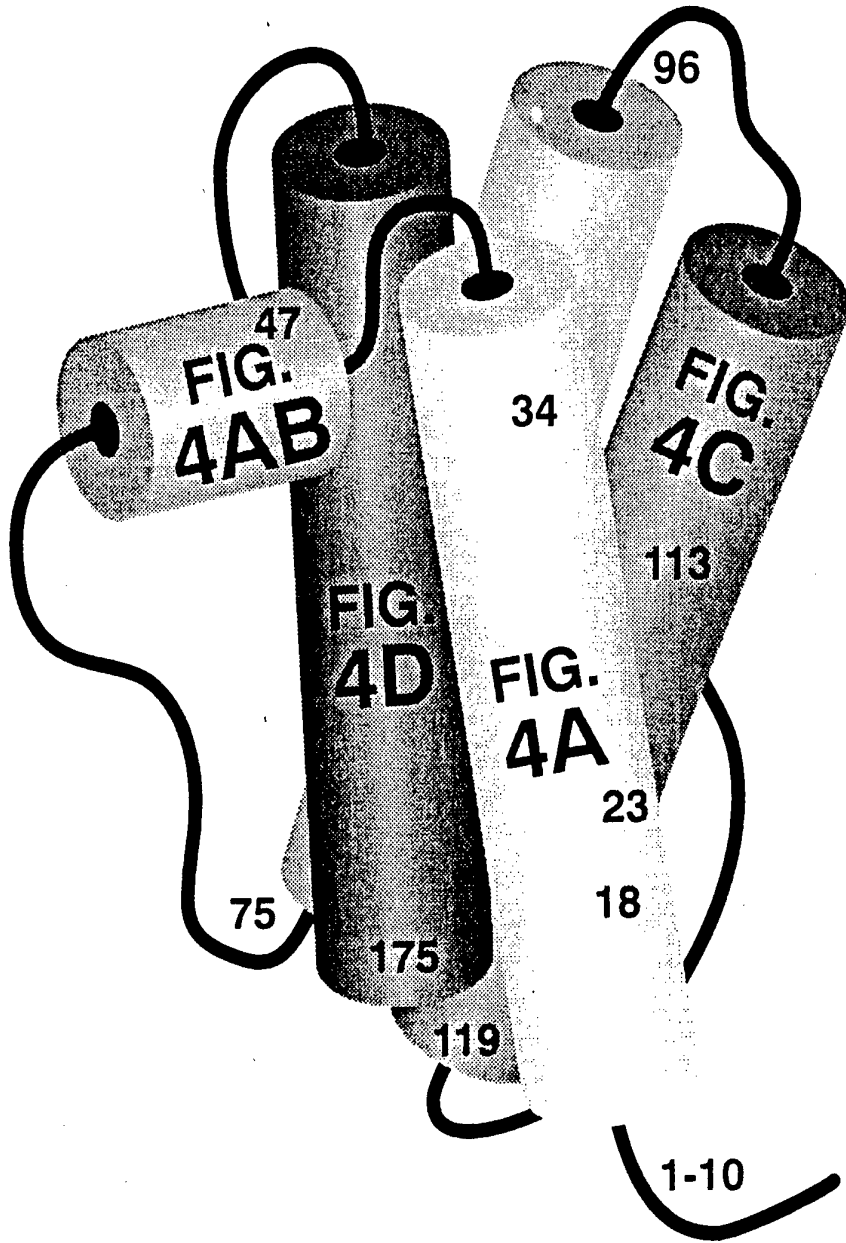

FIG. 5A

ATOM	1	CB LEU	10	58.751	58.191	-14.868	1.00	61.22	A1	ATOM	35	OG SER	13	61.702	53.493	-5.362	1.00	56.64	A1
ATOM	2	CG LEU	10	58.360	59.271	-13.939	1.00	60.19	A1	ATOM	36	HC SER	13	61.534	52.551	-5.477	1.00	0.00	A1
ATOM	3	CD1 LEU	10	59.307	60.461	-14.022	1.00	60.14	A1	ATOM	37	C SER	13	59.497	55.214	-6.900	1.00	52.58	A1
ATOM	4	CD2 LEU	10	56.954	59.658	-14.335	1.00	60.68	A1	ATOM	38	O SER	13	58.509	55.144	-6.160	1.00	53.55	A1
ATOM	5	C LEU	10	60.544	56.734	-13.849	1.00	62.85	A1	ATOM	39	N PHE	14	59.791	56.333	-7.577	1.00	50.84	A1
ATOM	6	O LEU	10	60.079	55.595	-14.041	1.00	63.08	A1	ATOM	40	H PHE	14	60.469	56.292	-8.279	1.00	0.00	A1
ATOM	7	HT1 LEU	10	59.876	56.135	-15.998	1.00	0.00	A1	ATOM	41	CA PHE	14	59.067	57.590	-7.423	1.00	47.21	A1
ATOM	8	HT2 LEU	10	61.323	56.887	-16.434	1.00	0.00	A1	ATOM	42	CB PHE	14	59.611	58.590	-8.454	1.00	44.68	A1
ATOM	9	N LEU	10	60.328	57.059	-16.204	1.00	62.24	A1	ATOM	43	CG PHE	14	58.618	59.669	-8.866	1.00	42.88	A1
ATOM	10	HT3 LEU	10	59.817	57.535	-16.971	1.00	0.00	A1	ATOM	44	CD1 PHE	14	58.052	59.594	-10.123	1.00	40.40	A1
ATOM	11	CA LEU	10	60.183	57.758	-14.941	1.00	62.58	A1	ATOM	45	CD2 PHE	14	58.264	60.673	-7.978	1.00	40.30	A1
ATOM	12	N PRO	11	61.357	56.962	-12.780	1.00	61.96	A1	ATOM	46	CE1 PHE	14	57.114	60.518	-10.507	1.00	39.59	A1
ATOM	13	CD PRO	11	61.960	58.238	-12.383	1.00	61.21	A1	ATOM	47	CE2 PHE	14	57.329	61.587	-8.380	1.00	41.82	A1
ATOM	14	CA PRO	11	61.832	55.889	-11.906	1.00	61.34	A1	ATOM	48	CZ PHE	14	56.751	61.515	-9.635	1.00	41.56	A1
ATOM	15	CB PRO	11	62.915	56.547	-11.043	1.00	59.77	A1	ATOM	49	C PHE	14	57.605	57.263	-7.661	1.00	45.83	A1
ATOM	16	CG PRO	11	62.511	57.983	-10.975	1.00	59.16	A1	ATOM	50	O PHE	14	56.789	57.588	-6.805	1.00	46.07	A1
ATOM	17	C PRO	11	60.712	55.225	-11.109	1.00	60.68	A1	ATOM	51	N LEU	15	57.298	56.509	-8.718	1.00	44.64	A1
ATOM	18	O PRO	11	60.075	55.843	-10.250	1.00	61.73	A1	ATOM	52	H LEU	15	58.024	56.183	-9.287	1.00	0.00	A1
ATOM	19	N GLN	12	60.466	53.946	-11.407	1.00	59.31	A1	ATOM	53	CA LEU	15	55.940	56.181	-9.038	1.00	44.53	A1
ATOM	20	H GLN	12	60.944	53.573	-12.175	1.00	0.00	A1	ATOM	54	CB LEU	15	55.858	55.402	-10.300	1.00	48.74	A1
ATOM	21	CA GLN	12	59.468	53.121	-10.743	1.00	57.22	A1	ATOM	55	CG LEU	15	54.853	53.013	-11.289	1.00	51.65	A1
ATOM	22	CB GLN	12	59.779	51.646	-10.970	1.00	59.27	A1	ATOM	56	CD1 LEU	15	55.525	57.121	-12.105	1.00	50.33	A1
ATOM	23	CG GLN	12	58.620	50.714	-10.591	1.00	59.70	A1	ATOM	57	CD2 LEU	15	54.320	54.906	-12.204	1.00	53.77	A1
ATOM	24	CD GLN	12	57.604	50.575	-11.702	1.00	61.71	A1	ATOM	58	C LEU	15	55.169	55.410	-8.014	1.00	44.07	A1
ATOM	25	OE1 GLN	12	57.170	49.465	-11.970	1.00	65.82	A1	ATOM	59	O LEU	15	53.945	55.567	-7.959	1.00	45.46	A1
ATOM	26	NE2 GLN	12	57.227	51.534	-12.541	1.00	63.02	A1	ATOM	60	N LEU	16	55.809	54.620	-7.166	1.00	43.18	A1
ATOM	27	HE21 GLN	12	57.639	52.419	-12.489	1.00	0.00	A1	ATOM	61	H LEU	16	56.781	54.503	-7.251	1.00	0.00	A1
ATOM	28	HE22 GLN	12	56.500	51.308	-13.156	1.00	0.00	A1	ATOM	62	CA LEU	16	55.110	53.913	-6.095	1.00	42.96	A1
ATOM	29	C GLN	12	59.336	53.347	-9.245	1.00	55.34	A1	ATOM	63	CB LEU	16	55.866	52.623	-5.751	1.00	43.34	A1
ATOM	30	O GLN	12	58.242	53.196	-8.708	1.00	54.56	A1	ATOM	64	CG LEU	16	55.840	51.608	-6.868	1.00	42.25	A1
ATOM	31	N SER	13	60.423	53.732	-8.576	1.00	53.44	A1	ATOM	65	CD1 LEU	16	56.889	50.567	-6.596	1.00	43.68	A1
ATOM	32	H SER	13	61.276	53.839	-9.033	1.00	0.00	A1	ATOM	66	CD2 LEU	16	54.413	51.068	-7.030	1.00	42.75	A1
ATOM	33	CA SER	13	60.335	53.974	-7.168	1.00	52.86	A1	ATOM	67	C LEU	16	54.963	54.778	-4.852	1.00	42.35	A1
ATOM	34	CB SER	13	61.704	54.144	-6.626	1.00	52.24	A1	ATOM	68	O LEU	16	54.077	54.579	-4.018	1.00	42.65	A1
										ATOM	69	N LYS	17	55.823	55.779	-4.703	1.00	42.47	A1
										ATOM	70	H LYS	17	56.587	55.840	-5.320	1.00	0.00	A1

FIG. 5B

ATOM	71	CA	LYS	17	55.681	56.767	-3.650	1.00	42.07	A1
ATOM	72	CB	LYS	17	56.995	57.554	-3.573	1.00	44.14	A1
ATOM	73	CG	LYS	17	57.214	58.197	-2.223	1.00	49.61	A1
ATOM	74	CD	LYS	17	57.114	57.164	-1.086	1.00	55.15	A1
ATOM	75	CE	LYS	17	56.747	57.804	0.293	1.00	62.05	A1
ATOM	76	NZ	LYS	17	55.462	58.533	0.331	1.00	65.43	A1
ATOM	77	HZ1	LYS	17	54.684	57.884	0.098	1.00	0.00	A1
ATOM	78	HZ2	LYS	17	55.482	59.308	-0.362	1.00	0.00	A1
ATOM	79	HZ3	LYS	17	55.312	58.926	1.282	1.00	0.00	A1
ATOM	80	C	LYS	17	54.463	57.640	-4.051	1.00	41.20	A1
ATOM	81	O	LYS	17	53.648	57.999	-3.186	1.00	40.66	A1
ATOM	82	N	CYS	18	54.272	57.992	-5.346	1.00	39.13	A1
ATOM	83	H	CYS	18	54.998	57.809	-5.981	1.00	0.00	A1
ATOM	84	CA	CYS	18	53.080	58.656	-5.802	1.00	37.42	A1
ATOM	85	CB	CYS	18	53.092	58.891	-7.261	1.00	35.02	A1
ATOM	86	SG	CYS	18	54.421	60.026	-7.681	1.00	40.40	A1
ATOM	87	C	CYS	18	51.859	57.789	-5.502	1.00	39.33	A1
ATOM	88	O	CYS	18	50.959	58.346	-4.847	1.00	40.83	A1
ATOM	89	N	LEU	19	51.738	56.475	-5.842	1.00	37.15	A1
ATOM	90	H	LEU	19	52.462	56.038	-6.341	1.00	0.00	A1
ATOM	91	CA	LEU	19	50.521	55.702	-5.534	1.00	36.00	A1
ATOM	92	CB	LEU	19	50.644	54.204	-5.947	1.00	38.31	A1
ATOM	93	CG	LEU	19	49.410	53.271	-5.657	1.00	40.86	A1
ATOM	94	CD1	LEU	19	48.208	53.684	-6.467	1.00	39.71	A1
ATOM	95	CD2	LEU	19	49.692	51.833	-6.113	1.00	45.71	A1
ATOM	96	C	LEU	19	50.102	55.736	-4.076	1.00	33.52	A1
ATOM	97	O	LEU	19	48.930	55.949	-3.766	1.00	32.75	A1
ATOM	98	N	GLU	20	51.030	55.576	-3.166	1.00	31.88	A1
ATOM	99	H	GLU	20	51.940	55.338	-3.455	1.00	0.00	A1
ATOM	100	CA	GLU	20	50.750	55.710	-1.748	1.00	33.40	A1
ATOM	101	CB	GLU	20	52.053	55.334	-1.167	1.00	35.25	A1
ATOM	102	CG	GLU	20	52.508	55.504	0.260	1.00	43.21	A1
ATOM	103	CD	GLU	20	53.948	54.947	0.407	1.00	51.06	A1
ATOM	104	OE1	GLU	20	54.320	54.660	1.546	1.00	56.78	A1
ATOM	105	OE2	GLU	20	54.708	54.766	-0.570	1.00	51.57	A1
ATOM	106	C	GLU	20	50.230	57.117	-1.326	1.00	33.25	A1
ATOM	107	O	GLU	20	49.432	57.291	-0.380	1.00	33.30	A1
ATOM	108	N	GLN	21	50.660	58.167	-2.044	1.00	32.33	A1
ATOM	109	H	GLN	21	51.270	58.004	-2.794	1.00	0.00	A1
ATOM	110	CA	GLN	21	50.275	59.538	-1.742	1.00	31.00	A1
ATOM	111	CB	GLN	21	51.326	60.489	-2.340	1.00	32.37	A1
ATOM	112	CG	GLN	21	52.436	60.530	-1.272	1.00	38.01	A1
ATOM	113	CD	GLN	21	53.622	61.460	-1.504	1.00	42.67	A1
ATOM	114	OE1	GLN	21	54.008	62.236	-0.615	1.00	43.63	A1
ATOM	115	NE2	GLN	21	54.256	61.448	-2.678	1.00	42.31	A1
ATOM	116	HE21	GLN	21	53.965	60.840	-3.384	1.00	0.00	A1
ATOM	117	HE22	GLN	21	55.026	62.052	-2.730	1.00	0.00	A1
ATOM	118	C	GLN	21	48.894	59.765	-2.288	1.00	28.51	A1
ATOM	119	O	GLN	21	48.027	60.242	-1.563	1.00	28.65	A1
ATOM	120	N	VAL	22	48.682	59.319	-3.521	1.00	25.85	A1
ATOM	121	H	VAL	22	49.448	58.980	-4.013	1.00	0.00	A1
ATOM	122	CA	VAL	22	47.382	59.303	-4.161	1.00	24.94	A1
ATOM	123	CB	VAL	22	47.508	58.614	-5.526	1.00	24.09	A1
ATOM	124	CG1	VAL	22	46.154	58.378	-6.096	1.00	19.97	A1
ATOM	125	CG2	VAL	22	48.252	59.479	-6.498	1.00	25.82	A1
ATOM	126	C	VAL	22	46.418	58.549	-3.226	1.00	25.65	A1
ATOM	127	O	VAL	22	45.428	59.190	-2.800	1.00	29.31	A1
ATOM	128	N	ARG	23	46.643	57.291	-2.759	1.00	23.93	A1
ATOM	129	H	ARG	23	47.440	56.819	-3.075	1.00	0.00	A1
ATOM	130	CA	ARG	23	45.667	56.593	-1.892	1.00	20.67	A1
ATOM	131	CB	ARG	23	46.104	55.135	-1.635	1.00	20.45	A1
ATOM	132	CG	ARG	23	46.325	54.321	-2.904	1.00	17.51	A1
ATOM	133	CD	ARG	23	45.095	54.446	-3.769	1.00	21.54	A1
ATOM	134	NE	ARG	23	45.076	53.437	-4.809	1.00	24.82	A1
ATOM	135	HE	ARG	23	45.642	52.647	-4.701	1.00	0.00	A1
ATOM	136	CZ	ARG	23	44.323	53.556	-5.904	1.00	27.69	A1
ATOM	137	NH1	ARG	23	43.567	54.669	-6.006	1.00	29.51	A1
ATOM	138	HH11	ARG	23	43.562	55.377	-5.303	1.00	0.00	A1
ATOM	139	HH12	ARG	23	42.956	54.730	-6.789	1.00	0.00	A1
ATOM	140	NH2	ARG	23	44.345	52.604	-6.891	1.00	24.22	A1
ATOM	141	HH21	ARG	23	43.780	52.713	-7.709	1.00	0.00	A1
ATOM	142	HH22	ARG	23	44.936	51.802	-6.793	1.00	0.00	A1

FIG. 5C

ATOM	143	C	ARG	23	45.458	57.285	-0.560	1.00	20.56	A1
ATOM	144	O	ARG	23	44.374	57.254	0.042	1.00	20.04	A1
ATOM	145	N	LYS	24	46.485	58.015	-0.118	1.00	22.67	A1
ATOM	146	H	LYS	24	47.291	58.105	-0.668	1.00	0.00	A1
ATOM	147	CA	LYS	24	46.431	58.729	1.166	1.00	22.85	A1
ATOM	148	CB	LYS	24	47.811	59.255	1.506	1.00	26.86	A1
ATOM	149	CG	LYS	24	47.821	59.661	2.971	1.00	33.79	A1
ATOM	150	CD	LYS	24	49.121	60.265	3.404	1.00	40.73	A1
ATOM	151	CE	LYS	24	50.258	59.258	3.335	1.00	46.19	A1
ATOM	152	NZ	LYS	24	51.532	59.975	3.333	1.00	51.19	A1
ATOM	153	HZ1	LYS	24	51.637	60.498	4.225	1.00	0.00	A1
ATOM	154	HZ2	LYS	24	51.539	60.651	2.539	1.00	0.00	A1
ATOM	155	HZ3	LYS	24	52.317	59.303	3.216	1.00	0.00	A1
ATOM	156	C	LYS	24	45.455	59.893	1.101	1.00	21.66	A1
ATOM	157	O	LYS	24	44.588	60.068	1.962	1.00	20.90	A1
ATOM	158	N	ILE	25	45.549	60.696	0.044	1.00	21.66	A1
ATOM	159	H	ILE	25	46.242	60.509	-0.629	1.00	0.00	A1
ATOM	160	CA	ILE	25	44.667	61.841	-0.115	1.00	22.53	A1
ATOM	161	CB	ILE	25	45.075	62.694	-1.307	1.00	22.15	A1
ATOM	162	CG2	ILE	25	44.097	63.834	-1.439	1.00	20.44	A1
ATOM	163	CG1	ILE	25	46.475	63.230	-1.136	1.00	21.03	A1
ATOM	164	CD	ILE	25	47.188	63.281	-2.497	1.00	20.03	A1
ATOM	165	C	ILE	25	43.263	61.308	-0.352	1.00	24.75	A1
ATOM	166	O	ILE	25	42.339	61.839	0.301	1.00	26.13	A1
ATOM	167	N	GLN	26	43.065	60.289	-1.244	1.00	22.79	A1
ATOM	168	H	GLN	26	43.842	59.926	-1.726	1.00	0.00	A1
ATOM	169	CA	GLN	26	41.737	59.713	-1.437	1.00	20.12	A1
ATOM	170	CB	GLN	26	41.729	58.539	-2.341	1.00	18.89	A1
ATOM	171	CG	GLN	26	42.203	59.042	-3.627	1.00	19.77	A1
ATOM	172	CD	GLN	26	42.163	57.996	-4.684	1.00	24.26	A1
ATOM	173	OE1	GLN	26	42.550	56.853	-4.465	1.00	26.82	A1
ATOM	174	NE2	GLN	26	41.732	58.351	-5.890	1.00	27.68	A1
ATOM	175	HE21	GLN	26	41.421	59.265	-6.042	1.00	0.00	A1
ATOM	176	HE22	GLN	26	41.743	57.649	-6.552	1.00	0.00	A1
ATOM	177	C	GLN	26	41.207	59.239	-0.111	1.00	21.88	A1
ATOM	178	O	GLN	26	40.067	59.550	0.220	1.00	27.02	A1
ATOM	179	N	GLY	27	41.952	58.622	0.773	1.00	22.54	A1
ATOM	180	H	GLY	27	42.891	58.420	0.576	1.00	0.00	A1
ATOM	181	CA	GLY	27	41.386	58.191	2.037	1.00	25.55	A1
ATOM	182	C	GLY	27	40.936	59.352	2.890	1.00	27.80	A1
ATOM	183	O	GLY	27	39.889	59.251	3.526	1.00	29.95	A1
ATOM	184	N	ASP	28	41.683	60.460	2.915	1.00	29.39	A1
ATOM	185	H	ASP	28	42.547	60.454	2.448	1.00	0.00	A1
ATOM	186	CA	ASP	28	41.257	61.680	3.624	1.00	28.45	A1
ATOM	187	CB	ASP	28	42.266	62.789	3.552	1.00	30.13	A1
ATOM	188	CG	ASP	28	43.737	62.502	3.777	1.00	31.72	A1
ATOM	189	OD1	ASP	28	44.539	63.024	2.995	1.00	31.95	A1
ATOM	190	OD2	ASP	28	44.063	61.811	4.741	1.00	32.00	A1
ATOM	191	C	ASP	28	39.994	62.264	2.960	1.00	25.81	A1
ATOM	192	O	ASP	28	39.101	62.699	3.655	1.00	26.21	A1
ATOM	193	N	GLY	29	39.882	62.270	1.631	1.00	23.93	A1
ATOM	194	H	GLY	29	40.660	61.950	1.135	1.00	0.00	A1
ATOM	195	CA	GLY	29	38.729	62.694	0.886	1.00	25.69	A1
ATOM	196	C	GLY	29	37.528	61.961	1.418	1.00	27.36	A1
ATOM	197	O	GLY	29	36.648	62.558	2.061	1.00	28.14	A1
ATOM	198	N	ALA	30	37.646	60.628	1.295	1.00	27.85	A1
ATOM	199	H	ALA	30	38.442	60.288	0.843	1.00	0.00	A1
ATOM	200	CA	ALA	30	36.683	59.655	1.814	1.00	25.94	A1
ATOM	201	CB	ALA	30	37.269	58.303	1.556	1.00	22.15	A1
ATOM	202	C	ALA	30	36.356	59.842	3.308	1.00	27.18	A1
ATOM	203	O	ALA	30	35.194	59.772	3.754	1.00	28.82	A1
ATOM	204	N	ALA	31	37.340	60.105	4.150	1.00	27.16	A1
ATOM	205	H	ALA	31	38.253	60.114	3.809	1.00	0.00	A1
ATOM	206	CA	ALA	31	37.113	60.470	5.531	1.00	27.70	A1
ATOM	207	CB	ALA	31	38.383	60.881	6.177	1.00	27.65	A1
ATOM	208	C	ALA	31	36.178	61.675	5.660	1.00	30.01	A1
ATOM	209	O	ALA	31	35.195	61.624	6.413	1.00	32.91	A1
ATOM	210	N	LEU	32	36.397	62.744	4.895	1.00	27.63	A1
ATOM	211	H	LEU	32	37.133	62.734	4.242	1.00	0.00	A1
ATOM	212	CA	LEU	32	35.560	63.898	4.997	1.00	28.52	A1
ATOM	213	CB	LEU	32	36.226	65.019	4.167	1.00	32.94	A1
ATOM	214	CG	LEU	32	35.658	66.472	4.091	1.00	32.54	A1

FIG. 5D

ATOM	215	CD1 LEU	32	35.516	67.082	5.499	1.00	32.87	A1	ATOM	251	HZ3 LYS	35	36.477	61.405	12.119	1.00	0.00	A1
ATOM	216	CD2 LEU	32	36.555	67.267	3.181	1.00	30.97	A1	ATOM	252	C LYS	35	30.630	63.660	7.697	1.00	44.45	A1
ATOM	217	C LEU	32	34.133	63.597	4.518	1.00	27.87	A1	ATOM	253	O LYS	35	29.730	63.999	8.478	1.00	44.61	A1
ATOM	218	O LEU	32	33.169	63.889	5.250	1.00	25.93	A1	ATOM	254	N LEU	36	30.652	64.190	6.480	1.00	41.21	A1
ATOM	219	N GLN	33	33.977	63.028	3.315	1.00	27.51	A1	ATOM	255	H LEU	36	31.343	63.930	5.836	1.00	0.00	A1
ATOM	220	H GLN	33	34.787	62.826	2.802	1.00	0.00	A1	ATOM	256	CA LEU	36	29.647	65.157	6.144	1.00	40.25	A1
ATOM	221	CA GLN	33	32.687	62.671	2.775	1.00	30.40	A1	ATOM	257	CB LEU	36	30.070	65.899	4.889	1.00	39.03	A1
ATOM	222	CB GLN	33	32.737	61.721	1.614	1.00	29.47	A1	ATOM	258	CG LEU	36	31.253	66.834	4.935	1.00	33.99	A1
ATOM	223	CG GLN	33	32.888	62.584	0.436	1.00	29.26	A1	ATOM	259	CD1 LEU	36	31.438	67.404	3.571	1.00	32.08	A1
ATOM	224	CD GLN	33	33.015	61.869	-0.887	1.00	30.21	A1	ATOM	260	CD2 LEU	36	31.034	67.939	5.928	1.00	35.05	A1
ATOM	225	OE1 GLN	33	34.064	61.495	-1.452	1.00	29.61	A1	ATOM	261	C LEU	36	28.332	64.414	5.941	1.00	41.90	A1
ATOM	226	NE2 GLN	33	31.823	61.759	-1.426	1.00	33.19	A1	ATOM	262	O LEU	36	27.267	64.828	6.431	1.00	42.30	A1
ATOM	227	HE21 GLN	33	31.781	61.328	-2.302	1.00	0.00	A1	ATOM	263	N CYS	37	28.392	63.251	5.309	1.00	42.63	A1
ATOM	228	HE22 GLN	33	31.042	62.060	-0.914	1.00	0.00	A1	ATOM	264	H CYS	37	29.250	62.904	5.020	1.00	0.00	A1
ATOM	229	C GLN	33	31.839	61.963	3.788	1.00	35.60	A1	ATOM	265	CA CYS	37	27.216	62.469	5.084	1.00	43.53	A1
ATOM	230	O GLN	33	30.715	62.416	4.073	1.00	36.49	A1	ATOM	266	C CYS	37	26.638	62.026	6.362	1.00	44.65	A1
ATOM	231	N GLU	34	32.386	60.925	4.438	1.00	39.81	A1	ATOM	267	O CYS	37	25.426	61.997	6.459	1.00	46.40	A1
ATOM	232	H GLU	34	33.340	60.707	4.328	1.00	0.00	A1	ATOM	268	CB CYS	37	27.474	61.240	4.313	1.00	44.60	A1
ATOM	233	CA GLU	34	31.541	60.131	5.304	1.00	43.24	A1	ATOM	269	SG CYS	37	26.133	60.038	4.530	1.00	43.86	A1
ATOM	234	CB GLU	34	32.228	58.792	5.571	1.00	46.46	A1	ATOM	270	N ALA	38	27.465	61.734	7.342	1.00	45.96	A1
ATOM	235	CG GLU	34	33.274	58.721	6.624	1.00	55.01	A1	ATOM	271	H ALA	38	28.433	61.707	7.202	1.00	0.00	A1
ATOM	236	CD GLU	34	32.777	58.092	7.930	1.00	60.29	A1	ATOM	272	CA ALA	38	26.932	61.261	8.592	1.00	48.03	A1
ATOM	237	OE1 GLU	34	33.483	57.186	8.412	1.00	63.26	A1	ATOM	273	CB ALA	38	27.869	60.140	9.108	1.00	48.64	A1
ATOM	238	OE2 GLU	34	31.724	58.504	8.459	1.00	60.44	A1	ATOM	274	C ALA	38	26.748	62.358	9.624	1.00	48.89	A1
ATOM	239	C GLU	34	31.218	60.877	6.564	1.00	43.59	A1	ATOM	275	O ALA	38	26.103	62.085	10.621	1.00	50.72	A1
ATOM	240	O GLU	34	30.175	60.631	7.161	1.00	44.87	A1	ATOM	276	N THR	39	27.256	63.590	9.512	1.00	50.66	A1
ATOM	241	N LYS	35	32.045	61.811	6.998	1.00	44.80	A1	ATOM	277	H THR	39	27.858	63.780	8.770	1.00	0.00	A1
ATOM	242	H LYS	35	32.923	61.931	6.569	1.00	0.00	A1	ATOM	278	CA THR	39	26.976	64.638	10.503	1.00	51.54	A1
ATOM	243	CA LYS	35	31.674	62.634	8.134	1.00	45.43	A1	ATOM	279	CB THR	39	28.179	65.593	10.690	1.00	51.76	A1
ATOM	244	CB LYS	35	32.881	63.364	8.686	1.00	47.67	A1	ATOM	280	OG1 THR	39	29.294	64.826	11.126	1.00	52.65	A1
ATOM	245	CG LYS	35	33.701	62.414	9.510	1.00	52.75	A1	ATOM	281	HG1 THR	39	29.749	64.481	10.355	1.00	0.00	A1
ATOM	246	CD LYS	35	35.084	63.021	9.548	1.00	57.55	A1	ATOM	282	CG2 THR	39	27.900	66.655	11.729	1.00	51.62	A1
ATOM	247	CE LYS	35	36.067	62.099	10.238	1.00	60.35	A1	ATOM	283	C THR	39	25.775	65.466	10.037	1.00	52.17	A1
ATOM	248	NZ LYS	35	35.810	62.064	11.669	1.00	62.91	A1	ATOM	284	O THR	39	24.886	65.882	10.781	1.00	52.15	A1
ATOM	249	HZ1 LYS	35	34.838	61.733	11.840	1.00	0.00	A1	ATOM	285	N TYR	40	25.751	65.720	8.738	1.00	52.83	A1
ATOM	250	HZ2 LYS	35	35.930	63.011	12.078	1.00	0.00	A1	ATOM	286	H TYR	40	26.420	65.331	8.139	1.00	0.00	A1

11/65

FIG. 5E

ATOM	287	CA	TYR	40	24.729	66.561	8.165	1.00	52.53	A1	ATOM	323	CA	CYS	43	25.480	61.951	1.358	1.00	42.87	A1
ATOM	288	CB	TYR	40	25.314	67.872	7.696	1.00	52.15	A1	ATOM	324	C	CYS	43	25.448	61.846	-0.123	1.00	41.62	A1
ATOM	289	CG	TYR	40	26.399	68.458	8.552	1.00	54.11	A1	ATOM	325	O	CYS	43	25.762	60.805	-0.666	1.00	41.99	A1
ATOM	290	CD1	TYR	40	27.678	68.341	8.062	1.00	56.50	A1	ATOM	326	CB	CYS	43	24.716	60.796	2.026	1.00	41.77	A1
ATOM	291	CE1	TYR	40	28.719	68.934	8.724	1.00	58.28	A1	ATOM	327	SG	CYS	43	24.523	61.011	3.835	1.00	45.91	A1
ATOM	292	CD2	TYR	40	26.122	69.144	9.714	1.00	54.86	A1	ATOM	328	N	HIS	44	25.057	62.846	-0.882	1.00	42.90	A1
ATOM	293	CE2	TYR	40	27.170	69.746	10.378	1.00	56.20	A1	ATOM	329	H	HIS	44	24.841	63.721	-0.491	1.00	0.00	A1
ATOM	294	CZ	TYR	40	28.453	69.642	9.872	1.00	58.26	A1	ATOM	330	CA	HIS	44	25.069	62.680	-2.320	1.00	44.60	A1
ATOM	295	OH	TYR	40	29.513	70.310	10.463	1.00	61.00	A1	ATOM	331	CB	HIS	44	23.653	62.264	-2.825	1.00	48.40	A1
ATOM	296	HH	TYR	40	30.179	70.443	9.782	1.00	0.00	A1	ATOM	332	CG	HIS	44	23.085	60.935	-2.310	1.00	50.37	A1
ATOM	297	C	TYR	40	24.035	65.911	6.981	1.00	51.75	A1	ATOM	333	CD2	HIS	44	22.178	60.844	-1.272	1.00	50.52	A1
ATOM	298	O	TYR	40	23.662	66.578	6.024	1.00	52.52	A1	ATOM	334	ND1	HIS	44	23.358	59.689	-2.713	1.00	52.28	A1
ATOM	299	N	LYS	41	23.941	64.600	6.965	1.00	50.54	A1	ATOM	335	HDI	HIS	44	24.130	59.394	-3.251	1.00	0.00	A1
ATOM	300	H	LYS	41	24.474	64.064	7.583	1.00	0.00	A1	ATOM	336	CE1	HIS	44	22.652	58.873	-1.955	1.00	51.92	A1
ATOM	301	CA	LYS	41	23.112	63.885	6.029	1.00	50.48	A1	ATOM	337	NE2	HIS	44	21.947	59.565	-1.091	1.00	50.53	A1
ATOM	302	CB	LYS	41	21.641	63.989	6.540	1.00	50.62	A1	ATOM	338	HE2	HIS	44	21.290	59.189	-0.466	1.00	0.00	A1
ATOM	303	CG	LYS	41	21.387	63.326	7.911	1.00	52.11	A1	ATOM	339	C	HIS	44	25.522	63.941	-3.047	1.00	43.69	A1
ATOM	304	CD	LYS	41	20.112	63.878	8.574	1.00	55.54	A1	ATOM	340	O	HIS	44	24.765	64.906	-3.108	1.00	43.00	A1
ATOM	305	CE	LYS	41	19.578	63.087	9.820	1.00	58.79	A1	ATOM	341	N	PRO	45	26.710	63.978	-3.667	1.00	43.07	A1
ATOM	306	NZ	LYS	41	18.374	63.648	10.457	1.00	58.31	A1	ATOM	342	CD	PRO	45	27.785	62.995	-3.501	1.00	42.17	A1
ATOM	307	HZ1	LYS	41	17.605	63.688	9.757	1.00	0.00	A1	ATOM	343	CA	PRO	45	27.133	65.024	-4.570	1.00	42.50	A1
ATOM	308	HZ2	LYS	41	18.578	64.607	10.803	1.00	0.00	A1	ATOM	344	CB	PRO	45	28.380	64.466	-5.217	1.00	39.76	A1
ATOM	309	HZ3	LYS	41	18.084	63.043	11.252	1.00	0.00	A1	ATOM	345	CG	PRO	45	28.995	63.680	-4.123	1.00	39.09	A1
ATOM	310	C	LYS	41	23.251	64.318	4.588	1.00	49.92	A1	ATOM	346	C	PRO	45	26.071	65.423	-5.585	1.00	44.49	A1
ATOM	311	O	LYS	41	22.312	64.124	3.793	1.00	51.49	A1	ATOM	347	O	PRO	45	25.876	66.612	-5.801	1.00	45.36	A1
ATOM	312	N	LEU	42	24.432	64.893	4.246	1.00	48.28	A1	ATOM	348	N	GLU	46	25.334	64.501	-6.225	1.00	45.36	A1
ATOM	313	H	LEU	42	25.103	65.050	4.937	1.00	0.00	A1	ATOM	349	H	GLU	46	25.464	63.561	-5.996	1.00	0.00	A1
ATOM	314	CA	LEU	42	24.742	65.286	2.859	1.00	46.61	A1	ATOM	350	CA	GLU	46	24.406	64.806	-7.319	1.00	45.46	A1
ATOM	315	CB	LEU	42	25.565	66.574	2.757	1.00	44.69	A1	ATOM	351	CB	GLU	46	23.952	63.515	-7.997	1.00	50.54	A1
ATOM	316	CG	LEU	42	24.807	67.802	3.218	1.00	42.63	A1	ATOM	352	CG	GLU	46	24.462	63.460	-9.445	1.00	58.48	A1
ATOM	317	CD1	LEU	42	25.718	68.580	4.097	1.00	43.29	A1	ATOM	353	CD	GLU	46	23.637	64.215	-10.502	1.00	64.93	A1
ATOM	318	CD2	LEU	42	24.283	68.590	2.045	1.00	41.26	A1	ATOM	354	OE1	GLU	46	23.642	65.455	-10.516	1.00	68.55	A1
ATOM	319	C	LEU	42	25.580	64.124	2.397	1.00	45.46	A1	ATOM	355	OE2	GLU	46	22.995	63.554	-11.332	1.00	68.31	A1
ATOM	320	O	LEU	42	26.766	64.017	2.711	1.00	46.32	A1	ATOM	356	C	GLU	46	23.181	65.584	-6.937	1.00	42.96	A1
ATOM	321	N	CYS	43	24.882	63.193	1.754	1.00	44.09	A1	ATOM	357	O	GLU	46	22.532	66.223	-7.748	1.00	41.71	A1
ATOM	322	H	CYS	43	23.925	63.353	1.619	1.00	0.00	A1	ATOM	358	N	GLU	47	22.919	65.563	-5.654	1.00	41.96	A1

FIG. 5F

ATOM	359	H	GLU	47	23.507	65.098	-5.028	1.00	0.00	A1	ATOM	395	H	LEU	51	23.489	72.958	-6.189	1.00	0.00	A1
ATOM	360	CA	GLU	47	21.818	66.301	-5.144	1.00	43.21	A1	ATOM	396	CA	LEU	51	24.676	74.656	-5.805	1.00	46.04	A1
ATOM	361	CB	GLU	47	21.294	65.487	-3.963	1.00	43.24	A1	ATOM	397	CB	LEU	51	24.860	74.084	-4.435	1.00	45.53	A1
ATOM	362	CG	GLU	47	21.409	65.925	-2.515	1.00	46.07	A1	ATOM	398	CG	LEU	51	25.741	74.931	-3.535	1.00	47.78	A1
ATOM	363	CD	GLU	47	20.812	64.907	-1.547	1.00	47.86	A1	ATOM	399	CD1	LEU	51	25.148	76.320	-3.322	1.00	47.13	A1
ATOM	364	OE1	GLU	47	19.847	64.225	-1.910	1.00	50.99	A1	ATOM	400	CD2	LEU	51	25.902	74.202	-2.219	1.00	48.33	A1
ATOM	365	OE2	GLU	47	21.313	64.780	-0.427	1.00	49.47	A1	ATOM	401	C	LEU	51	26.064	74.845	-6.436	1.00	46.27	A1
ATOM	366	C	GLU	47	22.295	67.718	-4.809	1.00	44.04	A1	ATOM	402	O	LEU	51	26.551	75.966	-6.612	1.00	47.62	A1
ATOM	367	O	GLU	47	21.532	68.547	-4.292	1.00	44.60	A1	ATOM	403	N	GLY	52	26.702	73.736	-6.809	1.00	44.84	A1
ATOM	368	N	LEU	48	23.567	68.015	-5.121	1.00	43.05	A1	ATOM	404	H	GLY	52	26.306	72.869	-6.578	1.00	0.00	A1
ATOM	369	H	LEU	48	24.140	67.310	-5.465	1.00	0.00	A1	ATOM	405	CA	GLY	52	27.989	73.758	-7.453	1.00	42.91	A1
ATOM	370	CA	LEU	48	24.166	69.318	-4.904	1.00	42.42	A1	ATOM	406	C	GLY	52	27.984	74.533	-8.750	1.00	42.47	A1
ATOM	371	CB	LEU	48	25.223	69.201	-3.858	1.00	40.53	A1	ATOM	407	O	GLY	52	28.853	75.364	-8.983	1.00	42.06	A1
ATOM	372	CG	LEU	48	24.920	68.695	-2.489	1.00	41.87	A1	ATOM	408	N	HIS	53	27.047	74.307	-9.653	1.00	42.02	A1
ATOM	373	CD1	LEU	48	26.277	68.424	-1.892	1.00	41.71	A1	ATOM	409	H	HIS	53	26.366	73.624	-9.471	1.00	0.00	A1
ATOM	374	CD2	LEU	48	24.096	69.670	-1.633	1.00	41.13	A1	ATOM	410	CA	HIS	53	27.009	75.104	-10.861	1.00	42.23	A1
ATOM	375	C	LEU	48	24.792	69.937	-6.166	1.00	42.37	A1	ATOM	411	CB	HIS	53	25.842	74.689	-11.706	1.00	42.21	A1
ATOM	376	O	LEU	48	25.439	70.994	-6.098	1.00	42.37	A1	ATOM	412	CG	HIS	53	26.076	73.399	-12.460	1.00	44.60	A1
ATOM	377	N	VAL	49	24.566	69.366	-7.347	1.00	41.52	A1	ATOM	413	CD2	HIS	53	25.112	72.774	-13.200	1.00	47.49	A1
ATOM	378	H	VAL	49	23.951	68.602	-7.362	1.00	0.00	A1	ATOM	414	ND1	HIS	53	27.180	72.669	-12.578	1.00	46.76	A1
ATOM	379	CA	VAL	49	25.191	69.822	-8.578	1.00	43.34	A1	ATOM	415	HD1	HIS	53	28.039	72.853	-12.139	1.00	0.00	A1
ATOM	380	CB	VAL	49	24.890	68.761	-9.636	1.00	44.29	A1	ATOM	416	CE1	HIS	53	26.954	71.641	-13.346	1.00	46.90	A1
ATOM	381	CG1	VAL	49	23.381	68.709	-9.830	1.00	47.50	A1	ATOM	417	NE2	HIS	53	25.704	71.725	-13.707	1.00	50.22	A1
ATOM	382	CG2	VAL	49	25.540	69.086	-10.975	1.00	45.25	A1	ATOM	418	HE2	HIS	53	25.237	71.033	-14.439	1.00	0.00	A1
ATOM	383	C	VAL	49	24.740	71.214	-9.028	1.00	44.98	A1	ATOM	419	C	HIS	53	26.893	76.585	-10.536	1.00	42.72	A1
ATOM	384	O	VAL	49	25.401	71.901	-9.814	1.00	46.03	A1	ATOM	420	O	HIS	53	27.622	77.399	-11.068	1.00	42.03	A1
ATOM	385	N	LEU	50	23.565	71.602	-8.530	1.00	46.16	A1	ATOM	421	N	SER	54	26.099	76.920	-9.535	1.00	45.08	A1
ATOM	386	H	LEU	50	23.081	70.933	-8.006	1.00	0.00	A1	ATOM	422	H	SER	54	25.673	76.218	-9.001	1.00	0.00	A1
ATOM	387	CA	LEU	50	22.908	72.895	-8.729	1.00	46.03	A1	ATOM	423	CA	SER	54	25.792	78.278	-9.177	1.00	46.92	A1
ATOM	388	CB	LEU	50	21.469	72.769	-8.264	1.00	46.43	A1	ATOM	424	CB	SER	54	24.576	78.181	-8.289	1.00	48.86	A1
ATOM	389	CG	LEU	50	20.443	73.718	-8.760	1.00	44.16	A1	ATOM	425	OG	SER	54	23.521	77.616	-9.112	1.00	53.06	A1
ATOM	390	CD1	LEU	50	20.259	73.558	-10.243	1.00	44.79	A1	ATOM	426	HC	SER	54	23.465	76.677	-8.918	1.00	0.00	A1
ATOM	391	CD2	LEU	50	19.159	73.400	-8.079	1.00	44.66	A1	ATOM	427	C	SER	54	26.939	79.033	-8.549	1.00	47.92	A1
ATOM	392	C	LEU	50	23.632	73.968	-7.917	1.00	45.85	A1	ATOM	428	O	SER	54	27.038	80.264	-8.655	1.00	49.60	A1
ATOM	393	O	LEU	50	23.996	74.989	-8.484	1.00	44.52	A1	ATOM	429	N	LEU	55	27.837	78.273	-7.933	1.00	47.59	A1
ATOM	394	N	LEU	51	23.853	73.764	-6.606	1.00	45.44	A1	ATOM	430	H	LEU	55	27.638	77.322	-7.791	1.00	0.00	A1

FIG. 5G

ATOM	431	CA	LEU	55	29.075	78.810	-7.401	1.00	45.27	A1	ATOM	467	CD1	TRP	59	33.972	70.794	-11.354	1.00	45.17	A1
ATOM	432	CB	LEU	55	29.552	77.913	-6.243	1.00	45.49	A1	ATOM	468	NE1	TRP	59	33.229	70.994	-10.297	1.00	43.17	A1
ATOM	433	CG	LEU	55	28.840	77.992	-4.874	1.00	47.30	A1	ATOM	469	HE1	TRP	59	32.301	71.312	-10.332	1.00	0.00	A1
ATOM	434	CD1	LEU	55	28.876	76.596	-4.299	1.00	49.52	A1	ATOM	470	CZ2	TRP	59	33.598	71.215	-7.916	1.00	45.60	A1
ATOM	435	CD2	LEU	55	29.530	78.921	-3.862	1.00	45.69	A1	ATOM	471	CZ3	TRP	59	35.893	71.028	-7.243	1.00	45.25	A1
ATOM	436	C	LEU	55	30.133	78.889	-8.492	1.00	43.63	A1	ATOM	472	CH2	TRP	59	34.565	71.214	-6.938	1.00	46.43	A1
ATOM	437	O	LEU	55	31.247	79.350	-8.272	1.00	43.24	A1	ATOM	473	C	TRP	59	38.815	71.435	-12.256	1.00	52.84	A1
ATOM	438	N	GLY	56	29.855	78.383	-9.675	1.00	43.55	A1	ATOM	474	O	TRP	59	38.842	71.972	-13.372	1.00	54.96	A1
ATOM	439	H	GLY	56	28.984	77.975	-9.828	1.00	0.00	A1	ATOM	475	N	ALA	60	39.912	70.834	-11.777	1.00	51.97	A1
ATOM	440	CA	GLY	56	30.814	78.390	-10.753	1.00	45.59	A1	ATOM	476	H	ALA	60	39.857	70.269	-10.977	1.00	0.00	A1
ATOM	441	C	GLY	56	32.182	77.811	-10.392	1.00	46.76	A1	ATOM	477	CA	ALA	60	41.108	70.870	-12.609	1.00	52.18	A1
ATOM	442	O	GLY	56	33.171	78.213	-11.015	1.00	47.31	A1	ATOM	478	CB	ALA	60	42.303	70.610	-11.748	1.00	51.75	A1
ATOM	443	N	ILE	57	32.247	76.885	-9.412	1.00	47.49	A1	ATOM	479	C	ALA	60	41.055	69.857	-13.746	1.00	52.16	A1
ATOM	444	H	ILE	57	31.392	76.594	-9.042	1.00	0.00	A1	ATOM	480	O	ALA	60	40.545	68.760	-13.530	1.00	52.17	A1
ATOM	445	CA	ILE	57	33.486	76.249	-8.950	1.00	48.28	A1	ATOM	481	N	PRO	61	41.435	70.145	-14.986	1.00	53.34	A1
ATOM	446	CB	ILE	57	33.144	75.172	-7.863	1.00	47.79	A1	ATOM	482	CD	PRO	61	41.370	71.458	-15.622	1.00	54.76	A1
ATOM	447	CG2	ILE	57	34.457	74.591	-7.348	1.00	46.85	A1	ATOM	483	CA	PRO	61	41.691	69.145	-15.993	1.00	55.57	A1
ATOM	448	CG1	ILE	57	32.338	75.764	-6.701	1.00	45.09	A1	ATOM	484	CB	PRO	61	41.792	69.918	-17.310	1.00	54.95	A1
ATOM	449	CD	ILE	57	31.859	74.739	-5.659	1.00	41.23	A1	ATOM	485	CG	PRO	61	42.211	71.297	-16.901	1.00	54.05	A1
ATOM	450	C	ILE	57	34.276	75.602	-10.115	1.00	49.15	A1	ATOM	486	C	PRO	61	42.934	68.333	-15.690	1.00	57.54	A1
ATOM	451	O	ILE	57	33.678	74.935	-10.968	1.00	49.04	A1	ATOM	487	O	PRO	61	43.757	68.661	-14.834	1.00	57.20	A1
ATOM	452	N	PRO	58	35.596	75.817	-10.248	1.00	49.75	A1	ATOM	488	N	LEU	62	43.040	67.271	-16.486	1.00	59.98	A1
ATOM	453	CD	PRO	58	36.402	76.743	-9.433	1.00	50.94	A1	ATOM	489	H	LEU	62	42.285	67.067	-17.077	1.00	0.00	A1
ATOM	454	CA	PRO	58	36.421	75.228	-11.302	1.00	50.72	A1	ATOM	490	CA	LEU	62	44.184	66.370	-16.471	1.00	63.64	A1
ATOM	455	CB	PRO	58	37.525	76.241	-11.488	1.00	50.92	A1	ATOM	491	CB	LEU	62	44.062	65.417	-15.260	1.00	63.72	A1
ATOM	456	CG	PRO	58	37.814	76.663	-10.041	1.00	50.82	A1	ATOM	492	CG	LEU	62	45.323	64.691	-14.865	1.00	64.43	A1
ATOM	457	C	PRO	58	36.916	73.845	-10.875	1.00	50.36	A1	ATOM	493	CD1	LEU	62	46.394	65.704	-14.488	1.00	64.02	A1
ATOM	458	O	PRO	58	37.187	73.599	-9.691	1.00	49.75	A1	ATOM	494	CD2	LEU	62	45.016	63.764	-13.717	1.00	64.98	A1
ATOM	459	N	TRP	59	37.030	72.927	-11.816	1.00	50.37	A1	ATOM	495	C	LEU	62	44.214	65.611	-17.812	1.00	65.69	A1
ATOM	460	H	TRP	59	36.888	73.141	-12.760	1.00	51.78	A1	ATOM	496	OT1	LEU	62	44.256	66.302	-18.844	1.00	68.47	A1
ATOM	461	CA	TRP	59	37.524	71.595	-11.482	1.00	51.78	A1	ATOM	497	OT2	LEU	62	44.194	64.371	-17.845	1.00	66.57	A1
ATOM	462	CB	TRP	59	36.435	70.562	-11.857	1.00	49.06	A1	ATOM	498	CB	LEU	72	57.448	63.159	-19.422	1.00	63.44	A2
ATOM	463	CG	TRP	59	35.254	70.712	-10.889	1.00	46.37	A1	ATOM	499	CG	LEU	72	57.716	62.495	-18.117	1.00	63.40	A2
ATOM	464	CD2	TRP	59	35.320	70.845	-9.521	1.00	44.06	A1	ATOM	500	CD1	LEU	72	56.719	61.408	-17.913	1.00	61.50	A2
ATOM	465	CE2	TRP	59	33.998	71.027	-9.205	1.00	44.18	A1	ATOM	501	CD2	LEU	72	59.107	61.901	-18.121	1.00	63.22	A2
ATOM	466	CE3	TRP	59	36.274	70.842	-8.538	1.00	44.03	A1	ATOM	502	C	LEU	72	55.897	65.084	-18.876	1.00	65.40	A2

FIG. 5H

ATOM	503	O	LEU	72	54.827	65.301	-18.316	1.00	67.30	A2	ATOM	539	CB	SER	77	53.425	70.835	-16.040	1.00	58.32	A2
ATOM	504	HT1	LEU	72	56.469	64.683	-21.261	1.00	0.00	A2	ATOM	540	OG	SER	77	54.806	70.587	-16.310	1.00	63.35	A2
ATOM	505	HT2	LEU	72	54.827	64.355	-20.951	1.00	0.00	A2	ATOM	541	HG	SER	77	54.949	69.637	-16.315	1.00	0.00	A2
ATOM	506	N	LEU	72	55.795	63.983	-20.899	1.00	66.29	A2	ATOM	542	C	SER	77	51.382	70.172	-14.759	1.00	53.47	A2
ATOM	507	HT3	LEU	72	55.866	63.098	-21.439	1.00	0.00	A2	ATOM	543	O	SER	77	50.982	70.965	-13.899	1.00	53.54	A2
ATOM	508	CA	LEU	72	56.064	63.714	-19.512	1.00	64.91	A2	ATOM	544	N	GLN	78	50.509	69.501	-15.512	1.00	51.82	A2
ATOM	509	N	ALA	73	56.807	66.046	-19.086	1.00	64.54	A2	ATOM	545	H	GLN	78	50.857	68.901	-16.207	1.00	0.00	A2
ATOM	510	H	ALA	73	57.690	65.804	-19.432	1.00	0.00	A2	ATOM	546	CA	GLN	78	49.074	69.619	-15.349	1.00	50.74	A2
ATOM	511	CA	ALA	73	56.707	67.433	-18.615	1.00	62.55	A2	ATOM	547	CB	GLN	78	48.402	68.877	-16.451	1.00	54.31	A2
ATOM	512	CB	ALA	73	57.553	68.314	-19.529	1.00	64.84	A2	ATOM	548	CG	GLN	78	47.420	69.784	-17.160	1.00	58.59	A2
ATOM	513	C	ALA	73	55.319	68.024	-18.539	1.00	60.37	A2	ATOM	549	CD	GLN	78	46.557	68.940	-18.071	1.00	62.32	A2
ATOM	514	O	ALA	73	54.801	68.180	-17.456	1.00	59.42	A2	ATOM	550	OE1	GLN	78	47.005	68.260	-18.998	1.00	65.94	A2
ATOM	515	N	GLY	74	54.693	68.226	-19.691	1.00	59.72	A2	ATOM	551	NE2	GLN	78	45.269	68.889	-17.800	1.00	63.17	A2
ATOM	516	H	GLY	74	55.212	68.174	-20.514	1.00	0.00	A2	ATOM	552	HE21	GLN	78	44.973	69.327	-16.972	1.00	0.00	A2
ATOM	517	CA	GLY	74	53.336	68.728	-19.816	1.00	59.99	A2	ATOM	553	HE22	GLN	78	44.704	68.444	-18.456	1.00	0.00	A2
ATOM	518	C	GLY	74	52.327	68.114	-18.865	1.00	60.27	A2	ATOM	554	C	GLN	78	48.591	69.065	-14.011	1.00	48.17	A2
ATOM	519	O	GLY	74	51.880	68.796	-17.935	1.00	60.80	A2	ATOM	555	O	GLN	78	47.691	69.618	-13.368	1.00	46.31	A2
ATOM	520	N	CYS	75	51.945	66.850	-19.030	1.00	59.60	A2	ATOM	556	N	LEU	79	49.236	67.988	-13.564	1.00	45.89	A2
ATOM	521	H	CYS	75	52.160	66.358	-19.839	1.00	0.00	A2	ATOM	557	H	LEU	79	49.920	67.584	-14.140	1.00	0.00	A2
ATOM	522	CA	CYS	75	51.002	66.276	-18.078	1.00	60.17	A2	ATOM	558	CA	LEU	79	48.919	67.359	-12.294	1.00	44.54	A2
ATOM	523	CB	CYS	75	50.670	64.801	-18.464	1.00	64.08	A2	ATOM	559	CB	LEU	79	49.617	66.015	-12.259	1.00	45.06	A2
ATOM	524	SG	CYS	75	49.832	64.732	-20.096	1.00	73.47	A2	ATOM	560	CG	LEU	79	49.154	64.895	-11.351	1.00	45.18	A2
ATOM	525	C	CYS	75	51.502	66.346	-16.642	1.00	56.73	A2	ATOM	561	CD1	LEU	79	49.634	63.594	-11.957	1.00	48.06	A2
ATOM	526	O	CYS	75	50.734	66.748	-15.765	1.00	55.82	A2	ATOM	562	CD2	LEU	79	49.766	64.986	-9.969	1.00	46.03	A2
ATOM	527	N	LEU	76	52.795	66.142	-16.396	1.00	53.93	A2	ATOM	563	C	LEU	79	49.366	68.265	-11.170	1.00	43.49	A2
ATOM	528	H	LEU	76	53.423	66.043	-17.137	1.00	0.00	A2	ATOM	564	O	LEU	79	48.645	68.509	-10.199	1.00	43.20	A2
ATOM	529	CA	LEU	76	53.325	66.156	-15.044	1.00	52.94	A2	ATOM	565	N	HIS	80	50.556	68.834	-11.329	1.00	43.83	A2
ATOM	530	CB	LEU	76	54.798	65.754	-15.181	1.00	50.81	A2	ATOM	566	H	HIS	80	51.115	68.548	-12.085	1.00	0.00	A2
ATOM	531	CG	LEU	76	55.575	65.011	-14.090	1.00	49.02	A2	ATOM	567	CA	HIS	80	51.060	69.788	-10.360	1.00	43.79	A2
ATOM	532	CD1	LEU	76	54.852	63.740	-13.698	1.00	46.76	A2	ATOM	568	CB	HIS	80	52.456	70.221	-10.810	1.00	43.58	A2
ATOM	533	CD2	LEU	76	56.951	64.633	-14.623	1.00	47.67	A2	ATOM	569	CG	HIS	80	53.030	71.031	-9.690	1.00	43.75	A2
ATOM	534	C	LEU	76	53.093	67.545	-14.425	1.00	53.65	A2	ATOM	570	CD2	HIS	80	53.484	70.497	-8.517	1.00	47.48	A2
ATOM	535	O	LEU	76	52.731	67.716	-13.244	1.00	53.50	A2	ATOM	571	ND1	HIS	80	53.083	72.343	-9.567	1.00	44.24	A2
ATOM	536	N	SER	77	53.137	68.553	-15.301	1.00	53.91	A2	ATOM	572	HD1	HIS	80	52.842	73.004	-10.255	1.00	0.00	A2
ATOM	537	H	SER	77	53.322	68.361	-16.242	1.00	0.00	A2	ATOM	573	CE1	HIS	80	53.530	72.641	-8.376	1.00	44.47	A2
ATOM	538	CA	SER	77	52.882	69.932	-14.942	1.00	54.93	A2	ATOM	574	NE2	HIS	80	53.772	71.520	-7.748	1.00	48.16	A2

FIG. 51

ATOM	575	HE2	HIS	80	54.103	71.444	-6.824	1.00	0.00	A2	ATOM	611	O	PHE	84	45.609	74.749	-5.558	1.00	42.71	A2
ATOM	576	C	HIS	80	50.094	70.978	-10.229	1.00	44.40	A2	ATOM	612	N	LEU	85	45.190	73.953	-7.624	1.00	38.64	A2
ATOM	577	O	HIS	80	49.643	71.294	-9.131	1.00	44.28	A2	ATOM	613	H	LEU	85	45.555	73.527	-8.429	1.00	0.00	A2
ATOM	578	N	SER	81	49.733	71.670	-11.309	1.00	45.13	A2	ATOM	614	CA	LEU	85	43.794	74.335	-7.584	1.00	38.81	A2
ATOM	579	H	SER	81	50.136	71.459	-12.176	1.00	0.00	A2	ATOM	615	CB	LEU	85	43.101	73.886	-8.839	1.00	41.27	A2
ATOM	580	CA	SER	81	48.738	72.742	-11.296	1.00	45.41	A2	ATOM	616	CG	LEU	85	41.673	74.403	-9.017	1.00	46.45	A2
ATOM	581	CB	SER	81	48.612	73.347	-12.682	1.00	45.59	A2	ATOM	617	CD1	LEU	85	41.702	75.784	-9.719	1.00	47.80	A2
ATOM	582	OG	SER	81	49.894	73.444	-13.292	1.00	49.27	A2	ATOM	618	CD2	LEU	85	40.860	73.359	-9.787	1.00	48.25	A2
ATOM	583	HG	SER	81	50.058	72.670	-13.843	1.00	0.00	A2	ATOM	619	C	LEU	85	43.079	73.731	-6.386	1.00	38.20	A2
ATOM	584	C	SER	81	47.344	72.266	-10.856	1.00	44.85	A2	ATOM	620	O	LEU	85	42.498	74.469	-5.582	1.00	38.36	A2
ATOM	585	O	SER	81	46.604	73.064	-10.256	1.00	46.83	A2	ATOM	621	N	TYR	86	43.150	72.405	-6.198	1.00	37.92	A2
ATOM	586	N	GLY	82	46.946	71.010	-11.092	1.00	42.16	A2	ATOM	622	H	TYR	86	43.637	71.850	-6.845	1.00	0.00	A2
ATOM	587	H	GLY	82	47.513	70.411	-11.614	1.00	0.00	A2	ATOM	623	CA	TYR	86	42.501	71.801	-5.057	1.00	37.15	A2
ATOM	588	CA	GLY	82	45.663	70.500	-10.650	1.00	39.39	A2	ATOM	624	CB	TYR	86	42.598	70.255	-5.102	1.00	36.73	A2
ATOM	589	C	GLY	82	45.569	70.461	-9.139	1.00	39.30	A2	ATOM	625	CG	TYR	86	41.561	69.685	-6.081	1.00	33.66	A2
ATOM	590	O	GLY	82	44.542	70.843	-8.544	1.00	39.64	A2	ATOM	626	CD1	TYR	86	41.946	69.312	-7.374	1.00	30.03	A2
ATOM	591	N	LEU	83	46.676	70.032	-8.521	1.00	37.57	A2	ATOM	627	CE1	TYR	86	40.991	68.885	-8.280	1.00	30.08	A2
ATOM	592	H	LEU	83	47.413	69.695	-9.075	1.00	0.00	A2	ATOM	628	CD2	TYR	86	40.224	69.623	-5.666	1.00	32.61	A2
ATOM	593	CA	LEU	83	46.826	70.007	-7.057	1.00	38.07	A2	ATOM	629	CE2	TYR	86	39.263	69.203	-6.574	1.00	31.66	A2
ATOM	594	CB	LEU	83	48.133	69.202	-6.748	1.00	35.67	A2	ATOM	630	CZ	TYR	86	39.656	68.838	-7.868	1.00	30.57	A2
ATOM	595	CG	LEU	83	48.071	67.736	-7.225	1.00	32.51	A2	ATOM	631	OH	TYR	86	38.670	68.428	-8.751	1.00	28.18	A2
ATOM	596	CD1	LEU	83	49.442	67.145	-7.319	1.00	29.77	A2	ATOM	632	HH	TYR	86	39.107	67.994	-9.485	1.00	0.00	A2
ATOM	597	CD2	LEU	83	47.180	66.973	-6.288	1.00	28.71	A2	ATOM	633	C	TYR	86	43.054	72.318	-3.746	1.00	37.75	A2
ATOM	598	C	LEU	83	46.836	71.386	-6.354	1.00	38.48	A2	ATOM	634	O	TYR	86	42.173	72.469	-2.889	1.00	39.52	A2
ATOM	599	O	LEU	83	46.392	71.627	-5.219	1.00	38.05	A2	ATOM	635	N	GLN	87	44.347	72.655	-3.478	1.00	36.93	A2
ATOM	600	N	PHE	84	47.366	72.338	-7.108	1.00	40.34	A2	ATOM	636	H	GLN	87	45.044	72.463	-4.140	1.00	0.00	A2
ATOM	601	H	PHE	84	47.804	72.078	-7.944	1.00	0.00	A2	ATOM	637	CA	GLN	87	44.749	73.332	-2.205	1.00	36.40	A2
ATOM	602	CA	PHE	84	47.414	73.703	-6.688	1.00	41.54	A2	ATOM	638	CB	GLN	87	46.210	73.668	-2.255	1.00	39.56	A2
ATOM	603	CB	PHE	84	48.163	74.531	-7.693	1.00	46.88	A2	ATOM	639	CG	GLN	87	47.126	72.993	-1.237	1.00	46.99	A2
ATOM	604	CG	PHE	84	48.715	75.777	-6.988	1.00	55.09	A2	ATOM	640	CD	GLN	87	48.641	73.062	-1.576	1.00	50.96	A2
ATOM	605	CD1	PHE	84	49.521	75.622	-5.849	1.00	55.31	A2	ATOM	641	OE1	GLN	87	49.144	72.623	-2.627	1.00	52.15	A2
ATOM	606	CD2	PHE	84	48.396	77.053	-7.469	1.00	55.79	A2	ATOM	642	NE2	GLN	87	49.446	73.608	-0.663	1.00	52.96	A2
ATOM	607	CE1	PHE	84	50.004	76.737	-5.195	1.00	57.60	A2	ATOM	643	HE21	GLN	87	49.055	73.957	0.164	1.00	0.00	A2
ATOM	608	CE2	PHE	84	48.892	78.156	-6.796	1.00	57.25	A2	ATOM	644	HE22	GLN	87	50.396	73.621	-0.888	1.00	0.00	A2
ATOM	609	CZ	PHE	84	49.688	78.002	-5.667	1.00	58.34	A2	ATOM	645	C	GLN	87	43.941	74.652	-2.013	1.00	34.36	A2
ATOM	610	C	PHE	84	45.994	74.191	-6.591	1.00	40.47	A2	ATOM	646	O	GLN	87	43.414	74.990	-0.935	1.00	31.55	A2

FIG. 5J

ATOM	647	N	GLY	88	43.740	75.335	-3.159	1.00	32.73	A2	ATOM	683	H	ALA	92	39.808	77.205	0.098	1.00	0.00	A2
ATOM	648	H	GLY	88	44.165	75.005	-3.981	1.00	0.00	A2	ATOM	684	CA	ALA	92	38.243	78.402	0.880	1.00	38.10	A2
ATOM	649	CA	GLY	88	42.948	76.546	-3.232	1.00	30.81	A2	ATOM	685	CB	ALA	92	37.657	78.436	-0.511	1.00	36.76	A2
ATOM	650	C	GLY	88	41.540	76.275	-2.731	1.00	30.47	A2	ATOM	686	C	ALA	92	37.139	77.905	1.770	1.00	38.95	A2
ATOM	651	O	GLY	88	41.130	76.819	-1.703	1.00	30.27	A2	ATOM	687	O	ALA	92	36.294	78.687	2.194	1.00	42.45	A2
ATOM	652	N	LEU	89	40.802	75.387	-3.406	1.00	29.01	A2	ATOM	688	N	LEU	93	37.151	76.618	2.123	1.00	38.34	A2
ATOM	653	H	LEU	89	41.220	74.912	-4.154	1.00	0.00	A2	ATOM	689	H	LEU	93	37.855	76.040	1.759	1.00	0.00	A2
ATOM	654	CA	LEU	89	39.447	75.102	-3.009	1.00	27.60	A2	ATOM	690	CA	LEU	93	36.111	76.018	2.972	1.00	36.90	A2
ATOM	655	CB	LEU	89	38.922	74.073	-3.935	1.00	28.13	A2	ATOM	691	CB	LEU	93	36.088	74.463	2.794	1.00	35.34	A2
ATOM	656	CG	LEU	89	38.764	74.583	-5.340	1.00	29.51	A2	ATOM	692	CG	LEU	93	35.725	73.992	1.378	1.00	33.55	A2
ATOM	657	CD1	LEU	89	38.363	73.530	-6.364	1.00	24.13	A2	ATOM	693	CD1	LEU	93	36.159	72.583	1.129	1.00	33.26	A2
ATOM	658	CD2	LEU	89	37.673	75.637	-5.220	1.00	32.87	A2	ATOM	694	CD2	LEU	93	34.254	74.167	1.215	1.00	32.18	A2
ATOM	659	C	LEU	89	39.352	74.629	-1.583	1.00	29.88	A2	ATOM	695	C	LEU	93	36.264	76.353	4.426	1.00	36.44	A2
ATOM	660	O	LEU	89	38.427	75.012	-0.860	1.00	30.81	A2	ATOM	696	O	LEU	93	35.473	75.917	5.256	1.00	35.17	A2
ATOM	661	N	LEU	90	40.317	73.839	-1.094	1.00	32.59	A2	ATOM	697	N	GLU	94	37.357	77.019	4.736	1.00	38.19	A2
ATOM	662	H	LEU	90	41.101	73.626	-1.643	1.00	0.00	A2	ATOM	698	H	GLU	94	38.022	77.167	4.035	1.00	0.00	A2
ATOM	663	CA	LEU	90	40.182	73.274	0.235	1.00	33.41	A2	ATOM	699	CA	GLU	94	37.627	77.573	6.038	1.00	42.71	A2
ATOM	664	CB	LEU	90	41.207	72.234	0.503	1.00	36.15	A2	ATOM	700	CB	GLU	94	36.931	78.947	6.165	1.00	47.38	A2
ATOM	665	CG	LEU	90	41.075	70.971	-0.343	1.00	38.76	A2	ATOM	701	CG	GLU	94	37.418	80.011	5.131	1.00	56.10	A2
ATOM	666	CD1	LEU	90	42.431	70.267	-0.456	1.00	37.21	A2	ATOM	702	CD	GLU	94	36.423	81.153	4.862	1.00	60.26	A2
ATOM	667	CD2	LEU	90	39.995	70.099	0.279	1.00	40.54	A2	ATOM	703	OE1	GLU	94	35.728	81.109	3.823	1.00	60.76	A2
ATOM	668	C	LEU	90	40.342	74.319	1.255	1.00	34.24	A2	ATOM	704	OE2	GLU	94	36.331	82.054	5.721	1.00	61.64	A2
ATOM	669	O	LEU	90	39.711	74.256	2.313	1.00	35.57	A2	ATOM	705	C	GLU	94	37.245	76.701	7.198	1.00	43.90	A2
ATOM	670	N	GLN	91	41.188	75.291	0.940	1.00	35.24	A2	ATOM	706	O	GLU	94	36.624	77.172	8.167	1.00	45.70	A2
ATOM	671	H	GLN	91	41.663	75.284	0.078	1.00	0.00	A2	ATOM	707	N	GLY	95	37.641	75.410	7.001	1.00	44.03	A2
ATOM	672	CA	GLN	91	41.397	76.373	1.883	1.00	37.60	A2	ATOM	708	H	GLY	95	38.024	75.192	6.127	1.00	0.00	A2
ATOM	673	CB	GLN	91	42.557	77.182	1.363	1.00	39.65	A2	ATOM	709	CA	GLY	95	37.519	74.310	7.981	1.00	42.49	A2
ATOM	674	CG	GLN	91	43.155	78.237	2.284	1.00	44.32	A2	ATOM	710	C	GLY	95	36.162	73.612	8.061	1.00	42.24	A2
ATOM	675	CD	GLN	91	44.348	78.799	1.542	1.00	46.96	A2	ATOM	711	O	GLY	95	36.028	72.596	8.739	1.00	40.02	A2
ATOM	676	OE1	GLN	91	45.235	78.083	1.068	1.00	47.42	A2	ATOM	712	N	ILE	96	35.160	74.123	7.328	1.00	42.82	A2
ATOM	677	NE2	GLN	91	44.376	80.092	1.341	1.00	46.82	A2	ATOM	713	H	ILE	96	35.357	74.944	6.841	1.00	0.00	A2
ATOM	678	HE21	GLN	91	43.690	80.685	1.700	1.00	0.00	A2	ATOM	714	CA	ILE	96	33.760	73.692	7.312	1.00	42.12	A2
ATOM	679	HE22	GLN	91	45.108	80.331	0.741	1.00	0.00	A2	ATOM	715	CB	ILE	96	33.665	72.233	6.800	1.00	36.33	A2
ATOM	680	C	GLN	91	40.129	77.231	2.061	1.00	37.22	A2	ATOM	716	CG2	ILE	96	32.248	71.768	6.789	1.00	34.79	A2
ATOM	681	O	GLN	91	39.718	77.530	3.186	1.00	36.21	A2	ATOM	717	CG1	ILE	96	34.091	72.157	5.374	1.00	35.35	A2
ATOM	682	N	ALA	92	39.456	77.570	0.943	1.00	38.63	A2	ATOM	718	CD	ILE	96	34.051	70.743	4.738	1.00	33.64	A2

FIG. 5K

ATOM	719	C	ILE	96	33.106	73.863	8.709	1.00	44.74	A2	ATOM	755	N	GLY	101	37.441	70.505	11.272	1.00	45.40	A2
ATOM	720	O	ILE	96	32.220	74.716	8.841	1.00	44.59	A2	ATOM	756	H	GLY	101	36.893	70.704	12.056	1.00	0.00	A2
ATOM	721	N	SER	97	33.467	73.154	9.780	1.00	46.84	A2	ATOM	757	CA	GLY	101	38.703	71.238	11.126	1.00	42.52	A2
ATOM	722	H	SER	97	34.243	72.553	9.706	1.00	0.00	A2	ATOM	758	C	GLY	101	39.885	70.334	10.798	1.00	40.73	A2
ATOM	723	CA	SER	97	32.900	73.359	11.105	1.00	48.91	A2	ATOM	759	O	GLY	101	40.475	70.402	9.710	1.00	40.69	A2
ATOM	724	CB	SER	97	31.804	72.343	11.347	1.00	49.60	A2	ATOM	760	N	PRO	102	40.250	69.441	11.708	1.00	38.61	A2
ATOM	725	OG	SER	97	32.211	71.120	11.954	1.00	52.85	A2	ATOM	761	CD	PRO	102	39.676	69.350	13.027	1.00	39.26	A2
ATOM	726	HG	SER	97	31.406	70.573	11.942	1.00	0.00	A2	ATOM	762	CA	PRO	102	41.390	68.566	11.606	1.00	37.30	A2
ATOM	727	C	SER	97	34.045	73.143	12.077	1.00	50.64	A2	ATOM	763	CB	PRO	102	41.294	67.690	12.775	1.00	39.36	A2
ATOM	728	O	SER	97	35.035	72.538	11.678	1.00	52.78	A2	ATOM	764	CG	PRO	102	40.799	68.687	13.776	1.00	41.02	A2
ATOM	729	N	PRO	98	34.063	73.474	13.348	1.00	52.12	A2	ATOM	765	C	PRO	102	41.364	67.795	10.331	1.00	37.15	A2
ATOM	730	CD	PRO	98	33.002	74.170	14.016	1.00	52.90	A2	ATOM	766	O	PRO	102	42.358	67.854	9.600	1.00	38.88	A2
ATOM	731	CA	PRO	98	35.195	73.200	14.257	1.00	54.94	A2	ATOM	767	N	THR	103	40.223	67.167	10.045	1.00	35.36	A2
ATOM	732	CB	PRO	98	34.750	73.717	15.600	1.00	54.78	A2	ATOM	768	H	THR	103	39.466	67.223	10.662	1.00	0.00	A2
ATOM	733	CG	PRO	98	33.772	74.777	15.182	1.00	55.48	A2	ATOM	769	CA	THR	103	40.051	66.386	8.843	1.00	34.62	A2
ATOM	734	C	PRO	98	35.591	71.723	14.336	1.00	56.75	A2	ATOM	770	CB	THR	103	38.592	65.888	8.715	1.00	34.07	A2
ATOM	735	O	PRO	98	36.738	71.274	14.468	1.00	57.85	A2	ATOM	771	OG1	THR	103	38.356	65.240	9.936	1.00	35.43	A2
ATOM	736	N	GLU	99	34.509	70.971	14.214	1.00	58.21	A2	ATOM	772	HG1	THR	103	38.011	65.896	10.548	1.00	0.00	A2
ATOM	737	H	GLU	99	33.652	71.400	14.028	1.00	0.00	A2	ATOM	773	CG2	THR	103	38.312	64.896	7.594	1.00	31.29	A2
ATOM	738	CA	GLU	99	34.543	69.537	14.281	1.00	58.48	A2	ATOM	774	C	THR	103	40.417	67.215	7.625	1.00	34.61	A2
ATOM	739	CB	GLU	99	33.111	69.104	14.304	1.00	63.30	A2	ATOM	775	O	THR	103	41.091	66.665	6.738	1.00	38.16	A2
ATOM	740	CG	GLU	99	32.958	67.702	14.852	1.00	71.04	A2	ATOM	776	N	LEU	104	40.054	68.498	7.529	1.00	32.49	A2
ATOM	741	CD	GLU	99	32.076	66.838	13.962	1.00	76.95	A2	ATOM	777	H	LEU	104	39.504	68.923	8.229	1.00	0.00	A2
ATOM	742	OE1	GLU	99	32.209	65.608	14.079	1.00	80.63	A2	ATOM	778	CA	LEU	104	40.471	69.267	6.370	1.00	30.49	A2
ATOM	743	OE2	GLU	99	31.295	67.382	13.153	1.00	77.99	A2	ATOM	779	CB	LEU	104	39.616	70.430	6.242	1.00	33.51	A2
ATOM	744	C	GLU	99	35.298	69.025	13.074	1.00	55.31	A2	ATOM	780	CG	LEU	104	38.356	69.996	5.611	1.00	36.61	A2
ATOM	745	O	GLU	99	36.251	68.270	13.210	1.00	55.96	A2	ATOM	781	CD1	LEU	104	37.222	70.621	6.381	1.00	39.43	A2
ATOM	746	N	LEU	100	34.916	69.475	11.891	1.00	51.23	A2	ATOM	782	CD2	LEU	104	38.418	70.294	4.132	1.00	37.89	A2
ATOM	747	H	LEU	100	34.214	70.159	11.841	1.00	0.00	A2	ATOM	783	C	LEU	104	41.904	69.727	6.414	1.00	28.48	A2
ATOM	748	CA	LEU	100	35.577	69.052	10.678	1.00	48.08	A2	ATOM	784	O	LEU	104	42.583	69.825	5.398	1.00	28.47	A2
ATOM	749	CB	LEU	100	34.627	69.341	9.574	1.00	45.52	A2	ATOM	785	N	ASP	105	42.449	69.949	7.574	1.00	26.99	A2
ATOM	750	CG	LEU	100	33.544	68.337	9.674	1.00	45.39	A2	ATOM	786	H	ASP	105	41.903	69.912	8.388	1.00	0.00	A2
ATOM	751	CD1	LEU	100	32.207	68.972	9.458	1.00	46.40	A2	ATOM	787	CA	ASP	105	43.822	70.307	7.613	1.00	28.67	A2
ATOM	752	CD2	LEU	100	33.851	67.245	8.677	1.00	47.48	A2	ATOM	788	CB	ASP	105	44.139	70.584	9.038	1.00	33.06	A2
ATOM	753	C	LEU	100	36.956	69.629	10.368	1.00	46.77	A2	ATOM	789	CG	ASP	105	43.438	71.808	9.593	1.00	35.46	A2
ATOM	754	O	LEU	100	37.578	69.244	9.357	1.00	46.62	A2	ATOM	790	OD1	ASP	105	43.085	72.726	8.836	1.00	38.42	A2

FIG. 5L

ATOM	791	OD2 ASP	105	43.244	71.816	10.808	1.00	39.10	A2	ATOM	827	CB LEU	109	48.951	68.637	5.513	1.00	29.41	A2
ATOM	792	C ASP	105	44.701	69.206	7.032	1.00	28.90	A2	ATOM	828	CG LEU	109	48.712	69.771	6.520	1.00	31.78	A2
ATOM	793	O ASP	105	45.551	69.479	6.175	1.00	29.62	A2	ATOM	829	CD1 LEU	109	48.750	69.188	7.933	1.00	29.16	A2
ATOM	794	N THR	106	44.415	67.950	7.401	1.00	26.86	A2	ATOM	830	CD2 LEU	109	49.774	70.889	6.285	1.00	32.19	A2
ATOM	795	H THR	106	43.674	67.826	8.029	1.00	0.00	A2	ATOM	831	C LEU	109	49.168	67.790	3.186	1.00	26.80	A2
ATOM	796	CA THR	106	45.143	66.770	6.935	1.00	24.81	A2	ATOM	832	O LEU	109	50.214	67.721	2.544	1.00	26.81	A2
ATOM	797	CB THR	106	44.558	65.456	7.477	1.00	26.03	A2	ATOM	833	N ASP	110	48.305	66.807	3.090	1.00	25.98	A2
ATOM	798	OG1 THR	106	44.680	65.566	8.894	1.00	31.53	A2	ATOM	834	H ASP	110	47.471	66.835	3.600	1.00	0.00	A2
ATOM	799	HG1 THR	106	44.069	66.223	9.242	1.00	0.00	A2	ATOM	835	CA ASP	110	48.590	65.684	2.250	1.00	23.32	A2
ATOM	800	CG2 THR	106	45.258	64.220	7.011	1.00	20.90	A2	ATOM	836	CB ASP	110	47.577	64.570	2.553	1.00	26.34	A2
ATOM	801	C THR	106	45.073	66.684	5.460	1.00	23.75	A2	ATOM	837	CG ASP	110	47.905	63.878	3.894	1.00	31.10	A2
ATOM	802	O THR	106	46.065	66.411	4.812	1.00	24.68	A2	ATOM	838	OD1 ASP	110	47.070	63.093	4.323	1.00	34.98	A2
ATOM	803	N LEU	107	43.887	66.917	4.946	1.00	24.30	A2	ATOM	839	OD2 ASP	110	48.958	64.107	4.535	1.00	34.06	A2
ATOM	804	H LEU	107	43.145	67.176	5.528	1.00	0.00	A2	ATOM	840	C ASP	110	48.557	66.138	0.842	1.00	21.31	A2
ATOM	805	CA LEU	107	43.668	66.783	3.531	1.00	27.29	A2	ATOM	841	O ASP	110	49.493	65.711	0.165	1.00	20.63	A2
ATOM	806	CB LEU	107	42.158	66.913	3.273	1.00	25.45	A2	ATOM	842	N VAL	111	47.627	66.998	0.363	1.00	20.80	A2
ATOM	807	CG LEU	107	41.642	66.888	1.863	1.00	26.24	A2	ATOM	843	H VAL	111	46.900	67.310	0.944	1.00	0.00	A2
ATOM	808	CD1 LEU	107	42.095	65.649	1.158	1.00	26.41	A2	ATOM	844	CA VAL	111	47.711	67.454	-1.019	1.00	20.44	A2
ATOM	809	CD2 LEU	107	40.140	66.925	1.914	1.00	27.62	A2	ATOM	845	CB VAL	111	46.531	68.364	-1.376	1.00	23.60	A2
ATOM	810	C LEU	107	44.485	67.848	2.819	1.00	28.01	A2	ATOM	846	CG1 VAL	111	46.615	68.946	-2.808	1.00	23.04	A2
ATOM	811	O LEU	107	45.154	67.555	1.823	1.00	30.72	A2	ATOM	847	CG2 VAL	111	45.289	67.497	-1.371	1.00	24.30	A2
ATOM	812	N GLN	108	44.540	69.055	3.373	1.00	28.52	A2	ATOM	848	C VAL	111	49.006	68.224	-1.245	1.00	20.82	A2
ATOM	813	H GLN	108	44.030	69.221	4.194	1.00	0.00	A2	ATOM	849	O VAL	111	49.617	68.006	-2.303	1.00	19.22	A2
ATOM	814	CA GLN	108	45.343	70.132	2.792	1.00	28.38	A2	ATOM	850	N ALA	112	49.442	69.063	-0.267	1.00	21.84	A2
ATOM	815	CB GLN	108	45.138	71.363	3.630	1.00	30.15	A2	ATOM	851	H ALA	112	48.839	69.190	0.492	1.00	0.00	A2
ATOM	816	CG GLN	108	43.711	71.787	3.542	1.00	32.67	A2	ATOM	852	CA ALA	112	50.708	69.805	-0.295	1.00	24.16	A2
ATOM	817	CD GLN	108	43.606	73.192	4.048	1.00	35.24	A2	ATOM	853	CB ALA	112	50.861	70.561	1.011	1.00	22.69	A2
ATOM	818	OE1 GLN	108	43.085	73.484	5.125	1.00	36.07	A2	ATOM	854	C ALA	112	51.931	68.878	-0.486	1.00	28.58	A2
ATOM	819	NE2 GLN	108	44.189	74.044	3.213	1.00	33.58	A2	ATOM	855	O ALA	112	52.778	69.026	-1.390	1.00	32.53	A2
ATOM	820	HE21 GLN	108	44.582	73.701	2.386	1.00	0.00	A2	ATOM	856	N ASP	113	52.086	67.852	0.343	1.00	30.21	A2
ATOM	821	HE22 GLN	108	44.195	74.986	3.471	1.00	0.00	A2	ATOM	857	H ASP	113	51.507	67.817	1.130	1.00	0.00	A2
ATOM	822	C GLN	108	46.840	69.842	2.675	1.00	26.40	A2	ATOM	858	CA ASP	113	53.084	66.846	0.166	1.00	31.70	A2
ATOM	823	O GLN	108	47.450	69.955	1.597	1.00	27.57	A2	ATOM	859	CB ASP	113	52.706	65.659	0.953	1.00	36.31	A2
ATOM	824	N LEU	109	47.388	69.473	3.833	1.00	25.81	A2	ATOM	860	CG ASP	113	53.170	65.758	2.357	1.00	42.27	A2
ATOM	825	H LEU	109	46.795	69.495	4.615	1.00	0.00	A2	ATOM	861	OD1 ASP	113	52.559	65.109	3.203	1.00	46.37	A2
ATOM	826	CA LEU	109	48.764	69.003	4.043	1.00	27.96	A2	ATOM	862	OD2 ASP	113	54.160	66.461	2.589	1.00	48.93	A2

FIG. 5M

ATOM	863	C	ASP	113	53.315	66.361	-1.239	1.00	32.82	A2	ATOM	899	C	THR	117	56.882	65.417	-6.134	1.00	43.42	A2
ATOM	864	O	ASP	113	54.433	66.308	-1.754	1.00	36.25	A2	ATOM	900	O	THR	117	57.934	65.253	-6.749	1.00	46.29	A2
ATOM	865	N	PHE	114	52.187	65.978	-1.830	1.00	30.94	A2	ATOM	901	N	ILE	118	55.763	65.777	-6.741	1.00	45.87	A2
ATOM	866	H	PHE	114	51.344	66.164	-1.361	1.00	0.00	A2	ATOM	902	H	ILE	118	54.962	65.942	-6.200	1.00	0.00	A2
ATOM	867	CA	PHE	114	52.109	65.328	-3.103	1.00	27.84	A2	ATOM	903	CA	ILE	118	55.659	65.914	-8.182	1.00	47.97	A2
ATOM	868	CB	PHE	114	50.708	64.794	-3.226	1.00	23.18	A2	ATOM	904	CB	ILE	118	54.170	66.271	-8.452	1.00	47.69	A2
ATOM	869	CG	PHE	114	50.565	63.928	-4.420	1.00	21.04	A2	ATOM	905	CG	ILE	118	54.041	66.930	-9.835	1.00	47.03	A2
ATOM	870	CD	PHE	114	51.623	63.225	-4.938	1.00	24.05	A2	ATOM	906	CG	ILE	118	53.302	65.011	-8.244	1.00	44.00	A2
ATOM	871	CD	PHE	114	49.369	63.914	-5.046	1.00	22.37	A2	ATOM	907	CD	ILE	118	53.651	63.883	-9.236	1.00	43.71	A2
ATOM	872	CE	PHE	114	51.476	62.514	-6.102	1.00	24.54	A2	ATOM	908	C	ILE	118	56.647	66.932	-8.724	1.00	50.69	A2
ATOM	873	CE	PHE	114	49.211	63.207	-6.212	1.00	21.33	A2	ATOM	909	O	ILE	118	57.390	66.676	-9.681	1.00	49.98	A2
ATOM	874	CZ	PHE	114	50.263	62.509	-6.741	1.00	24.71	A2	ATOM	910	N	TRP	119	56.697	68.061	-8.015	1.00	54.68	A2
ATOM	875	C	PHE	114	52.453	66.291	-4.190	1.00	29.20	A2	ATOM	911	H	TRP	119	56.164	68.135	-7.197	1.00	0.00	A2
ATOM	876	O	PHE	114	53.072	65.883	-5.158	1.00	30.84	A2	ATOM	912	CA	TRP	119	57.575	69.142	-8.399	1.00	58.98	A2
ATOM	877	N	ALA	115	52.057	67.554	-4.058	1.00	31.99	A2	ATOM	913	CB	TRP	119	57.392	70.367	-7.477	1.00	59.84	A2
ATOM	878	H	ALA	115	51.446	67.768	-3.317	1.00	0.00	A2	ATOM	914	CG	TRP	119	58.051	71.529	-8.196	1.00	62.64	A2
ATOM	879	CA	ALA	115	52.423	68.655	-4.952	1.00	31.29	A2	ATOM	915	CD	TRP	119	57.596	72.211	-9.307	1.00	63.78	A2
ATOM	880	CB	ALA	115	51.824	69.939	-4.420	1.00	30.65	A2	ATOM	916	CE	TRP	119	58.699	72.955	-9.643	1.00	62.55	A2
ATOM	881	C	ALA	115	53.936	68.787	-4.976	1.00	31.31	A2	ATOM	917	CE	TRP	119	56.465	72.314	-10.080	1.00	66.02	A2
ATOM	882	O	ALA	115	54.539	68.823	-6.044	1.00	30.36	A2	ATOM	918	CD	TRP	119	59.322	71.870	-7.863	1.00	64.12	A2
ATOM	883	N	THR	116	54.551	68.846	-3.813	1.00	32.20	A2	ATOM	919	NE	TRP	119	59.680	72.727	-8.784	1.00	65.00	A2
ATOM	884	H	THR	116	54.013	68.910	-2.992	1.00	0.00	A2	ATOM	920	HE	TRP	119	60.568	73.140	-8.828	1.00	0.00	A2
ATOM	885	CA	THR	116	55.998	68.897	-3.656	1.00	34.91	A2	ATOM	921	CZ	TRP	119	58.726	73.794	-10.714	1.00	62.90	A2
ATOM	886	CB	THR	116	56.325	68.953	-2.150	1.00	35.78	A2	ATOM	922	CZ	TRP	119	56.469	73.157	-11.170	1.00	65.18	A2
ATOM	887	OG	THR	116	55.564	70.038	-1.576	1.00	35.58	A2	ATOM	923	CH	TRP	119	57.591	73.887	-11.481	1.00	64.40	A2
ATOM	888	HG	THR	116	54.942	69.644	-0.939	1.00	0.00	A2	ATOM	924	C	TRP	119	59.021	68.664	-8.352	1.00	61.26	A2
ATOM	889	CG	THR	116	57.816	69.050	-1.921	1.00	35.38	A2	ATOM	925	O	TRP	119	59.748	68.788	-9.343	1.00	62.12	A2
ATOM	890	C	THR	116	56.714	67.726	-4.304	1.00	37.14	A2	ATOM	926	N	GLN	120	59.447	68.065	-7.249	1.00	62.91	A2
ATOM	891	O	THR	116	57.641	67.937	-5.066	1.00	39.27	A2	ATOM	927	H	GLN	120	58.811	67.961	-6.519	1.00	0.00	A2
ATOM	892	N	THR	117	56.318	66.485	-4.045	1.00	39.05	A2	ATOM	928	CA	GLN	120	60.786	67.504	-7.113	1.00	65.16	A2
ATOM	893	H	THR	117	55.615	66.383	-3.369	1.00	0.00	A2	ATOM	929	CB	GLN	120	60.900	66.800	-5.780	1.00	66.56	A2
ATOM	894	CA	THR	117	56.840	65.269	-4.630	1.00	40.23	A2	ATOM	930	CG	GLN	120	60.627	67.678	-4.582	1.00	67.18	A2
ATOM	895	CB	THR	117	55.909	64.090	-4.216	1.00	39.99	A2	ATOM	931	CD	GLN	120	60.725	66.907	-3.284	1.00	67.77	A2
ATOM	896	OG	THR	117	56.149	63.920	-2.820	1.00	41.66	A2	ATOM	932	OE	GLN	120	61.221	67.465	-2.319	1.00	69.31	A2
ATOM	897	HG	THR	117	55.653	64.559	-2.286	1.00	0.00	A2	ATOM	933	NE	GLN	120	60.305	65.654	-3.129	1.00	67.39	A2
ATOM	898	CG	THR	117	56.110	62.781	-4.981	1.00	38.23	A2	ATOM	934	HE	GLN	120	59.903	65.174	-3.877	1.00	0.00	A2

FIG. 5N

ATOM	935	HE22	GLN	120	60.441	65.282	-2.234	1.00	0.00	ATOM	971	CA	GLU	124	65.574	66.215	-11.167	1.00	78.47	A2
ATOM	936	C	GLN	120	61.169	66.509	-8.222	1.00	66.22	ATOM	972	CB	GLU	124	65.600	65.051	-10.195	1.00	80.79	A2
ATOM	937	O	GLN	120	62.326	66.421	-8.662	1.00	66.50	ATOM	973	CG	GLU	124	64.387	64.132	-10.150	1.00	83.29	A2
ATOM	938	N	GLN	121	60.202	65.745	-8.706	1.00	67.10	ATOM	974	CD	GLU	124	64.375	63.248	-8.908	1.00	85.51	A2
ATOM	939	H	GLN	121	59.307	65.754	-8.303	1.00	0.00	ATOM	975	OE1	GLU	124	64.733	63.729	-7.824	1.00	86.84	A2
ATOM	940	CA	GLN	121	60.480	64.878	-9.812	1.00	68.66	ATOM	976	OE2	GLU	124	64.006	62.075	-9.024	1.00	86.39	A2
ATOM	941	CB	GLN	121	59.292	63.971	-10.070	1.00	67.96	ATOM	977	C	GLU	124	65.534	65.705	-12.612	1.00	78.01	A2
ATOM	942	CG	GLN	121	59.614	62.937	-11.128	1.00	68.89	ATOM	978	O	GLU	124	66.480	65.057	-13.060	1.00	78.91	A2
ATOM	943	CD	GLN	121	60.940	62.236	-10.852	1.00	71.37	ATOM	979	N	LEU	125	64.460	65.943	-13.363	1.00	77.11	A2
ATOM	944	OE1	GLN	121	61.212	61.706	-9.777	1.00	71.70	ATOM	980	H	LEU	125	63.666	66.340	-12.945	1.00	0.00	A2
ATOM	945	NE2	GLN	121	61.879	62.262	-11.786	1.00	74.41	ATOM	981	CA	LEU	125	64.387	65.583	-14.771	1.00	76.23	A2
ATOM	946	HE21	GLN	121	61.707	62.729	-12.627	1.00	0.00	ATOM	982	CB	LEU	125	63.061	64.832	-14.952	1.00	76.88	A2
ATOM	947	HE22	GLN	121	62.736	61.859	-11.541	1.00	0.00	ATOM	983	CG	LEU	125	62.392	64.382	-16.263	1.00	76.63	A2
ATOM	948	C	GLN	121	60.760	65.743	-11.045	1.00	70.48	ATOM	984	CD1	LEU	125	63.350	63.754	-17.276	1.00	76.67	A2
ATOM	949	O	GLN	121	61.671	65.436	-11.827	1.00	70.94	ATOM	985	CD2	LEU	125	61.309	63.402	-15.839	1.00	75.89	A2
ATOM	950	N	MET	122	60.019	66.846	-11.236	1.00	71.67	ATOM	986	C	LEU	125	64.506	66.827	-15.648	1.00	75.84	A2
ATOM	951	H	MET	122	59.351	67.087	-10.555	1.00	0.00	ATOM	987	O	LEU	125	64.360	66.788	-16.871	1.00	75.36	A2
ATOM	952	CA	MET	122	60.190	67.688	-12.412	1.00	72.62	ATOM	988	N	GLY	126	64.759	67.968	-15.027	1.00	75.90	A2
ATOM	953	CB	MET	122	59.173	68.819	-12.448	1.00	73.12	ATOM	989	H	GLY	126	64.741	67.976	-14.056	1.00	0.00	A2
ATOM	954	CG	MET	122	57.880	68.343	-13.083	1.00	73.64	ATOM	990	CA	GLY	126	64.968	69.213	-15.736	1.00	77.58	A2
ATOM	955	SD	MET	122	56.669	69.662	-13.295	1.00	75.44	ATOM	991	C	GLY	126	63.697	69.814	-16.330	1.00	78.63	A2
ATOM	956	CE	MET	122	55.695	69.349	-11.861	1.00	76.43	ATOM	992	O	GLY	126	63.735	70.736	-17.146	1.00	78.55	A2
ATOM	957	C	MET	122	61.566	68.281	-12.411	1.00	73.22	ATOM	993	N	MET	127	62.524	69.343	-15.933	1.00	80.08	A2
ATOM	958	O	MET	122	62.240	68.287	-13.441	1.00	73.03	ATOM	994	H	MET	127	62.522	68.603	-15.293	1.00	0.00	A2
ATOM	959	N	GLU	123	61.372	68.697	-11.223	1.00	74.74	ATOM	995	CA	MET	127	61.266	69.902	-16.415	1.00	81.46	A2
ATOM	960	H	GLU	123	61.372	68.617	-10.466	1.00	0.00	ATOM	996	CB	MET	127	60.191	68.802	-16.361	1.00	81.86	A2
ATOM	961	CA	GLU	123	63.305	69.262	-11.018	1.00	75.95	ATOM	997	CG	MET	127	60.708	67.599	-17.147	1.00	82.66	A2
ATOM	962	CB	GLU	123	63.484	69.665	-9.597	1.00	75.72	ATOM	998	SD	MET	127	59.682	66.115	-17.282	1.00	83.70	A2
ATOM	963	CG	GLU	123	62.644	70.906	-9.500	1.00	79.11	ATOM	999	CE	MET	127	60.236	65.620	-18.900	1.00	83.23	A2
ATOM	964	CD	GLU	123	62.651	71.529	-8.122	1.00	83.02	ATOM	1000	C	MET	127	60.847	71.131	-15.599	1.00	82.18	A2
ATOM	965	OE1	GLU	123	62.741	72.763	-8.057	1.00	84.15	ATOM	1001	OT1	MET	127	60.116	71.958	-16.142	1.00	83.86	A2
ATOM	966	OE2	GLU	123	62.543	70.789	-7.133	1.00	84.45	ATOM	1002	OT2	MET	127	61.267	71.285	-14.446	1.00	82.04	A2
ATOM	967	C	GLU	123	64.381	68.280	-11.386	1.00	77.17	ATOM	1003	CB	MET	138	39.323	80.595	-4.492	1.00	59.39	A3
ATOM	968	O	GLU	123	65.092	68.558	-12.356	1.00	78.22	ATOM	1004	CG	MET	138	40.123	79.298	-4.421	1.00	57.97	A3
ATOM	969	N	GLU	124	64.504	67.110	-10.765	1.00	77.66	ATOM	1005	SD	MET	138	40.561	78.973	-6.145	1.00	60.85	A3
ATOM	970	H	GLU	124	63.867	66.852	-10.060	1.00	0.00	ATOM	1006	CE	MET	138	41.129	77.310	-6.351	1.00	61.48	A3

FIG. 50

ATOM 1007	C MET 138	37.021	81.072	-5.454	1.00	60.26	A3	ATOM 1043	C ALA 142	28.703	82.132	2.802	1.00	45.27	A3
ATOM 1008	O MET 138	36.832	82.262	-5.181	1.00	62.98	A3	ATOM 1044	O ALA 142	28.343	83.002	3.584	1.00	47.38	A3
ATOM 1009	HT1 MET 138	38.497	82.600	-6.075	1.00	0.00	A3	ATOM 1045	N SER 143	28.318	80.860	2.899	1.00	43.36	A3
ATOM 1010	HT2 MET 138	38.313	81.757	-7.529	1.00	0.00	A3	ATOM 1046	H SER 143	28.724	80.201	2.303	1.00	0.00	A3
ATOM 1011	N MET 138	38.839	81.784	-6.639	1.00	60.49	A3	ATOM 1047	CA SER 143	27.377	80.392	3.897	1.00	41.94	A3
ATOM 1012	HT3 MET 138	39.865	81.816	-6.768	1.00	0.00	A3	ATOM 1048	CB SER 143	26.036	80.129	3.181	1.00	44.17	A3
ATOM 1013	CA MET 138	38.445	80.672	-5.787	1.00	60.51	A3	ATOM 1049	OG SER 143	25.323	78.918	3.536	1.00	48.18	A3
ATOM 1014	N PRO 139	35.995	80.242	-5.612	1.00	57.82	A3	ATOM 1050	HG SER 143	24.455	78.974	3.098	1.00	0.00	A3
ATOM 1015	CD PRO 139	36.028	79.060	-6.448	1.00	58.10	A3	ATOM 1051	C SER 143	27.877	79.145	4.602	1.00	39.79	A3
ATOM 1016	CA PRO 139	34.654	80.538	-5.142	1.00	54.67	A3	ATOM 1052	O SER 143	28.763	78.452	4.132	1.00	38.50	A3
ATOM 1017	CB PRO 139	33.870	79.323	-5.525	1.00	54.54	A3	ATOM 1053	N ALA 144	27.218	78.775	5.683	1.00	39.10	A3
ATOM 1018	CG PRO 139	34.945	78.290	-5.755	1.00	58.20	A3	ATOM 1054	H ALA 144	26.449	79.312	5.960	1.00	0.00	A3
ATOM 1019	C PRO 139	34.588	80.875	-3.664	1.00	52.24	A3	ATOM 1055	CA ALA 144	27.566	77.586	6.411	1.00	39.22	A3
ATOM 1020	O PRO 139	35.507	80.623	-2.882	1.00	51.89	A3	ATOM 1056	CB ALA 144	26.982	77.598	7.802	1.00	36.97	A3
ATOM 1021	N ALA 140	33.499	81.547	-3.342	1.00	49.86	A3	ATOM 1057	C ALA 144	26.964	76.420	5.627	1.00	41.58	A3
ATOM 1022	H ALA 140	32.789	81.676	-4.005	1.00	0.00	A3	ATOM 1058	O ALA 144	27.706	75.448	5.444	1.00	42.07	A3
ATOM 1023	CA ALA 140	33.234	81.926	-1.994	1.00	49.39	A3	ATOM 1059	N PHE 145	25.719	76.407	5.076	1.00	40.77	A3
ATOM 1024	CB ALA 140	32.966	83.413	-1.895	1.00	49.94	A3	ATOM 1060	H PHE 145	25.149	77.203	5.110	1.00	0.00	A3
ATOM 1025	C ALA 140	31.978	81.153	-1.590	1.00	49.25	A3	ATOM 1061	CA PHE 145	25.307	75.234	4.312	1.00	39.31	A3
ATOM 1026	O ALA 140	30.889	81.162	-2.205	1.00	49.06	A3	ATOM 1062	CB PHE 145	23.877	75.396	3.798	1.00	36.46	A3
ATOM 1027	N PHE 141	32.293	80.442	-0.506	1.00	47.48	A3	ATOM 1063	CG PHE 145	23.477	74.452	2.641	1.00	31.91	A3
ATOM 1028	H PHE 141	33.190	80.550	-0.122	1.00	0.00	A3	ATOM 1064	CD1 PHE 145	23.579	74.900	1.323	1.00	29.02	A3
ATOM 1029	CA PHE 141	31.401	79.552	0.208	1.00	45.66	A3	ATOM 1065	CD2 PHE 145	23.013	73.185	2.916	1.00	29.40	A3
ATOM 1030	CB PHE 141	32.215	78.305	0.792	1.00	40.28	A3	ATOM 1066	CE1 PHE 145	23.225	74.100	0.277	1.00	28.34	A3
ATOM 1031	CG PHE 141	32.684	77.404	-0.349	1.00	35.35	A3	ATOM 1067	CE2 PHE 145	22.661	72.389	1.858	1.00	28.80	A3
ATOM 1032	CD1 PHE 141	31.800	76.591	-1.006	1.00	34.39	A3	ATOM 1068	CZ PHE 145	22.764	72.831	0.549	1.00	30.58	A3
ATOM 1033	CD2 PHE 141	33.966	77.497	-0.830	1.00	37.69	A3	ATOM 1069	C PHE 145	26.266	75.071	3.120	1.00	40.44	A3
ATOM 1034	CE1 PHE 141	32.174	75.895	-2.133	1.00	34.00	A3	ATOM 1070	O PHE 145	26.556	73.938	2.697	1.00	40.55	A3
ATOM 1035	CE2 PHE 141	34.358	76.807	-1.956	1.00	36.69	A3	ATOM 1071	N GLN 146	26.745	76.232	2.619	1.00	39.11	A3
ATOM 1036	CZ PHE 141	33.449	76.001	-2.614	1.00	37.29	A3	ATOM 1072	H GLN 146	26.437	77.073	3.015	1.00	0.00	A3
ATOM 1037	C PHE 141	31.003	80.580	1.242	1.00	46.54	A3	ATOM 1073	CA GLN 146	27.660	76.263	1.511	1.00	38.01	A3
ATOM 1038	O PHE 141	31.584	80.664	2.317	1.00	48.26	A3	ATOM 1074	CB GLN 146	27.907	77.644	1.054	1.00	38.92	A3
ATOM 1039	N ALA 142	30.067	81.452	0.843	1.00	47.38	A3	ATOM 1075	CG GLN 146	26.884	78.066	0.049	1.00	43.26	A3
ATOM 1040	H ALA 142	29.624	81.295	-0.020	1.00	0.00	A3	ATOM 1076	CD GLN 146	27.171	79.440	-0.522	1.00	45.37	A3
ATOM 1041	CA ALA 142	29.581	82.564	1.668	1.00	46.06	A3	ATOM 1077	OE1 GLN 146	27.851	80.253	0.083	1.00	47.57	A3
ATOM 1042	CB ALA 142	28.731	83.546	0.879	1.00	45.04	A3	ATOM 1078	NE2 GLN 146	26.689	79.793	-1.692	1.00	47.50	A3

FIG. 5P

ATOM 1079	HE21	GLN	146	26.149	79.149	-2.190	1.00	0.00	A3	ATOM 1115	C	GLY	150	32.113	71.629	-0.478	1.00	31.39	A3
ATOM 1080	HE22	GLN	146	26.913	80.690	-2.021	1.00	0.00	A3	ATOM 1116	O	GLY	150	32.997	71.261	-1.265	1.00	31.77	A3
ATOM 1081	C	GLN	146	29.005	75.670	1.836	1.00	37.25	A3	ATOM 1117	N	GLY	151	32.075	71.161	0.773	1.00	29.83	A3
ATOM 1082	O	GLN	146	29.634	75.093	0.950	1.00	38.28	A3	ATOM 1118	H	GLY	151	31.412	71.524	1.394	1.00	0.00	A3
ATOM 1083	N	ARG	147	29.511	75.775	3.054	1.00	36.37	A3	ATOM 1119	CA	GLY	151	33.018	70.166	1.243	1.00	32.16	A3
ATOM 1084	H	ARG	147	29.044	76.300	3.738	1.00	0.00	A3	ATOM 1120	C	GLY	151	32.764	68.909	0.409	1.00	33.98	A3
ATOM 1085	CA	ARG	147	30.798	75.180	3.357	1.00	35.68	A3	ATOM 1121	O	GLY	151	33.664	68.501	-0.349	1.00	35.66	A3
ATOM 1086	CB	ARG	147	31.299	75.574	4.713	1.00	37.12	A3	ATOM 1122	N	VAL	152	31.486	68.418	0.451	1.00	31.87	A3
ATOM 1087	CG	ARG	147	31.730	77.016	4.697	1.00	42.68	A3	ATOM 1123	H	VAL	152	30.867	68.906	1.040	1.00	0.00	A3
ATOM 1088	CD	ARG	147	32.034	77.494	6.093	1.00	49.54	A3	ATOM 1124	CA	VAL	152	30.978	67.240	-0.275	1.00	29.61	A3
ATOM 1089	NE	ARG	147	32.674	78.774	5.877	1.00	58.21	A3	ATOM 1125	CB	VAL	152	29.419	67.145	-0.125	1.00	27.63	A3
ATOM 1090	HE	ARG	147	32.475	79.252	5.045	1.00	0.00	A3	ATOM 1126	CG1	VAL	152	28.883	66.035	-0.976	1.00	27.37	A3
ATOM 1091	CZ	ARG	147	33.519	79.373	6.742	1.00	62.77	A3	ATOM 1127	CG2	VAL	152	29.002	66.786	1.279	1.00	24.74	A3
ATOM 1092	NH1	ARG	147	33.905	78.868	7.936	1.00	63.96	A3	ATOM 1128	C	VAL	152	31.351	67.294	-1.762	1.00	29.91	A3
ATOM 1093	HH11	ARG	147	34.545	79.379	8.510	1.00	0.00	A3	ATOM 1129	O	VAL	152	31.805	66.329	-2.393	1.00	31.75	A3
ATOM 1094	HH12	ARG	147	33.561	77.980	8.239	1.00	0.00	A3	ATOM 1130	N	LEU	153	31.236	68.452	-2.361	1.00	29.26	A3
ATOM 1095	NH2	ARG	147	33.960	80.584	6.403	1.00	64.80	A3	ATOM 1131	H	LEU	153	30.881	69.219	-1.860	1.00	0.00	A3
ATOM 1096	HH21	ARG	147	34.599	81.069	6.999	1.00	0.00	A3	ATOM 1132	CA	LEU	153	31.559	68.607	-3.756	1.00	26.77	A3
ATOM 1097	HH22	ARG	147	33.665	80.996	5.541	1.00	0.00	A3	ATOM 1133	CB	LEU	153	30.881	69.858	-4.160	1.00	28.22	A3
ATOM 1098	C	ARG	147	30.570	73.702	3.337	1.00	34.91	A3	ATOM 1134	CG	LEU	153	29.943	69.894	-5.316	1.00	30.67	A3
ATOM 1099	O	ARG	147	31.233	73.050	2.539	1.00	34.56	A3	ATOM 1135	CD1	LEU	153	28.580	69.281	-5.090	1.00	26.48	A3
ATOM 1100	N	ALA	148	29.544	73.194	4.040	1.00	33.44	A3	ATOM 1136	CD2	LEU	153	29.741	71.365	-5.496	1.00	34.46	A3
ATOM 1101	H	ALA	148	28.926	73.818	4.482	1.00	0.00	A3	ATOM 1137	C	LEU	153	33.032	68.628	-4.111	1.00	26.08	A3
ATOM 1102	CA	ALA	148	29.358	71.754	4.172	1.00	33.92	A3	ATOM 1138	O	LEU	153	33.419	68.187	-5.212	1.00	26.78	A3
ATOM 1103	CB	ALA	148	28.217	71.426	5.163	1.00	32.85	A3	ATOM 1139	N	VAL	154	33.902	69.180	-3.269	1.00	26.12	A3
ATOM 1104	C	ALA	148	29.077	71.095	2.843	1.00	33.40	A3	ATOM 1140	H	VAL	154	33.589	69.557	-2.416	1.00	0.00	A3
ATOM 1105	O	ALA	148	29.765	70.141	2.457	1.00	34.31	A3	ATOM 1141	CA	VAL	154	35.330	69.259	-3.611	1.00	26.23	A3
ATOM 1106	N	ALA	149	28.169	71.657	2.077	1.00	32.60	A3	ATOM 1142	CB	VAL	154	36.057	70.299	-2.692	1.00	26.51	A3
ATOM 1107	H	ALA	149	27.662	72.424	2.411	1.00	0.00	A3	ATOM 1143	CG1	VAL	154	37.578	70.188	-2.942	1.00	25.01	A3
ATOM 1108	CA	ALA	149	27.890	71.134	0.757	1.00	32.70	A3	ATOM 1144	CG2	VAL	154	35.528	71.728	-2.945	1.00	27.82	A3
ATOM 1109	CB	ALA	149	26.595	71.774	0.299	1.00	31.91	A3	ATOM 1145	C	VAL	154	35.933	67.850	-3.375	1.00	26.80	A3
ATOM 1110	C	ALA	149	29.032	71.381	-0.258	1.00	33.75	A3	ATOM 1146	O	VAL	154	36.678	67.363	-4.229	1.00	26.27	A3
ATOM 1111	O	ALA	149	29.208	70.661	-1.264	1.00	34.49	A3	ATOM 1147	N	ALA	155	35.635	67.241	-2.199	1.00	24.76	A3
ATOM 1112	N	GLY	150	29.867	72.401	-0.052	1.00	33.58	A3	ATOM 1148	H	ALA	155	35.084	67.758	-1.570	1.00	0.00	A3
ATOM 1113	H	GLY	150	29.724	73.035	0.682	1.00	0.00	A3	ATOM 1149	CA	ALA	155	36.095	65.940	-1.782	1.00	25.21	A3
ATOM 1114	CA	GLY	150	31.017	72.608	-0.913	1.00	31.79	A3	ATOM 1150	CB	ALA	155	35.463	65.572	-0.457	1.00	25.25	A3

FIG. 50

ATOM 1151	C	ALA	155	35.708	64.946	-2.841	1.00	26.94	ATOM 1187	CG	GLN	159	37.064	60.063	-4.520	1.00	45.01	A3
ATOM 1152	O	ALA	155	36.594	64.288	-3.398	1.00	26.76	ATOM 1188	CD	GLN	159	37.755	59.611	-3.256	1.00	46.24	A3
ATOM 1153	N	SER	156	34.450	64.982	-3.282	1.00	29.96	ATOM 1189	OE1	GLN	159	38.142	58.443	-3.232	1.00	48.29	A3
ATOM 1154	H	SER	156	33.790	65.577	-2.868	1.00	0.00	ATOM 1190	NE2	GLN	159	37.936	60.456	-2.224	1.00	47.82	A3
ATOM 1155	CA	SER	156	34.034	64.105	-4.354	1.00	32.17	ATOM 1191	HE21	GLN	159	37.575	61.364	-2.289	1.00	0.00	A3
ATOM 1156	CB	SER	156	32.531	64.319	-4.544	1.00	34.23	ATOM 1192	HE22	GLN	159	38.412	60.101	-1.447	1.00	0.00	A3
ATOM 1157	OG	SER	156	32.000	64.195	-5.879	1.00	39.35	ATOM 1193	C	GLN	159	38.686	61.381	-6.921	1.00	36.24	A3
ATOM 1158	HG	SER	156	31.120	63.815	-5.851	1.00	0.00	ATOM 1194	O	GLN	159	39.632	60.690	-7.324	1.00	38.97	A3
ATOM 1159	C	SER	156	34.845	64.338	-5.632	1.00	33.46	ATOM 1195	N	SER	160	37.824	61.896	-7.796	1.00	35.48	A3
ATOM 1160	O	SER	156	35.411	63.380	-6.174	1.00	34.62	ATOM 1196	H	SER	160	37.142	62.540	-7.498	1.00	0.00	A3
ATOM 1161	N	HIS	157	35.054	65.576	-6.133	1.00	33.90	ATOM 1197	CA	SER	160	37.869	61.564	-9.203	1.00	34.96	A3
ATOM 1162	H	HIS	157	34.771	66.349	-5.605	1.00	0.00	ATOM 1198	CB	SER	160	36.645	62.100	-9.863	1.00	37.54	A3
ATOM 1163	CA	HIS	157	35.821	65.773	-7.383	1.00	31.19	ATOM 1199	OG	SER	160	35.587	62.434	-8.942	1.00	44.81	A3
ATOM 1164	CB	HIS	157	35.707	67.209	-7.900	1.00	32.59	ATOM 1200	HG	SER	160	35.340	61.689	-8.387	1.00	0.00	A3
ATOM 1165	CG	HIS	157	34.369	67.449	-8.566	1.00	31.11	ATOM 1201	C	SER	160	39.090	62.095	-9.922	1.00	34.65	A3
ATOM 1166	CD2	HIS	157	34.127	67.394	-9.928	1.00	30.78	ATOM 1202	O	SER	160	39.605	61.382	-10.785	1.00	35.42	A3
ATOM 1167	ND1	HIS	157	33.223	67.666	-7.942	1.00	32.36	ATOM 1203	N	PHE	161	39.615	63.293	-9.595	1.00	33.82	A3
ATOM 1168	HD1	HIS	157	33.080	67.773	-6.979	1.00	0.00	ATOM 1204	H	PHE	161	39.203	63.796	-8.864	1.00	0.00	A3
ATOM 1169	CE1	HIS	157	32.293	67.732	-8.875	1.00	32.01	ATOM 1205	CA	PHE	161	40.820	63.850	-10.218	1.00	31.21	A3
ATOM 1170	NE2	HIS	157	32.838	67.571	-10.060	1.00	29.18	ATOM 1206	CB	PHE	161	41.110	65.264	-9.629	1.00	28.28	A3
ATOM 1171	HE2	HIS	157	32.327	67.621	-10.895	1.00	0.00	ATOM 1207	CG	PHE	161	42.455	65.881	-10.062	1.00	24.92	A3
ATOM 1172	C	HIS	157	37.291	65.476	-7.269	1.00	29.68	ATOM 1208	CD1	PHE	161	42.696	66.228	-11.389	1.00	22.98	A3
ATOM 1173	O	HIS	157	37.950	65.059	-8.219	1.00	29.65	ATOM 1209	CD2	PHE	161	43.464	66.021	-9.135	1.00	23.03	A3
ATOM 1174	N	LEU	158	37.801	65.669	-6.071	1.00	29.24	ATOM 1210	CE1	PHE	161	43.941	66.695	-11.767	1.00	21.06	A3
ATOM 1175	H	LEU	158	37.213	65.901	-5.326	1.00	0.00	ATOM 1211	CE2	PHE	161	44.701	66.495	-9.528	1.00	20.28	A3
ATOM 1176	CA	LEU	158	39.216	65.479	-5.826	1.00	31.94	ATOM 1212	CZ	PHE	161	44.939	66.826	-10.832	1.00	17.03	A3
ATOM 1177	CB	LEU	158	39.609	65.949	-4.373	1.00	28.66	ATOM 1213	C	PHE	161	42.008	62.907	-9.943	1.00	31.77	A3
ATOM 1178	CG	LEU	158	41.008	65.751	-3.859	1.00	24.32	ATOM 1214	O	PHE	161	42.786	62.578	-10.845	1.00	32.63	A3
ATOM 1179	CD1	LEU	158	41.990	66.378	-4.776	1.00	20.87	ATOM 1215	N	LEU	162	42.117	62.434	-8.690	1.00	31.67	A3
ATOM 1180	CD2	LEU	158	41.099	66.330	-2.477	1.00	24.86	ATOM 1216	H	LEU	162	41.420	62.691	-8.054	1.00	0.00	A3
ATOM 1181	C	LEU	158	39.468	63.994	-6.027	1.00	31.46	ATOM 1217	CA	LEU	162	43.186	61.574	-8.232	1.00	31.29	A3
ATOM 1182	O	LEU	158	40.298	63.609	-6.844	1.00	30.58	ATOM 1218	CB	LEU	162	43.204	61.433	-6.743	1.00	25.84	A3
ATOM 1183	N	GLN	159	38.652	63.225	-5.340	1.00	33.54	ATOM 1219	CG	LEU	162	43.693	62.674	-6.003	1.00	26.02	A3
ATOM 1184	H	GLN	159	38.011	63.676	-4.748	1.00	0.00	ATOM 1220	CD1	LEU	162	43.594	62.455	-4.516	1.00	25.24	A3
ATOM 1185	CA	GLN	159	38.594	61.792	-5.442	1.00	35.73	ATOM 1221	CD2	LEU	162	45.107	62.994	-6.415	1.00	27.04	A3
ATOM 1186	CB	GLN	159	37.308	61.492	-4.813	1.00	37.26	ATOM 1222	C	LEU	162	43.061	60.212	-8.813	1.00	34.23	A3

FIG. 5R

ATOM 1223	O	LEU	162	44.107	59.654	-9.070	1.00	36.51	ATOM 1259	CZ	TYR	166	45.468	52.417	-9.862	1.00	75.71	A3
ATOM 1224	N	GLU	163	41.926	59.589	-9.082	1.00	37.24	ATOM 1260	OH	TYR	166	45.474	51.038	-10.016	1.00	80.61	A3
ATOM 1225	H	GLU	163	41.072	60.002	-8.826	1.00	0.00	ATOM 1261	HH	TYR	166	44.571	50.736	-10.134	1.00	0.00	A3
ATOM 1226	CA	GLU	163	41.975	58.327	-9.771	1.00	40.47	ATOM 1262	C	TYR	166	46.712	56.567	-11.987	1.00	62.34	A3
ATOM 1227	CB	GLU	163	40.566	57.716	-9.835	1.00	45.38	ATOM 1263	O	TYR	166	47.766	55.981	-12.282	1.00	63.25	A3
ATOM 1228	CG	GLU	163	40.264	56.975	-8.526	1.00	51.84	ATOM 1264	N	ALA	167	45.727	56.622	-12.884	1.00	61.27	A3
ATOM 1229	CD	GLU	163	41.291	55.889	-8.126	1.00	57.97	ATOM 1265	H	ALA	167	44.893	57.089	-12.678	1.00	0.00	A3
ATOM 1230	OE1	GLU	163	40.897	54.722	-8.092	1.00	62.01	ATOM 1266	CA	ALA	167	45.933	55.982	-14.159	1.00	61.47	A3
ATOM 1231	OE2	GLU	163	42.466	56.180	-7.832	1.00	59.17	ATOM 1267	CB	ALA	167	44.608	55.904	-14.904	1.00	60.98	A3
ATOM 1232	C	GLU	163	42.586	58.430	-11.142	1.00	41.34	ATOM 1268	C	ALA	167	46.982	56.694	-15.020	1.00	62.19	A3
ATOM 1233	O	GLU	163	43.456	57.633	-11.486	1.00	42.17	ATOM 1269	O	ALA	167	47.719	56.000	-15.734	1.00	62.63	A3
ATOM 1234	N	VAL	164	42.257	59.436	-11.920	1.00	42.28	ATOM 1270	N	VAL	168	47.210	58.011	-14.991	1.00	63.37	A3
ATOM 1235	H	VAL	164	41.589	60.091	-11.615	1.00	0.00	ATOM 1271	H	VAL	168	46.756	58.570	-14.330	1.00	0.00	A3
ATOM 1236	CA	VAL	164	42.911	59.609	-13.187	1.00	44.13	ATOM 1272	CA	VAL	168	48.174	58.593	-15.923	1.00	65.62	A3
ATOM 1237	CB	VAL	164	42.207	60.711	-13.940	1.00	45.52	ATOM 1273	CB	VAL	168	48.061	60.121	-16.131	1.00	66.30	A3
ATOM 1238	CG1	VAL	164	42.892	60.975	-15.278	1.00	48.79	ATOM 1274	CG1	VAL	168	46.687	60.431	-16.706	1.00	66.78	A3
ATOM 1239	CG2	VAL	164	40.786	60.269	-14.226	1.00	46.09	ATOM 1275	CG2	VAL	168	48.278	60.879	-14.840	1.00	68.47	A3
ATOM 1240	C	VAL	164	44.386	59.933	-12.991	1.00	46.13	ATOM 1276	C	VAL	168	49.579	58.339	-15.469	1.00	66.45	A3
ATOM 1241	O	VAL	164	45.192	59.473	-13.794	1.00	45.99	ATOM 1277	O	VAL	168	50.458	58.183	-16.302	1.00	66.22	A3
ATOM 1242	N	SER	165	44.879	60.677	-12.006	1.00	49.51	ATOM 1278	N	LEU	169	49.823	58.241	-14.177	1.00	68.83	A3
ATOM 1243	H	SER	165	44.287	61.173	-11.396	1.00	0.00	ATOM 1279	H	LEU	169	49.102	58.404	-13.536	1.00	0.00	A3
ATOM 1244	CA	SER	165	46.325	60.845	-11.895	1.00	53.44	ATOM 1280	CA	LEU	169	51.141	57.899	-13.695	1.00	71.81	A3
ATOM 1245	CB	SER	165	46.715	61.796	-10.775	1.00	54.77	ATOM 1281	CB	LEU	169	51.249	58.228	-12.188	1.00	71.53	A3
ATOM 1246	OG	SER	165	46.049	61.618	-9.530	1.00	59.99	ATOM 1282	CG	LEU	169	51.137	59.732	-11.813	1.00	70.68	A3
ATOM 1247	HG	SER	165	45.997	60.694	-9.261	1.00	0.00	ATOM 1283	CD1	LEU	169	51.187	59.826	-10.298	1.00	69.39	A3
ATOM 1248	C	SER	165	46.958	59.502	-11.630	1.00	55.15	ATOM 1284	CD2	LEU	169	52.223	60.580	-12.491	1.00	68.49	A3
ATOM 1249	O	SER	165	48.028	59.227	-12.148	1.00	55.02	ATOM 1285	C	LEU	169	51.333	56.414	-13.979	1.00	73.61	A3
ATOM 1250	N	TYR	166	46.239	58.645	-10.900	1.00	58.57	ATOM 1286	O	LEU	169	52.408	56.013	-14.429	1.00	74.75	A3
ATOM 1251	H	TYR	166	45.374	58.948	-10.549	1.00	0.00	ATOM 1287	N	ARG	170	50.309	55.583	-13.819	1.00	75.45	A3
ATOM 1252	CA	TYR	166	46.617	57.273	-10.625	1.00	61.42	ATOM 1288	H	ARG	170	49.488	55.923	-13.399	1.00	0.00	A3
ATOM 1253	CB	TYR	166	45.543	56.653	-9.680	1.00	64.05	ATOM 1289	CA	ARG	170	50.364	54.179	-14.199	1.00	78.17	A3
ATOM 1254	CG	TYR	166	45.502	55.138	-9.682	1.00	69.00	ATOM 1290	CB	ARG	170	48.944	53.642	-14.004	1.00	78.45	A3
ATOM 1255	CD1	TYR	166	44.389	54.501	-10.185	1.00	71.64	ATOM 1291	CG	ARG	170	48.394	52.506	-14.871	1.00	78.17	A3
ATOM 1256	CE1	TYR	166	44.367	53.130	-10.283	1.00	73.15	ATOM 1292	CD	ARG	170	48.744	51.181	-14.271	1.00	77.25	A3
ATOM 1257	CD2	TYR	166	46.594	54.409	-9.257	1.00	71.27	ATOM 1293	NE	ARG	170	48.123	51.120	-12.970	1.00	76.15	A3
ATOM 1258	CE2	TYR	166	46.584	53.040	-9.346	1.00	72.92	ATOM 1294	HE	ARG	170	47.245	51.528	-12.824	1.00	0.00	A3

FIG. 5S

ATOM 1295 CZ ARG 170	48.758	50.547	-11.970	1.00	76.14	A3	ATOM 1331 OT1 ALA 173	55.585	52.347	-16.971	1.00	87.21	A3
ATOM 1296 NH1 ARG 170	49.973	50.017	-12.112	1.00	76.84	A3	ATOM 1332 OT2 ALA 173	54.650	52.707	-15.036	1.00	87.31	A3
ATOM 1297 HH11 ARG 170	50.441	50.030	-12.994	1.00	0.00	A3	ATOM 1333 CB LEU 210	45.234	42.591	25.453	1.00	52.47	B1
ATOM 1298 HH12 ARG 170	50.406	49.570	-11.329	1.00	0.00	A3	ATOM 1334 CG LEU 210	43.799	42.058	25.547	1.00	51.68	B1
ATOM 1299 NH2 ARG 170	48.147	50.492	-10.806	1.00	77.02	A3	ATOM 1335 CD1 LEU 210	43.123	42.562	26.804	1.00	53.37	B1
ATOM 1300 HH21 ARG 170	47.237	50.890	-10.714	1.00	0.00	A3	ATOM 1336 CD2 LEU 210	43.050	42.453	24.303	1.00	51.37	B1
ATOM 1301 HH22 ARG 170	48.586	50.052	-10.023	1.00	0.00	A3	ATOM 1337 C LEU 210	46.770	44.374	24.596	1.00	50.98	B1
ATOM 1302 C ARG 170	50.870	54.052	-15.647	1.00	79.84	A3	ATOM 1338 O LEU 210	46.475	45.267	23.790	1.00	51.76	B1
ATOM 1303 O ARG 170	51.924	53.470	-15.908	1.00	80.07	A3	ATOM 1339 HT1 LEU 210	44.382	44.922	24.421	1.00	0.00	B1
ATOM 1304 N HIS 171	50.193	54.663	-16.611	1.00	81.38	A3	ATOM 1340 HT2 LEU 210	45.157	45.974	25.414	1.00	0.00	B1
ATOM 1305 H HIS 171	49.433	55.234	-16.359	1.00	0.00	A3	ATOM 1341 N LEU 210	44.705	45.041	25.406	1.00	53.59	B1
ATOM 1306 CA HIS 171	50.663	54.597	-17.970	1.00	84.03	A3	ATOM 1342 HT3 LEU 210	43.855	45.012	25.997	1.00	0.00	B1
ATOM 1307 CB HIS 171	49.590	55.054	-18.902	1.00	86.82	A3	ATOM 1343 CA LEU 210	45.730	44.038	25.676	1.00	52.35	B1
ATOM 1308 CG HIS 171	48.496	54.037	-19.147	1.00	90.73	A3	ATOM 1344 N PRO 211	47.974	43.825	24.494	1.00	49.35	B1
ATOM 1309 CD2 HIS 171	47.467	53.765	-18.272	1.00	91.35	A3	ATOM 1345 CD PRO 211	48.621	43.024	25.532	1.00	49.52	B1
ATOM 1310 ND1 HIS 171	48.308	53.301	-20.248	1.00	92.24	A3	ATOM 1346 CA PRO 211	48.895	44.191	23.419	1.00	49.04	B1
ATOM 1311 HD1 HIS 171	48.887	53.287	-21.044	1.00	0.00	A3	ATOM 1347 CB PRO 211	50.209	43.571	23.865	1.00	49.02	B1
ATOM 1312 CE1 HIS 171	47.204	52.605	-20.077	1.00	92.41	A3	ATOM 1348 CG PRO 211	49.794	42.438	24.783	1.00	49.77	B1
ATOM 1313 NE2 HIS 171	46.711	52.892	-18.891	1.00	92.59	A3	ATOM 1349 C PRO 211	48.543	43.864	21.965	1.00	48.03	B1
ATOM 1314 HE2 HIS 171	45.884	52.511	-18.518	1.00	0.00	A3	ATOM 1350 O PRO 211	47.872	42.896	21.622	1.00	49.05	B1
ATOM 1315 C HIS 171	51.907	55.446	-18.232	1.00	85.42	A3	ATOM 1351 N GLN 212	49.032	44.675	21.051	1.00	46.52	B1
ATOM 1316 O HIS 171	52.440	55.352	-19.344	1.00	85.98	A3	ATOM 1352 H GLN 212	49.506	45.478	21.349	1.00	0.00	B1
ATOM 1317 N LEU 172	52.359	56.307	-17.302	1.00	86.13	A3	ATOM 1353 CA GLN 212	48.839	44.461	19.641	1.00	45.47	B1
ATOM 1318 H LEU 172	51.870	56.411	-16.463	1.00	0.00	A3	ATOM 1354 CB GLN 212	49.533	45.522	18.849	1.00	46.81	B1
ATOM 1319 CA LEU 172	53.550	57.133	-17.496	1.00	86.02	A3	ATOM 1355 CG GLN 212	48.482	46.139	17.999	1.00	49.55	B1
ATOM 1320 CB LEU 172	53.500	58.357	-16.607	1.00	86.31	A3	ATOM 1356 CD GLN 212	49.024	46.703	16.709	1.00	54.21	B1
ATOM 1321 CG LEU 172	54.022	59.658	-17.203	1.00	87.48	A3	ATOM 1357 OE1 GLN 212	48.429	47.672	16.232	1.00	57.72	B1
ATOM 1322 CD1 LEU 172	53.436	59.939	-18.596	1.00	87.68	A3	ATOM 1358 NE2 GLN 212	50.086	46.176	16.074	1.00	52.39	B1
ATOM 1323 CD2 LEU 172	53.645	60.778	-16.251	1.00	87.95	A3	ATOM 1359 HE21 GLN 212	50.530	45.383	16.430	1.00	0.00	B1
ATOM 1324 C LEU 172	54.813	56.357	-17.180	1.00	85.92	A3	ATOM 1360 HE22 GLN 212	50.341	46.625	15.244	1.00	0.00	B1
ATOM 1325 O LEU 172	55.896	56.660	-17.692	1.00	86.23	A3	ATOM 1361 C GLN 212	49.390	43.133	19.185	1.00	44.79	B1
ATOM 1326 N ALA 173	54.733	55.383	-16.282	1.00	85.49	A3	ATOM 1362 O GLN 212	48.959	42.520	18.208	1.00	44.01	B1
ATOM 1327 H ALA 173	53.899	55.276	-15.769	1.00	0.00	A3	ATOM 1363 N SER 213	50.401	42.671	19.893	1.00	44.72	B1
ATOM 1328 CA ALA 173	55.856	54.497	-16.087	1.00	85.65	A3	ATOM 1364 H SER 213	50.790	43.115	20.698	1.00	0.00	B1
ATOM 1329 CB ALA 173	56.602	54.859	-14.809	1.00	85.01	A3	ATOM 1365 CA SER 213	51.025	41.424	19.521	1.00	43.76	B1
ATOM 1330 C ALA 173	55.330	53.073	-16.008	1.00	86.54	A3	ATOM 1366 CB SER 213	52.220	41.124	20.354	1.00	45.29	B1

FIG. 5T

ATOM 1367	OG SER 213	51.802	41.455	21.681	1.00	52.50	BI	ATOM 1403	CA LYS 217	48.067	36.439	17.599	1.00	34.90	BI
ATOM 1368	HG SER 213	52.479	41.127	22.288	1.00	0.00	BI	ATOM 1404	CB LYS 217	48.645	36.280	19.002	1.00	38.07	BI
ATOM 1369	C SER 213	50.014	40.376	19.784	1.00	40.92	BI	ATOM 1405	CG LYS 217	49.394	34.978	19.109	1.00	45.25	BI
ATOM 1370	O SER 213	49.964	39.492	18.947	1.00	43.32	BI	ATOM 1406	CD LYS 217	49.714	34.491	20.521	1.00	53.27	BI
ATOM 1371	N PHE 214	49.242	40.571	20.876	1.00	38.86	BI	ATOM 1407	CE LYS 217	50.229	33.024	20.297	1.00	59.03	BI
ATOM 1372	H PHE 214	49.414	41.370	21.410	1.00	0.00	BI	ATOM 1408	NZ LYS 217	50.213	32.135	21.467	1.00	62.10	BI
ATOM 1373	CA PHE 214	48.210	39.664	21.336	1.00	37.40	BI	ATOM 1409	HZ1 LYS 217	49.239	32.056	21.824	1.00	0.00	BI
ATOM 1374	CB PHE 214	47.568	40.064	22.634	1.00	37.45	BI	ATOM 1410	HZ2 LYS 217	50.830	32.515	22.214	1.00	0.00	BI
ATOM 1375	CG PHE 214	46.494	39.080	23.035	1.00	41.01	BI	ATOM 1411	HZ3 LYS 217	50.554	31.195	21.179	1.00	0.00	BI
ATOM 1376	CD1 PHE 214	45.176	39.459	23.044	1.00	42.77	BI	ATOM 1412	C LYS 217	46.617	35.950	17.546	1.00	36.77	BI
ATOM 1377	CD2 PHE 214	46.818	37.794	23.400	1.00	42.02	BI	ATOM 1413	O LYS 217	46.311	34.933	16.886	1.00	39.58	BI
ATOM 1378	CE1 PHE 214	44.197	38.554	23.423	1.00	41.82	BI	ATOM 1414	N CYS 218	45.664	36.638	18.177	1.00	34.86	BI
ATOM 1379	CE2 PHE 214	45.834	36.898	23.776	1.00	41.70	BI	ATOM 1415	H CYS 218	45.907	37.388	18.751	1.00	0.00	BI
ATOM 1380	CZ PHE 214	44.519	37.277	23.791	1.00	41.05	BI	ATOM 1416	CA CYS 218	44.277	36.238	18.076	1.00	33.61	BI
ATOM 1381	C PHE 214	47.109	39.656	20.321	1.00	36.54	BI	ATOM 1417	CB CYS 218	43.430	37.175	18.846	1.00	33.21	BI
ATOM 1382	O PHE 214	46.735	38.566	19.889	1.00	37.99	BI	ATOM 1418	SG CYS 218	43.856	36.710	20.515	1.00	35.92	BI
ATOM 1383	N LEU 215	46.616	40.812	19.893	1.00	33.27	BI	ATOM 1419	C CYS 218	43.766	36.189	16.652	1.00	32.89	BI
ATOM 1384	H LEU 215	47.008	41.642	20.238	1.00	0.00	BI	ATOM 1420	O CYS 218	43.155	35.169	16.323	1.00	34.71	BI
ATOM 1385	CA LEU 215	45.504	40.864	18.966	1.00	30.38	BI	ATOM 1421	N LEU 219	44.035	37.169	15.777	1.00	29.52	BI
ATOM 1386	CB LEU 215	45.099	42.282	18.701	1.00	31.82	BI	ATOM 1422	H LEU 219	44.512	37.960	16.104	1.00	0.00	BI
ATOM 1387	CG LEU 215	43.857	42.530	17.893	1.00	32.78	BI	ATOM 1423	CA LEU 219	43.614	37.119	14.393	1.00	27.44	BI
ATOM 1388	CD1 LEU 215	42.727	41.963	18.737	1.00	32.95	BI	ATOM 1424	CB LEU 219	44.116	38.412	13.727	1.00	26.24	BI
ATOM 1389	CD2 LEU 215	43.688	44.011	17.508	1.00	28.93	BI	ATOM 1425	CG LEU 219	43.884	38.768	12.241	1.00	25.07	BI
ATOM 1390	C LEU 215	45.811	40.232	17.648	1.00	29.57	BI	ATOM 1426	CD1 LEU 219	42.402	38.975	11.996	1.00	26.24	BI
ATOM 1391	O LEU 215	44.922	39.632	17.055	1.00	31.28	BI	ATOM 1427	CD2 LEU 219	44.563	40.051	11.882	1.00	22.10	BI
ATOM 1392	N LEU 216	47.031	40.379	17.155	1.00	29.44	BI	ATOM 1428	C LEU 219	44.121	35.867	13.634	1.00	28.24	BI
ATOM 1393	H LEU 216	47.677	40.935	17.646	1.00	0.00	BI	ATOM 1429	O LEU 219	43.373	35.204	12.889	1.00	27.12	BI
ATOM 1394	CA LEU 216	47.465	39.790	15.893	1.00	29.89	BI	ATOM 1430	N GLU 220	45.399	35.499	13.795	1.00	28.06	BI
ATOM 1395	CB LEU 216	48.791	40.450	15.472	1.00	28.61	BI	ATOM 1431	H GLU 220	45.957	35.974	14.448	1.00	0.00	BI
ATOM 1396	CG LEU 216	48.682	41.877	14.939	1.00	26.83	BI	ATOM 1432	CA GLU 220	45.963	34.411	13.048	1.00	28.38	BI
ATOM 1397	CD1 LEU 216	49.925	42.558	15.344	1.00	28.57	BI	ATOM 1433	CB GLU 220	47.376	34.198	13.469	1.00	34.25	BI
ATOM 1398	CD2 LEU 216	48.446	41.950	13.452	1.00	24.09	BI	ATOM 1434	CG GLU 220	48.049	33.079	12.666	1.00	46.36	BI
ATOM 1399	C LEU 216	47.613	38.274	16.062	1.00	31.23	BI	ATOM 1435	CD GLU 220	49.545	32.794	12.907	1.00	55.51	BI
ATOM 1400	O LEU 216	47.328	37.514	15.138	1.00	29.20	BI	ATOM 1436	OE1 GLU 220	50.113	32.133	12.021	1.00	58.95	BI
ATOM 1401	N LYS 217	47.999	37.826	17.261	1.00	32.50	BI	ATOM 1437	OE2 GLU 220	50.144	33.213	13.930	1.00	60.41	BI
ATOM 1402	H LYS 217	48.305	38.482	17.926	1.00	0.00	BI	ATOM 1438	C GLU 220	45.134	33.193	13.354	1.00	27.30	BI

FIG. 5U

ATOM 1439	O	GLU	220	44.662	32.524	12.437	1.00	27.08	B1	ATOM 1475	C	ARG	223	41.624	31.492	10.430	1.00	29.13	B1
ATOM 1440	N	GLN	221	44.866	33.023	14.642	1.00	25.42	B1	ATOM 1476	O	ARG	223	41.181	30.987	9.376	1.00	29.32	B1
ATOM 1441	H	GLN	221	45.229	33.687	15.268	1.00	0.00	B1	ATOM 1477	N	LYS	224	42.413	30.791	11.259	1.00	29.17	B1
ATOM 1442	CA	GLN	221	44.074	31.940	15.176	1.00	26.28	B1	ATOM 1478	H	LYS	224	42.791	31.235	12.048	1.00	0.00	B1
ATOM 1443	CB	GLN	221	44.143	31.927	16.691	1.00	26.78	B1	ATOM 1479	CA	LYS	224	42.714	29.411	10.994	1.00	27.70	B1
ATOM 1444	CG	GLN	221	45.555	31.456	17.011	1.00	29.19	B1	ATOM 1480	CB	LYS	224	43.922	29.085	11.818	1.00	30.07	B1
ATOM 1445	CD	GLN	221	45.752	31.067	18.442	1.00	31.98	B1	ATOM 1481	CG	LYS	224	44.372	27.660	11.706	1.00	36.70	B1
ATOM 1446	OE1	GLN	221	46.472	30.162	18.808	1.00	35.98	B1	ATOM 1482	CD	LYS	224	45.829	27.544	12.127	1.00	41.68	B1
ATOM 1447	NE2	GLN	221	45.110	31.736	19.347	1.00	39.31	B1	ATOM 1483	CE	LYS	224	46.303	26.478	11.131	1.00	48.18	B1
ATOM 1448	HE21	GLN	221	45.263	31.423	20.246	1.00	0.00	B1	ATOM 1484	NZ	LYS	224	47.750	26.492	10.913	1.00	53.57	B1
ATOM 1449	HE22	GLN	221	44.571	32.514	19.111	1.00	0.00	B1	ATOM 1485	HZ1	LYS	224	48.230	26.241	11.801	1.00	0.00	B1
ATOM 1450	C	GLN	221	42.615	31.925	14.789	1.00	26.21	B1	ATOM 1486	HZ2	LYS	224	48.057	27.436	10.606	1.00	0.00	B1
ATOM 1451	O	GLN	221	42.186	30.896	14.269	1.00	30.69	B1	ATOM 1487	HZ3	LYS	224	47.998	25.792	10.183	1.00	0.00	B1
ATOM 1452	N	VAL	222	41.814	32.962	14.984	1.00	23.63	B1	ATOM 1488	C	LYS	224	41.464	28.598	11.347	1.00	26.27	B1
ATOM 1453	H	VAL	222	42.199	33.746	15.426	1.00	0.00	B1	ATOM 1489	O	LYS	224	40.970	27.810	10.510	1.00	24.82	B1
ATOM 1454	CA	VAL	222	40.429	33.034	14.537	1.00	21.92	B1	ATOM 1490	N	ILE	225	40.892	28.835	12.547	1.00	24.75	B1
ATOM 1455	CB	VAL	222	39.934	34.442	14.793	1.00	21.36	B1	ATOM 1491	H	ILE	225	41.308	29.487	13.151	1.00	0.00	B1
ATOM 1456	CG1	VAL	222	38.706	34.831	14.027	1.00	17.72	B1	ATOM 1492	CA	ILE	225	39.656	28.147	12.943	1.00	23.33	B1
ATOM 1457	CG2	VAL	222	39.671	34.496	16.257	1.00	20.95	B1	ATOM 1493	CB	ILE	225	39.146	28.622	14.296	1.00	18.08	B1
ATOM 1458	C	VAL	222	40.374	32.707	13.066	1.00	22.65	B1	ATOM 1494	CG2	ILE	225	37.874	27.872	14.577	1.00	15.43	B1
ATOM 1459	O	VAL	222	39.475	32.013	12.632	1.00	23.72	B1	ATOM 1495	CG1	ILE	225	40.161	28.400	15.380	1.00	13.38	B1
ATOM 1460	N	ARG	223	41.341	33.120	12.283	1.00	23.95	B1	ATOM 1496	CD	ILE	225	39.787	28.967	16.749	1.00	13.59	B1
ATOM 1461	H	ARG	223	42.099	33.614	12.666	1.00	0.00	B1	ATOM 1497	C	ILE	225	38.594	28.437	11.889	1.00	27.28	B1
ATOM 1462	CA	ARG	223	41.309	32.939	10.844	1.00	27.19	B1	ATOM 1498	O	ILE	225	37.978	27.492	11.400	1.00	31.49	B1
ATOM 1463	CB	ARG	223	42.294	33.935	10.283	1.00	29.26	B1	ATOM 1499	N	GLN	226	38.396	29.677	11.402	1.00	29.69	B1
ATOM 1464	CG	ARG	223	42.102	34.364	8.869	1.00	35.23	B1	ATOM 1500	H	GLN	226	38.894	30.413	11.803	1.00	0.00	B1
ATOM 1465	CD	ARG	223	42.880	33.487	7.929	1.00	41.88	B1	ATOM 1501	CA	GLN	226	37.450	29.969	10.313	1.00	29.12	B1
ATOM 1466	NE	ARG	223	41.972	32.676	7.096	1.00	47.42	B1	ATOM 1502	CB	GLN	226	37.366	31.438	9.962	1.00	32.26	B1
ATOM 1467	HE	ARG	223	41.451	31.953	7.502	1.00	0.00	B1	ATOM 1503	CG	GLN	226	36.682	32.156	11.108	1.00	36.28	B1
ATOM 1468	CZ	ARG	223	41.875	32.896	5.784	1.00	46.15	B1	ATOM 1504	CD	GLN	226	36.429	33.613	10.816	1.00	37.88	B1
ATOM 1469	NH1	ARG	223	42.575	33.837	5.246	1.00	49.54	B1	ATOM 1505	OE1	GLN	226	37.158	34.281	10.076	1.00	36.34	B1
ATOM 1470	HH11	ARG	223	42.522	33.989	4.259	1.00	0.00	B1	ATOM 1506	NE2	GLN	226	35.359	34.114	11.421	1.00	39.62	B1
ATOM 1471	HH12	ARG	223	43.156	34.428	5.805	1.00	0.00	B1	ATOM 1507	HE21	GLN	226	34.823	33.501	11.971	1.00	0.00	B1
ATOM 1472	NH2	ARG	223	41.178	32.161	4.952	1.00	45.74	B1	ATOM 1508	HE22	GLN	226	35.153	35.057	11.287	1.00	0.00	B1
ATOM 1473	HH21	ARG	223	40.697	31.353	5.290	1.00	0.00	B1	ATOM 1509	C	GLN	226	37.714	29.295	9.007	1.00	26.82	B1
ATOM 1474	HH22	ARG	223	41.154	32.399	3.980	1.00	0.00	B1	ATOM 1510	O	GLN	226	36.775	28.887	8.325	1.00	27.45	B1

FIG. 5V

ATOM 1511	N	GLY	227	38.940	29.186	8.570	1.00	26.55	BI	ATOM 1547	CD1	LEU	232	33.191	19.545	9.451	1.00	34.59	BI
ATOM 1512	H	GLY	227	39.688	29.612	9.043	1.00	0.00	BI	ATOM 1548	CD2	LEU	232	32.107	21.381	10.800	1.00	31.32	BI
ATOM 1513	CA	GLY	227	39.195	28.427	7.348	1.00	27.27	BI	ATOM 1549	C	LEU	232	32.271	21.829	6.440	1.00	36.65	BI
ATOM 1514	C	GLY	227	38.832	26.949	7.574	1.00	27.65	BI	ATOM 1550	O	LEU	232	31.703	20.986	5.749	1.00	36.42	BI
ATOM 1515	O	GLY	227	38.287	26.291	6.656	1.00	26.79	BI	ATOM 1551	N	GLN	233	31.836	23.084	6.570	1.00	38.89	BI
ATOM 1516	N	ASP	228	39.025	26.429	8.819	1.00	27.03	BI	ATOM 1552	H	GLN	233	32.378	23.719	7.087	1.00	0.00	BI
ATOM 1517	H	ASP	228	39.460	26.957	9.523	1.00	0.00	BI	ATOM 1553	CA	GLN	233	30.637	23.579	5.933	1.00	40.02	BI
ATOM 1518	CA	ASP	228	38.618	25.038	9.052	1.00	28.20	BI	ATOM 1554	CB	GLN	233	30.572	25.072	6.162	1.00	42.25	BI
ATOM 1519	CB	ASP	228	38.986	24.492	10.391	1.00	26.04	BI	ATOM 1555	CG	GLN	233	30.290	25.398	7.626	1.00	48.22	BI
ATOM 1520	CG	ASP	228	40.427	24.554	10.774	1.00	24.88	BI	ATOM 1556	CD	GLN	233	30.021	26.879	7.983	1.00	53.75	BI
ATOM 1521	OD1	ASP	228	40.627	24.521	11.977	1.00	23.37	BI	ATOM 1557	OE1	GLN	233	30.799	27.810	7.718	1.00	55.93	BI
ATOM 1522	OD2	ASP	228	41.302	24.637	9.912	1.00	23.32	BI	ATOM 1558	NE2	GLN	233	28.909	27.215	8.634	1.00	56.51	BI
ATOM 1523	C	ASP	228	37.120	24.830	8.992	1.00	27.23	BI	ATOM 1559	HE21	GLN	233	28.810	28.144	8.902	1.00	0.00	BI
ATOM 1524	O	ASP	228	36.662	23.900	8.336	1.00	27.07	BI	ATOM 1560	HE22	GLN	233	28.205	26.533	8.710	1.00	0.00	BI
ATOM 1525	N	GLY	229	36.390	25.739	9.639	1.00	26.74	BI	ATOM 1561	C	GLN	233	30.635	23.243	4.441	1.00	39.70	BI
ATOM 1526	H	GLY	229	36.861	26.444	10.134	1.00	0.00	BI	ATOM 1562	O	GLN	233	29.631	22.777	3.898	1.00	40.20	BI
ATOM 1527	CA	GLY	229	34.946	25.723	9.673	1.00	25.87	BI	ATOM 1563	N	GLU	234	31.744	23.377	3.736	1.00	39.32	BI
ATOM 1528	C	GLY	229	34.393	25.825	8.274	1.00	24.95	BI	ATOM 1564	H	GLU	234	32.544	23.750	4.163	1.00	0.00	BI
ATOM 1529	O	GLY	229	33.370	25.222	7.956	1.00	25.73	BI	ATOM 1565	CA	GLU	234	31.809	23.025	2.329	1.00	39.23	BI
ATOM 1530	N	ALA	230	35.058	26.541	7.391	1.00	23.97	BI	ATOM 1566	CB	GLU	234	33.155	23.434	1.811	1.00	40.25	BI
ATOM 1531	H	ALA	230	35.871	27.026	7.654	1.00	0.00	BI	ATOM 1567	CG	GLU	234	33.292	23.028	0.383	1.00	47.69	BI
ATOM 1532	CA	ALA	230	34.530	26.688	6.061	1.00	25.94	BI	ATOM 1568	CD	GLU	234	34.733	23.056	-0.073	1.00	53.40	BI
ATOM 1533	CB	ALA	230	35.193	27.852	5.312	1.00	19.76	BI	ATOM 1569	OE1	GLU	234	34.986	23.721	-1.100	1.00	53.78	BI
ATOM 1534	C	ALA	230	34.794	25.403	5.304	1.00	29.42	BI	ATOM 1570	OE2	GLU	234	35.568	22.400	0.590	1.00	57.55	BI
ATOM 1535	O	ALA	230	34.014	25.061	4.423	1.00	32.07	BI	ATOM 1571	C	GLU	234	31.580	21.535	2.136	1.00	37.09	BI
ATOM 1536	N	ALA	231	35.878	24.671	5.572	1.00	32.16	BI	ATOM 1572	O	GLU	234	30.884	21.217	1.188	1.00	36.67	BI
ATOM 1537	H	ALA	231	36.556	25.045	6.175	1.00	0.00	BI	ATOM 1573	N	LYS	235	32.092	20.623	2.986	1.00	37.27	BI
ATOM 1538	CA	ALA	231	36.141	23.364	4.957	1.00	31.99	BI	ATOM 1574	H	LYS	235	32.668	20.965	3.706	1.00	0.00	BI
ATOM 1539	CB	ALA	231	37.489	22.847	5.428	1.00	32.77	BI	ATOM 1575	CA	LYS	235	31.832	19.177	2.942	1.00	36.27	BI
ATOM 1540	C	ALA	231	35.060	22.361	5.386	1.00	32.99	BI	ATOM 1576	CB	LYS	235	32.516	18.365	3.997	1.00	34.92	BI
ATOM 1541	O	ALA	231	34.599	21.575	4.576	1.00	34.12	BI	ATOM 1577	CG	LYS	235	33.978	18.483	4.107	1.00	38.47	BI
ATOM 1542	N	LEU	232	34.662	22.309	6.652	1.00	33.30	BI	ATOM 1578	CD	LYS	235	34.762	17.999	2.921	1.00	38.07	BI
ATOM 1543	H	LEU	232	35.174	22.861	7.284	1.00	0.00	BI	ATOM 1579	CE	LYS	235	36.192	18.051	3.460	1.00	39.15	BI
ATOM 1544	CA	LEU	232	33.558	21.506	7.165	1.00	35.33	BI	ATOM 1580	NZ	LYS	235	37.117	17.460	2.521	1.00	41.34	BI
ATOM 1545	CB	LEU	232	33.279	21.783	8.626	1.00	34.22	BI	ATOM 1581	HZ1	LYS	235	37.080	17.978	1.622	1.00	0.00	BI
ATOM 1546	CG	LEU	232	32.410	20.861	9.394	1.00	33.16	BI	ATOM 1582	HZ2	LYS	235	36.854	16.466	2.363	1.00	0.00	BI

FIG. 5W

ATOM 1583	HZ3 LYS 235	38.080	17.497	2.911	1.00	0.00	BI
ATOM 1584	C LYS 235	30.363	18.847	3.204	1.00	35.20	BI
ATOM 1585	O LYS 235	29.722	18.102	2.463	1.00	35.60	BI
ATOM 1586	N LEU 236	29.807	19.332	4.301	1.00	33.53	BI
ATOM 1587	H LEU 236	30.363	19.888	4.885	1.00	0.00	BI
ATOM 1588	CA LEU 236	28.417	19.116	4.641	1.00	32.30	BI
ATOM 1589	CB LEU 236	28.093	19.918	5.894	1.00	28.85	BI
ATOM 1590	CG LEU 236	28.791	19.441	7.148	1.00	28.23	BI
ATOM 1591	CD1 LEU 236	28.703	20.460	8.268	1.00	24.14	BI
ATOM 1592	CD2 LEU 236	28.132	18.163	7.587	1.00	26.66	BI
ATOM 1593	C LEU 236	27.590	19.574	3.453	1.00	33.69	BI
ATOM 1594	O LEU 236	26.691	18.849	3.064	1.00	35.13	BI
ATOM 1595	N CYS 237	27.870	20.670	2.753	1.00	34.49	BI
ATOM 1596	H CYS 237	28.611	21.251	3.025	1.00	0.00	BI
ATOM 1597	CA CYS 237	27.064	21.016	1.606	1.00	34.95	BI
ATOM 1598	C CYS 237	27.324	20.090	0.451	1.00	35.97	BI
ATOM 1599	O CYS 237	26.360	19.573	-0.089	1.00	36.09	BI
ATOM 1600	CB CYS 237	27.334	22.413	1.130	1.00	35.18	BI
ATOM 1601	SG CYS 237	26.409	22.880	-0.365	1.00	36.40	BI
ATOM 1602	N ALA 238	28.571	19.804	0.074	1.00	37.29	BI
ATOM 1603	H ALA 238	29.324	20.158	0.591	1.00	0.00	BI
ATOM 1604	CA ALA 238	28.841	18.973	-1.090	1.00	36.80	BI
ATOM 1605	CB ALA 238	30.274	18.684	-1.403	1.00	37.35	BI
ATOM 1606	C ALA 238	28.320	17.617	-0.911	1.00	36.49	BI
ATOM 1607	O ALA 238	27.645	17.198	-1.809	1.00	36.54	BI
ATOM 1608	N THR 239	28.628	16.969	0.193	1.00	38.80	BI
ATOM 1609	H THR 239	29.236	17.391	0.821	1.00	0.00	BI
ATOM 1610	CA THR 239	28.230	15.587	0.464	1.00	41.33	BI
ATOM 1611	CB THR 239	29.158	15.035	1.554	1.00	42.38	BI
ATOM 1612	OG1 THR 239	30.473	15.265	1.031	1.00	45.70	BI
ATOM 1613	HG1 THR 239	31.019	15.668	1.709	1.00	0.00	BI
ATOM 1614	CG2 THR 239	28.936	13.574	1.916	1.00	41.85	BI
ATOM 1615	C THR 239	26.771	15.341	0.864	1.00	41.94	BI
ATOM 1616	O THR 239	26.260	14.284	0.460	1.00	43.34	BI
ATOM 1617	N TYR 240	26.095	16.207	1.669	1.00	40.07	BI
ATOM 1618	H TYR 240	26.538	17.034	1.953	1.00	0.00	BI
ATOM 1619	CA TYR 240	24.718	15.992	2.084	1.00	38.21	BI
ATOM 1620	CB TYR 240	24.594	15.993	3.618	1.00	38.08	BI
ATOM 1621	CG TYR 240	25.524	14.926	4.193	1.00	43.37	BI
ATOM 1622	CD1 TYR 240	26.475	15.243	5.149	1.00	45.06	BI
ATOM 1623	CE1 TYR 240	27.420	14.283	5.529	1.00	47.35	BI
ATOM 1624	CD2 TYR 240	25.518	13.643	3.641	1.00	43.89	BI
ATOM 1625	CE2 TYR 240	26.442	12.690	4.003	1.00	44.77	BI
ATOM 1626	CZ TYR 240	27.410	13.005	4.943	1.00	47.96	BI
ATOM 1627	OH TYR 240	28.390	12.047	5.244	1.00	46.59	BI
ATOM 1628	HH TYR 240	28.027	11.187	4.992	1.00	0.00	BI
ATOM 1629	C TYR 240	23.781	17.032	1.516	1.00	39.49	BI
ATOM 1630	O TYR 240	22.587	16.934	1.775	1.00	42.76	BI
ATOM 1631	N LYS 241	24.174	18.011	0.694	1.00	37.36	BI
ATOM 1632	H LYS 241	25.091	18.023	0.345	1.00	0.00	BI
ATOM 1633	CA LYS 241	23.314	19.115	0.275	1.00	36.37	BI
ATOM 1634	CB LYS 241	22.173	18.648	-0.595	1.00	38.38	BI
ATOM 1635	CG LYS 241	22.645	17.940	-1.838	1.00	42.94	BI
ATOM 1636	CD LYS 241	23.468	18.809	-2.737	1.00	46.97	BI
ATOM 1637	CE LYS 241	23.657	18.070	-4.051	1.00	49.20	BI
ATOM 1638	NZ LYS 241	22.509	18.372	-4.893	1.00	51.54	BI
ATOM 1639	HZ1 LYS 241	22.447	19.400	-5.038	1.00	0.00	BI
ATOM 1640	HZ2 LYS 241	21.641	18.041	-4.426	1.00	0.00	BI
ATOM 1641	HZ3 LYS 241	22.609	17.895	-5.811	1.00	0.00	BI
ATOM 1642	C LYS 241	22.720	19.904	1.429	1.00	33.37	BI
ATOM 1643	O LYS 241	21.728	20.580	1.223	1.00	33.90	BI
ATOM 1644	N LEU 242	23.286	19.853	2.648	1.00	31.40	BI
ATOM 1645	H LEU 242	24.055	19.260	2.756	1.00	0.00	BI
ATOM 1646	CA LEU 242	22.904	20.682	3.758	1.00	31.09	BI
ATOM 1647	CB LEU 242	23.253	20.059	5.096	1.00	28.55	BI
ATOM 1648	CG LEU 242	22.571	18.798	5.641	1.00	30.36	BI
ATOM 1649	CD1 LEU 242	22.530	18.814	7.138	1.00	29.62	BI
ATOM 1650	CD2 LEU 242	21.086	18.861	5.443	1.00	31.94	BI
ATOM 1651	C LEU 242	23.778	21.933	3.550	1.00	34.03	BI
ATOM 1652	O LEU 242	24.903	22.027	4.058	1.00	35.53	BI
ATOM 1653	N CYS 243	23.316	22.883	2.722	1.00	34.89	BI
ATOM 1654	H CYS 243	22.491	22.665	2.238	1.00	0.00	BI

FIG. 5X

ATOM 1655	CA	CYS	243	24.051	24.083	2.377	1.00	35.42	18.750	27.334	6.190	1.00	0.00	B1
ATOM 1656	C	CYS	243	23.492	25.335	2.975	1.00	36.85	17.001	26.347	6.830	1.00	40.76	B1
ATOM 1657	O	CYS	243	23.956	26.400	2.565	1.00	40.10	17.139	25.423	5.642	1.00	44.03	B1
ATOM 1658	CB	CYS	243	24.046	24.383	0.929	1.00	33.12	16.830	26.240	4.400	1.00	48.54	B1
ATOM 1659	SG	CYS	243	24.438	22.883	0.099	1.00	38.25	17.163	25.628	3.050	1.00	50.24	B1
ATOM 1660	N	HIS	244	22.496	25.393	3.848	1.00	35.37	16.849	26.299	2.056	1.00	52.92	B1
ATOM 1661	H	HIS	244	22.185	24.588	4.318	1.00	0.00	17.744	24.533	2.987	1.00	50.84	B1
ATOM 1662	CA	HIS	244	21.939	26.676	4.191	1.00	33.29	16.966	25.444	8.034	1.00	39.24	B1
ATOM 1663	CB	HIS	244	20.655	26.987	3.340	1.00	33.64	15.915	24.888	8.329	1.00	39.40	B1
ATOM 1664	CG	HIS	244	20.915	27.205	1.857	1.00	33.12	18.066	25.280	8.760	1.00	37.92	B1
ATOM 1665	CD	HIS	244	20.288	26.584	0.814	1.00	37.29	18.864	25.814	8.576	1.00	0.00	B1
ATOM 1666	ND	HIS	244	21.874	27.902	1.298	1.00	36.85	18.101	24.338	9.858	1.00	35.75	B1
ATOM 1667	HD	HIS	244	22.648	28.281	1.778	1.00	0.00	19.458	23.623	9.796	1.00	34.13	B1
ATOM 1668	CE	HIS	244	21.874	27.722	-0.013	1.00	35.95	19.669	22.866	8.430	1.00	34.00	B1
ATOM 1669	NE	HIS	244	20.910	26.920	-0.301	1.00	35.54	20.997	22.149	8.306	1.00	33.97	B1
ATOM 1670	HE	HIS	244	20.616	26.706	-1.214	1.00	0.00	18.620	21.810	8.322	1.00	32.33	B1
ATOM 1671	C	HIS	244	21.621	26.565	5.650	1.00	33.38	17.871	25.031	11.155	1.00	36.51	B1
ATOM 1672	O	HIS	244	20.546	26.105	6.029	1.00	33.23	17.736	24.370	12.186	1.00	36.31	B1
ATOM 1673	N	PRO	245	22.539	27.018	6.499	1.00	33.21	17.663	26.350	11.146	1.00	38.88	B1
ATOM 1674	CD	PRO	245	23.851	27.524	6.099	1.00	31.29	17.566	26.810	10.283	1.00	0.00	B1
ATOM 1675	CA	PRO	245	22.373	26.979	7.948	1.00	34.16	17.573	27.133	12.371	1.00	41.39	B1
ATOM 1676	CB	PRO	245	23.490	27.799	8.467	1.00	32.85	17.265	28.640	12.020	1.00	43.72	B1
ATOM 1677	CG	PRO	245	24.564	27.549	7.428	1.00	31.74	15.804	28.985	11.776	1.00	44.70	B1
ATOM 1678	C	PRO	245	21.032	27.470	8.407	1.00	36.26	17.702	29.434	13.214	1.00	45.20	B1
ATOM 1679	O	PRO	245	20.478	26.878	9.315	1.00	38.13	16.590	26.635	13.406	1.00	42.61	B1
ATOM 1680	N	GLU	246	20.529	28.463	7.640	1.00	39.64	16.912	26.716	14.594	1.00	44.77	B1
ATOM 1681	H	GLU	246	21.134	28.747	6.934	1.00	0.00	15.453	26.035	13.016	1.00	43.61	B1
ATOM 1682	CA	GLU	246	19.257	29.229	7.711	1.00	41.10	15.319	25.919	12.053	1.00	0.00	B1
ATOM 1683	CB	GLU	246	19.044	30.107	6.438	1.00	43.15	14.457	25.537	13.987	1.00	43.96	B1
ATOM 1684	CG	GLU	246	20.256	30.918	5.944	1.00	47.07	13.102	25.296	13.373	1.00	43.88	B1
ATOM 1685	CD	GLU	246	20.813	30.539	4.558	1.00	52.63	12.729	26.281	12.313	1.00	47.04	B1
ATOM 1686	OE	GLU	246	22.054	30.545	4.374	1.00	54.22	13.092	25.577	11.011	1.00	47.30	B1
ATOM 1687	OE	GLU	246	20.002	30.250	3.656	1.00	53.39	11.286	26.772	12.441	1.00	46.18	B1
ATOM 1688	C	GLU	246	18.071	28.298	7.819	1.00	40.57	14.852	24.207	14.626	1.00	43.96	B1
ATOM 1689	O	GLU	246	17.308	28.338	8.791	1.00	39.90	14.450	23.887	15.764	1.00	44.07	B1
ATOM 1690	N	GLU	247	18.025	27.388	6.840	1.00	40.32	15.691	23.446	13.893	1.00	42.41	B1

FIG. 5Y

ATOM 1727	H LEU 251	16.049	23.788	13.048	1.00	0.00	BI	ATOM 1763	CA LEU 255	18.913	19.272	18.723	1.00	46.02	BI
ATOM 1728	CA LEU 251	16.155	22.159	14.362	1.00	40.63	BI	ATOM 1764	CB LEU 255	19.706	19.723	17.537	1.00	44.66	BI
ATOM 1729	CB LEU 251	16.834	21.418	13.257	1.00	36.17	BI	ATOM 1765	CG LEU 255	19.362	18.968	16.274	1.00	44.51	BI
ATOM 1730	CG LEU 251	15.996	20.629	12.267	1.00	33.16	BI	ATOM 1766	CD1 LEU 255	19.810	19.679	15.006	1.00	43.16	BI
ATOM 1731	CD1 LEU 251	14.595	21.168	11.956	1.00	33.36	BI	ATOM 1767	CD2 LEU 255	19.969	17.604	16.456	1.00	44.67	BI
ATOM 1732	CD2 LEU 251	16.875	20.619	11.050	1.00	34.71	BI	ATOM 1768	C LEU 255	19.536	19.718	20.012	1.00	46.56	BI
ATOM 1733	C LEU 251	17.104	22.372	15.493	1.00	42.78	BI	ATOM 1769	O LEU 255	20.565	19.174	20.440	1.00	46.82	BI
ATOM 1734	O LEU 251	17.124	21.554	16.395	1.00	45.44	BI	ATOM 1770	N GLY 256	18.918	20.759	20.581	1.00	45.93	BI
ATOM 1735	N GLY 252	17.826	23.477	15.610	1.00	44.86	BI	ATOM 1771	H GLY 256	18.210	21.225	20.101	1.00	0.00	BI
ATOM 1736	H GLY 252	17.750	24.160	14.910	1.00	0.00	BI	ATOM 1772	CA GLY 256	19.277	21.273	21.890	1.00	46.68	BI
ATOM 1737	CA GLY 252	18.734	23.711	16.719	1.00	46.68	BI	ATOM 1773	C GLY 256	20.669	21.866	21.970	1.00	47.28	BI
ATOM 1738	C GLY 252	18.071	23.596	18.067	1.00	49.18	BI	ATOM 1774	O GLY 256	21.273	21.844	23.056	1.00	49.64	BI
ATOM 1739	O GLY 252	18.709	23.318	19.077	1.00	49.23	BI	ATOM 1775	N ILE 257	21.143	22.441	20.849	1.00	45.74	BI
ATOM 1740	N HIS 253	16.756	23.787	18.046	1.00	53.74	BI	ATOM 1776	H ILE 257	20.497	22.589	20.128	1.00	0.00	BI
ATOM 1741	H HIS 253	16.358	24.055	17.190	1.00	0.00	BI	ATOM 1777	CA ILE 257	22.481	23.017	20.726	1.00	43.64	BI
ATOM 1742	CA HIS 253	15.859	23.649	19.197	1.00	57.46	BI	ATOM 1778	CB ILE 257	22.684	23.363	19.257	1.00	42.54	BI
ATOM 1743	CB HIS 253	14.468	24.157	18.764	1.00	62.93	BI	ATOM 1779	CG2 ILE 257	23.988	24.110	19.073	1.00	41.05	BI
ATOM 1744	CG HIS 253	13.212	23.813	19.577	1.00	68.75	BI	ATOM 1780	CG1 ILE 257	22.694	22.088	18.437	1.00	40.55	BI
ATOM 1745	CD2 HIS 253	12.031	24.529	19.414	1.00	71.00	BI	ATOM 1781	CD ILE 257	22.452	22.468	16.970	1.00	39.49	BI
ATOM 1746	ND1 HIS 253	12.980	22.854	20.479	1.00	70.67	BI	ATOM 1782	C ILE 257	22.559	24.246	21.616	1.00	43.27	BI
ATOM 1747	HD1 HIS 253	13.627	22.193	20.830	1.00	0.00	BI	ATOM 1783	O ILE 257	21.706	25.110	21.450	1.00	43.22	BI
ATOM 1748	CE1 HIS 253	11.723	22.966	20.845	1.00	73.40	BI	ATOM 1784	N PRO 258	23.441	24.392	22.608	1.00	43.05	BI
ATOM 1749	NE2 HIS 253	11.156	23.973	20.204	1.00	72.91	BI	ATOM 1785	CD PRO 258	24.133	23.321	23.296	1.00	43.29	BI
ATOM 1750	HE2 HIS 253	10.218	24.260	20.311	1.00	0.00	BI	ATOM 1786	CA PRO 258	23.559	25.616	23.360	1.00	43.82	BI
ATOM 1751	C HIS 253	15.771	22.209	19.691	1.00	56.06	BI	ATOM 1787	CB PRO 258	24.295	25.236	24.612	1.00	41.97	BI
ATOM 1752	O HIS 253	15.880	21.827	20.857	1.00	56.17	BI	ATOM 1788	CG PRO 258	25.107	24.064	24.186	1.00	43.79	BI
ATOM 1753	N SER 254	15.395	21.435	18.724	1.00	53.46	BI	ATOM 1789	C PRO 258	24.252	26.703	22.555	1.00	46.06	BI
ATOM 1754	H SER 254	15.278	21.783	17.813	1.00	0.00	BI	ATOM 1790	O PRO 258	24.983	26.513	21.560	1.00	46.59	BI
ATOM 1755	CA SER 254	15.177	20.034	18.898	1.00	52.61	BI	ATOM 1791	N TRP 259	23.996	27.887	23.106	1.00	46.75	BI
ATOM 1756	CB SER 254	14.613	19.595	17.576	1.00	53.04	BI	ATOM 1792	H TRP 259	23.588	27.921	23.994	1.00	0.00	BI
ATOM 1757	OG SER 254	13.793	20.686	17.158	1.00	56.04	BI	ATOM 1793	CA TRP 259	24.427	29.143	22.517	1.00	45.77	BI
ATOM 1758	HC SER 254	13.369	20.467	16.319	1.00	0.00	BI	ATOM 1794	CB TRP 259	23.213	30.071	22.397	1.00	46.60	BI
ATOM 1759	C SER 254	16.512	19.386	19.275	1.00	51.48	BI	ATOM 1795	CG TRP 259	23.556	31.372	21.749	1.00	47.51	BI
ATOM 1760	O SER 254	16.596	18.639	20.245	1.00	51.90	BI	ATOM 1796	CD2 TRP 259	23.860	31.525	20.430	1.00	47.83	BI
ATOM 1761	N LEU 255	17.577	19.790	18.562	1.00	49.31	BI	ATOM 1797	CE2 TRP 259	24.154	32.888	20.392	1.00	48.47	BI
ATOM 1762	H LEU 255	17.430	20.480	17.889	1.00	0.00	BI	ATOM 1798	CE3 TRP 259	23.940	30.745	19.290	1.00	47.39	BI

FIG. 5Z

ATOM 1799	CDI TRP 259	23.639	32.520	22.493	1.00	48.60	ATOM 1835	C SER 263	27.909	41.354	22.600	1.00	56.15	B1
ATOM 1800	NEI TRP 259	24.013	33.421	21.628	1.00	48.27	ATOM 1836	O SER 263	28.744	42.243	22.753	1.00	57.88	B1
ATOM 1801	HEI TRP 259	24.224	34.344	21.870	1.00	0.00	ATOM 1837	N SER 264	26.899	41.231	23.452	1.00	56.52	B1
ATOM 1802	CZ2 TRP 259	24.531	33.486	19.195	1.00	47.40	ATOM 1838	H SER 264	26.277	40.478	23.415	1.00	0.00	B1
ATOM 1803	CZ3 TRP 259	24.317	31.344	18.097	1.00	49.07	ATOM 1839	CA SER 264	26.716	42.204	24.494	1.00	58.28	B1
ATOM 1804	CH2 TRP 259	24.613	32.706	18.050	1.00	49.12	ATOM 1840	CB SER 264	25.313	41.977	25.064	1.00	58.77	B1
ATOM 1805	C TRP 259	25.459	29.727	23.440	1.00	44.01	ATOM 1841	OG SER 264	25.099	40.726	25.713	1.00	58.50	B1
ATOM 1806	O TRP 259	25.340	29.664	24.671	1.00	43.25	ATOM 1842	HG SER 264	25.385	40.832	26.632	1.00	0.00	B1
ATOM 1807	N ALA 260	26.469	30.247	22.777	1.00	43.01	ATOM 1843	C SER 264	27.800	42.168	25.584	1.00	59.95	B1
ATOM 1808	H ALA 260	26.523	30.198	21.796	1.00	43.00	ATOM 1844	O SER 264	27.610	42.805	26.620	1.00	60.44	B1
ATOM 1809	CA ALA 260	27.493	30.973	23.482	1.00	43.48	ATOM 1845	N CYS 265	28.948	41.484	25.466	1.00	61.37	B1
ATOM 1810	CB ALA 260	28.874	30.549	22.969	1.00	43.33	ATOM 1846	H CYS 265	29.192	41.114	24.596	1.00	0.00	B1
ATOM 1811	C ALA 260	27.249	32.486	23.216	1.00	43.41	ATOM 1847	CA CYS 265	29.958	41.502	26.509	1.00	62.57	B1
ATOM 1812	O ALA 260	27.315	32.946	22.054	1.00	40.55	ATOM 1848	CB CYS 265	30.991	40.418	26.285	1.00	64.32	B1
ATOM 1813	N PRO 261	26.853	33.267	24.253	1.00	42.61	ATOM 1849	SG CYS 265	32.322	40.638	27.504	1.00	71.40	B1
ATOM 1814	CD PRO 261	26.527	32.807	25.606	1.00	42.33	ATOM 1850	C CYS 265	30.667	42.860	26.515	1.00	63.12	B1
ATOM 1815	CA PRO 261	26.720	34.701	24.199	1.00	42.37	ATOM 1851	OTI CYS 265	31.065	43.360	25.444	1.00	63.44	B1
ATOM 1816	CB PRO 261	25.778	34.987	25.335	1.00	41.46	ATOM 1852	OT2 CYS 265	30.809	43.408	27.610	1.00	61.72	B1
ATOM 1817	CG PRO 261	26.251	34.060	26.411	1.00	40.00	ATOM 1853	CB ALA 272	40.020	43.327	30.788	1.00	77.44	B2
ATOM 1818	C PRO 261	28.087	35.369	24.311	1.00	42.22	ATOM 1854	C ALA 272	38.698	41.201	30.601	1.00	76.53	B2
ATOM 1819	O PRO 261	28.988	34.956	25.037	1.00	38.82	ATOM 1855	O ALA 272	37.525	40.873	30.361	1.00	76.81	B2
ATOM 1820	N LEU 262	28.234	36.403	23.486	1.00	45.20	ATOM 1856	HT1 ALA 272	37.486	43.550	30.261	1.00	0.00	B2
ATOM 1821	H LEU 262	27.513	36.610	22.853	1.00	0.00	ATOM 1857	HT2 ALA 272	37.357	42.450	28.996	1.00	0.00	B2
ATOM 1822	CA LEU 262	29.434	37.210	23.498	1.00	46.50	ATOM 1858	N ALA 272	37.973	43.169	29.427	1.00	76.81	B2
ATOM 1823	CB LEU 262	30.531	36.609	22.610	1.00	45.09	ATOM 1859	HT3 ALA 272	38.195	43.924	28.752	1.00	0.00	B2
ATOM 1824	CG LEU 262	31.903	37.157	22.964	1.00	42.55	ATOM 1860	CA ALA 272	39.176	42.460	29.853	1.00	77.02	B2
ATOM 1825	CD1 LEU 262	32.344	36.695	24.338	1.00	41.52	ATOM 1861	N ALA 273	39.485	40.547	31.487	1.00	74.93	B2
ATOM 1826	CD2 LEU 262	32.850	36.730	21.900	1.00	44.21	ATOM 1862	H ALA 273	40.334	40.963	31.745	1.00	0.00	B2
ATOM 1827	C LEU 262	29.154	38.628	23.035	1.00	48.56	ATOM 1863	CA ALA 273	39.244	39.241	32.119	1.00	72.64	B2
ATOM 1828	O LEU 262	29.633	39.470	23.790	1.00	48.23	ATOM 1864	CB ALA 273	39.704	39.279	33.558	1.00	71.92	B2
ATOM 1829	N SER 263	28.388	38.956	21.960	1.00	51.33	ATOM 1865	C ALA 273	37.872	38.599	32.118	1.00	71.60	B2
ATOM 1830	H SER 263	27.982	38.242	21.427	1.00	0.00	ATOM 1866	O ALA 273	37.806	37.458	31.702	1.00	71.68	B2
ATOM 1831	CA SER 263	28.127	40.339	21.494	1.00	55.19	ATOM 1867	N GLY 274	36.775	39.282	32.484	1.00	70.20	B2
ATOM 1832	CB SER 263	26.871	40.511	20.612	1.00	57.17	ATOM 1868	H GLY 274	36.903	40.167	32.874	1.00	0.00	B2
ATOM 1833	OG SER 263	26.498	39.411	19.776	1.00	64.12	ATOM 1869	CA GLY 274	35.412	38.758	32.425	1.00	66.78	B2
ATOM 1834	HG SER 263	26.093	38.741	20.336	1.00	0.00	ATOM 1870	C GLY 274	35.050	38.437	30.990	1.00	65.05	B2

FIG. 5AA

ATOM	1871	O	GLY	274	34.627	37.320	30.709	1.00	66.44	B2	ATOM	1907	H	LEU	279	35.328	35.227	26.767	1.00	0.00	B2
ATOM	1872	N	CYS	275	35.301	39.364	30.048	1.00	62.77	B2	ATOM	1908	CA	LEU	279	35.398	33.966	25.069	1.00	42.80	B2
ATOM	1873	H	CYS	275	35.634	40.223	30.357	1.00	0.00	B2	ATOM	1909	CB	LEU	279	36.583	34.790	24.626	1.00	41.42	B2
ATOM	1874	CA	CYS	275	35.026	39.188	28.611	1.00	59.30	B2	ATOM	1910	CG	LEU	279	36.885	35.014	23.190	1.00	40.76	B2
ATOM	1875	C	CYS	275	35.875	38.063	28.054	1.00	55.89	B2	ATOM	1911	CD1	LEU	279	38.239	35.647	23.130	1.00	41.76	B2
ATOM	1876	O	CYS	275	35.425	37.152	27.351	1.00	54.41	B2	ATOM	1912	CD2	LEU	279	36.943	33.753	22.411	1.00	40.01	B2
ATOM	1877	CB	CYS	275	35.349	40.466	27.827	1.00	61.50	B2	ATOM	1913	C	LEU	279	35.876	32.554	25.341	1.00	42.92	B2
ATOM	1878	SG	CYS	275	34.119	40.937	26.577	1.00	66.63	B2	ATOM	1914	O	LEU	279	35.572	31.598	24.640	1.00	42.57	B2
ATOM	1879	N	LEU	276	37.124	38.114	28.506	1.00	52.23	B2	ATOM	1915	N	HIS	280	36.654	32.463	26.403	1.00	43.93	B2
ATOM	1880	H	LEU	276	37.350	38.722	29.233	1.00	0.00	B2	ATOM	1916	H	HIS	280	36.837	33.282	26.917	1.00	0.00	B2
ATOM	1881	CA	LEU	276	38.091	37.163	28.066	1.00	48.93	B2	ATOM	1917	CA	HIS	280	37.215	31.223	26.850	1.00	46.12	B2
ATOM	1882	CB	LEU	276	39.483	37.564	28.542	1.00	45.96	B2	ATOM	1918	CB	HIS	280	38.029	31.506	28.101	1.00	48.74	B2
ATOM	1883	CG	LEU	276	40.241	38.557	27.670	1.00	43.20	B2	ATOM	1919	CG	HIS	280	38.914	30.320	28.394	1.00	54.16	B2
ATOM	1884	CD1	LEU	276	41.599	38.782	28.279	1.00	44.63	B2	ATOM	1920	CD2	HIS	280	40.041	30.069	27.650	1.00	56.02	B2
ATOM	1885	CD2	LEU	276	40.429	38.033	26.271	1.00	40.55	B2	ATOM	1921	ND1	HIS	280	38.759	29.326	29.264	1.00	56.01	B2
ATOM	1886	C	LEU	276	37.673	35.833	28.638	1.00	47.84	B2	ATOM	1922	HD1	HIS	280	38.012	29.203	29.890	1.00	0.00	B2
ATOM	1887	O	LEU	276	37.784	34.803	27.964	1.00	48.51	B2	ATOM	1923	CE1	HIS	280	39.744	28.483	29.058	1.00	56.64	B2
ATOM	1888	N	ALA	277	37.074	35.840	29.804	1.00	45.56	B2	ATOM	1924	NE2	HIS	280	40.507	28.937	28.088	1.00	56.64	B2
ATOM	1889	H	ALA	277	36.898	36.662	30.289	1.00	0.00	B2	ATOM	1925	HE2	HIS	280	41.282	28.478	27.684	1.00	0.00	B2
ATOM	1890	CA	ALA	277	36.613	34.605	30.365	1.00	45.77	B2	ATOM	1926	C	HIS	280	36.161	30.134	27.117	1.00	45.65	B2
ATOM	1891	CB	ALA	277	36.147	34.810	31.783	1.00	47.87	B2	ATOM	1927	O	HIS	280	36.362	28.977	26.711	1.00	46.23	B2
ATOM	1892	C	ALA	277	35.442	34.111	29.542	1.00	45.03	B2	ATOM	1928	N	SER	281	35.086	30.473	27.822	1.00	43.91	B2
ATOM	1893	O	ALA	277	35.342	32.926	29.271	1.00	44.20	B2	ATOM	1929	H	SER	281	35.009	31.367	28.219	1.00	0.00	B2
ATOM	1894	N	GLN	278	34.592	35.000	29.049	1.00	45.13	B2	ATOM	1930	CA	SER	281	34.008	29.574	28.105	1.00	43.53	B2
ATOM	1895	H	GLN	278	34.731	35.944	29.263	1.00	0.00	B2	ATOM	1931	CB	SER	281	33.026	30.291	29.002	1.00	44.18	B2
ATOM	1896	CA	GLN	278	33.435	34.601	28.284	1.00	45.27	B2	ATOM	1932	OG	SER	281	33.761	30.812	30.113	1.00	47.79	B2
ATOM	1897	CB	GLN	278	32.550	35.825	28.083	1.00	48.13	B2	ATOM	1933	HG	SER	281	33.288	30.648	30.931	1.00	0.00	B2
ATOM	1898	CG	GLN	278	31.140	35.442	28.484	1.00	56.00	B2	ATOM	1934	C	SER	281	33.382	29.169	26.787	1.00	43.35	B2
ATOM	1899	CD	GLN	278	30.045	36.464	28.178	1.00	61.94	B2	ATOM	1935	O	SER	281	33.334	27.973	26.496	1.00	44.83	B2
ATOM	1900	OE1	GLN	278	29.048	36.530	28.896	1.00	65.95	B2	ATOM	1936	N	GLY	282	32.977	30.120	25.940	1.00	42.33	B2
ATOM	1901	NE2	GLN	278	30.080	37.291	27.132	1.00	65.55	B2	ATOM	1937	H	GLY	282	33.043	31.058	26.221	1.00	0.00	B2
ATOM	1902	HE21	GLN	278	30.829	37.221	26.510	1.00	0.00	B2	ATOM	1938	CA	GLY	282	32.363	29.869	24.632	1.00	40.65	B2
ATOM	1903	HE22	GLN	278	29.343	37.927	27.056	1.00	0.00	B2	ATOM	1939	C	GLY	282	33.175	28.937	23.755	1.00	39.06	B2
ATOM	1904	C	GLN	278	33.812	33.971	26.950	1.00	43.16	B2	ATOM	1940	O	GLY	282	32.584	28.075	23.107	1.00	40.10	B2
ATOM	1905	O	GLN	278	33.173	33.050	26.462	1.00	40.58	B2	ATOM	1941	N	LEU	283	34.514	29.066	23.776	1.00	37.39	B2
ATOM	1906	N	LEU	279	34.869	34.476	26.331	1.00	43.32	B2	ATOM	1942	H	LEU	283	34.880	29.807	24.304	1.00	0.00	B2

FIG. 5BB

ATOM 1943	CA LEU	283	35.465	28.213	23.037	1.00	35.06	B2	ATOM 1979	CE2 TYR	286	29.707	26.990	18.521	1.00	37.55	B2
ATOM 1944	CB LEU	283	36.902	28.718	23.089	1.00	30.20	B2	ATOM 1980	CZ TYR	286	29.449	28.164	19.178	1.00	37.73	B2
ATOM 1945	CG LEU	283	37.167	30.001	22.302	1.00	25.73	B2	ATOM 1981	OH TYR	286	28.285	28.826	18.823	1.00	38.04	B2
ATOM 1946	CD1 LEU	283	38.539	30.461	22.664	1.00	24.38	B2	ATOM 1982	HH TYR	286	28.289	29.707	19.243	1.00	0.00	B2
ATOM 1947	CD2 LEU	283	37.036	29.802	20.815	1.00	21.94	B2	ATOM 1983	C TYR	286	33.393	23.464	20.926	1.00	34.80	B2
ATOM 1948	C LEU	283	35.470	26.851	23.651	1.00	34.81	B2	ATOM 1984	O TYR	286	33.071	22.537	20.180	1.00	35.35	B2
ATOM 1949	O LEU	283	35.314	25.859	22.947	1.00	31.09	B2	ATOM 1985	N ALA	287	34.527	23.339	21.636	1.00	34.66	B2
ATOM 1950	N PHE	284	35.533	26.842	24.973	1.00	37.62	B2	ATOM 1986	H ALA	287	34.803	24.088	22.206	1.00	0.00	B2
ATOM 1951	H PHE	284	35.567	27.686	25.467	1.00	0.00	B2	ATOM 1987	CA ALA	287	35.350	22.108	21.565	1.00	34.28	B2
ATOM 1952	CA PHE	284	35.485	25.596	25.710	1.00	42.51	B2	ATOM 1988	CB ALA	287	36.617	22.291	22.415	1.00	33.63	B2
ATOM 1953	CB PHE	284	35.542	25.877	27.184	1.00	49.49	B2	ATOM 1989	C ALA	287	34.528	20.906	22.073	1.00	33.32	B2
ATOM 1954	CG PHE	284	36.221	24.770	27.968	1.00	58.39	B2	ATOM 1990	O ALA	287	34.535	19.827	21.478	1.00	33.07	B2
ATOM 1955	CD1 PHE	284	37.265	25.108	28.816	1.00	63.05	B2	ATOM 1991	N GLY	288	33.723	21.118	23.111	1.00	33.19	B2
ATOM 1956	CD2 PHE	284	35.810	23.453	27.861	1.00	60.84	B2	ATOM 1992	H GLY	288	33.791	21.985	23.564	1.00	0.00	B2
ATOM 1957	CE1 PHE	284	37.900	24.124	29.563	1.00	65.86	B2	ATOM 1993	CA GLY	288	33.761	20.162	23.655	1.00	35.62	B2
ATOM 1958	CE2 PHE	284	36.444	22.480	28.605	1.00	64.49	B2	ATOM 1994	C GLY	288	31.744	19.606	22.636	1.00	36.89	B2
ATOM 1959	CZ PHE	284	37.486	22.810	29.455	1.00	66.32	B2	ATOM 1995	O GLY	288	31.624	18.379	22.444	1.00	34.97	B2
ATOM 1960	C PHE	284	34.204	24.849	25.384	1.00	41.44	B2	ATOM 1996	N LEU	289	31.037	20.536	21.966	1.00	36.69	B2
ATOM 1961	O PHE	284	34.257	23.630	25.306	1.00	41.42	B2	ATOM 1997	H LEU	289	31.200	21.476	22.201	1.00	0.00	B2
ATOM 1962	N LEU	285	33.100	25.563	25.101	1.00	41.24	B2	ATOM 1998	CA LEU	289	30.018	20.249	20.954	1.00	35.05	B2
ATOM 1963	H LEU	285	33.192	26.534	25.174	1.00	0.00	B2	ATOM 1999	CB LEU	289	29.351	21.576	20.502	1.00	36.32	B2
ATOM 1964	CA LEU	285	31.781	25.025	24.730	1.00	38.92	B2	ATOM 2000	CG LEU	289	28.552	22.450	21.464	1.00	35.76	B2
ATOM 1965	CB LEU	285	30.727	26.139	24.807	1.00	39.05	B2	ATOM 2001	CD1 LEU	289	28.256	23.821	20.890	1.00	32.66	B2
ATOM 1966	CG LEU	285	29.292	25.740	24.481	1.00	41.16	B2	ATOM 2002	CD2 LEU	289	27.246	21.780	21.697	1.00	35.35	B2
ATOM 1967	CD1 LEU	285	28.711	24.981	25.662	1.00	41.12	B2	ATOM 2003	C LEU	289	30.536	19.519	19.714	1.00	34.21	B2
ATOM 1968	CD2 LEU	285	28.472	26.971	24.139	1.00	39.60	B2	ATOM 2004	O LEU	289	29.871	18.694	19.078	1.00	33.28	B2
ATOM 1969	C LEU	285	31.780	24.441	23.329	1.00	37.34	B2	ATOM 2005	N LEU	290	31.756	19.902	19.355	1.00	33.25	B2
ATOM 1970	O LEU	285	31.245	23.351	23.095	1.00	36.97	B2	ATOM 2006	H LEU	290	32.183	20.634	19.850	1.00	0.00	B2
ATOM 1971	N TYR	286	32.352	25.172	22.372	1.00	35.26	B2	ATOM 2007	CA LEU	290	32.448	19.345	18.230	1.00	32.44	B2
ATOM 1972	H TYR	286	32.705	26.062	22.593	1.00	0.00	B2	ATOM 2008	CB LEU	290	33.729	20.159	18.000	1.00	32.62	B2
ATOM 1973	CA TYR	286	32.455	24.660	21.033	1.00	35.04	B2	ATOM 2009	CG LEU	290	33.560	21.509	17.315	1.00	32.05	B2
ATOM 1974	CB TYR	286	32.891	25.790	20.122	1.00	34.44	B2	ATOM 2010	CD1 LEU	290	34.889	22.189	17.349	1.00	32.58	B2
ATOM 1975	CG TYR	286	31.690	26.684	19.808	1.00	34.75	B2	ATOM 2011	CD2 LEU	290	33.068	21.374	15.879	1.00	31.74	B2
ATOM 1976	CD1 TYR	286	31.433	27.879	20.469	1.00	35.67	B2	ATOM 2012	C LEU	290	32.737	17.908	18.558	1.00	31.94	B2
ATOM 1977	CE1 TYR	286	30.313	28.620	20.158	1.00	36.90	B2	ATOM 2013	O LEU	290	32.432	17.020	17.772	1.00	30.50	B2
ATOM 1978	CD2 TYR	286	30.823	26.255	18.839	1.00	36.19	B2	ATOM 2014	N GLN	291	33.249	17.711	19.770	1.00	33.58	B2

FIG. 5CC

ATOM 2015	H	GLN	291	33.512	18.494	20.298	1.00	0.00	B2	ATOM 2051	N	GLY	295	32.424	13.203	15.106	1.00	40.93	B2
ATOM 2016	CA	GLN	291	33.499	16.372	20.311	1.00	36.39	B2	ATOM 2052	H	GLY	295	32.357	14.033	15.621	1.00	0.00	B2
ATOM 2017	CB	GLN	291	33.988	16.490	21.702	1.00	36.86	B2	ATOM 2053	CA	GLY	295	32.998	13.236	13.783	1.00	39.95	B2
ATOM 2018	CG	GLN	291	34.926	15.367	21.950	1.00	39.48	B2	ATOM 2054	C	GLY	295	32.027	13.230	12.634	1.00	40.60	B2
ATOM 2019	CD	GLN	291	35.658	15.503	23.252	1.00	40.79	B2	ATOM 2055	O	GLY	295	32.477	13.216	11.487	1.00	40.96	B2
ATOM 2020	OE1	GLN	291	36.457	14.626	23.549	1.00	44.80	B2	ATOM 2056	N	ILE	296	30.728	13.296	12.898	1.00	41.18	B2
ATOM 2021	NE2	GLN	291	35.494	16.535	24.072	1.00	42.59	B2	ATOM 2057	H	ILE	296	30.446	13.210	13.825	1.00	0.00	B2
ATOM 2022	HE21	GLN	291	34.928	17.287	23.817	1.00	0.00	B2	ATOM 2058	CA	ILE	296	29.687	13.306	11.888	1.00	44.02	B2
ATOM 2023	HE22	GLN	291	35.910	16.463	24.958	1.00	0.00	B2	ATOM 2059	CB	ILE	296	29.683	14.580	11.009	1.00	43.49	B2
ATOM 2024	C	GLN	291	32.233	15.536	20.307	1.00	36.66	B2	ATOM 2060	CG2	ILE	296	28.288	14.685	10.421	1.00	40.56	B2
ATOM 2025	O	GLN	291	32.220	14.478	19.707	1.00	37.46	B2	ATOM 2061	CG1	ILE	296	30.047	15.831	11.793	1.00	45.11	B2
ATOM 2026	N	ALA	292	31.143	16.023	20.913	1.00	38.37	B2	ATOM 2062	CD	ILE	296	30.039	17.189	11.062	1.00	46.06	B2
ATOM 2027	H	ALA	292	31.255	16.849	21.418	1.00	0.00	B2	ATOM 2063	C	ILE	296	29.820	12.107	10.949	1.00	46.71	B2
ATOM 2028	CA	ALA	292	29.778	15.451	20.857	1.00	39.25	B2	ATOM 2064	O	ILE	296	28.918	11.279	11.060	1.00	50.61	B2
ATOM 2029	CB	ALA	292	28.818	16.485	21.444	1.00	40.28	B2	ATOM 2065	N	SER	297	30.767	11.875	10.019	1.00	47.21	B2
ATOM 2030	C	ALA	292	29.215	14.999	19.484	1.00	38.65	B2	ATOM 2066	H	SER	297	31.526	12.491	9.936	1.00	0.00	B2
ATOM 2031	O	ALA	292	28.411	14.067	19.356	1.00	37.58	B2	ATOM 2067	CA	SER	297	30.810	10.646	9.234	1.00	46.73	B2
ATOM 2032	N	LEU	293	29.614	15.702	18.430	1.00	39.00	B2	ATOM 2068	CB	SER	297	30.239	10.884	7.865	1.00	45.48	B2
ATOM 2033	H	LEU	293	30.149	16.513	18.574	1.00	0.00	B2	ATOM 2069	CG	SER	297	30.988	11.782	7.072	1.00	46.27	B2
ATOM 2034	CA	LEU	293	29.265	15.335	17.077	1.00	39.74	B2	ATOM 2070	HG	SER	297	30.321	12.200	6.503	1.00	0.00	B2
ATOM 2035	CB	LEU	293	29.662	16.418	16.106	1.00	37.53	B2	ATOM 2071	C	SER	297	32.263	10.269	9.123	1.00	48.72	B2
ATOM 2036	CG	LEU	293	28.969	17.701	16.138	1.00	34.34	B2	ATOM 2072	O	SER	297	33.120	11.122	9.391	1.00	50.55	B2
ATOM 2037	CD1	LEU	293	29.547	18.582	15.053	1.00	33.88	B2	ATOM 2073	N	PRO	298	32.655	9.069	8.697	1.00	49.68	B2
ATOM 2038	CD2	LEU	293	27.503	17.462	15.918	1.00	35.69	B2	ATOM 2074	CD	PRO	298	31.782	7.964	8.334	1.00	50.62	B2
ATOM 2039	C	LEU	293	29.933	14.060	16.596	1.00	40.86	B2	ATOM 2075	CA	PRO	298	34.049	8.701	8.458	1.00	50.33	B2
ATOM 2040	O	LEU	293	29.686	13.669	15.449	1.00	40.58	B2	ATOM 2076	CB	PRO	298	33.948	7.308	7.856	1.00	51.53	B2
ATOM 2041	N	GLU	294	30.887	13.495	17.365	1.00	42.12	B2	ATOM 2077	CG	PRO	298	32.576	7.266	7.231	1.00	50.43	B2
ATOM 2042	H	GLU	294	31.131	13.963	18.190	1.00	0.00	B2	ATOM 2078	C	PRO	298	34.795	9.692	7.579	1.00	50.08	B2
ATOM 2043	CA	GLU	294	31.598	12.253	17.076	1.00	42.89	B2	ATOM 2079	O	PRO	298	35.883	10.137	7.930	1.00	50.50	B2
ATOM 2044	CB	GLU	294	30.806	10.984	17.485	1.00	48.38	B2	ATOM 2080	N	GLN	299	34.173	10.086	6.469	1.00	50.48	B2
ATOM 2045	CG	GLU	294	30.715	10.614	18.972	1.00	56.26	B2	ATOM 2081	H	GLN	299	33.279	9.729	6.296	1.00	0.00	B2
ATOM 2046	CD	GLU	294	29.271	10.408	19.486	1.00	63.70	B2	ATOM 2082	CA	GLN	299	34.749	11.050	5.550	1.00	51.74	B2
ATOM 2047	OE1	GLU	294	29.058	10.603	20.702	1.00	67.72	B2	ATOM 2083	CB	GLN	299	33.898	11.236	4.301	1.00	54.33	B2
ATOM 2048	OE2	GLU	294	28.363	10.074	18.692	1.00	64.81	B2	ATOM 2084	CG	GLN	299	33.095	10.067	3.725	1.00	58.11	B2
ATOM 2049	C	GLU	294	31.972	12.068	15.632	1.00	41.53	B2	ATOM 2085	CD	GLN	299	31.658	10.086	4.259	1.00	61.49	B2
ATOM 2050	O	GLU	294	31.804	11.007	15.021	1.00	40.29	B2	ATOM 2086	OE1	GLN	299	31.160	9.083	4.776	1.00	61.00	B2

FIG. 5DD

ATOM 2087	NE2 GLN	299	30.942	11.217	4.204	1.00	62.12	B2	ATOM 2123	H LEU	304	36.672	16.500	10.762	1.00	0.00	B2
ATOM 2088	HE21 GLN	299	31.345	12.012	3.800	1.00	0.00	B2	ATOM 2124	CA LEU	304	36.436	17.746	12.418	1.00	31.01	B2
ATOM 2089	HE22 GLN	299	30.034	11.191	4.566	1.00	0.00	B2	ATOM 2125	CB LEU	304	35.345	16.803	12.708	1.00	30.31	B2
ATOM 2090	C GLN	299	34.923	12.453	6.160	1.00	51.04	B2	ATOM 2126	CG LEU	304	34.234	17.567	13.320	1.00	31.32	B2
ATOM 2091	O GLN	299	35.796	13.186	5.718	1.00	53.38	B2	ATOM 2127	CD1 LEU	304	33.121	17.626	12.309	1.00	28.87	B2
ATOM 2092	N LEU	300	34.118	12.918	7.120	1.00	48.15	B2	ATOM 2128	CD2 LEU	304	33.921	16.970	14.692	1.00	34.23	B2
ATOM 2093	H LEU	300	33.383	12.351	7.437	1.00	0.00	B2	ATOM 2129	C LEU	304	37.553	17.776	13.421	1.00	31.86	B2
ATOM 2094	CA LEU	300	34.272	14.220	7.745	1.00	43.32	B2	ATOM 2130	O LEU	304	37.615	18.623	14.259	1.00	34.21	B2
ATOM 2095	CB LEU	300	32.856	14.719	8.021	1.00	41.39	B2	ATOM 2131	N ASP	305	38.510	16.811	13.326	1.00	30.56	B2
ATOM 2096	CG LEU	300	32.073	15.546	6.974	1.00	37.99	B2	ATOM 2132	H ASP	305	38.456	16.117	12.635	1.00	0.00	B2
ATOM 2097	CD1 LEU	300	31.872	14.824	5.688	1.00	38.34	B2	ATOM 2133	CA ASP	305	39.576	16.797	14.303	1.00	30.72	B2
ATOM 2098	CD2 LEU	300	30.705	15.809	7.522	1.00	37.67	B2	ATOM 2134	CB ASP	305	40.504	15.608	14.114	1.00	36.20	B2
ATOM 2099	C LEU	300	35.142	14.220	9.019	1.00	42.84	B2	ATOM 2135	CG ASP	305	39.912	14.201	14.288	1.00	40.64	B2
ATOM 2100	O LEU	300	35.558	15.278	9.541	1.00	41.56	B2	ATOM 2136	OD1 ASP	305	38.976	14.040	15.103	1.00	37.52	B2
ATOM 2101	N GLY	301	35.467	13.016	9.528	1.00	40.83	B2	ATOM 2137	OD2 ASP	305	40.426	13.304	13.581	1.00	42.39	B2
ATOM 2102	H GLY	301	35.157	12.221	9.046	1.00	0.00	B2	ATOM 2138	C ASP	305	40.435	18.034	14.238	1.00	27.56	B2
ATOM 2103	CA GLY	301	36.199	12.826	10.779	1.00	38.72	B2	ATOM 2139	O ASP	305	40.775	18.575	15.311	1.00	24.61	B2
ATOM 2104	C GLY	301	37.500	13.607	10.887	1.00	37.69	B2	ATOM 2140	N THR	306	40.781	18.417	12.979	1.00	24.77	B2
ATOM 2105	O GLY	301	37.665	14.406	11.809	1.00	37.31	B2	ATOM 2141	H THR	306	40.469	17.875	12.230	1.00	0.00	B2
ATOM 2106	N PRO	302	38.468	13.452	9.985	1.00	37.33	B2	ATOM 2142	CA THR	306	41.553	19.633	12.751	1.00	24.39	B2
ATOM 2107	CD PRO	302	38.353	12.630	8.790	1.00	37.77	B2	ATOM 2143	CB THR	306	41.665	19.931	11.318	1.00	24.58	B2
ATOM 2108	CA PRO	302	39.676	14.281	9.884	1.00	37.60	B2	ATOM 2144	OG1 THR	306	42.074	18.753	10.665	1.00	25.13	B2
ATOM 2109	CB PRO	302	40.256	13.907	8.541	1.00	36.62	B2	ATOM 2145	HG1 THR	306	41.447	18.029	10.768	1.00	0.00	B2
ATOM 2110	CG PRO	302	39.047	13.487	7.745	1.00	37.94	B2	ATOM 2146	CG2 THR	306	42.690	21.027	11.089	1.00	25.77	B2
ATOM 2111	C PRO	302	39.486	15.782	10.033	1.00	37.45	B2	ATOM 2147	C THR	306	40.893	20.844	13.419	1.00	25.24	B2
ATOM 2112	O PRO	302	40.132	16.398	10.901	1.00	38.33	B2	ATOM 2148	O THR	306	41.488	21.472	14.296	1.00	27.24	B2
ATOM 2113	N THR	303	38.547	16.311	9.204	1.00	37.05	B2	ATOM 2149	N LEU	307	39.615	21.134	13.139	1.00	25.91	B2
ATOM 2114	H THR	303	38.085	15.727	8.567	1.00	0.00	B2	ATOM 2150	H LEU	307	39.125	20.547	12.520	1.00	0.00	B2
ATOM 2115	CA THR	303	38.119	17.705	9.128	1.00	35.81	B2	ATOM 2151	CA LEU	307	38.900	22.228	13.764	1.00	25.53	B2
ATOM 2116	CB THR	303	36.963	17.770	8.123	1.00	37.26	B2	ATOM 2152	CB LEU	307	37.571	22.170	13.142	1.00	25.09	B2
ATOM 2117	OG1 THR	303	37.416	17.161	6.909	1.00	39.64	B2	ATOM 2153	CG LEU	307	36.530	23.097	13.588	1.00	27.93	B2
ATOM 2118	HG1 THR	303	37.369	17.785	6.178	1.00	0.00	B2	ATOM 2154	CD1 LEU	307	37.008	24.515	13.484	1.00	29.87	B2
ATOM 2119	CG2 THR	303	36.469	19.204	7.927	1.00	38.55	B2	ATOM 2155	CD2 LEU	307	35.311	22.846	12.728	1.00	28.93	B2
ATOM 2120	C THR	303	37.687	18.223	10.506	1.00	34.93	B2	ATOM 2156	C LEU	307	38.850	22.214	15.269	1.00	27.09	B2
ATOM 2121	O THR	303	38.085	19.263	11.063	1.00	35.11	B2	ATOM 2157	O LEU	307	38.854	23.253	15.925	1.00	30.03	B2
ATOM 2122	N LEU	304	36.928	17.366	11.150	1.00	33.76	B2	ATOM 2158	N GLN	308	38.875	21.044	15.879	1.00	29.09	B2

FIG. 5EE

ATOM 2159	H	GLN	308	38.883	20.239	15.319	1.00	0.00	ATOM 2195	O	VAL	311	40.437	26.647	20.719	1.00	29.71	B2
ATOM 2160	CA	GLN	308	38.824	20.848	17.340	1.00	29.36	ATOM 2196	N	ALA	312	40.762	24.428	20.357	1.00	27.97	B2
ATOM 2161	CB	GLN	308	38.379	19.399	17.562	1.00	29.41	ATOM 2197	H	ALA	312	40.585	23.674	19.756	1.00	0.00	B2
ATOM 2162	CG	GLN	308	37.862	19.140	18.935	1.00	32.24	ATOM 2198	CA	ALA	312	41.515	24.157	21.583	1.00	29.24	B2
ATOM 2163	CD	GLN	308	37.586	17.672	19.165	1.00	34.03	ATOM 2199	CB	ALA	312	41.855	22.688	21.532	1.00	30.53	B2
ATOM 2164	OE1	GLN	308	36.973	17.023	18.311	1.00	33.48	ATOM 2200	C	ALA	312	42.778	25.026	21.784	1.00	30.06	B2
ATOM 2165	NE2	GLN	308	38.053	17.127	20.299	1.00	31.67	ATOM 2201	O	ALA	312	43.057	25.508	22.886	1.00	30.04	B2
ATOM 2166	HE21	GLN	308	38.547	17.697	20.917	1.00	0.00	ATOM 2202	N	ASP	313	43.554	25.286	20.735	1.00	31.33	B2
ATOM 2167	HE22	GLN	308	37.875	16.174	20.436	1.00	0.00	ATOM 2203	H	ASP	313	43.433	24.730	19.935	1.00	0.00	B2
ATOM 2168	C	GLN	308	40.154	21.138	18.051	1.00	28.94	ATOM 2204	CA	ASP	313	44.610	26.275	20.743	1.00	34.22	B2
ATOM 2169	O	GLN	308	40.196	21.796	19.101	1.00	28.44	ATOM 2205	CB	ASP	313	45.279	26.512	19.447	1.00	38.87	B2
ATOM 2170	N	LEU	309	41.269	20.671	17.460	1.00	28.78	ATOM 2206	CG	ASP	313	46.071	25.404	18.866	1.00	44.55	B2
ATOM 2171	H	LEU	309	41.157	20.120	16.655	1.00	0.00	ATOM 2207	OD1	ASP	313	46.225	25.439	17.636	1.00	48.67	B2
ATOM 2172	CA	LEU	309	42.632	20.923	17.967	1.00	28.56	ATOM 2208	OD2	ASP	313	46.521	24.553	19.647	1.00	49.25	B2
ATOM 2173	CB	LEU	309	43.671	20.154	17.106	1.00	26.54	ATOM 2209	C	ASP	313	44.187	27.699	21.059	1.00	35.12	B2
ATOM 2174	CG	LEU	309	43.632	18.636	17.241	1.00	24.98	ATOM 2210	O	ASP	313	44.807	28.390	21.894	1.00	38.60	B2
ATOM 2175	CD1	LEU	309	44.595	17.935	16.353	1.00	24.17	ATOM 2211	N	PHE	314	43.192	28.216	20.339	1.00	33.36	B2
ATOM 2176	CD2	LEU	309	43.992	18.310	18.621	1.00	23.45	ATOM 2212	H	PHE	314	42.784	27.683	19.619	1.00	0.00	B2
ATOM 2177	C	LEU	309	42.893	22.416	17.909	1.00	28.24	ATOM 2213	CA	PHE	314	42.715	29.548	20.600	1.00	31.09	B2
ATOM 2178	O	LEU	309	43.370	22.957	18.907	1.00	30.32	ATOM 2214	CB	PHE	314	41.572	29.860	19.631	1.00	32.06	B2
ATOM 2179	N	ASP	310	42.548	23.027	16.749	1.00	26.58	ATOM 2215	CG	PHE	314	41.074	31.303	19.636	1.00	33.37	B2
ATOM 2180	H	ASP	310	42.296	22.437	16.007	1.00	0.00	ATOM 2216	CD1	PHE	314	39.780	31.568	19.247	1.00	31.81	B2
ATOM 2181	CA	ASP	310	42.495	24.477	16.495	1.00	27.90	ATOM 2217	CD2	PHE	314	41.907	32.354	20.021	1.00	35.65	B2
ATOM 2182	CB	ASP	310	42.025	24.659	15.076	1.00	28.41	ATOM 2218	CE1	PHE	314	39.318	32.857	19.240	1.00	29.15	B2
ATOM 2183	CG	ASP	310	43.162	24.556	14.096	1.00	31.84	ATOM 2219	CE2	PHE	314	41.455	33.648	20.017	1.00	32.48	B2
ATOM 2184	OD1	ASP	310	42.959	24.766	12.905	1.00	31.54	ATOM 2220	CZ	PHE	314	40.154	33.870	19.622	1.00	32.81	B2
ATOM 2185	OD2	ASP	310	44.297	24.314	14.514	1.00	37.32	ATOM 2221	C	PHE	314	42.282	29.601	22.057	1.00	29.90	B2
ATOM 2186	C	ASP	310	41.666	25.410	17.422	1.00	27.99	ATOM 2222	O	PHE	314	42.658	30.550	22.764	1.00	26.87	B2
ATOM 2187	O	ASP	310	42.219	26.429	17.876	1.00	27.23	ATOM 2223	N	ALA	315	41.686	28.532	22.584	1.00	29.29	B2
ATOM 2188	N	VAL	311	40.374	25.086	17.725	1.00	26.29	ATOM 2224	H	ALA	315	41.448	27.764	22.022	1.00	0.00	B2
ATOM 2189	H	VAL	311	39.961	24.347	17.225	1.00	0.00	ATOM 2225	CA	ALA	315	41.300	28.583	23.961	1.00	31.61	B2
ATOM 2190	CA	VAL	311	39.546	25.803	18.706	1.00	24.29	ATOM 2226	CB	ALA	315	40.632	27.358	24.451	1.00	32.23	B2
ATOM 2191	CB	VAL	311	38.098	25.217	18.869	1.00	21.47	ATOM 2227	C	ALA	315	42.482	28.751	24.836	1.00	34.41	B2
ATOM 2192	CG1	VAL	311	37.341	25.915	19.949	1.00	19.01	ATOM 2228	O	ALA	315	42.361	29.437	25.853	1.00	37.66	B2
ATOM 2193	CG2	VAL	311	37.261	25.488	17.667	1.00	18.56	ATOM 2229	N	THR	316	43.646	28.250	24.476	1.00	36.16	B2
ATOM 2194	C	VAL	311	40.270	25.638	20.020	1.00	27.21	ATOM 2230	H	THR	316	43.745	27.778	23.625	1.00	0.00	B2

FIG. 5FF

ATOM	2231	CA	THR	316	44.780	28.388	25.374	1.00	37.99	B2	ATOM	2267	CZ2	TRP	319	43.044	30.512	34.456	1.00	61.00	B2
ATOM	2232	CB	THR	316	45.795	27.255	25.156	1.00	41.16	B2	ATOM	2268	CZ3	TRP	319	41.022	30.967	33.210	1.00	61.58	B2
ATOM	2233	OG1	THR	316	45.049	26.081	25.521	1.00	45.50	B2	ATOM	2269	CH2	TRP	319	41.704	30.854	34.417	1.00	62.04	B2
ATOM	2234	HG1	THR	316	44.316	25.900	24.913	1.00	0.00	B2	ATOM	2270	C	TRP	319	45.398	32.136	29.456	1.00	47.85	B2
ATOM	2235	CG2	THR	316	47.152	27.415	25.888	1.00	40.31	B2	ATOM	2271	O	TRP	319	45.635	32.772	30.490	1.00	47.99	B2
ATOM	2236	C	THR	316	45.458	29.710	25.177	1.00	38.47	B2	ATOM	2272	N	GLN	320	46.339	31.915	28.550	1.00	48.63	B2
ATOM	2237	O	THR	316	45.903	30.189	26.217	1.00	39.63	B2	ATOM	2273	H	GLN	320	46.091	31.482	27.708	1.00	0.00	B2
ATOM	2238	N	THR	317	45.620	30.287	23.970	1.00	36.53	B2	ATOM	2274	CA	GLN	320	47.706	32.319	28.767	1.00	49.45	B2
ATOM	2239	H	THR	317	45.351	29.800	23.164	1.00	0.00	B2	ATOM	2275	CB	GLN	320	48.567	31.988	27.589	1.00	51.44	B2
ATOM	2240	CA	THR	317	46.092	31.657	23.844	1.00	37.07	B2	ATOM	2276	CG	GLN	320	48.828	30.494	27.444	1.00	55.03	B2
ATOM	2241	CB	THR	317	45.866	32.098	22.392	1.00	36.01	B2	ATOM	2277	CD	GLN	320	49.958	30.349	26.438	1.00	60.17	B2
ATOM	2242	OG1	THR	317	46.752	31.352	21.575	1.00	35.31	B2	ATOM	2278	OE1	GLN	320	51.116	30.465	26.834	1.00	65.26	B2
ATOM	2243	HG1	THR	317	46.489	30.441	21.389	1.00	0.00	B2	ATOM	2279	NE2	GLN	320	49.771	30.145	25.131	1.00	59.32	B2
ATOM	2244	CG2	THR	317	46.109	33.566	22.156	1.00	34.30	B2	ATOM	2280	HE21	GLN	320	48.859	30.087	24.789	1.00	0.00	B2
ATOM	2245	C	THR	317	45.338	32.597	24.832	1.00	39.30	B2	ATOM	2281	HE22	GLN	320	50.582	30.083	24.590	1.00	0.00	B2
ATOM	2246	O	THR	317	45.941	33.378	25.583	1.00	40.17	B2	ATOM	2282	C	GLN	320	47.717	33.790	28.983	1.00	49.62	B2
ATOM	2247	N	ILE	318	44.003	32.481	24.912	1.00	40.83	B2	ATOM	2283	O	GLN	320	48.251	34.209	29.987	1.00	49.91	B2
ATOM	2248	H	ILE	318	43.554	31.819	24.342	1.00	0.00	B2	ATOM	2284	N	GLN	321	46.998	34.538	28.150	1.00	51.76	B2
ATOM	2249	CA	ILE	318	43.172	33.317	25.788	1.00	40.75	B2	ATOM	2285	H	GLN	321	46.535	34.102	27.403	1.00	0.00	B2
ATOM	2250	CB	ILE	318	41.621	32.979	25.567	1.00	37.17	B2	ATOM	2286	CA	GLN	321	46.837	35.988	28.278	1.00	52.08	B2
ATOM	2251	CG2	ILE	318	40.742	33.706	26.545	1.00	34.29	B2	ATOM	2287	CB	GLN	321	46.015	36.571	27.151	1.00	49.72	B2
ATOM	2252	CG1	ILE	318	41.216	33.310	24.160	1.00	31.39	B2	ATOM	2288	CG	GLN	321	45.873	38.058	27.166	1.00	51.19	B2
ATOM	2253	CD	ILE	318	41.626	34.657	23.614	1.00	29.66	B2	ATOM	2289	CD	GLN	321	47.211	38.781	27.201	1.00	53.13	B2
ATOM	2254	C	ILE	318	43.624	33.019	27.217	1.00	42.43	B2	ATOM	2290	OE1	GLN	321	48.090	38.622	26.364	1.00	55.36	B2
ATOM	2255	O	ILE	318	44.064	33.963	27.856	1.00	42.54	B2	ATOM	2291	NE2	GLN	321	47.468	39.618	28.177	1.00	53.21	B2
ATOM	2256	N	TRP	319	43.662	31.784	27.744	1.00	44.17	B2	ATOM	2292	HE21	GLN	321	46.800	39.713	28.889	1.00	0.00	B2
ATOM	2257	H	TRP	319	43.537	31.008	27.163	1.00	0.00	B2	ATOM	2293	HE22	GLN	321	48.338	40.057	28.168	1.00	0.00	B2
ATOM	2258	CA	TRP	319	43.994	31.633	29.142	1.00	46.90	B2	ATOM	2294	C	GLN	321	46.112	36.315	29.562	1.00	53.30	B2
ATOM	2259	CB	TRP	319	43.892	30.179	29.597	1.00	50.64	B2	ATOM	2295	O	GLN	321	46.293	37.422	30.058	1.00	54.39	B2
ATOM	2260	CG	TRP	319	43.998	30.094	31.131	1.00	56.05	B2	ATOM	2296	N	MET	322	45.269	35.441	30.117	1.00	54.50	B2
ATOM	2261	CD2	TRP	319	43.005	30.397	32.038	1.00	58.61	B2	ATOM	2297	H	MET	322	45.098	34.592	29.662	1.00	0.00	B2
ATOM	2262	CE2	TRP	319	43.685	30.281	33.251	1.00	60.50	B2	ATOM	2298	CA	MET	322	44.619	35.748	31.375	1.00	55.42	B2
ATOM	2263	CE3	TRP	319	41.668	30.740	32.005	1.00	60.12	B2	ATOM	2299	CB	MET	322	43.595	34.690	31.713	1.00	52.93	B2
ATOM	2264	CD1	TRP	319	45.188	29.788	31.760	1.00	58.07	B2	ATOM	2300	CG	MET	322	42.527	34.865	30.658	1.00	51.76	B2
ATOM	2265	NE1	TRP	319	44.968	29.921	33.042	1.00	60.07	B2	ATOM	2301	SD	MET	322	40.861	34.428	31.189	1.00	54.19	B2
ATOM	2266	HE1	TRP	319	45.637	29.765	33.740	1.00	0.00	B2	ATOM	2302	CE	MET	322	40.293	33.192	30.069	1.00	52.53	B2

FIG. 56G

ATOM 2303	C MET 322	45.700	35.811	32.432	1.00	57.69	B2	ATOM 2339	O ALA 340	21.426	13.783	20.196	1.00	58.64	B3
ATOM 2304	O MET 322	45.781	36.739	33.248	1.00	57.85	B2	ATOM 2340	N PHE 341	23.516	13.734	19.514	1.00	53.34	B3
ATOM 2305	N GLU 323	46.652	34.900	32.319	1.00	60.28	B2	ATOM 2341	H PHE 341	24.472	13.607	19.685	1.00	0.00	B3
ATOM 2306	H GLU 323	46.637	34.296	31.544	1.00	0.00	B2	ATOM 2342	CA PHE 341	23.016	13.900	18.158	1.00	49.92	B3
ATOM 2307	CA GLU 323	47.741	34.875	33.273	1.00	62.99	B2	ATOM 2343	CB PHE 341	24.050	14.541	17.244	1.00	48.16	B3
ATOM 2308	CB GLU 323	48.558	33.635	32.957	1.00	65.81	B2	ATOM 2344	CG PHE 341	24.382	15.940	17.658	1.00	45.00	B3
ATOM 2309	CD GLU 323	47.640	32.423	32.918	1.00	68.36	B2	ATOM 2345	CD1 PHE 341	23.510	16.923	17.359	1.00	43.44	B3
ATOM 2310	CG GLU 323	48.303	31.125	33.310	1.00	71.21	B2	ATOM 2346	CD2 PHE 341	25.527	16.175	18.388	1.00	47.03	B3
ATOM 2311	OE1 GLU 323	47.651	30.364	34.044	1.00	71.19	B2	ATOM 2347	CE1 PHE 341	23.812	18.172	17.831	1.00	49.15	B3
ATOM 2312	OE2 GLU 323	49.451	30.900	32.884	1.00	72.43	B2	ATOM 2348	CE2 PHE 341	25.827	17.426	18.862	1.00	47.86	B3
ATOM 2313	C GLU 323	48.648	36.124	33.418	1.00	63.96	B2	ATOM 2349	CZ PHE 341	24.952	18.437	18.580	1.00	48.36	B3
ATOM 2314	OT1 GLU 323	48.782	36.492	34.584	1.00	64.11	B2	ATOM 2350	C PHE 341	22.684	12.510	17.672	1.00	49.56	B3
ATOM 2315	OT2 GLU 323	49.169	36.725	32.449	1.00	62.96	B2	ATOM 2351	O PHE 341	23.309	11.938	16.781	1.00	51.46	B3
ATOM 2316	CB MET 338	27.559	17.690	25.056	1.00	62.56	B3	ATOM 2352	N ALA 342	21.625	11.985	18.245	1.00	47.40	B3
ATOM 2317	CG MET 338	28.087	18.862	24.222	1.00	63.85	B3	ATOM 2353	H ALA 342	21.026	12.585	18.741	1.00	0.00	B3
ATOM 2318	SD MET 338	28.738	20.224	25.219	1.00	66.95	B3	ATOM 2354	CA ALA 342	21.167	10.650	17.997	1.00	46.11	B3
ATOM 2319	CE MET 338	27.328	21.252	25.515	1.00	65.50	B3	ATOM 2355	CB ALA 342	19.874	10.531	18.804	1.00	47.10	B3
ATOM 2320	C MET 338	24.988	17.301	25.122	1.00	57.55	B3	ATOM 2356	C ALA 342	20.962	10.149	16.556	1.00	44.37	B3
ATOM 2321	O MET 338	24.417	16.347	25.667	1.00	56.47	B3	ATOM 2357	O ALA 342	20.138	9.247	16.418	1.00	45.65	B3
ATOM 2322	HT1 MET 338	26.255	16.010	26.594	1.00	0.00	B3	ATOM 2358	N SER 343	21.537	10.573	15.423	1.00	41.37	B3
ATOM 2323	HT2 MET 338	25.375	17.061	27.500	1.00	0.00	B3	ATOM 2359	H SER 343	22.191	11.301	15.428	1.00	0.00	B3
ATOM 2324	N MET 338	26.286	16.971	27.009	1.00	61.55	B3	ATOM 2360	CA SER 343	21.274	9.923	14.145	1.00	38.80	B3
ATOM 2325	HT3 MET 338	27.108	17.107	27.620	1.00	0.00	B3	ATOM 2361	CB SER 343	19.842	10.138	13.656	1.00	38.79	B3
ATOM 2326	CA MET 338	26.226	17.853	25.851	1.00	60.35	B3	ATOM 2362	OG SER 343	19.205	11.300	14.182	1.00	37.75	B3
ATOM 2327	N PRO 339	24.493	17.830	23.998	1.00	55.58	B3	ATOM 2363	HG SER 343	18.963	11.059	15.092	1.00	0.00	B3
ATOM 2328	CD PRO 339	24.914	19.075	23.375	1.00	54.39	B3	ATOM 2364	C SER 343	22.172	10.467	13.088	1.00	38.22	B3
ATOM 2329	CA PRO 339	23.453	17.226	23.164	1.00	54.62	B3	ATOM 2365	O SER 343	22.810	11.471	13.382	1.00	38.30	B3
ATOM 2330	CB PRO 339	23.463	18.098	21.903	1.00	53.52	B3	ATOM 2366	N ALA 344	22.206	9.845	11.888	1.00	36.73	B3
ATOM 2331	CG PRO 339	24.845	18.711	21.909	1.00	53.04	B3	ATOM 2367	H ALA 344	21.762	8.978	11.805	1.00	0.00	B3
ATOM 2332	C PRO 339	23.666	15.748	22.881	1.00	53.61	B3	ATOM 2368	CA ALA 344	22.914	10.384	10.715	1.00	38.09	B3
ATOM 2333	O PRO 339	24.730	15.222	23.169	1.00	53.35	B3	ATOM 2369	CB ALA 344	22.583	9.640	9.422	1.00	36.78	B3
ATOM 2334	N ALA 340	22.704	15.045	22.333	1.00	54.32	B3	ATOM 2370	C ALA 344	22.472	11.842	10.496	1.00	37.72	B3
ATOM 2335	H ALA 340	21.844	15.460	22.111	1.00	0.00	B3	ATOM 2371	O ALA 344	23.271	12.765	10.676	1.00	38.42	B3
ATOM 2336	CA ALA 340	22.909	13.651	21.968	1.00	56.04	B3	ATOM 2372	N PHE 345	21.194	12.042	10.163	1.00	36.10	B3
ATOM 2337	CB ALA 340	21.867	12.713	22.625	1.00	57.60	B3	ATOM 2373	H PHE 345	20.668	11.298	9.811	1.00	0.00	B3
ATOM 2338	C ALA 340	22.617	13.713	20.495	1.00	55.61	B3	ATOM 2374	CA PHE 345	20.564	13.338	10.195	1.00	34.69	B3

FIG. 5HH

ATOM 2375	CB	PHE	345	19.040	13.254	10.128	1.00	33.24	ATOM 2411	C	ARG	347	25.183	15.544	12.267	1.00	35.54	B3
ATOM 2376	CG	PHE	345	18.462	14.656	9.918	1.00	31.72	ATOM 2412	O	ARG	347	25.877	16.549	12.445	1.00	36.73	B3
ATOM 2377	CD1	PHE	345	17.715	15.223	10.905	1.00	26.64	ATOM 2413	N	ARG	348	24.611	15.353	11.096	1.00	34.74	B3
ATOM 2378	CD2	PHE	345	18.767	15.343	8.745	1.00	29.99	ATOM 2414	H	ARG	348	24.043	14.559	11.005	1.00	0.00	B3
ATOM 2379	CE1	PHE	345	17.284	16.503	10.682	1.00	33.56	ATOM 2415	CA	ARG	348	24.802	16.225	9.954	1.00	35.24	B3
ATOM 2380	CE2	PHE	345	18.333	16.619	8.537	1.00	30.81	ATOM 2416	CB	ARG	348	24.091	15.623	8.751	1.00	36.76	B3
ATOM 2381	CZ	PHE	345	17.581	17.201	9.520	1.00	31.44	ATOM 2417	CG	ARG	348	24.778	14.303	8.450	1.00	44.22	B3
ATOM 2382	C	PHE	345	20.888	14.145	11.458	1.00	35.02	ATOM 2418	CD	ARG	348	24.014	13.379	7.529	1.00	49.23	B3
ATOM 2383	O	PHE	345	21.246	15.319	11.292	1.00	37.81	ATOM 2419	NE	ARG	348	24.705	12.090	7.457	1.00	54.27	B3
ATOM 2384	N	GLN	346	20.814	13.688	12.691	1.00	32.53	ATOM 2420	HE	ARG	348	25.300	11.836	8.193	1.00	0.00	B3
ATOM 2385	H	GLN	346	20.516	12.778	12.894	1.00	0.00	ATOM 2421	CZ	ARG	348	24.557	11.226	6.430	1.00	53.75	B3
ATOM 2386	CA	GLN	346	21.156	14.586	13.758	1.00	33.46	ATOM 2422	NH1	ARG	348	23.758	11.479	5.381	1.00	51.85	B3
ATOM 2387	CB	GLN	346	20.899	13.985	15.061	1.00	33.80	ATOM 2423	HH11	ARG	348	23.234	12.329	5.339	1.00	0.00	B3
ATOM 2388	CG	GLN	346	19.459	14.284	15.174	1.00	35.68	ATOM 2424	HH12	ARG	348	23.680	10.807	4.645	1.00	0.00	B3
ATOM 2389	CD	GLN	346	18.788	13.658	16.344	1.00	38.48	ATOM 2425	NH2	ARG	348	25.252	10.083	6.462	1.00	54.51	B3
ATOM 2390	OE1	GLN	346	19.358	13.328	17.374	1.00	41.78	ATOM 2426	HH21	ARG	348	25.169	9.424	5.714	1.00	0.00	B3
ATOM 2391	NE2	GLN	346	17.508	13.463	16.167	1.00	41.08	ATOM 2427	HH22	ARG	348	25.860	9.894	7.232	1.00	0.00	B3
ATOM 2392	HE21	GLN	346	17.088	13.724	15.323	1.00	0.00	ATOM 2428	C	ARG	348	24.283	17.629	10.237	1.00	34.80	B3
ATOM 2393	HE22	GLN	346	17.026	13.063	16.919	1.00	0.00	ATOM 2429	O	ARG	348	25.078	18.564	10.219	1.00	35.16	B3
ATOM 2394	C	GLN	346	22.564	15.051	13.773	1.00	35.73	ATOM 2430	N	ALA	349	23.008	17.795	10.607	1.00	33.85	B3
ATOM 2395	O	GLN	346	22.766	16.231	14.051	1.00	38.18	ATOM 2431	H	ALA	349	22.470	16.984	10.755	1.00	0.00	B3
ATOM 2396	N	ARG	347	23.507	14.190	13.431	1.00	35.57	ATOM 2432	CA	ALA	349	22.352	19.083	10.853	1.00	32.96	B3
ATOM 2397	H	ARG	347	23.248	13.289	13.157	1.00	0.00	ATOM 2433	CB	ALA	349	20.809	18.894	11.070	1.00	33.36	B3
ATOM 2398	CA	ARG	347	24.907	14.538	13.396	1.00	35.95	ATOM 2434	C	ALA	349	22.945	19.746	12.083	1.00	31.84	B3
ATOM 2399	CB	ARG	347	25.760	13.236	13.222	1.00	36.20	ATOM 2435	O	ALA	349	22.981	20.969	12.210	1.00	30.69	B3
ATOM 2400	CG	ARG	347	26.198	12.549	14.540	1.00	37.41	ATOM 2436	N	GLY	350	23.444	18.954	13.018	1.00	31.30	B3
ATOM 2401	CD	ARG	347	26.986	11.246	14.373	1.00	39.70	ATOM 2437	H	GLY	350	23.308	17.984	12.976	1.00	0.00	B3
ATOM 2402	NE	ARG	347	26.072	10.167	14.028	1.00	47.18	ATOM 2438	CA	GLY	350	24.117	19.505	14.181	1.00	31.08	B3
ATOM 2403	HE	ARG	347	25.416	9.893	14.701	1.00	0.00	ATOM 2439	C	GLY	350	25.462	20.025	13.753	1.00	30.79	B3
ATOM 2404	CZ	ARG	347	26.071	9.516	12.846	1.00	48.49	ATOM 2440	O	GLY	350	25.974	21.010	14.280	1.00	31.38	B3
ATOM 2405	NH1	ARG	347	26.938	9.802	11.882	1.00	50.22	ATOM 2441	N	GLY	351	25.991	19.374	12.731	1.00	30.03	B3
ATOM 2406	HH11	ARG	347	27.602	10.528	12.031	1.00	0.00	ATOM 2442	H	GLY	351	25.546	18.582	12.367	1.00	0.00	B3
ATOM 2407	HH12	ARG	347	26.905	9.313	11.011	1.00	0.00	ATOM 2443	CA	GLY	351	27.263	19.735	12.184	1.00	29.95	B3
ATOM 2408	NH2	ARG	347	25.130	8.608	12.574	1.00	48.46	ATOM 2444	C	GLY	351	27.182	21.097	11.534	1.00	29.25	B3
ATOM 2409	HH21	ARG	347	24.423	8.408	13.252	1.00	0.00	ATOM 2445	O	GLY	351	27.937	21.974	11.919	1.00	28.73	B3
ATOM 2410	HH22	ARG	347	25.126	8.131	11.697	1.00	0.00	ATOM 2446	N	VAL	352	26.336	21.285	10.522	1.00	28.92	B3

FIG. 51I

ATOM 2447	H VAL 352	25.859	20.484	10.214	1.00	0.00	B3	ATOM 2483	C SER 356	27.763	29.095	12.901	1.00	29.75	B3
ATOM 2448	CA VAL 352	26.079	22.567	9.881	1.00	28.59	B3	ATOM 2484	O SER 356	28.115	30.289	12.898	1.00	28.35	B3
ATOM 2449	CB VAL 352	24.845	22.452	9.004	1.00	28.96	B3	ATOM 2485	N HIS 357	27.465	28.464	14.025	1.00	27.82	B3
ATOM 2450	CG1 VAL 352	24.627	23.785	8.346	1.00	30.86	B3	ATOM 2486	H HIS 357	27.301	27.498	14.019	1.00	0.00	B3
ATOM 2451	CG2 VAL 352	25.021	21.475	7.875	1.00	26.94	B3	ATOM 2487	CA HIS 357	27.434	29.194	15.259	1.00	26.58	B3
ATOM 2452	C VAL 352	25.849	23.709	10.890	1.00	29.29	B3	ATOM 2488	CB HIS 357	26.735	28.365	16.305	1.00	25.77	B3
ATOM 2453	O VAL 352	26.520	24.747	10.853	1.00	31.02	B3	ATOM 2489	CG HIS 357	25.219	28.360	16.063	1.00	27.67	B3
ATOM 2454	N LEU 353	24.923	23.543	11.819	1.00	27.52	B3	ATOM 2490	CD2 HIS 357	24.563	28.767	14.915	1.00	28.94	B3
ATOM 2455	H LEU 353	24.404	22.709	11.838	1.00	0.00	B3	ATOM 2491	ND1 HIS 357	24.277	27.963	16.915	1.00	28.43	B3
ATOM 2456	CA LEU 353	24.635	24.548	12.817	1.00	26.18	B3	ATOM 2492	HD1 HIS 357	24.456	27.622	17.828	1.00	0.00	B3
ATOM 2457	CB LEU 353	23.434	24.113	13.636	1.00	27.87	B3	ATOM 2493	CE1 HIS 357	23.112	28.103	16.337	1.00	28.64	B3
ATOM 2458	CG LEU 353	22.098	24.034	12.931	1.00	26.54	B3	ATOM 2494	NE2 HIS 357	23.298	28.589	15.130	1.00	29.48	B3
ATOM 2459	CD1 LEU 353	21.064	23.617	13.924	1.00	25.49	B3	ATOM 2495	HE2 HIS 357	22.576	28.801	14.495	1.00	0.00	B3
ATOM 2460	CD2 LEU 353	21.750	25.372	12.320	1.00	28.23	B3	ATOM 2496	C HIS 357	28.852	29.506	15.645	1.00	27.93	B3
ATOM 2461	C LEU 353	25.742	24.905	13.772	1.00	27.17	B3	ATOM 2497	O HIS 357	29.119	30.606	16.115	1.00	29.15	B3
ATOM 2462	O LEU 353	25.838	26.093	14.088	1.00	28.00	B3	ATOM 2498	N LEU 358	29.830	28.637	15.383	1.00	28.33	B3
ATOM 2463	N VAL 354	26.539	23.949	14.318	1.00	27.20	B3	ATOM 2499	H LEU 358	29.624	27.761	14.997	1.00	0.00	B3
ATOM 2464	H VAL 354	26.321	23.006	14.139	1.00	0.00	B3	ATOM 2500	CA LEU 358	31.211	28.940	15.721	1.00	26.39	B3
ATOM 2465	CA VAL 354	27.712	24.212	15.157	1.00	24.62	B3	ATOM 2501	CB LEU 358	32.030	27.702	15.547	1.00	21.42	B3
ATOM 2466	CB VAL 354	28.236	22.910	15.745	1.00	22.01	B3	ATOM 2502	CG LEU 358	33.457	27.878	15.734	1.00	20.42	B3
ATOM 2467	CG1 VAL 354	29.568	23.089	16.406	1.00	19.82	B3	ATOM 2503	CD1 LEU 358	33.805	28.078	17.165	1.00	16.79	B3
ATOM 2468	CG2 VAL 354	27.276	22.467	16.802	1.00	23.96	B3	ATOM 2504	CD2 LEU 358	34.075	26.714	15.072	1.00	22.89	B3
ATOM 2469	C VAL 354	28.812	24.893	14.332	1.00	25.46	B3	ATOM 2505	C LEU 358	31.721	30.067	14.822	1.00	26.45	B3
ATOM 2470	O VAL 354	29.439	25.832	14.798	1.00	26.23	B3	ATOM 2506	O LEU 358	32.372	30.939	15.378	1.00	27.12	B3
ATOM 2471	N ALA 355	29.059	24.530	13.089	1.00	26.12	B3	ATOM 2507	N GLN 359	31.460	30.130	13.518	1.00	26.41	B3
ATOM 2472	H ALA 355	28.579	23.745	12.744	1.00	0.00	B3	ATOM 2508	H GLN 359	31.048	29.337	13.114	1.00	0.00	B3
ATOM 2473	CA ALA 355	30.025	25.180	12.235	1.00	26.54	B3	ATOM 2509	CA GLN 359	31.863	31.254	12.671	1.00	29.10	B3
ATOM 2474	CB ALA 355	30.034	24.591	10.869	1.00	22.08	B3	ATOM 2510	CB GLN 359	31.204	31.209	11.292	1.00	30.49	B3
ATOM 2475	C ALA 355	29.533	26.601	12.096	1.00	28.51	B3	ATOM 2511	CG GLN 359	31.395	29.952	10.455	1.00	38.94	B3
ATOM 2476	O ALA 355	30.315	27.498	12.344	1.00	31.93	B3	ATOM 2512	CD GLN 359	32.842	29.636	10.091	1.00	42.09	B3
ATOM 2477	N SER 356	28.271	26.884	11.802	1.00	30.30	B3	ATOM 2513	OE1 GLN 359	33.774	29.979	10.821	1.00	46.15	B3
ATOM 2478	H SER 356	27.654	26.134	11.665	1.00	0.00	B3	ATOM 2514	NE2 GLN 359	33.103	28.987	8.967	1.00	41.34	B3
ATOM 2479	CA SER 356	27.778	28.249	11.625	1.00	31.10	B3	ATOM 2515	HE21 GLN 359	32.341	28.706	8.412	1.00	0.00	B3
ATOM 2480	CB SER 356	26.401	28.147	11.016	1.00	35.23	B3	ATOM 2516	HE22 GLN 359	34.039	28.838	8.740	1.00	0.00	B3
ATOM 2481	OG SER 356	25.679	29.380	10.905	1.00	43.82	B3	ATOM 2517	C GLN 359	31.512	32.621	13.254	1.00	29.39	B3
ATOM 2482	HG SER 356	26.250	30.004	10.429	1.00	0.00	B3	ATOM 2518	O GLN 359	32.427	33.427	13.484	1.00	30.06	B3

FIG. 5JJ

ATOM 2519	N SER 360	30.201	32.810	13.528	1.00	28.66	ATOM 2555	OE2 GLU 363	34.051	38.734	11.488	1.00	46.47	B3
ATOM 2520	H SER 360	29.595	32.061	13.343	1.00	0.00	ATOM 2556	C GLU 363	33.229	38.098	15.244	1.00	30.19	B3
ATOM 2521	CA SER 360	29.570	34.003	14.071	1.00	27.31	ATOM 2557	O GLU 363	33.837	39.167	15.239	1.00	30.26	B3
ATOM 2522	CB SER 360	28.121	33.761	14.336	1.00	26.70	ATOM 2558	N VAL 364	32.397	37.726	16.217	1.00	30.04	B3
ATOM 2523	OG SER 360	27.493	33.539	13.078	1.00	29.72	ATOM 2559	H VAL 364	31.888	36.898	16.100	1.00	0.00	B3
ATOM 2524	HG SER 360	26.637	33.112	13.288	1.00	0.00	ATOM 2560	CA VAL 364	32.178	38.522	17.400	1.00	31.90	B3
ATOM 2525	C SER 360	30.202	34.387	15.353	1.00	27.15	ATOM 2561	CB VAL 364	31.014	38.021	18.269	1.00	31.41	B3
ATOM 2526	O SER 360	30.575	35.550	15.498	1.00	26.93	ATOM 2562	CG1 VAL 364	30.860	38.811	19.562	1.00	30.73	B3
ATOM 2527	N PHE 361	30.383	33.403	16.246	1.00	25.38	ATOM 2563	CG2 VAL 364	29.750	38.200	17.497	1.00	29.96	B3
ATOM 2528	H PHE 361	30.055	32.499	16.040	1.00	0.00	ATOM 2564	C VAL 364	33.402	38.493	18.275	1.00	35.89	B3
ATOM 2529	CA PHE 361	31.066	33.626	17.517	1.00	25.20	ATOM 2565	O VAL 364	33.683	39.535	18.855	1.00	37.54	B3
ATOM 2530	CB PHE 361	31.092	32.335	18.302	1.00	23.30	ATOM 2566	N SER 365	34.173	37.421	18.477	1.00	38.25	B3
ATOM 2531	CG PHE 361	31.796	32.394	19.655	1.00	23.63	ATOM 2567	H SER 365	33.971	36.577	18.030	1.00	0.00	B3
ATOM 2532	CD1 PHE 361	31.127	32.854	20.777	1.00	22.44	ATOM 2568	CA SER 365	35.337	37.478	19.375	1.00	39.61	B3
ATOM 2533	CD2 PHE 361	33.098	31.931	19.770	1.00	23.35	ATOM 2569	CB SER 365	36.041	36.113	19.555	1.00	43.00	B3
ATOM 2534	CE1 PHE 361	31.772	32.834	22.000	1.00	22.78	ATOM 2570	OG SER 365	35.201	34.953	19.575	1.00	46.29	B3
ATOM 2535	CE2 PHE 361	33.719	31.921	21.002	1.00	21.26	ATOM 2571	HG SER 365	34.270	35.189	19.644	1.00	0.00	B3
ATOM 2536	CZ PHE 361	33.058	32.368	22.114	1.00	19.54	ATOM 2572	C SER 365	36.398	38.418	18.840	1.00	38.21	B3
ATOM 2537	C PHE 361	32.505	34.143	17.385	1.00	26.56	ATOM 2573	O SER 365	37.103	38.989	19.662	1.00	36.91	B3
ATOM 2538	O PHE 361	32.914	34.979	18.183	1.00	26.76	ATOM 2574	N TYR 366	36.575	38.540	17.514	1.00	38.00	B3
ATOM 2539	N LEU 362	33.309	33.645	16.441	1.00	28.17	ATOM 2575	H TYR 366	36.079	37.945	16.910	1.00	0.00	B3
ATOM 2540	H LEU 362	32.962	32.921	15.874	1.00	0.00	ATOM 2576	CA TYR 366	37.568	39.463	16.969	1.00	39.85	B3
ATOM 2541	CA LEU 362	34.679	34.089	16.222	1.00	28.89	ATOM 2577	CB TYR 366	37.776	39.330	15.436	1.00	38.53	B3
ATOM 2542	CB LEU 362	35.452	33.125	15.338	1.00	28.18	ATOM 2578	CG TYR 366	38.662	40.447	14.879	1.00	38.21	B3
ATOM 2543	CG LEU 362	35.603	31.656	15.781	1.00	29.61	ATOM 2579	CD1 TYR 366	38.104	41.464	14.129	1.00	37.18	B3
ATOM 2544	CD1 LEU 362	36.306	30.996	14.633	1.00	31.63	ATOM 2580	CE1 TYR 366	38.918	42.495	13.678	1.00	41.77	B3
ATOM 2545	CD2 LEU 362	36.374	31.433	17.055	1.00	26.38	ATOM 2581	CD2 TYR 366	40.021	40.443	15.182	1.00	40.21	B3
ATOM 2546	C LEU 362	34.692	35.449	15.536	1.00	29.18	ATOM 2582	CE2 TYR 366	40.849	41.466	14.739	1.00	40.76	B3
ATOM 2547	O LEU 362	35.649	36.202	15.748	1.00	27.43	ATOM 2583	CZ TYR 366	40.297	42.504	13.976	1.00	42.82	B3
ATOM 2548	N GLU 363	33.664	35.763	14.710	1.00	29.54	ATOM 2584	OH TYR 366	41.151	43.522	13.493	1.00	41.30	B3
ATOM 2549	H GLU 363	33.009	35.066	14.495	1.00	0.00	ATOM 2585	HH TYR 366	40.743	43.977	12.755	1.00	0.00	B3
ATOM 2550	CA GLU 363	33.496	37.090	14.145	1.00	30.30	ATOM 2586	C TYR 366	37.133	40.893	17.241	1.00	40.55	B3
ATOM 2551	CB GLU 363	32.357	37.147	13.228	1.00	30.90	ATOM 2587	O TYR 366	37.917	41.647	17.798	1.00	40.92	B3
ATOM 2552	CG GLU 363	32.763	36.735	11.849	1.00	38.69	ATOM 2588	N ARG 367	35.933	41.309	16.853	1.00	41.88	B3
ATOM 2553	CD GLU 363	33.642	37.662	11.013	1.00	42.62	ATOM 2589	H ARG 367	35.360	40.682	16.360	1.00	0.00	B3
ATOM 2554	OE1 GLU 363	33.896	37.282	9.860	1.00	46.58	ATOM 2590	CA ARG 367	35.442	42.653	17.139	1.00	43.32	B3

FIG. 5KK

ATOM 2591	CB ARG 367	34.013	42.709	16.650	1.00	46.82	ATOM 2627	CD ARG 370	40.894	45.910	16.169	1.00	45.37	B3
ATOM 2592	CG ARG 367	33.528	44.130	16.650	1.00	56.74	ATOM 2628	NE ARG 370	41.219	46.681	14.976	1.00	48.00	B3
ATOM 2593	CD ARG 367	32.069	44.267	16.248	1.00	61.81	ATOM 2629	HE ARG 370	40.524	46.867	14.312	1.00	0.00	B3
ATOM 2594	NE ARG 367	31.723	45.687	16.229	1.00	66.59	ATOM 2630	CZ ARG 370	42.469	47.153	14.791	1.00	48.45	B3
ATOM 2595	HE ARG 367	32.438	46.356	16.172	1.00	0.00	ATOM 2631	NH1 ARG 370	43.443	46.961	15.691	1.00	49.13	B3
ATOM 2596	CZ ARG 367	30.458	46.091	16.308	1.00	69.75	ATOM 2632	HH11 ARG 370	43.262	46.456	16.534	1.00	0.00	B3
ATOM 2597	NH1 ARG 367	29.448	45.220	16.413	1.00	72.65	ATOM 2633	HH12 ARG 370	44.357	47.326	15.520	1.00	0.00	B3
ATOM 2598	HH11 ARG 367	29.631	44.236	16.410	1.00	0.00	ATOM 2634	NH2 ARG 370	42.821	47.710	13.635	1.00	47.59	B3
ATOM 2599	HH12 ARG 367	28.503	45.548	16.445	1.00	0.00	ATOM 2635	HH21 ARG 370	42.163	47.785	12.889	1.00	0.00	B3
ATOM 2600	NH2 ARG 367	30.160	47.375	16.162	1.00	71.64	ATOM 2636	HH22 ARG 370	43.751	48.057	13.516	1.00	0.00	B3
ATOM 2601	HH21 ARG 367	29.204	47.665	16.222	1.00	0.00	ATOM 2637	C ARG 370	39.386	45.740	19.558	1.00	49.12	B3
ATOM 2602	HH22 ARG 367	30.888	48.043	16.013	1.00	0.00	ATOM 2638	O ARG 370	40.216	46.615	19.826	1.00	49.67	B3
ATOM 2603	C ARG 367	35.551	43.011	18.635	1.00	40.96	ATOM 2639	N HIS 371	38.162	45.728	20.123	1.00	52.30	B3
ATOM 2604	O ARG 367	35.994	44.090	19.012	1.00	41.10	ATOM 2640	H HIS 371	37.581	44.955	19.949	1.00	0.00	B3
ATOM 2605	N VAL 368	35.160	42.135	19.542	1.00	39.83	ATOM 2641	CA HIS 371	37.745	46.738	21.080	1.00	56.65	B3
ATOM 2606	H VAL 368	34.726	41.316	19.217	1.00	0.00	ATOM 2642	CB HIS 371	36.284	46.604	21.459	1.00	62.15	B3
ATOM 2607	CA VAL 368	35.331	42.292	20.968	1.00	37.33	ATOM 2643	CG HIS 371	35.320	46.991	20.346	1.00	71.70	B3
ATOM 2608	CB VAL 368	34.748	41.043	21.664	1.00	35.75	ATOM 2644	CD2 HIS 371	35.596	47.877	19.313	1.00	75.03	B3
ATOM 2609	CG1 VAL 368	35.087	40.867	23.140	1.00	35.10	ATOM 2645	ND1 HIS 371	34.067	46.546	20.166	1.00	75.91	B3
ATOM 2610	CG2 VAL 368	33.259	41.230	21.586	1.00	33.28	ATOM 2646	HDI HIS 371	33.594	45.897	20.732	1.00	0.00	B3
ATOM 2611	C VAL 368	36.813	42.459	21.223	1.00	38.75	ATOM 2647	CE1 HIS 371	33.580	47.116	19.077	1.00	77.30	B3
ATOM 2612	O VAL 368	37.144	43.498	21.772	1.00	40.11	ATOM 2648	NE2 HIS 371	34.507	47.914	18.573	1.00	77.52	B3
ATOM 2613	N LEU 369	37.759	41.600	20.835	1.00	39.59	ATOM 2649	HE2 HIS 371	34.401	48.460	17.764	1.00	0.00	B3
ATOM 2614	H LEU 369	37.492	40.818	20.308	1.00	0.00	ATOM 2650	C HIS 371	38.533	46.669	22.382	1.00	56.97	B3
ATOM 2615	CA LEU 369	39.180	41.780	21.148	1.00	40.05	ATOM 2651	O HIS 371	38.458	47.592	23.176	1.00	58.12	B3
ATOM 2616	CB LEU 369	39.984	40.601	20.679	1.00	37.15	ATOM 2652	N LEU 372	39.271	45.632	22.715	1.00	56.98	B3
ATOM 2617	CG LEU 369	39.831	39.335	21.426	1.00	37.54	ATOM 2653	H LEU 372	39.302	44.855	22.122	1.00	0.00	B3
ATOM 2618	CD1 LEU 369	40.349	38.238	20.528	1.00	39.70	ATOM 2654	CA LEU 372	40.048	45.597	23.939	1.00	57.77	B3
ATOM 2619	CD2 LEU 369	40.563	39.394	22.747	1.00	36.86	ATOM 2655	CB LEU 372	39.725	44.272	24.633	1.00	57.29	B3
ATOM 2620	C LEU 369	39.817	43.031	20.542	1.00	41.88	ATOM 2656	CG LEU 372	38.566	44.144	25.611	1.00	55.87	B3
ATOM 2621	O LEU 369	40.711	43.654	21.144	1.00	41.30	ATOM 2657	CD1 LEU 372	37.358	44.892	25.123	1.00	55.77	B3
ATOM 2622	N ARG 370	39.333	43.413	19.354	1.00	42.80	ATOM 2658	CD2 LEU 372	38.211	42.675	25.749	1.00	55.33	B3
ATOM 2623	H ARG 370	38.619	42.884	18.957	1.00	0.00	ATOM 2659	C LEU 372	41.554	45.755	23.647	1.00	58.81	B3
ATOM 2624	CA ARG 370	39.819	44.577	18.663	1.00	44.96	ATOM 2660	O LEU 372	42.447	45.475	24.476	1.00	59.12	B3
ATOM 2625	CB ARG 370	39.184	44.569	17.316	1.00	42.06	ATOM 2661	N ALA 373	41.942	46.168	22.447	1.00	59.27	B3
ATOM 2626	CG ARG 370	39.424	45.719	16.371	1.00	43.93	ATOM 2662	H ALA 373	41.271	46.255	21.731	1.00	0.00	B3

FIG. 5LL

ATOM 2663	CA	ALA	373	43.336	46.425	22.147	1.00	60.03	ATOM 2699	H	SER	413	24.693	55.976	4.492	1.00	0.00	C1
ATOM 2664	CB	ALA	373	43.755	45.485	21.021	1.00	59.87	ATOM 2700	CA	SER	413	26.696	55.984	5.144	1.00	48.75	C1
ATOM 2665	C	ALA	373	43.616	47.895	21.762	1.00	61.22	ATOM 2701	CB	SER	413	26.261	56.344	6.548	1.00	50.61	C1
ATOM 2666	OT1	ALA	373	44.798	48.243	21.697	1.00	62.45	ATOM 2702	OG	SER	413	27.378	56.872	7.301	1.00	53.05	C1
ATOM 2667	OT2	ALA	373	42.682	48.700	21.583	1.00	61.55	ATOM 2703	HG	SER	413	28.178	56.355	7.145	1.00	0.00	C1
ATOM 2668	CB	LEU	410	23.866	49.243	1.118	1.00	53.10	ATOM 2704	C	SER	413	27.480	54.684	5.267	1.00	48.71	C1
ATOM 2669	CG	LEU	410	23.982	47.812	0.738	1.00	51.85	ATOM 2705	O	SER	413	28.698	54.839	5.392	1.00	50.77	C1
ATOM 2670	CD1	LEU	410	25.074	47.596	-0.330	1.00	52.64	ATOM 2706	N	PHE	414	26.947	53.440	5.208	1.00	46.01	C1
ATOM 2671	CD2	LEU	410	24.125	47.081	2.058	1.00	49.28	ATOM 2707	H	PHE	414	25.996	53.323	5.015	1.00	0.00	C1
ATOM 2672	C	LEU	410	22.381	51.214	1.635	1.00	52.99	ATOM 2708	CA	PHE	414	27.787	52.233	5.274	1.00	42.92	C1
ATOM 2673	O	LEU	410	22.242	52.166	0.845	1.00	53.00	ATOM 2709	CB	PHE	414	26.959	50.915	5.232	1.00	40.76	C1
ATOM 2674	HT1	LEU	410	22.721	50.836	-0.665	1.00	0.00	ATOM 2710	CG	PHE	414	27.633	49.627	4.757	1.00	35.06	C1
ATOM 2675	HT2	LEU	410	21.194	50.178	-0.557	1.00	0.00	ATOM 2711	CD1	PHE	414	27.583	49.256	3.425	1.00	34.71	C1
ATOM 2676	N	LEU	410	22.198	49.968	-0.415	1.00	54.31	ATOM 2712	CD2	PHE	414	28.262	48.800	5.663	1.00	34.81	C1
ATOM 2677	HT3	LEU	410	22.529	49.174	-0.998	1.00	0.00	ATOM 2713	CE1	PHE	414	28.156	48.056	3.014	1.00	36.16	C1
ATOM 2678	CA	LEU	410	22.478	49.815	1.004	1.00	53.64	ATOM 2714	CE2	PHE	414	28.832	47.602	5.247	1.00	33.40	C1
ATOM 2679	N	PRO	411	22.450	51.433	2.965	1.00	52.95	ATOM 2715	CZ	PHE	414	28.781	47.223	3.923	1.00	34.22	C1
ATOM 2680	CD	PRO	411	22.466	50.407	4.022	1.00	52.54	ATOM 2716	C	PHE	414	28.667	52.271	4.044	1.00	41.25	C1
ATOM 2681	CA	PRO	411	22.666	52.766	3.548	1.00	53.25	ATOM 2717	O	PHE	414	29.831	51.902	4.110	1.00	41.47	C1
ATOM 2682	CB	PRO	411	22.688	52.541	5.068	1.00	52.85	ATOM 2718	N	LEU	415	28.122	52.748	2.942	1.00	39.50	C1
ATOM 2683	CG	PRO	411	23.163	51.108	5.203	1.00	52.83	ATOM 2719	H	LEU	415	27.188	53.044	2.946	1.00	0.00	C1
ATOM 2684	C	PRO	411	23.958	53.413	3.023	1.00	53.47	ATOM 2720	CA	LEU	415	28.865	52.769	1.721	1.00	39.91	C1
ATOM 2685	O	PRO	411	25.073	52.878	3.167	1.00	54.02	ATOM 2721	CB	LEU	415	27.946	53.205	0.641	1.00	41.98	C1
ATOM 2686	N	GLN	412	23.787	54.599	2.411	1.00	52.79	ATOM 2722	CG	LEU	415	27.903	52.274	-0.526	1.00	44.75	C1
ATOM 2687	H	GLN	412	22.863	54.900	2.294	1.00	0.00	ATOM 2723	CD1	LEU	415	26.430	51.951	-0.780	1.00	42.93	C1
ATOM 2688	CA	GLN	412	24.873	55.413	1.871	1.00	50.44	ATOM 2724	CD2	LEU	415	28.793	52.853	-1.648	1.00	45.91	C1
ATOM 2689	CB	GLN	412	24.387	56.762	1.413	1.00	52.47	ATOM 2725	C	LEU	415	30.081	53.669	1.755	1.00	40.03	C1
ATOM 2690	CG	GLN	412	25.364	57.408	0.437	1.00	56.51	ATOM 2726	O	LEU	415	31.142	53.348	1.183	1.00	40.28	C1
ATOM 2691	CD	GLN	412	25.228	56.954	-1.017	1.00	59.40	ATOM 2727	N	LEU	416	29.901	54.779	2.487	1.00	37.46	C1
ATOM 2692	OE1	GLN	412	25.869	57.506	-1.913	1.00	59.67	ATOM 2728	H	LEU	416	29.028	54.948	2.899	1.00	0.00	C1
ATOM 2693	NE2	GLN	412	24.336	56.022	-1.389	1.00	60.12	ATOM 2729	CA	LEU	416	30.942	55.756	2.602	1.00	34.05	C1
ATOM 2694	HE21	GLN	412	23.734	55.616	-0.737	1.00	0.00	ATOM 2730	CB	LEU	416	30.294	57.089	2.998	1.00	34.67	C1
ATOM 2695	HE22	GLN	412	24.396	55.748	-2.328	1.00	0.00	ATOM 2731	CG	LEU	416	29.438	57.704	1.851	1.00	35.24	C1
ATOM 2696	C	GLN	412	25.930	55.646	2.916	1.00	48.22	ATOM 2732	CD1	LEU	416	28.770	58.948	2.358	1.00	31.87	C1
ATOM 2697	O	GLN	412	27.089	55.591	2.545	1.00	46.78	ATOM 2733	CD2	LEU	416	30.310	57.948	0.593	1.00	35.50	C1
ATOM 2698	N	SER	413	25.614	55.842	4.201	1.00	47.90	ATOM 2734	C	LEU	416	31.952	55.258	3.586	1.00	31.97	C1

FIG. 5MM

ATOM 2735	O	LEU	416	33.131	55.427	3.270	1.00	33.32	CI	ATOM 2771	CB	GLN	421	37.545	50.389	4.984	1.00	30.88	CI
ATOM 2736	N	ALA	417	31.573	54.619	4.695	1.00	29.05	CI	ATOM 2772	CG	GLN	421	37.308	50.634	6.463	1.00	33.58	CI
ATOM 2737	H	ALA	417	30.621	54.616	4.927	1.00	0.00	CI	ATOM 2773	CD	GLN	421	36.320	49.625	7.058	1.00	37.89	CI
ATOM 2738	CA	ALA	417	32.524	53.882	5.561	1.00	29.64	CI	ATOM 2774	OE1	GLN	421	35.357	49.236	6.398	1.00	43.18	CI
ATOM 2739	CB	ALA	417	31.853	53.087	6.680	1.00	25.16	CI	ATOM 2775	NE2	GLN	421	36.427	49.095	8.275	1.00	37.13	CI
ATOM 2740	C	ALA	417	33.319	52.827	4.777	1.00	30.68	CI	ATOM 2776	HE21	GLN	421	35.695	48.505	8.556	1.00	0.00	CI
ATOM 2741	O	ALA	417	34.536	52.721	4.877	1.00	31.52	CI	ATOM 2777	HE22	GLN	421	37.207	49.330	8.812	1.00	0.00	CI
ATOM 2742	N	CYS	418	32.726	52.041	3.905	1.00	32.19	CI	ATOM 2778	C	GLN	421	38.991	50.862	3.026	1.00	27.36	CI
ATOM 2743	H	CYS	418	31.748	52.017	3.860	1.00	0.00	CI	ATOM 2779	O	GLN	421	40.152	50.445	3.099	1.00	29.09	CI
ATOM 2744	CA	CYS	418	33.499	51.119	3.103	1.00	33.67	CI	ATOM 2780	N	VAL	422	38.379	50.845	1.847	1.00	23.57	CI
ATOM 2745	CB	CYS	418	32.657	50.250	2.226	1.00	33.85	CI	ATOM 2781	H	VAL	422	37.448	51.138	1.803	1.00	0.00	CI
ATOM 2746	SG	CYS	418	31.623	49.208	3.246	1.00	37.80	CI	ATOM 2782	CA	VAL	422	39.077	50.420	0.651	1.00	23.52	CI
ATOM 2747	C	CYS	418	34.446	51.818	2.170	1.00	34.80	CI	ATOM 2783	CB	VAL	422	38.163	50.636	-0.556	1.00	22.67	CI
ATOM 2748	O	CYS	418	35.626	51.441	2.173	1.00	36.47	CI	ATOM 2784	CG1	VAL	422	38.873	50.455	-1.868	1.00	21.56	CI
ATOM 2749	N	LEU	419	34.009	52.820	1.377	1.00	35.00	CI	ATOM 2785	CG2	VAL	422	37.057	49.610	-0.465	1.00	26.79	CI
ATOM 2750	H	LEU	419	33.082	53.131	1.460	1.00	0.00	CI	ATOM 2786	C	VAL	422	40.353	51.254	0.514	1.00	26.22	CI
ATOM 2751	CA	LEU	419	34.886	53.446	0.375	1.00	34.14	CI	ATOM 2787	O	VAL	422	41.458	50.708	0.508	1.00	28.77	CI
ATOM 2752	CB	LEU	419	34.062	54.484	-0.413	1.00	37.09	CI	ATOM 2788	N	ARG	423	40.275	52.599	0.575	1.00	27.49	CI
ATOM 2753	CG	LEU	419	32.866	53.853	-1.244	1.00	39.61	CI	ATOM 2789	H	ARG	423	39.402	53.016	0.735	1.00	0.00	CI
ATOM 2754	CD1	LEU	419	31.866	54.918	-1.609	1.00	39.24	CI	ATOM 2790	CA	ARG	423	41.436	53.456	0.346	1.00	25.91	CI
ATOM 2755	CD2	LEU	419	33.349	53.207	-2.553	1.00	40.02	CI	ATOM 2791	CB	ARG	423	41.098	54.943	0.312	1.00	24.39	CI
ATOM 2756	C	LEU	419	36.102	54.041	1.047	1.00	32.33	CI	ATOM 2792	CG	ARG	423	40.167	55.366	-0.807	1.00	22.81	CI
ATOM 2757	O	LEU	419	37.198	53.973	0.549	1.00	31.60	CI	ATOM 2793	CD	ARG	423	40.525	54.798	-2.172	1.00	25.55	CI
ATOM 2758	N	GLU	420	35.974	54.483	2.273	1.00	31.92	CI	ATOM 2794	NE	ARG	423	39.707	55.387	-3.216	1.00	25.38	CI
ATOM 2759	H	GLU	420	35.068	54.528	2.648	1.00	0.00	CI	ATOM 2795	HE	ARG	423	39.168	56.173	-2.989	1.00	0.00	CI
ATOM 2760	CA	GLU	420	37.078	54.905	3.092	1.00	31.79	CI	ATOM 2796	CZ	ARG	423	39.629	54.928	-4.466	1.00	27.32	CI
ATOM 2761	CB	GLU	420	36.477	55.462	4.344	1.00	34.29	CI	ATOM 2797	NH1	ARG	423	40.264	53.857	-4.949	1.00	26.37	CI
ATOM 2762	CG	GLU	420	37.430	56.240	5.185	1.00	38.66	CI	ATOM 2798	HH11	ARG	423	40.884	53.341	-4.365	1.00	0.00	CI
ATOM 2763	CD	GLU	420	36.952	56.499	6.609	1.00	45.20	CI	ATOM 2799	HH12	ARG	423	40.150	53.595	-5.907	1.00	0.00	CI
ATOM 2764	OE1	GLU	420	37.873	56.849	7.367	1.00	45.67	CI	ATOM 2800	NH2	ARG	423	38.960	55.682	-5.325	1.00	30.38	CI
ATOM 2765	OE2	GLU	420	35.745	56.345	6.954	1.00	44.21	CI	ATOM 2801	HH21	ARG	423	38.539	56.537	-5.023	1.00	0.00	CI
ATOM 2766	C	GLU	420	38.043	53.763	3.423	1.00	31.87	CI	ATOM 2802	HH22	ARG	423	38.865	55.385	-6.275	1.00	0.00	CI
ATOM 2767	O	GLU	420	39.253	53.949	3.270	1.00	32.82	CI	ATOM 2803	C	ARG	423	42.429	53.241	1.432	1.00	23.60	CI
ATOM 2768	N	GLN	421	37.553	52.624	3.954	1.00	30.46	CI	ATOM 2804	O	ARG	423	43.594	53.147	1.127	1.00	24.37	CI
ATOM 2769	H	GLN	421	36.583	52.556	4.098	1.00	0.00	CI	ATOM 2805	N	LYS	424	42.065	53.050	2.668	1.00	24.38	CI
ATOM 2770	CA	GLN	421	38.366	51.461	4.283	1.00	29.34	CI	ATOM 2806	H	LYS	424	41.109	53.051	2.890	1.00	0.00	CI

FIG. 5NN

ATOM 2807	CA	LYS	424	43.043	52.855	3.722	1.00	25.12	ATOM 2843	O	GLY	427	49.597	51.921	1.106	1.00	22.28	C1
ATOM 2808	CB	LYS	424	42.352	52.791	5.051	1.00	23.89	ATOM 2844	N	ASP	428	48.107	51.073	2.575	1.00	22.75	C1
ATOM 2809	CG	LYS	424	43.312	52.936	6.190	1.00	28.56	ATOM 2845	H	ASP	428	47.189	51.111	2.918	1.00	0.00	C1
ATOM 2810	CD	LYS	424	42.579	52.580	7.486	1.00	35.51	ATOM 2846	CA	ASP	428	49.039	50.108	3.131	1.00	23.87	C1
ATOM 2811	CE	LYS	424	41.338	53.425	7.853	1.00	40.33	ATOM 2847	CB	ASP	428	48.415	49.199	4.117	1.00	26.52	C1
ATOM 2812	NZ	LYS	424	40.519	52.722	8.834	1.00	42.23	ATOM 2848	CG	ASP	428	47.437	49.779	5.097	1.00	28.84	C1
ATOM 2813	HZ1	LYS	424	41.079	52.559	9.695	1.00	0.00	ATOM 2849	OD1	ASP	428	46.420	49.151	5.265	1.00	31.81	C1
ATOM 2814	HZ2	LYS	424	40.208	51.814	8.435	1.00	0.00	ATOM 2850	OD2	ASP	428	47.662	50.804	5.716	1.00	30.77	C1
ATOM 2815	HZ3	LYS	424	39.689	53.306	9.065	1.00	0.00	ATOM 2851	C	ASP	428	49.626	49.191	2.063	1.00	24.16	C1
ATOM 2816	C	LYS	424	43.761	51.547	3.462	1.00	27.10	ATOM 2852	O	ASP	428	50.812	48.896	2.088	1.00	26.17	C1
ATOM 2817	O	LYS	424	44.923	51.425	3.848	1.00	30.64	ATOM 2853	N	GLY	429	48.840	48.822	1.069	1.00	23.01	C1
ATOM 2818	N	ILE	425	43.190	50.542	2.794	1.00	26.83	ATOM 2854	H	GLY	429	47.905	49.113	1.071	1.00	0.00	C1
ATOM 2819	H	ILE	425	42.260	50.607	2.488	1.00	0.00	ATOM 2855	CA	GLY	429	49.289	47.964	0.029	1.00	25.44	C1
ATOM 2820	CA	ILE	425	43.949	49.312	2.561	1.00	25.46	ATOM 2856	C	GLY	429	50.405	48.649	-0.716	1.00	27.39	C1
ATOM 2821	CB	ILE	425	42.965	48.093	2.336	1.00	24.91	ATOM 2857	O	GLY	429	51.528	48.135	-0.741	1.00	28.51	C1
ATOM 2822	CG	ILE	425	43.654	46.786	1.995	1.00	22.01	ATOM 2858	N	ALA	430	50.127	49.840	-1.271	1.00	28.26	C1
ATOM 2823	CG	ILE	425	42.229	47.909	3.633	1.00	25.34	ATOM 2859	H	ALA	430	49.216	50.185	-1.172	1.00	0.00	C1
ATOM 2824	CD	ILE	425	40.885	47.169	3.432	1.00	25.68	ATOM 2860	CA	ALA	430	51.094	50.643	-2.015	1.00	26.04	C1
ATOM 2825	C	ILE	425	44.824	49.549	1.346	1.00	23.84	ATOM 2861	CB	ALA	430	50.490	51.976	-2.407	1.00	27.93	C1
ATOM 2826	O	ILE	425	45.959	49.069	1.316	1.00	24.57	ATOM 2862	C	ALA	430	52.300	50.927	-1.133	1.00	25.19	C1
ATOM 2827	N	GLN	426	44.361	50.267	0.323	1.00	23.28	ATOM 2863	O	ALA	430	53.393	51.053	-1.655	1.00	25.43	C1
ATOM 2828	H	GLN	426	43.451	50.630	0.393	1.00	0.00	ATOM 2864	N	ALA	431	52.171	50.979	0.186	1.00	24.05	C1
ATOM 2829	CA	GLN	426	45.164	50.531	-0.871	1.00	24.13	ATOM 2865	H	ALA	431	51.279	50.872	0.579	1.00	0.00	C1
ATOM 2830	CB	GLN	426	44.421	51.344	-1.896	1.00	24.04	ATOM 2866	CA	ALA	431	53.295	51.213	1.035	1.00	26.29	C1
ATOM 2831	CG	GLN	426	43.275	50.539	-2.396	1.00	23.56	ATOM 2867	CB	ALA	431	52.874	51.522	2.458	1.00	24.14	C1
ATOM 2832	CD	GLN	426	42.446	51.105	-3.511	1.00	23.92	ATOM 2868	C	ALA	431	54.139	49.972	1.073	1.00	29.82	C1
ATOM 2833	OE1	GLN	426	41.704	52.047	-3.345	1.00	25.34	ATOM 2869	O	ALA	431	55.360	50.085	0.959	1.00	31.97	C1
ATOM 2834	NE2	GLN	426	42.337	50.509	-4.672	1.00	27.55	ATOM 2870	N	LEU	432	53.562	48.777	1.203	1.00	31.87	C1
ATOM 2835	HE21	GLN	426	41.755	50.948	-5.323	1.00	0.00	ATOM 2871	H	LEU	432	52.585	48.726	1.279	1.00	0.00	C1
ATOM 2836	HE22	GLN	426	42.850	49.696	-4.851	1.00	0.00	ATOM 2872	CA	LEU	432	54.337	47.540	1.165	1.00	33.92	C1
ATOM 2837	C	GLN	426	46.404	51.312	-0.488	1.00	26.69	ATOM 2873	CB	LEU	432	53.430	46.315	1.301	1.00	37.42	C1
ATOM 2838	O	GLN	426	47.486	51.109	-1.046	1.00	29.73	ATOM 2874	CG	LEU	432	54.063	44.952	1.574	1.00	37.40	C1
ATOM 2839	N	GLY	427	46.300	52.204	0.499	1.00	26.49	ATOM 2875	CD1	LEU	432	54.751	44.949	2.950	1.00	38.10	C1
ATOM 2840	H	GLY	427	45.410	52.414	0.854	1.00	0.00	ATOM 2876	CD2	LEU	432	52.966	43.901	1.492	1.00	36.27	C1
ATOM 2841	CA	GLY	427	47.446	52.894	1.022	1.00	24.25	ATOM 2877	C	LEU	432	55.096	47.404	-0.146	1.00	33.74	C1
ATOM 2842	C	GLY	427	48.467	51.913	1.589	1.00	23.08	ATOM 2878	O	LEU	432	56.306	47.179	-0.138	1.00	33.29	C1

FIG. 500

ATOM 2879	N	GLN	433	54.402	47.564	-1.276	1.00	34.57	CI	ATOM	2915	H	LEU	436	58.235	47.245	-0.651	1.00	0.00	CI
ATOM 2880	H	GLN	433	53.439	47.733	-1.186	1.00	0.00	CI	ATOM	2916	CA	LEU	436	59.793	45.994	-1.304	1.00	34.25	CI
ATOM 2881	CA	GLN	433	55.002	47.526	-2.600	1.00	35.83	CI	ATOM	2917	CB	LEU	436	58.655	45.076	-1.753	1.00	33.41	CI
ATOM 2882	CB	GLN	433	53.999	47.892	-3.664	1.00	35.52	CI	ATOM	2918	CG	LEU	436	57.920	44.327	-0.610	1.00	34.72	CI
ATOM 2883	CG	GLN	433	52.996	46.823	-3.832	1.00	39.40	CI	ATOM	2919	CD1	LEU	436	56.764	43.538	-1.181	1.00	33.50	CI
ATOM 2884	CD	GLN	433	52.049	47.097	-4.973	1.00	42.46	CI	ATOM	2920	CD2	LEU	436	58.880	43.375	0.117	1.00	36.39	CI
ATOM 2885	OE1	GLN	433	50.924	47.526	-4.786	1.00	48.22	CI	ATOM	2921	C	LEU	436	60.669	46.383	-2.467	1.00	33.31	CI
ATOM 2886	NE2	GLN	433	52.376	46.878	-6.225	1.00	44.77	CI	ATOM	2922	O	LEU	436	61.756	45.825	-2.647	1.00	33.94	CI
ATOM 2887	HE21	GLN	433	53.271	46.540	-6.433	1.00	0.00	CI	ATOM	2923	N	CYS	437	60.220	47.374	-3.222	1.00	32.34	CI
ATOM 2888	HE22	GLN	433	51.693	47.087	-6.892	1.00	0.00	CI	ATOM	2924	H	CYS	437	59.290	47.661	-3.097	1.00	0.00	CI
ATOM 2889	C	GLN	433	56.177	48.485	-2.757	1.00	36.48	CI	ATOM	2925	CA	CYS	437	60.978	47.949	-4.301	1.00	32.01	CI
ATOM 2890	O	GLN	433	57.214	48.118	-3.312	1.00	38.08	CI	ATOM	2926	C	CYS	437	62.214	48.704	-3.857	1.00	34.70	CI
ATOM 2891	N	GLU	434	56.055	49.719	-2.287	1.00	36.11	CI	ATOM	2927	O	CYS	437	63.313	48.599	-4.412	1.00	36.26	CI
ATOM 2892	H	GLU	434	55.210	49.978	-1.854	1.00	0.00	CI	ATOM	2928	CB	CYS	437	60.094	48.840	-5.008	1.00	30.97	CI
ATOM 2893	CA	GLU	434	57.089	50.719	-2.426	1.00	35.93	CI	ATOM	2929	SG	CYS	437	61.003	49.666	-6.319	1.00	36.22	CI
ATOM 2894	CB	GLU	434	56.408	52.030	-2.068	1.00	41.28	CI	ATOM	2930	N	ALA	438	62.016	49.463	-2.785	1.00	36.35	CI
ATOM 2895	CG	GLU	434	57.126	53.356	-2.019	1.00	43.07	CI	ATOM	2931	H	ALA	438	61.108	49.547	-2.431	1.00	0.00	CI
ATOM 2896	CD	GLU	434	57.832	53.516	-0.698	1.00	45.70	CI	ATOM	2932	CA	ALA	438	63.060	50.226	-2.170	1.00	35.83	CI
ATOM 2897	OE1	GLU	434	57.190	53.538	0.367	1.00	49.33	CI	ATOM	2933	CB	ALA	438	62.440	51.107	-1.153	1.00	36.38	CI
ATOM 2898	OE2	GLU	434	59.051	53.579	-0.760	1.00	45.45	CI	ATOM	2934	C	ALA	438	64.065	49.294	-1.527	1.00	37.01	CI
ATOM 2899	C	GLU	434	58.257	50.348	-1.548	1.00	34.00	CI	ATOM	2935	O	ALA	438	65.132	49.168	-2.092	1.00	39.39	CI
ATOM 2900	O	GLU	434	59.388	50.481	-1.983	1.00	32.93	CI	ATOM	2936	N	THR	439	63.808	48.591	-0.422	1.00	36.59	CI
ATOM 2901	N	LYS	435	58.067	49.860	-0.330	1.00	34.34	CI	ATOM	2937	H	THR	439	62.947	48.723	0.014	1.00	0.00	CI
ATOM 2902	H	LYS	435	57.146	49.837	0.014	1.00	0.00	CI	ATOM	2938	CA	THR	439	64.742	47.669	0.223	1.00	35.70	CI
ATOM 2903	CA	LYS	435	59.151	49.358	0.511	1.00	34.56	CI	ATOM	2939	CB	THR	439	64.073	47.042	1.400	1.00	35.34	CI
ATOM 2904	CB	LYS	435	58.577	49.010	1.847	1.00	33.89	CI	ATOM	2940	OG1	THR	439	63.323	48.048	2.040	1.00	38.31	CI
ATOM 2905	CG	LYS	435	58.357	50.231	2.709	1.00	36.71	CI	ATOM	2941	HG1	THR	439	62.419	47.999	1.706	1.00	0.00	CI
ATOM 2906	CD	LYS	435	58.244	49.748	4.137	1.00	40.31	CI	ATOM	2942	CG2	THR	439	65.039	46.479	2.369	1.00	36.50	CI
ATOM 2907	CE	LYS	435	58.293	50.861	5.213	1.00	45.32	CI	ATOM	2943	C	THR	439	65.331	46.517	-0.590	1.00	36.10	CI
ATOM 2908	NZ	LYS	435	58.494	50.325	6.575	1.00	47.31	CI	ATOM	2944	O	THR	439	66.448	46.093	-0.312	1.00	36.51	CI
ATOM 2909	HZ1	LYS	435	59.388	49.795	6.611	1.00	0.00	CI	ATOM	2945	N	TYR	440	64.603	45.917	-1.548	1.00	36.02	CI
ATOM 2910	HZ2	LYS	435	57.708	49.689	6.818	1.00	0.00	CI	ATOM	2946	H	TYR	440	63.751	46.319	-1.822	1.00	0.00	CI
ATOM 2911	HZ3	LYS	435	58.534	51.109	7.257	1.00	0.00	CI	ATOM	2947	CA	TYR	440	65.057	44.691	-2.198	1.00	34.28	CI
ATOM 2912	C	LYS	435	59.906	48.135	-0.065	1.00	36.10	CI	ATOM	2948	CB	TYR	440	64.175	43.480	-1.878	1.00	33.99	CI
ATOM 2913	O	LYS	435	61.139	48.036	-0.012	1.00	37.08	CI	ATOM	2949	CG	TYR	440	64.016	43.240	-0.397	1.00	34.14	CI
ATOM 2914	N	LEU	436	59.215	47.168	-0.665	1.00	36.28	CI	ATOM	2950	CD1	TYR	440	62.773	43.230	0.169	1.00	35.16	CI

FIG. 5PP

ATOM	2951	CE1 TYR	440	62.625	43.037	1.532	1.00	36.66	CI	ATOM	2987	SC CYS	443	61.938	48.345	-7.519	1.00	32.96	CI
ATOM	2952	CD2 TYR	440	65.126	43.064	0.385	1.00	37.83	CI	ATOM	2988	N HIS	444	58.649	45.260	-9.911	1.00	35.65	CI
ATOM	2953	CE2 TYR	440	64.992	42.881	1.752	1.00	39.02	CI	ATOM	2989	H HIS	444	59.147	44.445	-9.659	1.00	0.00	CI
ATOM	2954	CZ TYR	440	63.741	42.864	2.317	1.00	37.34	CI	ATOM	2990	CA HIS	444	57.662	45.172	-10.975	1.00	37.75	CI
ATOM	2955	OH TYR	440	63.637	42.649	3.678	1.00	37.56	CI	ATOM	2991	CB HIS	444	58.329	45.224	-12.330	1.00	37.09	CI
ATOM	2956	HH TYR	440	64.498	42.343	3.988	1.00	0.00	CI	ATOM	2992	CG HIS	444	59.149	46.476	-12.560	1.00	41.36	CI
ATOM	2957	C TYR	440	65.088	44.768	-3.681	1.00	34.07	CI	ATOM	2993	CD2 HIS	444	60.434	46.664	-12.075	1.00	41.40	CI
ATOM	2958	O TYR	440	65.598	43.823	-4.267	1.00	35.54	CI	ATOM	2994	ND1 HIS	444	58.811	47.563	-13.261	1.00	41.74	CI
ATOM	2959	N LYS	441	64.627	45.833	-4.330	1.00	33.18	CI	ATOM	2995	HD1 HIS	444	57.892	47.890	-13.410	1.00	0.00	CI
ATOM	2960	H LYS	441	64.345	46.623	-3.822	1.00	0.00	CI	ATOM	2996	CE1 HIS	444	59.850	48.372	-13.217	1.00	42.00	CI
ATOM	2961	CA LYS	441	64.595	45.957	-5.763	1.00	30.44	CI	ATOM	2997	NE2 HIS	444	60.817	47.832	-12.502	1.00	41.38	CI
ATOM	2962	CB LYS	441	65.983	45.759	-6.364	1.00	33.76	CI	ATOM	2998	HE2 HIS	444	61.690	48.248	-12.334	1.00	0.00	CI
ATOM	2963	CG LYS	441	66.729	47.080	-6.407	1.00	39.59	CI	ATOM	2999	C HIS	444	56.889	43.871	-10.878	1.00	40.10	CI
ATOM	2964	CD LYS	441	67.273	47.497	-5.045	1.00	47.69	CI	ATOM	3000	O HIS	444	57.461	42.867	-11.309	1.00	40.15	CI
ATOM	2965	CE LYS	441	67.503	49.028	-4.984	1.00	53.37	CI	ATOM	3001	N PRO	445	55.615	43.752	-10.406	1.00	42.06	CI
ATOM	2966	NZ LYS	441	66.267	49.780	-5.240	1.00	57.64	CI	ATOM	3002	CD PRO	445	54.738	44.836	-9.937	1.00	41.56	CI
ATOM	2967	HZ1 LYS	441	65.568	49.549	-4.506	1.00	0.00	CI	ATOM	3003	CA PRO	445	54.913	42.497	-10.276	1.00	40.90	CI
ATOM	2968	HZ2 LYS	441	65.885	49.525	-6.173	1.00	0.00	CI	ATOM	3004	CB PRO	445	53.569	42.882	-9.730	1.00	39.35	CI
ATOM	2969	HZ3 LYS	441	66.468	50.801	-5.219	1.00	0.00	CI	ATOM	3005	CG PRO	445	53.364	44.274	-10.215	1.00	39.35	CI
ATOM	2970	C LYS	441	63.629	45.015	-6.425	1.00	28.86	CI	ATOM	3006	C PRO	445	54.868	41.782	-11.600	1.00	42.18	CI
ATOM	2971	O LYS	441	63.791	44.688	-7.603	1.00	29.95	CI	ATOM	3007	O PRO	445	54.769	40.571	-11.569	1.00	45.69	CI
ATOM	2972	N LEU	442	62.556	44.601	-5.749	1.00	27.58	CI	ATOM	3008	N GLU	446	55.082	42.380	-12.769	1.00	41.64	CI
ATOM	2973	H LEU	442	62.392	44.924	-4.837	1.00	0.00	CI	ATOM	3009	H GLU	446	55.320	43.320	-12.761	1.00	0.00	CI
ATOM	2974	CA LEU	442	61.554	43.780	-6.402	1.00	28.82	CI	ATOM	3010	CA GLU	446	55.025	41.656	-14.029	1.00	42.05	CI
ATOM	2975	CB LEU	442	60.947	42.694	-5.466	1.00	26.98	CI	ATOM	3011	CB GLU	446	54.967	42.639	-15.183	1.00	47.06	CI
ATOM	2976	CG LEU	442	61.905	41.634	-4.847	1.00	27.75	CI	ATOM	3012	CG GLU	446	54.109	43.925	-14.992	1.00	56.71	CI
ATOM	2977	CD1 LEU	442	61.133	40.643	-4.009	1.00	24.29	CI	ATOM	3013	CD GLU	446	54.728	45.083	-14.162	1.00	62.28	CI
ATOM	2978	CD2 LEU	442	62.667	40.932	-5.963	1.00	19.72	CI	ATOM	3014	OE1 GLU	446	54.100	45.472	-13.178	1.00	66.26	CI
ATOM	2979	C LEU	442	60.575	44.892	-6.635	1.00	30.59	CI	ATOM	3015	OE2 GLU	446	55.818	45.604	-14.473	1.00	65.55	CI
ATOM	2980	O LEU	442	59.811	45.261	-5.741	1.00	32.36	CI	ATOM	3016	C GLU	446	56.237	40.722	-14.197	1.00	40.44	CI
ATOM	2981	N CYS	443	60.700	45.506	-7.804	1.00	32.15	CI	ATOM	3017	O GLU	446	56.186	39.708	-14.904	1.00	41.66	CI
ATOM	2982	H CYS	443	61.423	45.199	-8.389	1.00	0.00	CI	ATOM	3018	N GLU	447	57.360	40.995	-13.538	1.00	37.89	CI
ATOM	2983	CA CYS	443	59.866	46.645	-8.191	1.00	32.69	CI	ATOM	3019	H GLU	447	57.394	41.809	-12.999	1.00	0.00	CI
ATOM	2984	C CYS	443	58.807	46.380	-9.217	1.00	33.43	CI	ATOM	3020	CA GLU	447	58.519	40.096	-13.509	1.00	36.73	CI
ATOM	2985	O CYS	443	58.051	47.288	-9.465	1.00	34.10	CI	ATOM	3021	CB GLU	447	59.750	40.810	-12.976	1.00	34.60	CI
ATOM	2986	CB CYS	443	60.715	47.800	-8.743	1.00	30.74	CI	ATOM	3022	CG GLU	447	60.320	41.883	-13.850	1.00	35.27	CI

FIG. 500

ATOM 3023	CD	GLU	447	61.450	42.699	-13.197	1.00	36.14	C1	ATOM 3059	CD1	LEU	451	58.833	32.284	-8.653	1.00	59.12	C1
ATOM 3024	OE1	GLU	447	62.240	43.286	-13.939	1.00	37.31	C1	ATOM 3060	CD2	LEU	451	58.369	34.511	-7.751	1.00	58.27	C1
ATOM 3025	OE2	GLU	447	61.541	42.782	-11.970	1.00	32.80	C1	ATOM 3061	C	LEU	451	54.785	32.700	-9.280	1.00	55.96	C1
ATOM 3026	C	GLU	447	58.311	38.850	-12.599	1.00	36.31	C1	ATOM 3062	O	LEU	451	54.717	31.935	-8.319	1.00	53.74	C1
ATOM 3027	O	GLU	447	59.113	37.911	-12.592	1.00	36.33	C1	ATOM 3063	N	GLY	452	53.774	33.533	-9.522	1.00	57.52	C1
ATOM 3028	N	LEU	448	57.273	38.763	-11.769	1.00	33.81	C1	ATOM 3064	H	GLY	452	53.889	34.241	-10.191	1.00	0.00	C1
ATOM 3029	H	LEU	448	56.554	39.431	-11.802	1.00	0.00	C1	ATOM 3065	CA	GLY	452	52.567	33.515	-8.710	1.00	60.66	C1
ATOM 3030	CA	LEU	448	57.145	37.691	-10.839	1.00	31.88	C1	ATOM 3066	C	GLY	452	51.942	32.137	-8.772	1.00	63.64	C1
ATOM 3031	CB	LEU	448	57.080	38.299	-9.484	1.00	29.29	C1	ATOM 3067	O	GLY	452	51.476	31.593	-7.782	1.00	62.60	C1
ATOM 3032	CG	LEU	448	58.008	39.432	-9.140	1.00	29.81	C1	ATOM 3068	N	HIS	453	52.089	31.545	-9.969	1.00	68.46	C1
ATOM 3033	CD1	LEU	448	57.907	39.863	-7.684	1.00	26.02	C1	ATOM 3069	H	HIS	453	52.628	32.040	-10.618	1.00	0.00	C1
ATOM 3034	CD2	LEU	448	59.396	38.931	-9.392	1.00	31.13	C1	ATOM 3070	CA	HIS	453	51.606	30.205	-10.326	1.00	72.27	C1
ATOM 3035	C	LEU	448	55.863	36.977	-11.165	1.00	33.75	C1	ATOM 3071	CB	HIS	453	51.785	29.908	-11.828	1.00	73.84	C1
ATOM 3036	O	LEU	448	55.436	36.145	-10.382	1.00	33.96	C1	ATOM 3072	CG	HIS	453	51.421	31.061	-12.777	1.00	77.81	C1
ATOM 3037	N	VAL	449	55.166	37.233	-12.263	1.00	36.99	C1	ATOM 3073	CD2	HIS	453	50.599	32.148	-12.498	1.00	79.29	C1
ATOM 3038	H	VAL	449	55.580	37.800	-12.942	1.00	0.00	C1	ATOM 3074	ND1	HIS	453	51.886	31.244	-14.012	1.00	79.84	C1
ATOM 3039	CA	VAL	449	53.819	36.701	-12.472	1.00	41.46	C1	ATOM 3075	HD1	HIS	453	52.617	30.739	-14.425	1.00	0.00	C1
ATOM 3040	CB	VAL	449	53.157	37.546	-13.625	1.00	41.56	C1	ATOM 3076	CE1	HIS	453	51.385	32.382	-14.470	1.00	81.11	C1
ATOM 3041	CG1	VAL	449	54.002	37.614	-14.880	1.00	42.22	C1	ATOM 3077	NE2	HIS	453	50.613	32.923	-13.551	1.00	79.85	C1
ATOM 3042	CG2	VAL	449	51.921	36.858	-14.112	1.00	42.01	C1	ATOM 3078	HE2	HIS	453	50.230	33.825	-13.586	1.00	0.00	C1
ATOM 3043	C	VAL	449	53.760	35.192	-12.733	1.00	44.81	C1	ATOM 3079	C	HIS	453	52.454	29.235	-9.515	1.00	73.43	C1
ATOM 3044	O	VAL	449	52.866	34.469	-12.227	1.00	44.54	C1	ATOM 3080	O	HIS	453	51.875	28.531	-8.692	1.00	73.56	C1
ATOM 3045	N	LEU	450	54.716	34.669	-13.515	1.00	47.21	C1	ATOM 3081	N	SER	454	53.785	29.207	-9.651	1.00	74.64	C1
ATOM 3046	H	LEU	450	55.416	35.260	-13.870	1.00	0.00	C1	ATOM 3082	H	SER	454	54.214	29.739	-10.351	1.00	0.00	C1
ATOM 3047	CA	LEU	450	54.771	33.243	-13.781	1.00	50.57	C1	ATOM 3083	CA	SER	454	54.639	28.411	-8.765	1.00	77.07	C1
ATOM 3048	CB	LEU	450	55.942	32.894	-14.628	1.00	50.75	C1	ATOM 3084	CB	SER	454	56.123	28.762	-8.980	1.00	77.34	C1
ATOM 3049	CG	LEU	450	56.148	33.488	-15.994	1.00	52.39	C1	ATOM 3085	OG	SER	454	57.095	27.715	-9.124	1.00	75.28	C1
ATOM 3050	CD1	LEU	450	57.152	32.586	-16.673	1.00	53.05	C1	ATOM 3086	HG	SER	454	57.149	27.211	-8.306	1.00	0.00	C1
ATOM 3051	CD2	LEU	450	54.882	33.534	-16.833	1.00	54.10	C1	ATOM 3087	C	SER	454	54.332	28.608	-7.262	1.00	78.84	C1
ATOM 3052	C	LEU	450	54.911	32.468	-12.471	1.00	53.83	C1	ATOM 3088	O	SER	454	54.270	27.617	-6.535	1.00	80.57	C1
ATOM 3053	O	LEU	450	54.297	31.406	-12.266	1.00	55.62	C1	ATOM 3089	N	LEU	455	54.070	29.789	-6.693	1.00	79.72	C1
ATOM 3054	N	LEU	451	55.685	33.097	-11.575	1.00	55.46	C1	ATOM 3090	H	LEU	455	53.956	30.582	-7.250	1.00	0.00	C1
ATOM 3055	H	LEU	451	56.073	33.954	-11.849	1.00	0.00	C1	ATOM 3091	CA	LEU	455	53.849	29.915	-5.257	1.00	80.43	C1
ATOM 3056	CA	LEU	451	55.998	32.654	-10.223	1.00	56.01	C1	ATOM 3092	CB	LEU	455	54.085	31.347	-4.838	1.00	80.20	C1
ATOM 3057	CB	LEU	451	57.137	33.542	-9.731	1.00	55.80	C1	ATOM 3093	CG	LEU	455	55.389	31.981	-5.269	1.00	81.67	C1
ATOM 3058	CG	LEU	451	57.745	33.278	-8.394	1.00	56.96	C1	ATOM 3094	CD1	LEU	455	55.254	33.494	-5.419	1.00	81.36	C1

FIG. 5RR

ATOM 3095	CD2 LEU 455	56.431	31.579	-4.264	1.00	82.26	Cl	ATOM 3131	CZ3 TRP 459	39.630	36.538	-10.597	1.00	84.56	Cl
ATOM 3096	C LEU 455	52.438	29.510	-4.848	1.00	81.56	Cl	ATOM 3132	CH2 TRP 459	39.562	37.904	-10.852	1.00	84.83	Cl
ATOM 3097	O LEU 455	52.038	29.893	-3.741	1.00	82.22	Cl	ATOM 3133	C TRP 459	42.009	35.013	-6.827	1.00	77.31	Cl
ATOM 3098	N GLY 456	51.653	28.816	-5.708	1.00	81.89	Cl	ATOM 3134	O TRP 459	41.202	34.244	-7.376	1.00	76.38	Cl
ATOM 3099	H GLY 456	52.026	28.592	-6.584	1.00	0.00	Cl	ATOM 3135	N ALA 460	41.557	35.969	-6.020	1.00	76.81	Cl
ATOM 3100	CA GLY 456	50.269	28.361	-5.467	1.00	82.22	Cl	ATOM 3136	H ALA 460	42.187	36.640	-5.689	1.00	0.00	Cl
ATOM 3101	C GLY 456	49.220	29.386	-4.973	1.00	82.56	Cl	ATOM 3137	CA ALA 460	40.158	36.044	-5.613	1.00	76.44	Cl
ATOM 3102	O GLY 456	48.268	28.989	-4.276	1.00	82.38	Cl	ATOM 3138	CB ALA 460	40.072	36.724	-4.243	1.00	75.51	Cl
ATOM 3103	N ILE 457	49.342	30.697	-5.286	1.00	82.54	Cl	ATOM 3139	C ALA 460	39.237	36.784	-6.588	1.00	76.29	Cl
ATOM 3104	H ILE 457	50.075	30.942	-5.894	1.00	0.00	Cl	ATOM 3140	O ALA 460	39.449	37.976	-6.833	1.00	76.98	Cl
ATOM 3105	CA ILE 457	48.435	31.761	-4.824	1.00	81.63	Cl	ATOM 3141	N PRO 461	38.217	36.147	-7.187	1.00	76.26	Cl
ATOM 3106	CB ILE 457	49.110	33.157	-5.086	1.00	80.69	Cl	ATOM 3142	CD PRO 461	38.104	34.684	-7.245	1.00	75.88	Cl
ATOM 3107	CG2 ILE 457	48.218	34.305	-4.662	1.00	79.76	Cl	ATOM 3143	CA PRO 461	37.242	36.793	-8.068	1.00	75.46	Cl
ATOM 3108	CG1 ILE 457	50.369	33.275	-4.253	1.00	79.82	Cl	ATOM 3144	CB PRO 461	36.605	35.605	-8.755	1.00	75.71	Cl
ATOM 3109	CD ILE 457	51.506	33.868	-5.081	1.00	77.89	Cl	ATOM 3145	CG PRO 461	36.703	34.458	-7.767	1.00	75.60	Cl
ATOM 3110	C ILE 457	47.048	31.698	-5.472	1.00	81.70	Cl	ATOM 3146	C PRO 461	36.221	37.803	-7.545	1.00	75.72	Cl
ATOM 3111	O ILE 457	46.903	31.761	-6.700	1.00	82.57	Cl	ATOM 3147	O PRO 461	35.677	37.734	-6.440	1.00	73.66	Cl
ATOM 3112	N PRO 458	45.963	31.583	-4.705	1.00	81.40	Cl	ATOM 3148	N LEU 462	35.996	38.767	-8.449	1.00	77.19	Cl
ATOM 3113	CD PRO 458	45.959	31.225	-3.278	1.00	81.21	Cl	ATOM 3149	H LEU 462	36.516	38.723	-9.277	1.00	0.00	Cl
ATOM 3114	CA PRO 458	44.607	31.643	-5.264	1.00	80.74	Cl	ATOM 3150	CA LEU 462	35.069	39.891	-8.275	1.00	78.87	Cl
ATOM 3115	CB PRO 458	43.779	30.942	-4.157	1.00	81.12	Cl	ATOM 3151	CB LEU 462	35.674	40.984	-7.360	1.00	78.32	Cl
ATOM 3116	CG PRO 458	44.757	30.293	-3.173	1.00	80.47	Cl	ATOM 3152	CG LEU 462	34.786	41.959	-6.558	1.00	78.09	Cl
ATOM 3117	C PRO 458	44.120	33.063	-5.648	1.00	79.70	Cl	ATOM 3153	CD1 LEU 462	34.051	42.987	-7.406	1.00	78.32	Cl
ATOM 3118	O PRO 458	43.674	33.736	-4.718	1.00	80.10	Cl	ATOM 3154	CD2 LEU 462	33.767	41.092	-5.828	1.00	78.62	Cl
ATOM 3119	N TRP 459	44.171	33.662	-6.861	1.00	78.19	Cl	ATOM 3155	C LEU 462	34.701	40.565	-9.611	1.00	80.63	Cl
ATOM 3120	H TRP 459	44.614	33.185	-7.591	1.00	0.00	Cl	ATOM 3156	OT1 LEU 462	33.507	40.842	-9.808	1.00	81.74	Cl
ATOM 3121	CA TRP 459	43.543	34.986	-7.092	1.00	77.73	Cl	ATOM 3157	OT2 LEU 462	35.606	40.847	-10.417	1.00	81.39	Cl
ATOM 3122	CB TRP 459	43.802	35.428	-8.522	1.00	78.71	Cl	ATOM 3158	CB LEU 472	22.074	42.654	-1.426	1.00	62.24	C2
ATOM 3123	CG TRP 459	43.054	36.677	-9.017	1.00	81.37	Cl	ATOM 3159	CG LEU 472	22.278	44.145	-1.189	1.00	59.98	C2
ATOM 3124	CD2 TRP 459	41.802	36.771	-9.618	1.00	82.89	Cl	ATOM 3160	CD1 LEU 472	23.496	44.325	-0.328	1.00	59.13	C2
ATOM 3125	CE2 TRP 459	41.717	38.139	-9.883	1.00	84.21	Cl	ATOM 3161	CD2 LEU 472	22.501	44.883	-2.486	1.00	56.85	C2
ATOM 3126	CE3 TRP 459	40.738	35.960	-9.983	1.00	84.28	Cl	ATOM 3162	C LEU 472	23.504	40.625	-1.996	1.00	63.91	C2
ATOM 3127	CD1 TRP 459	43.661	37.899	-8.925	1.00	83.89	Cl	ATOM 3163	O LEU 472	23.738	39.874	-2.949	1.00	64.90	C2
ATOM 3128	NE1 TRP 459	42.828	38.765	-9.460	1.00	85.23	Cl	ATOM 3164	HT1 LEU 472	21.563	41.441	-3.595	1.00	0.00	C2
ATOM 3129	HE1 TRP 459	42.944	39.738	-9.483	1.00	0.00	Cl	ATOM 3165	HT2 LEU 472	23.091	41.291	-4.237	1.00	0.00	C2
ATOM 3130	CZ2 TRP 459	40.615	38.727	-10.494	1.00	84.17	Cl	ATOM 3166	N LEU 472	22.472	41.930	-3.693	1.00	64.29	C2

FIG. 5S

ATOM 3167	HT3 LEU 472	22.358	42.849	-4.160	1.00	0.00	C2	ATOM 3203	O SER 477	31.980	37.143	-0.068	1.00	51.41	C2
ATOM 3168	CA LEU 472	23.092	42.037	-2.386	1.00	63.85	C2	ATOM 3204	N GLN 478	31.037	37.788	-1.984	1.00	50.21	C2
ATOM 3169	N ALA 473	23.652	40.229	-0.733	1.00	63.02	C2	ATOM 3205	H GLN 478	30.222	38.056	-2.457	1.00	0.00	C2
ATOM 3170	H ALA 473	23.533	40.867	0.002	1.00	0.00	C2	ATOM 3206	CA GLN 478	32.307	37.697	-2.715	1.00	51.37	C2
ATOM 3171	CA ALA 473	24.023	38.881	-0.353	1.00	62.37	C2	ATOM 3207	CB GLN 478	32.064	37.929	-4.166	1.00	53.65	C2
ATOM 3172	CB ALA 473	22.870	37.939	-0.358	1.00	63.65	C2	ATOM 3208	CG GLN 478	31.983	36.570	-4.788	1.00	57.32	C2
ATOM 3173	C ALA 473	25.196	38.354	-1.126	1.00	62.01	C2	ATOM 3209	CD GLN 478	31.354	36.649	-6.160	1.00	60.47	C2
ATOM 3174	O ALA 473	26.301	38.651	-0.715	1.00	63.36	C2	ATOM 3210	OE1 GLN 478	31.999	36.504	-7.205	1.00	62.26	C2
ATOM 3175	N GLY 474	25.032	37.784	-2.306	1.00	61.43	C2	ATOM 3211	NE2 GLN 478	30.045	36.878	-6.167	1.00	62.16	C2
ATOM 3176	H GLY 474	24.148	37.818	-2.722	1.00	0.00	C2	ATOM 3212	HE21 GLN 478	29.569	36.972	-5.317	1.00	0.00	C2
ATOM 3177	CA GLY 474	26.101	37.137	-3.047	1.00	63.80	C2	ATOM 3213	HE22 GLN 478	29.641	36.928	-7.054	1.00	0.00	C2
ATOM 3178	C GLY 474	27.354	37.950	-3.356	1.00	65.13	C2	ATOM 3214	C GLN 478	33.398	38.670	-2.249	1.00	50.66	C2
ATOM 3179	O GLY 474	28.482	37.417	-3.257	1.00	66.24	C2	ATOM 3215	O GLN 478	34.584	38.314	-2.217	1.00	50.13	C2
ATOM 3180	N CYS 475	27.175	39.237	-3.757	1.00	64.88	C2	ATOM 3216	N LEU 479	33.045	39.909	-1.859	1.00	48.78	C2
ATOM 3181	H CYS 475	26.261	39.550	-3.885	1.00	0.00	C2	ATOM 3217	H LEU 479	32.131	40.223	-2.039	1.00	0.00	C2
ATOM 3182	CA CYS 475	28.308	40.127	-4.068	1.00	61.84	C2	ATOM 3218	CA LEU 479	34.015	40.800	-1.235	1.00	45.87	C2
ATOM 3183	CB CYS 475	27.925	41.413	-4.806	1.00	63.74	C2	ATOM 3219	CB LEU 479	33.434	42.141	-0.827	1.00	47.03	C2
ATOM 3184	SG CYS 475	29.494	42.075	-5.437	1.00	68.86	C2	ATOM 3220	CG LEU 479	32.853	43.083	-1.818	1.00	49.40	C2
ATOM 3185	C CYS 475	28.995	40.567	-2.795	1.00	57.30	C2	ATOM 3221	CD1 LEU 479	32.596	44.393	-1.078	1.00	48.15	C2
ATOM 3186	O CYS 475	30.214	40.449	-2.724	1.00	57.14	C2	ATOM 3222	CD2 LEU 479	33.779	43.258	-3.000	1.00	48.59	C2
ATOM 3187	N LEU 476	28.230	40.983	-1.779	1.00	53.29	C2	ATOM 3223	C LEU 479	34.505	40.146	0.056	1.00	42.13	C2
ATOM 3188	H LEU 476	27.264	41.024	-1.885	1.00	0.00	C2	ATOM 3224	O LEU 479	35.695	39.955	0.262	1.00	40.90	C2
ATOM 3189	CA LEU 476	28.797	41.315	-0.493	1.00	50.43	C2	ATOM 3225	N HIS 480	33.609	39.766	0.950	1.00	39.56	C2
ATOM 3190	CB LEU 476	27.719	41.723	0.523	1.00	45.68	C2	ATOM 3226	H HIS 480	32.658	39.935	0.763	1.00	0.00	C2
ATOM 3191	CG LEU 476	27.130	43.165	0.497	1.00	42.80	C2	ATOM 3227	CA HIS 480	33.979	39.108	2.179	1.00	37.81	C2
ATOM 3192	CD1 LEU 476	26.670	43.559	1.896	1.00	36.25	C2	ATOM 3228	CB HIS 480	32.742	38.714	2.922	1.00	34.29	C2
ATOM 3193	CD2 LEU 476	28.180	44.180	0.057	1.00	40.22	C2	ATOM 3229	CG HIS 480	33.094	38.241	4.309	1.00	33.82	C2
ATOM 3194	C LEU 476	29.546	40.108	0.042	1.00	50.42	C2	ATOM 3230	CD2 HIS 480	33.123	36.932	4.709	1.00	33.44	C2
ATOM 3195	O LEU 476	30.614	40.222	0.646	1.00	50.61	C2	ATOM 3231	ND1 HIS 480	33.450	38.995	5.344	1.00	34.27	C2
ATOM 3196	N SER 477	29.053	38.922	-0.270	1.00	50.62	C2	ATOM 3232	HD1 HIS 480	33.505	39.976	5.362	1.00	0.00	C2
ATOM 3197	H SER 477	28.196	38.860	-0.729	1.00	0.00	C2	ATOM 3233	CE1 HIS 480	33.706	38.223	6.365	1.00	33.80	C2
ATOM 3198	CA SER 477	29.721	37.712	0.125	1.00	51.41	C2	ATOM 3234	NE2 HIS 480	33.504	36.986	5.965	1.00	37.12	C2
ATOM 3199	CB SER 477	28.778	36.524	-0.051	1.00	53.45	C2	ATOM 3235	HE2 HIS 480	33.637	36.202	6.544	1.00	0.00	C2
ATOM 3200	CG SER 477	27.732	36.616	0.926	1.00	57.65	C2	ATOM 3236	C HIS 480	34.836	37.860	1.961	1.00	39.08	C2
ATOM 3201	HG SER 477	27.280	37.462	0.828	1.00	0.00	C2	ATOM 3237	O HIS 480	35.716	37.631	2.791	1.00	40.93	C2
ATOM 3202	C SER 477	30.978	37.525	-0.681	1.00	50.75	C2	ATOM 3238	N SER 481	34.615	37.029	0.935	1.00	39.24	C2

FIG. 5TT

ATOM 3239	H SER 481	33.900	37.241	0.305	1.00	0.00	C2	ATOM 3275	CB LEU 485	41.183	34.629	-0.305	1.00	35.35	C2
ATOM 3240	CA SER 481	35.391	35.818	0.683	1.00	38.17	C2	ATOM 3276	CG LEU 485	42.101	33.962	-1.275	1.00	37.80	C2
ATOM 3241	CB SER 481	34.813	34.943	-0.420	1.00	40.42	C2	ATOM 3277	CD1 LEU 485	41.181	33.404	-2.345	1.00	41.44	C2
ATOM 3242	OG SER 481	33.454	34.597	-0.137	1.00	47.61	C2	ATOM 3278	CD2 LEU 485	43.125	34.903	-1.899	1.00	40.07	C2
ATOM 3243	HG SER 481	32.898	35.385	-0.162	1.00	0.00	C2	ATOM 3279	C LEU 485	42.740	35.585	1.376	1.00	33.95	C2
ATOM 3244	C SER 481	36.724	36.272	0.211	1.00	36.12	C2	ATOM 3280	O LEU 485	43.766	35.060	1.850	1.00	33.84	C2
ATOM 3245	O SER 481	37.692	35.793	0.765	1.00	36.23	C2	ATOM 3281	N TYR 486	42.609	36.885	1.034	1.00	33.67	C2
ATOM 3246	N GLY 482	36.786	37.206	-0.744	1.00	36.21	C2	ATOM 3282	H TYR 486	41.757	37.186	0.659	1.00	0.00	C2
ATOM 3247	H GLY 482	35.956	37.498	-1.168	1.00	0.00	C2	ATOM 3283	CA TYR 486	43.662	37.862	1.242	1.00	31.33	C2
ATOM 3248	CA GLY 482	38.028	37.792	-1.266	1.00	36.50	C2	ATOM 3284	CB TYR 486	43.210	39.290	0.714	1.00	35.33	C2
ATOM 3249	C GLY 482	38.958	38.296	-0.151	1.00	36.14	C2	ATOM 3285	CG TYR 486	43.300	39.325	-0.825	1.00	33.37	C2
ATOM 3250	O GLY 482	40.142	37.936	-0.055	1.00	36.65	C2	ATOM 3286	CD1 TYR 486	42.154	39.405	-1.579	1.00	32.79	C2
ATOM 3251	N LEU 483	38.381	39.084	0.750	1.00	34.04	C2	ATOM 3287	CE1 TYR 486	42.228	39.290	-2.944	1.00	33.73	C2
ATOM 3252	H LEU 483	37.445	39.326	0.608	1.00	0.00	C2	ATOM 3288	CD2 TYR 486	44.533	39.153	-1.445	1.00	34.59	C2
ATOM 3253	CA LEU 483	39.073	39.593	1.900	1.00	32.07	C2	ATOM 3289	CE2 TYR 486	44.618	39.033	-2.818	1.00	34.63	C2
ATOM 3254	CB LEU 483	38.134	40.442	2.731	1.00	31.17	C2	ATOM 3290	CZ TYR 486	43.451	39.096	-3.562	1.00	35.58	C2
ATOM 3255	CG LEU 483	37.535	41.687	2.081	1.00	31.11	C2	ATOM 3291	OH TYR 486	43.484	38.880	-4.942	1.00	38.24	C2
ATOM 3256	CD1 LEU 483	36.757	42.411	3.156	1.00	30.82	C2	ATOM 3292	HH TYR 486	42.614	39.086	-5.306	1.00	0.00	C2
ATOM 3257	CD2 LEU 483	38.599	42.593	1.480	1.00	29.50	C2	ATOM 3293	C TYR 486	44.068	37.905	2.697	1.00	27.39	C2
ATOM 3258	C LEU 483	39.600	38.461	2.745	1.00	32.91	C2	ATOM 3294	O TYR 486	45.258	38.007	2.942	1.00	26.06	C2
ATOM 3259	O LEU 483	40.752	38.498	3.199	1.00	31.25	C2	ATOM 3295	N GLN 487	43.270	37.691	3.708	1.00	26.95	C2
ATOM 3260	N PHE 484	38.767	37.422	2.925	1.00	34.08	C2	ATOM 3296	H GLN 487	42.315	37.545	3.565	1.00	0.00	C2
ATOM 3261	H PHE 484	37.900	37.408	2.471	1.00	0.00	C2	ATOM 3297	CA GLN 487	43.835	37.646	5.031	1.00	28.33	C2
ATOM 3262	CA PHE 484	39.105	36.298	3.788	1.00	34.60	C2	ATOM 3298	CB GLN 487	42.690	37.578	6.050	1.00	32.66	C2
ATOM 3263	CB PHE 484	37.975	35.300	3.925	1.00	37.46	C2	ATOM 3299	CG GLN 487	43.092	37.979	7.485	1.00	37.50	C2
ATOM 3264	CG PHE 484	38.268	34.183	4.897	1.00	40.86	C2	ATOM 3300	CD GLN 487	43.966	39.252	7.469	1.00	40.54	C2
ATOM 3265	CD1 PHE 484	38.219	32.884	4.482	1.00	45.62	C2	ATOM 3301	OE1 GLN 487	43.441	40.346	7.292	1.00	40.45	C2
ATOM 3266	CD2 PHE 484	38.528	34.445	6.210	1.00	43.62	C2	ATOM 3302	NE2 GLN 487	45.305	39.206	7.549	1.00	38.19	C2
ATOM 3267	CE1 PHE 484	38.421	31.858	5.395	1.00	47.98	C2	ATOM 3303	HE21 GLN 487	45.755	40.057	7.452	1.00	0.00	C2
ATOM 3268	CE2 PHE 484	38.731	33.427	7.119	1.00	46.78	C2	ATOM 3304	HE22 GLN 487	45.736	38.340	7.702	1.00	0.00	C2
ATOM 3269	CZ PHE 484	38.677	32.119	6.720	1.00	48.06	C2	ATOM 3305	C GLN 487	44.791	36.455	5.207	1.00	28.53	C2
ATOM 3270	C PHE 484	40.245	35.602	3.113	1.00	33.92	C2	ATOM 3306	O GLN 487	45.774	36.542	5.964	1.00	28.72	C2
ATOM 3271	O PHE 484	41.162	35.289	3.826	1.00	34.25	C2	ATOM 3307	N GLY 488	44.550	35.363	4.454	1.00	28.32	C2
ATOM 3272	N LEU 485	40.326	35.413	1.799	1.00	32.75	C2	ATOM 3308	H GLY 488	43.799	35.400	3.824	1.00	0.00	C2
ATOM 3273	H LEU 485	39.577	35.717	1.250	1.00	0.00	C2	ATOM 3309	CA GLY 488	45.291	34.120	4.557	1.00	26.04	C2
ATOM 3274	CA LEU 485	41.475	34.778	1.163	1.00	33.74	C2	ATOM 3310	C GLY 488	46.660	34.264	4.033	1.00	25.75	C2

FIG. 50U

ATOM 3311	O	GLY	488	47.660	33.946	4.712	1.00	25.86	ATOM 3347	O	ALA	492	53.789	32.943	4.879	1.00	36.03	C2
ATOM 3312	N	LEU	489	46.655	34.798	2.818	1.00	25.05	ATOM 3348	N	LEU	493	52.885	34.981	4.728	1.00	35.94	C2
ATOM 3313	H	LEU	489	45.798	35.062	2.416	1.00	0.00	ATOM 3349	H	LEU	493	52.060	35.510	4.721	1.00	0.00	C2
ATOM 3314	CA	LEU	489	47.911	34.990	2.099	1.00	25.63	ATOM 3350	CA	LEU	493	54.139	35.634	4.426	1.00	34.86	C2
ATOM 3315	CB	LEU	489	47.708	35.570	0.725	1.00	27.66	ATOM 3351	CB	LEU	493	53.898	36.990	3.747	1.00	31.36	C2
ATOM 3316	CG	LEU	489	46.761	34.755	-0.189	1.00	30.83	ATOM 3352	CG	LEU	493	53.127	37.065	2.443	1.00	28.27	C2
ATOM 3317	CD1	LEU	489	46.373	35.506	-1.471	1.00	30.43	ATOM 3353	CD1	LEU	493	52.715	38.495	2.214	1.00	31.74	C2
ATOM 3318	CD2	LEU	489	47.472	33.454	-0.502	1.00	32.62	ATOM 3354	CD2	LEU	493	53.977	36.608	1.285	1.00	28.79	C2
ATOM 3319	C	LEU	489	48.783	35.936	2.853	1.00	25.28	ATOM 3355	C	LEU	493	54.879	35.843	5.721	1.00	36.15	C2
ATOM 3320	O	LEU	489	49.973	35.705	2.914	1.00	27.37	ATOM 3356	O	LEU	493	55.985	36.374	5.694	1.00	36.70	C2
ATOM 3321	N	LEU	490	48.237	36.935	3.534	1.00	25.79	ATOM 3357	N	GLU	494	54.300	35.497	6.855	1.00	38.35	C2
ATOM 3322	H	LEU	490	47.267	37.079	3.515	1.00	0.00	ATOM 3358	H	GLU	494	53.395	35.130	6.836	1.00	0.00	C2
ATOM 3323	CA	LEU	490	49.072	37.868	4.220	1.00	25.96	ATOM 3359	CA	GLU	494	54.910	35.648	8.157	1.00	43.14	C2
ATOM 3324	CB	LEU	490	48.274	39.139	4.567	1.00	27.96	ATOM 3360	CB	GLU	494	55.621	34.340	8.545	1.00	46.61	C2
ATOM 3325	CG	LEU	490	47.823	40.131	3.474	1.00	27.89	ATOM 3361	CG	GLU	494	54.711	33.471	9.419	1.00	53.71	C2
ATOM 3326	CD1	LEU	490	46.772	41.019	4.123	1.00	28.03	ATOM 3362	CD	GLU	494	54.195	32.160	8.785	1.00	60.27	C2
ATOM 3327	CD2	LEU	490	48.988	40.942	4.899	1.00	28.15	ATOM 3363	OE1	GLU	494	53.146	31.653	9.230	1.00	63.52	C2
ATOM 3328	C	LEU	490	49.619	37.243	5.459	1.00	27.33	ATOM 3364	OE2	GLU	494	54.839	31.630	7.862	1.00	62.76	C2
ATOM 3329	O	LEU	490	50.740	37.528	5.865	1.00	26.73	ATOM 3365	C	GLU	494	55.865	36.825	8.343	1.00	44.32	C2
ATOM 3330	N	GLN	491	48.883	36.370	6.111	1.00	29.88	ATOM 3366	O	GLU	494	57.055	36.678	8.610	1.00	46.91	C2
ATOM 3331	H	GLN	491	47.984	36.127	5.799	1.00	0.00	ATOM 3367	N	GLY	495	55.358	38.046	8.114	1.00	44.32	C2
ATOM 3332	CA	GLN	491	49.430	35.809	7.314	1.00	33.01	ATOM 3368	H	GLY	495	54.450	38.112	7.753	1.00	0.00	C2
ATOM 3333	CB	GLN	491	48.305	35.113	8.027	1.00	38.68	ATOM 3369	CA	GLY	495	56.104	39.272	8.368	1.00	42.36	C2
ATOM 3334	CG	GLN	491	47.856	35.963	9.197	1.00	46.07	ATOM 3370	C	GLY	495	57.015	39.695	7.238	1.00	42.33	C2
ATOM 3335	CD	GLN	491	46.348	36.262	9.278	1.00	50.83	ATOM 3371	O	GLY	495	57.397	40.866	7.220	1.00	42.42	C2
ATOM 3336	OE1	GLN	491	45.965	37.436	9.402	1.00	51.92	ATOM 3372	N	ILE	496	57.310	38.802	6.279	1.00	41.04	C2
ATOM 3337	NE2	GLN	491	45.425	35.294	9.278	1.00	51.67	ATOM 3373	H	ILE	496	56.927	37.906	6.374	1.00	0.00	C2
ATOM 3338	HE21	GLN	491	45.723	34.353	9.288	1.00	0.00	ATOM 3374	CA	ILE	496	58.259	38.993	5.192	1.00	41.15	C2
ATOM 3339	HE22	GLN	491	44.489	35.560	9.286	1.00	0.00	ATOM 3375	CB	ILE	496	57.929	40.216	4.253	1.00	38.60	C2
ATOM 3340	C	GLN	491	50.582	34.867	6.986	1.00	33.58	ATOM 3376	CG2	ILE	496	59.077	40.437	3.248	1.00	37.62	C2
ATOM 3341	O	GLN	491	51.582	34.828	7.715	1.00	34.65	ATOM 3377	CG1	ILE	496	56.662	39.964	3.480	1.00	36.39	C2
ATOM 3342	N	ALA	492	50.482	34.191	5.824	1.00	34.15	ATOM 3378	CD	ILE	496	56.314	41.071	2.470	1.00	35.27	C2
ATOM 3343	H	ALA	492	49.701	34.382	5.264	1.00	0.00	ATOM 3379	C	ILE	496	59.672	39.203	5.749	1.00	42.91	C2
ATOM 3344	CA	ALA	492	51.416	33.177	5.321	1.00	33.64	ATOM 3380	O	ILE	496	60.541	38.396	5.448	1.00	44.22	C2
ATOM 3345	CB	ALA	492	50.818	32.500	4.081	1.00	31.67	ATOM 3381	N	SER	497	59.998	40.228	6.533	1.00	44.31	C2
ATOM 3346	C	ALA	492	52.802	33.678	4.959	1.00	34.79	ATOM 3382	H	SER	497	59.297	40.852	6.827	1.00	0.00	C2

FIG. 5W

ATOM 3383	CA SER 497	61.346	40.501	6.992	1.00	44.86	ATOM 3419	O GLY 501	54.661	44.034	9.777	1.00	40.66	C2
ATOM 3384	CB SER 497	62.204	41.254	5.938	1.00	44.13	ATOM 3420	N PRO 502	55.986	45.462	10.742	1.00	39.90	C2
ATOM 3385	OC SER 497	62.181	42.673	6.033	1.00	40.74	ATOM 3421	CA PRO 502	57.227	45.908	11.335	1.00	41.18	C2
ATOM 3386	HG SER 497	62.531	42.964	5.170	1.00	0.00	ATOM 3422	CD PRO 502	54.912	46.387	11.045	1.00	38.67	C2
ATOM 3387	C SER 497	61.164	41.413	8.185	1.00	45.85	ATOM 3423	CB PRO 502	55.594	47.494	11.791	1.00	39.23	C2
ATOM 3388	O SER 497	60.132	42.110	8.288	1.00	47.55	ATOM 3424	CG PRO 502	56.989	47.405	11.221	1.00	41.36	C2
ATOM 3389	N PRO 498	62.164	41.490	9.071	1.00	44.96	ATOM 3425	C PRO 502	54.158	46.849	9.817	1.00	37.54	C2
ATOM 3390	CD PRO 498	63.338	40.621	9.126	1.00	42.33	ATOM 3426	O PRO 502	52.966	47.139	9.961	1.00	38.36	C2
ATOM 3391	CA PRO 498	62.086	42.327	10.250	1.00	44.88	ATOM 3427	N THR 503	54.728	46.887	8.609	1.00	35.13	C2
ATOM 3392	CB PRO 498	63.431	42.038	10.885	1.00	45.13	ATOM 3428	H THR 503	55.663	46.638	8.449	1.00	0.00	C2
ATOM 3393	CG PRO 498	63.629	40.581	10.603	1.00	42.00	ATOM 3429	CA THR 503	53.940	47.283	7.462	1.00	35.09	C2
ATOM 3394	C PRO 498	61.760	43.799	9.983	1.00	45.22	ATOM 3430	CB THR 503	54.832	47.376	6.245	1.00	34.48	C2
ATOM 3395	O PRO 498	61.215	44.446	10.869	1.00	45.24	ATOM 3431	OG1 THR 503	56.025	48.018	6.668	1.00	38.23	C2
ATOM 3396	N GLU 499	62.017	44.314	8.777	1.00	46.16	ATOM 3432	HG1 THR 503	55.857	48.946	6.845	1.00	0.00	C2
ATOM 3397	H GLU 499	62.362	43.716	8.081	1.00	0.00	ATOM 3433	CG2 THR 503	54.197	48.162	5.126	1.00	35.56	C2
ATOM 3398	CA GLU 499	61.731	45.699	8.391	1.00	48.06	ATOM 3434	C THR 503	52.836	46.252	7.215	1.00	35.37	C2
ATOM 3399	CB GLU 499	62.498	46.193	7.155	1.00	52.19	ATOM 3435	O THR 503	51.671	46.552	6.915	1.00	37.11	C2
ATOM 3400	CG GLU 499	64.001	46.187	7.100	1.00	57.51	ATOM 3436	N LEU 504	53.218	44.996	7.380	1.00	34.02	C2
ATOM 3401	CD GLU 499	64.544	44.777	7.076	1.00	60.61	ATOM 3437	H LEU 504	54.146	44.799	7.647	1.00	0.00	C2
ATOM 3402	OE1 GLU 499	64.755	44.231	8.162	1.00	62.96	ATOM 3438	CA LEU 504	52.301	43.912	7.173	1.00	32.50	C2
ATOM 3403	OE2 GLU 499	64.739	44.234	5.984	1.00	62.79	ATOM 3439	CB LEU 504	53.127	42.650	7.002	1.00	34.78	C2
ATOM 3404	C GLU 499	60.269	45.896	7.981	1.00	46.94	ATOM 3440	CG LEU 504	53.464	42.256	5.601	1.00	34.07	C2
ATOM 3405	O GLU 499	59.600	46.895	8.272	1.00	48.15	ATOM 3441	CD1 LEU 504	54.163	40.977	5.667	1.00	37.97	C2
ATOM 3406	N LEU 500	59.806	44.934	7.193	1.00	44.38	ATOM 3442	CD2 LEU 504	52.254	41.865	4.809	1.00	37.34	C2
ATOM 3407	H LEU 500	60.351	44.137	7.027	1.00	0.00	ATOM 3443	C LEU 504	51.324	43.821	8.328	1.00	29.54	C2
ATOM 3408	CA LEU 500	58.491	44.997	6.651	1.00	41.08	ATOM 3444	O LEU 504	50.141	43.562	8.078	1.00	30.40	C2
ATOM 3409	CB LEU 500	58.519	44.197	5.445	1.00	41.37	ATOM 3445	N ASP 505	51.736	44.106	9.551	1.00	26.09	C2
ATOM 3410	CG LEU 500	59.303	44.862	4.351	1.00	42.70	ATOM 3446	H ASP 505	52.689	44.269	9.699	1.00	0.00	C2
ATOM 3411	CD1 LEU 500	59.776	43.828	3.351	1.00	43.98	ATOM 3447	CA ASP 505	50.798	44.084	10.643	1.00	27.88	C2
ATOM 3412	CD2 LEU 500	58.427	45.874	3.671	1.00	45.04	ATOM 3448	CB ASP 505	51.446	44.345	11.926	1.00	29.86	C2
ATOM 3413	C LEU 500	57.455	44.521	7.628	1.00	40.59	ATOM 3449	CG ASP 505	52.500	43.312	12.239	1.00	34.64	C2
ATOM 3414	O LEU 500	56.274	44.835	7.463	1.00	40.69	ATOM 3450	OD1 ASP 505	52.663	42.298	11.534	1.00	41.04	C2
ATOM 3415	N GLY 501	57.866	43.835	8.685	1.00	39.37	ATOM 3451	OD2 ASP 505	53.179	43.542	13.224	1.00	37.40	C2
ATOM 3416	H GLY 501	58.808	43.579	8.730	1.00	0.00	ATOM 3452	C ASP 505	49.661	45.060	10.568	1.00	28.61	C2
ATOM 3417	CA GLY 501	56.974	43.386	9.734	1.00	39.59	ATOM 3453	O ASP 505	48.566	44.739	11.039	1.00	30.30	C2
ATOM 3418	C GLY 501	55.816	44.324	10.092	1.00	39.66	ATOM 3454	N THR 506	49.894	46.242	10.002	1.00	28.29	C2

FIG. 5W

ATOM 3455 H THR 506	50.823	46.493	9.804	1.00	0.00	ATOM 3491 C LEU 509	43.465	45.471	10.130	1.00	25.17	C2
ATOM 3456 CA THR 506	48.860	47.225	9.731	1.00	25.74	ATOM 3492 O LEU 509	42.274	45.411	10.408	1.00	27.22	C2
ATOM 3457 CB THR 506	49.497	48.556	9.336	1.00	26.14	ATOM 3493 N ASP 510	43.899	46.208	9.101	1.00	23.77	C2
ATOM 3458 OG1 THR 506	49.944	49.099	10.588	1.00	31.63	ATOM 3494 H ASP 510	44.865	46.277	8.930	1.00	0.00	C2
ATOM 3459 HG1 THR 506	49.243	49.072	11.246	1.00	0.00	ATOM 3495 CA ASP 510	42.955	46.898	8.240	1.00	22.66	C2
ATOM 3460 CG2 THR 506	48.594	49.517	8.619	1.00	24.46	ATOM 3496 CB ASP 510	43.652	47.829	7.306	1.00	25.21	C2
ATOM 3461 C THR 506	48.022	46.735	8.615	1.00	24.00	ATOM 3497 CG ASP 510	44.316	48.966	8.068	1.00	33.01	C2
ATOM 3462 O THR 506	46.817	46.864	8.719	1.00	25.85	ATOM 3498 ODI ASP 510	45.178	49.621	7.477	1.00	34.28	C2
ATOM 3463 N LEU 507	48.554	46.196	7.525	1.00	23.51	ATOM 3499 OD2 ASP 510	43.988	49.209	9.250	1.00	34.44	C2
ATOM 3464 H LEU 507	49.527	46.073	7.453	1.00	0.00	ATOM 3500 C ASP 510	42.104	45.980	7.398	1.00	23.72	C2
ATOM 3465 CA LEU 507	47.682	45.770	6.434	1.00	23.85	ATOM 3501 O ASP 510	40.897	46.220	7.387	1.00	24.80	C2
ATOM 3466 CB LEU 507	48.574	45.408	5.196	1.00	23.33	ATOM 3502 N VAL 511	42.632	44.984	6.659	1.00	22.38	C2
ATOM 3467 CG LEU 507	48.010	44.919	3.858	1.00	20.85	ATOM 3503 H VAL 511	43.611	44.900	6.620	1.00	0.00	C2
ATOM 3468 CD1 LEU 507	46.771	45.650	3.455	1.00	24.13	ATOM 3504 CA VAL 511	41.823	44.010	5.961	1.00	21.89	C2
ATOM 3469 CD2 LEU 507	49.074	45.055	2.842	1.00	20.13	ATOM 3505 CB VAL 511	42.752	42.924	5.366	1.00	22.71	C2
ATOM 3470 C LEU 507	46.766	44.640	6.880	1.00	24.09	ATOM 3506 CG1 VAL 511	41.954	41.756	4.792	1.00	20.43	C2
ATOM 3471 O LEU 507	45.600	44.764	6.541	1.00	25.80	ATOM 3507 CG2 VAL 511	43.529	43.524	4.210	1.00	16.19	C2
ATOM 3472 N GLN 508	47.152	43.618	7.661	1.00	24.01	ATOM 3508 C VAL 511	40.827	43.403	6.960	1.00	21.92	C2
ATOM 3473 H GLN 508	48.112	43.555	7.866	1.00	0.00	ATOM 3509 O VAL 511	39.625	43.447	6.719	1.00	23.46	C2
ATOM 3474 CA GLN 508	46.228	42.625	8.214	1.00	23.71	ATOM 3510 N ALA 512	41.258	43.017	8.163	1.00	20.49	C2
ATOM 3475 CB GLN 508	46.961	41.627	9.036	1.00	23.83	ATOM 3511 H ALA 512	42.216	43.063	8.361	1.00	0.00	C2
ATOM 3476 CG GLN 508	47.937	40.899	8.173	1.00	31.64	ATOM 3512 CA ALA 512	40.388	42.357	9.108	1.00	20.83	C2
ATOM 3477 CD GLN 508	48.842	40.080	9.054	1.00	34.00	ATOM 3513 CB ALA 512	41.103	41.974	10.344	1.00	17.89	C2
ATOM 3478 OE1 GLN 508	50.031	40.346	9.161	1.00	38.32	ATOM 3514 C ALA 512	39.250	43.205	9.550	1.00	23.89	C2
ATOM 3479 NE2 GLN 508	48.321	39.090	9.748	1.00	36.30	ATOM 3515 O ALA 512	38.201	42.668	9.874	1.00	24.61	C2
ATOM 3480 HE21 GLN 508	47.373	38.880	9.639	1.00	0.00	ATOM 3516 N ASP 513	39.417	44.539	9.544	1.00	25.96	C2
ATOM 3481 HE22 GLN 508	48.891	38.636	10.406	1.00	0.00	ATOM 3517 H ASP 513	40.300	44.888	9.291	1.00	0.00	C2
ATOM 3482 C GLN 508	45.105	43.123	9.111	1.00	24.24	ATOM 3518 CA ASP 513	38.374	45.471	9.947	1.00	25.37	C2
ATOM 3483 O GLN 508	43.978	42.650	9.014	1.00	24.06	ATOM 3519 CB ASP 513	38.958	46.787	10.373	1.00	26.88	C2
ATOM 3484 N LEU 509	45.375	44.019	10.090	1.00	26.07	ATOM 3520 CG ASP 513	39.682	46.679	11.712	1.00	32.35	C2
ATOM 3485 H LEU 509	46.316	44.262	10.222	1.00	0.00	ATOM 3521 ODI ASP 513	40.371	47.644	12.058	1.00	35.06	C2
ATOM 3486 CA LEU 509	44.378	44.640	10.977	1.00	25.71	ATOM 3522 OD2 ASP 513	39.580	45.646	12.390	1.00	34.10	C2
ATOM 3487 CB LEU 509	44.993	45.555	12.031	1.00	25.60	ATOM 3523 C ASP 513	37.392	45.730	8.846	1.00	24.95	C2
ATOM 3488 CG LEU 509	45.838	44.757	13.042	1.00	29.00	ATOM 3524 O ASP 513	36.185	45.868	9.090	1.00	26.92	C2
ATOM 3489 CD1 LEU 509	46.658	45.705	13.886	1.00	28.93	ATOM 3525 N PHE 514	37.867	45.739	7.634	1.00	22.88	C2
ATOM 3490 CD2 LEU 509	44.950	43.919	13.937	1.00	27.94	ATOM 3526 H PHE 514	38.829	45.614	7.475	1.00	0.00	C2

FIG. 5XX

ATOM 3527	CA PHE 514	36.974	45.922	6.530	1.00	24.09	ATOM 3563	CA ILE 518	30.923	43.646	5.510	1.00	36.10	C2
ATOM 3528	CB PHE 514	37.812	46.061	5.266	1.00	18.11	ATOM 3564	CB ILE 518	31.699	42.912	4.439	1.00	33.81	C2
ATOM 3529	CG PHE 514	36.956	46.470	4.072	1.00	17.86	ATOM 3565	CG ILE 518	30.703	42.202	3.555	1.00	33.46	C2
ATOM 3530	CD1 PHE 514	35.715	47.089	4.245	1.00	15.18	ATOM 3566	CG ILE 518	32.623	43.842	3.699	1.00	32.91	C2
ATOM 3531	CD2 PHE 514	37.440	46.197	2.804	1.00	13.77	ATOM 3567	CD ILE 518	32.019	44.700	2.596	1.00	34.89	C2
ATOM 3532	CE1 PHE 514	34.983	47.419	3.130	1.00	14.53	ATOM 3568	C ILE 518	30.172	42.591	6.317	1.00	38.63	C2
ATOM 3533	CE2 PHE 514	36.693	46.539	1.705	1.00	12.10	ATOM 3569	O ILE 518	28.938	42.545	6.205	1.00	39.93	C2
ATOM 3534	CZ PHE 514	35.468	47.146	1.868	1.00	10.68	ATOM 3570	N TRP 519	30.842	41.785	7.179	1.00	38.64	C2
ATOM 3535	C PHE 514	36.026	44.703	6.450	1.00	29.23	ATOM 3571	H TRP 519	31.785	41.959	7.361	1.00	0.00	C2
ATOM 3536	O PHE 514	34.788	44.828	6.350	1.00	29.80	ATOM 3572	CA TRP 519	30.144	40.784	7.945	1.00	38.15	C2
ATOM 3537	N ALA 515	36.604	43.490	6.531	1.00	31.15	ATOM 3573	CB TRP 519	31.124	40.083	8.780	1.00	38.52	C2
ATOM 3538	H ALA 515	37.581	43.450	6.639	1.00	0.00	ATOM 3574	CG TRP 519	30.493	38.793	9.255	1.00	42.26	C2
ATOM 3539	CA ALA 515	35.839	42.260	6.416	1.00	32.36	ATOM 3575	CD2 TRP 519	29.880	38.578	10.473	1.00	41.70	C2
ATOM 3540	CB ALA 515	36.851	41.126	6.402	1.00	32.35	ATOM 3576	CE2 TRP 519	29.437	37.278	10.335	1.00	41.69	C2
ATOM 3541	C ALA 515	34.801	42.089	7.535	1.00	32.39	ATOM 3577	CE3 TRP 519	29.648	39.282	11.629	1.00	42.26	C2
ATOM 3542	O ALA 515	33.676	41.609	7.331	1.00	32.63	ATOM 3578	CD1 TRP 519	30.448	37.695	8.419	1.00	42.92	C2
ATOM 3543	N THR 516	35.164	42.457	8.735	1.00	33.01	ATOM 3579	NE1 TRP 519	29.788	36.793	9.115	1.00	44.19	C2
ATOM 3544	H THR 516	36.117	42.578	8.935	1.00	0.00	ATOM 3580	HE1 TRP 519	29.485	35.935	8.741	1.00	0.00	C2
ATOM 3545	CA THR 516	34.231	42.566	9.821	1.00	35.18	ATOM 3581	CZ2 TRP 519	28.753	36.671	11.360	1.00	41.91	C2
ATOM 3546	CB THR 516	35.016	43.018	10.988	1.00	35.40	ATOM 3582	CZ3 TRP 519	28.964	38.666	12.652	1.00	41.77	C2
ATOM 3547	OG1 THR 516	35.685	41.818	11.336	1.00	42.65	ATOM 3583	CH2 TRP 519	28.522	37.375	12.515	1.00	41.05	C2
ATOM 3548	HG1 THR 516	36.505	41.713	10.816	1.00	0.00	ATOM 3584	C TRP 519	29.027	41.368	8.815	1.00	39.33	C2
ATOM 3549	CG2 THR 516	34.262	43.672	12.097	1.00	35.56	ATOM 3585	O TRP 519	27.888	40.919	8.726	1.00	38.28	C2
ATOM 3550	C THR 516	33.140	43.554	9.482	1.00	37.62	ATOM 3586	N GLN 520	29.264	42.375	9.650	1.00	41.86	C2
ATOM 3551	O THR 516	32.005	43.315	9.857	1.00	40.37	ATOM 3587	H GLN 520	30.180	42.717	9.700	1.00	0.00	C2
ATOM 3552	N THR 517	33.387	44.666	8.802	1.00	38.61	ATOM 3588	CA GLN 520	28.240	43.016	10.464	1.00	44.63	C2
ATOM 3553	H THR 517	34.291	44.850	8.469	1.00	0.00	ATOM 3589	CB GLN 520	28.691	44.198	11.239	1.00	47.03	C2
ATOM 3554	CA THR 517	32.359	45.641	8.512	1.00	38.92	ATOM 3590	CG GLN 520	29.602	43.808	12.360	1.00	54.78	C2
ATOM 3555	CB THR 517	33.123	46.903	7.962	1.00	40.46	ATOM 3591	CD GLN 520	29.910	45.009	13.243	1.00	60.14	C2
ATOM 3556	OG1 THR 517	33.832	47.429	9.103	1.00	43.22	ATOM 3592	OE1 GLN 520	28.988	45.566	13.854	1.00	61.62	C2
ATOM 3557	HG1 THR 517	34.536	46.815	9.335	1.00	0.00	ATOM 3593	NE2 GLN 520	31.172	45.456	13.371	1.00	60.46	C2
ATOM 3558	CG2 THR 517	32.232	47.926	7.253	1.00	39.90	ATOM 3594	HE21 GLN 520	31.289	46.260	13.910	1.00	0.00	C2
ATOM 3559	C THR 517	31.343	45.012	7.551	1.00	38.30	ATOM 3595	HE22 GLN 520	31.895	44.966	12.932	1.00	0.00	C2
ATOM 3560	O THR 517	30.137	45.125	7.811	1.00	38.69	ATOM 3596	C GLN 520	27.141	43.577	9.621	1.00	46.28	C2
ATOM 3561	N ILE 518	31.790	44.344	6.466	1.00	37.54	ATOM 3597	O GLN 520	26.001	43.474	10.059	1.00	48.62	C2
ATOM 3562	H ILE 518	32.756	44.386	6.297	1.00	0.00	ATOM 3598	N GLN 521	27.362	44.145	8.442	1.00	46.99	C2

FIG. 5YY

ATOM 3599	H	GLN	521	28.272	44.257	8.092	1.00	0.00	C2	ATOM 3635	N	ALA	525	21.251	43.083	7.693	1.00	66.44	C2
ATOM 3600	CA	GLN	521	26.226	44.638	7.716	1.00	49.02	C2	ATOM 3636	H	ALA	525	22.196	43.283	7.516	1.00	0.00	C2
ATOM 3601	CB	GLN	521	26.632	45.553	6.566	1.00	50.06	C2	ATOM 3637	CA	ALA	525	20.371	42.789	6.574	1.00	68.58	C2
ATOM 3602	CG	GLN	521	25.456	46.226	5.790	1.00	50.87	C2	ATOM 3638	CB	ALA	525	21.117	43.044	5.288	1.00	67.42	C2
ATOM 3603	CD	GLN	521	24.616	47.278	6.534	1.00	51.82	C2	ATOM 3639	C	ALA	525	19.841	41.356	6.558	1.00	71.11	C2
ATOM 3604	OE1	GLN	521	24.864	47.694	7.671	1.00	52.47	C2	ATOM 3640	O	ALA	525	19.116	40.946	5.651	1.00	71.65	C2
ATOM 3605	NE2	GLN	521	23.577	47.776	5.888	1.00	50.36	C2	ATOM 3641	N	GLY	526	20.257	40.510	7.498	1.00	74.20	C2
ATOM 3606	HE21	GLN	521	23.392	47.455	4.987	1.00	0.00	C2	ATOM 3642	H	GLY	526	21.019	40.780	8.043	1.00	0.00	C2
ATOM 3607	HE22	GLN	521	23.044	48.424	6.390	1.00	0.00	C2	ATOM 3643	CA	GLY	526	19.728	39.157	7.653	1.00	76.30	C2
ATOM 3608	C	GLN	521	25.454	43.446	7.155	1.00	50.15	C2	ATOM 3644	C	GLY	526	20.430	38.085	6.842	1.00	78.19	C2
ATOM 3609	O	GLN	521	24.214	43.514	7.177	1.00	51.82	C2	ATOM 3645	O	GLY	526	20.174	36.910	7.094	1.00	79.05	C2
ATOM 3610	N	MET	522	26.057	42.348	6.668	1.00	49.18	C2	ATOM 3646	N	MET	527	21.388	38.433	5.970	1.00	80.23	C2
ATOM 3611	H	MET	522	27.038	42.291	6.688	1.00	0.00	C2	ATOM 3647	H	MET	527	21.759	39.337	6.075	1.00	0.00	C2
ATOM 3612	CA	MET	522	25.280	41.227	6.171	1.00	48.22	C2	ATOM 3648	CA	MET	527	22.055	37.489	5.063	1.00	81.73	C2
ATOM 3613	CB	MET	522	26.185	40.167	5.607	1.00	46.36	C2	ATOM 3649	CB	MET	527	22.771	38.256	3.928	1.00	81.72	C2
ATOM 3614	CG	MET	522	26.942	40.661	4.412	1.00	44.32	C2	ATOM 3650	CG	MET	527	22.385	39.719	3.720	1.00	83.52	C2
ATOM 3615	SD	MET	522	27.855	39.435	3.426	1.00	48.35	C2	ATOM 3651	SD	MET	527	23.364	40.523	2.436	1.00	87.64	C2
ATOM 3616	CE	MET	522	28.795	38.447	4.565	1.00	42.80	C2	ATOM 3652	CE	MET	527	22.600	42.117	2.409	1.00	84.47	C2
ATOM 3617	C	MET	522	24.453	40.642	7.316	1.00	50.14	C2	ATOM 3653	C	MET	527	23.078	36.584	5.780	1.00	82.64	C2
ATOM 3618	O	MET	522	23.380	40.124	7.038	1.00	50.60	C2	ATOM 3654	OT1	MET	527	22.974	35.357	5.624	1.00	83.38	C2
ATOM 3619	N	GLU	523	24.848	40.722	8.596	1.00	51.91	C2	ATOM 3655	OT2	MET	527	23.949	37.104	6.500	1.00	82.90	C2
ATOM 3620	H	GLU	523	25.766	41.031	8.769	1.00	0.00	C2	ATOM 3656	CB	MET	538	47.224	28.531	2.401	1.00	77.43	C3
ATOM 3621	CA	GLU	523	24.027	40.313	9.718	1.00	54.53	C2	ATOM 3657	CG	MET	538	47.397	30.041	2.427	1.00	77.15	C3
ATOM 3622	CB	GLU	523	24.654	40.486	11.081	1.00	54.60	C2	ATOM 3658	SD	MET	538	46.205	30.708	3.604	1.00	79.03	C3
ATOM 3623	CG	GLU	523	25.732	39.525	11.398	1.00	57.05	C2	ATOM 3659	CE	MET	538	44.850	31.067	2.515	1.00	77.20	C3
ATOM 3624	CD	GLU	523	25.386	38.150	10.888	1.00	61.72	C2	ATOM 3660	C	MET	538	48.549	27.839	0.386	1.00	75.32	C3
ATOM 3625	OE1	GLU	523	24.515	37.487	11.477	1.00	64.60	C2	ATOM 3661	O	MET	538	49.130	26.745	0.405	1.00	77.11	C3
ATOM 3626	OE2	GLU	523	25.979	37.773	9.872	1.00	63.19	C2	ATOM 3662	HT1	MET	538	47.563	26.068	1.449	1.00	0.00	C3
ATOM 3627	C	GLU	523	22.773	41.116	9.836	1.00	58.29	C2	ATOM 3663	HT2	MET	538	46.638	26.204	0.075	1.00	0.00	C3
ATOM 3628	O	GLU	523	21.688	40.538	9.850	1.00	59.32	C2	ATOM 3664	N	MET	538	46.724	26.552	1.050	1.00	77.52	C3
ATOM 3629	N	ALA	524	22.920	42.432	9.992	1.00	61.41	C2	ATOM 3665	HT3	MET	538	45.873	26.401	1.617	1.00	0.00	C3
ATOM 3630	H	ALA	524	23.834	42.798	10.024	1.00	0.00	C2	ATOM 3666	CA	MET	538	47.153	27.940	0.995	1.00	76.57	C3
ATOM 3631	CA	ALA	524	21.815	43.360	10.076	1.00	63.58	C2	ATOM 3667	N	PRO	539	49.089	28.870	-0.224	1.00	72.65	C3
ATOM 3632	CB	ALA	524	22.382	44.768	9.992	1.00	64.11	C2	ATOM 3668	CD	PRO	539	48.346	29.821	-1.046	1.00	72.26	C3
ATOM 3633	C	ALA	524	20.818	43.109	8.946	1.00	64.79	C2	ATOM 3669	CA	PRO	539	50.526	29.020	-0.349	1.00	70.34	C3
ATOM 3634	O	ALA	524	19.655	42.824	9.206	1.00	65.69	C2	ATOM 3670	CB	PRO	539	50.677	30.365	-1.006	1.00	71.39	C3

FIG. 5ZZ

ATOM 3671	CG PRO	539	49.437	30.503	-1.837	1.00	71.52	C3	ATOM 3707	H ALA	544	63.929	32.951	2.650	1.00	0.00	C3
ATOM 3672	C PRO	539	51.250	28.931	0.991	1.00	67.83	C3	ATOM 3708	CA ALA	544	63.035	34.836	2.345	1.00	37.31	C3
ATOM 3673	O PRO	539	50.666	29.294	2.029	1.00	68.05	C3	ATOM 3709	CB ALA	544	64.340	35.450	2.808	1.00	35.74	C3
ATOM 3674	N ALA	540	52.484	28.417	0.961	1.00	64.48	C3	ATOM 3710	C ALA	544	62.723	35.372	0.947	1.00	37.06	C3
ATOM 3675	H ALA	540	52.858	28.098	0.111	1.00	0.00	C3	ATOM 3711	O ALA	544	61.829	36.220	0.820	1.00	38.23	C3
ATOM 3676	CA ALA	540	53.389	28.498	2.112	1.00	61.83	C3	ATOM 3712	N PHE	545	63.357	34.881	-0.130	1.00	35.72	C3
ATOM 3677	CB ALA	540	54.004	27.200	2.619	1.00	63.57	C3	ATOM 3713	H PHE	545	64.131	34.298	-0.010	1.00	0.00	C3
ATOM 3678	C ALA	540	54.559	29.212	1.496	1.00	58.74	C3	ATOM 3714	CA PHE	545	62.992	35.268	-1.484	1.00	33.66	C3
ATOM 3679	O ALA	540	54.835	29.036	0.301	1.00	58.30	C3	ATOM 3715	CB PHE	545	63.738	34.534	-2.593	1.00	29.71	C3
ATOM 3680	N PHE	541	55.256	30.008	2.292	1.00	55.25	C3	ATOM 3716	CG PHE	545	63.140	34.742	-3.990	1.00	29.62	C3
ATOM 3681	H PHE	541	55.093	30.068	3.257	1.00	0.00	C3	ATOM 3717	CD1 PHE	545	62.317	33.788	-4.557	1.00	29.80	C3
ATOM 3682	CA PHE	541	56.299	30.814	1.702	1.00	51.38	C3	ATOM 3718	CD2 PHE	545	63.371	35.915	-4.689	1.00	31.90	C3
ATOM 3683	CB PHE	541	55.964	32.306	1.942	1.00	48.80	C3	ATOM 3719	CE1 PHE	545	61.723	33.984	-5.795	1.00	28.61	C3
ATOM 3684	CG PHE	541	54.789	32.703	1.058	1.00	45.77	C3	ATOM 3720	CE2 PHE	545	62.777	36.113	-5.928	1.00	31.00	C3
ATOM 3685	CD1 PHE	541	54.992	32.939	-0.279	1.00	44.20	C3	ATOM 3721	CZ PHE	545	61.955	35.150	-6.480	1.00	31.01	C3
ATOM 3686	CD2 PHE	541	53.507	32.747	1.582	1.00	44.76	C3	ATOM 3722	C PHE	545	61.543	34.900	-1.667	1.00	34.81	C3
ATOM 3687	CE1 PHE	541	53.901	33.207	-1.074	1.00	43.98	C3	ATOM 3723	O PHE	545	60.901	35.660	-2.389	1.00	38.88	C3
ATOM 3688	CE2 PHE	541	52.428	33.018	0.769	1.00	42.86	C3	ATOM 3724	N GLN	546	60.912	33.847	-1.135	1.00	34.77	C3
ATOM 3689	CZ PHE	541	52.625	33.247	-0.563	1.00	42.52	C3	ATOM 3725	H GLN	546	61.396	33.223	-0.558	1.00	0.00	C3
ATOM 3690	C PHE	541	57.586	30.364	2.333	1.00	49.80	C3	ATOM 3726	CA GLN	546	59.490	33.637	-1.433	1.00	33.72	C3
ATOM 3691	O PHE	541	58.002	30.807	3.395	1.00	49.55	C3	ATOM 3727	CB GLN	546	59.145	32.232	-1.140	1.00	34.85	C3
ATOM 3692	N ALA	542	58.172	29.442	1.562	1.00	48.21	C3	ATOM 3728	CG GLN	546	59.582	31.585	-2.444	1.00	42.45	C3
ATOM 3693	H ALA	542	57.825	29.298	0.656	1.00	0.00	C3	ATOM 3729	CD GLN	546	59.374	30.085	-2.473	1.00	46.05	C3
ATOM 3694	CA ALA	542	59.326	28.711	1.968	1.00	45.37	C3	ATOM 3730	OE1 GLN	546	59.287	29.472	-1.399	1.00	48.90	C3
ATOM 3695	CB ALA	542	59.700	27.749	0.898	1.00	45.21	C3	ATOM 3731	NE2 GLN	546	59.339	29.442	-3.644	1.00	47.20	C3
ATOM 3696	C ALA	542	60.510	29.567	2.266	1.00	44.87	C3	ATOM 3732	HE21 GLN	546	59.476	29.948	-4.472	1.00	0.00	C3
ATOM 3697	O ALA	542	61.001	29.504	3.374	1.00	46.49	C3	ATOM 3733	HE22 GLN	546	59.154	28.481	-3.609	1.00	0.00	C3
ATOM 3698	N SER	543	61.013	30.408	1.395	1.00	42.63	C3	ATOM 3734	C GLN	546	58.504	34.541	-0.729	1.00	31.62	C3
ATOM 3699	H SER	543	60.477	30.685	0.630	1.00	0.00	C3	ATOM 3735	O GLN	546	57.429	34.850	-1.233	1.00	29.88	C3
ATOM 3700	CA SER	543	62.253	31.108	1.708	1.00	40.31	C3	ATOM 3736	N ARG	547	58.907	34.929	0.465	1.00	31.09	C3
ATOM 3701	CB SER	543	63.170	30.861	0.587	1.00	37.74	C3	ATOM 3737	H ARG	547	59.750	34.566	0.811	1.00	0.00	C3
ATOM 3702	OG SER	543	62.391	31.181	-0.554	1.00	35.74	C3	ATOM 3738	CA ARG	547	58.160	35.830	1.282	1.00	31.43	C3
ATOM 3703	HG SER	543	61.824	30.423	-0.751	1.00	0.00	C3	ATOM 3739	CB ARG	547	58.813	35.874	2.601	1.00	31.74	C3
ATOM 3704	C SER	543	62.087	32.613	1.896	1.00	40.88	C3	ATOM 3740	CG ARG	547	57.906	35.224	3.623	1.00	37.02	C3
ATOM 3705	O SER	543	61.016	33.115	1.536	1.00	42.63	C3	ATOM 3741	CD ARG	547	58.344	33.858	4.076	1.00	40.56	C3
ATOM 3706	N ALA	544	63.120	33.383	2.310	1.00	38.84	C3	ATOM 3742	NE ARG	547	59.743	34.058	4.345	1.00	47.90	C3

FIG. 5AAA

ATOM 3743 HE ARG 547	60.389	33.924	3.620	1.00	0.00	C3	ATOM 3779 C GLY 550	54.410	38.098	-2.075	1.00	26.94	C3
ATOM 3744 CZ ARG 547	60.190	34.394	5.543	1.00	49.48	C3	ATOM 3780 O GLY 550	53.339	38.380	-2.608	1.00	26.59	C3
ATOM 3745 NHI ARG 547	59.361	34.522	6.593	1.00	51.97	C3	ATOM 3781 N GLY 551	55.073	38.917	-1.234	1.00	27.78	C3
ATOM 3746 HH11 ARG 547	58.380	34.356	6.488	1.00	0.00	C3	ATOM 3782 H GLY 551	55.958	38.642	-0.925	1.00	0.00	C3
ATOM 3747 HH12 ARG 547	59.731	34.763	7.491	1.00	0.00	C3	ATOM 3783 CA GLY 551	54.540	40.212	-0.779	1.00	26.51	C3
ATOM 3748 NH2 ARG 547	61.464	34.775	5.616	1.00	48.55	C3	ATOM 3784 C GLY 551	54.302	41.113	-1.994	1.00	26.82	C3
ATOM 3749 HH21 ARG 547	62.025	34.803	4.788	1.00	0.00	C3	ATOM 3785 O GLY 551	53.313	41.852	-2.065	1.00	27.82	C3
ATOM 3750 HH22 ARG 547	61.854	35.034	6.501	1.00	0.00	C3	ATOM 3786 N VAL 552	55.154	41.013	-3.012	1.00	25.81	C3
ATOM 3751 C ARG 547	58.167	37.181	0.590	1.00	32.26	C3	ATOM 3787 H VAL 552	55.916	40.396	-2.954	1.00	0.00	C3
ATOM 3752 O ARG 547	57.084	37.694	0.317	1.00	34.25	C3	ATOM 3788 CA VAL 552	54.952	41.843	-4.176	1.00	28.39	C3
ATOM 3753 N ARG 548	59.348	37.717	0.205	1.00	31.44	C3	ATOM 3789 CB VAL 552	56.178	41.743	-5.190	1.00	26.20	C3
ATOM 3754 H ARG 548	60.148	37.203	0.444	1.00	0.00	C3	ATOM 3790 CG1 VAL 552	55.917	42.391	-6.541	1.00	26.53	C3
ATOM 3755 CA ARG 548	59.529	38.980	-0.555	1.00	30.01	C3	ATOM 3791 CG2 VAL 552	57.327	42.546	-4.594	1.00	26.44	C3
ATOM 3756 CB ARG 548	60.995	39.213	-0.949	1.00	25.42	C3	ATOM 3792 C VAL 552	53.650	41.406	-4.820	1.00	29.05	C3
ATOM 3757 CG ARG 548	61.820	39.361	0.294	1.00	26.11	C3	ATOM 3793 O VAL 552	52.744	42.251	-4.888	1.00	31.68	C3
ATOM 3758 CD ARG 548	63.280	39.158	-0.054	1.00	29.34	C3	ATOM 3794 N LEU 553	53.455	40.120	-5.176	1.00	27.20	C3
ATOM 3759 NE ARG 548	64.044	39.162	1.189	1.00	32.30	C3	ATOM 3795 H LEU 553	54.122	39.447	-4.908	1.00	0.00	C3
ATOM 3760 HE ARG 548	63.572	38.883	1.995	1.00	0.00	C3	ATOM 3796 CA LEU 553	52.266	39.705	-5.915	1.00	23.80	C3
ATOM 3761 CZ ARG 548	65.344	39.518	1.325	1.00	32.66	C3	ATOM 3797 CB LEU 553	52.357	38.262	-6.363	1.00	24.86	C3
ATOM 3762 NHI ARG 548	66.159	39.923	0.335	1.00	34.98	C3	ATOM 3798 CG LEU 553	53.432	37.955	-7.357	1.00	23.06	C3
ATOM 3763 HH11 ARG 548	67.107	40.170	0.533	1.00	0.00	C3	ATOM 3799 CD1 LEU 553	54.073	36.623	-7.092	1.00	24.31	C3
ATOM 3764 HH12 ARG 548	65.812	39.981	-0.600	1.00	0.00	C3	ATOM 3800 CD2 LEU 553	52.794	38.061	-8.703	1.00	21.87	C3
ATOM 3765 NH2 ARG 548	65.837	39.518	2.549	1.00	32.03	C3	ATOM 3801 C LEU 553	51.012	39.825	-5.114	1.00	23.72	C3
ATOM 3766 HH21 ARG 548	66.788	39.783	2.708	1.00	0.00	C3	ATOM 3802 O LEU 553	49.982	40.138	-5.712	1.00	24.63	C3
ATOM 3767 HH22 ARG 548	65.250	39.275	3.321	1.00	0.00	C3	ATOM 3803 N VAL 554	50.962	39.580	-3.803	1.00	24.37	C3
ATOM 3768 C ARG 548	58.713	38.997	-1.832	1.00	29.81	C3	ATOM 3804 H VAL 554	51.774	39.350	-3.295	1.00	0.00	C3
ATOM 3769 O ARG 548	57.778	39.790	-1.968	1.00	33.03	C3	ATOM 3805 CA VAL 554	49.660	39.691	-3.180	1.00	26.36	C3
ATOM 3770 N ALA 549	58.979	38.102	-2.761	1.00	27.87	C3	ATOM 3806 CB VAL 554	49.472	38.751	-1.802	1.00	26.55	C3
ATOM 3771 H ALA 549	59.684	37.436	-2.601	1.00	0.00	C3	ATOM 3807 CG1 VAL 554	50.696	37.933	-1.418	1.00	23.95	C3
ATOM 3772 CA ALA 549	58.227	38.045	-3.984	1.00	27.18	C3	ATOM 3808 CG2 VAL 554	48.953	39.614	-0.682	1.00	25.58	C3
ATOM 3773 CB ALA 549	58.797	36.934	4.857	1.00	28.72	C3	ATOM 3809 C VAL 554	49.322	41.175	-2.960	1.00	27.53	C3
ATOM 3774 C ALA 549	56.748	37.810	-3.770	1.00	25.91	C3	ATOM 3810 O VAL 554	48.142	41.502	-3.192	1.00	27.44	C3
ATOM 3775 O ALA 549	55.896	38.337	4.468	1.00	26.03	C3	ATOM 3811 N ALA 555	50.277	42.106	-2.716	1.00	28.04	C3
ATOM 3776 N GLY 550	56.421	37.074	-2.748	1.00	26.53	C3	ATOM 3812 H ALA 555	51.221	41.831	-2.658	1.00	0.00	C3
ATOM 3777 H GLY 550	57.103	36.657	-2.185	1.00	0.00	C3	ATOM 3813 CA ALA 555	49.956	43.539	-2.509	1.00	28.57	C3
ATOM 3778 CA GLY 550	55.055	36.805	-2.457	1.00	26.08	C3	ATOM 3814 CB ALA 555	51.161	44.427	-2.217	1.00	28.07	C3

FIG. 5BBB

ATOM 3815	C	ALA	555	49.402	44.055	-3.803	1.00	28.12	C3	ATOM 3851	CG	GLN	559	46.707	48.543	-5.875	1.00	42.07	C3
ATOM 3816	O	ALA	555	48.425	44.803	-3.847	1.00	30.12	C3	ATOM 3852	CD	GLN	559	46.530	49.618	-4.793	1.00	41.53	C3
ATOM 3817	N	SER	556	49.985	43.521	-4.839	1.00	26.44	C3	ATOM 3853	OE1	GLN	559	45.961	50.687	-5.057	1.00	41.25	C3
ATOM 3818	H	SER	556	50.781	42.956	-4.710	1.00	0.00	C3	ATOM 3854	NE2	GLN	559	46.951	49.416	-3.561	1.00	37.96	C3
ATOM 3819	CA	SER	556	49.548	43.810	-6.152	1.00	30.09	C3	ATOM 3855	HE21	GLN	559	47.271	48.528	-3.311	1.00	0.00	C3
ATOM 3820	CB	SER	556	50.684	43.277	-6.965	1.00	31.42	C3	ATOM 3856	HE22	GLN	559	47.001	50.190	-2.967	1.00	0.00	C3
ATOM 3821	OG	SER	556	50.442	43.338	-8.344	1.00	37.88	C3	ATOM 3857	C	GLN	559	44.142	46.635	-5.976	1.00	35.22	C3
ATOM 3822	HG	SER	556	49.966	44.144	-8.576	1.00	0.00	C3	ATOM 3858	O	GLN	559	43.165	47.404	-5.839	1.00	34.99	C3
ATOM 3823	C	SER	556	48.143	43.243	-6.454	1.00	32.78	C3	ATOM 3859	N	SER	560	44.260	45.817	-7.025	1.00	33.46	C3
ATOM 3824	O	SER	556	47.287	43.961	-7.003	1.00	34.56	C3	ATOM 3860	H	SER	560	45.083	45.292	-7.154	1.00	0.00	C3
ATOM 3825	N	HIS	557	47.750	42.019	-6.088	1.00	32.78	C3	ATOM 3861	CA	SER	560	43.222	45.683	-8.049	1.00	32.88	C3
ATOM 3826	H	HIS	557	48.350	41.453	-5.560	1.00	0.00	C3	ATOM 3862	CB	SER	560	43.693	44.776	-9.088	1.00	34.05	C3
ATOM 3827	CA	HIS	557	46.396	41.605	-6.401	1.00	33.64	C3	ATOM 3863	OG	SER	560	45.021	45.174	-9.281	1.00	42.40	C3
ATOM 3828	CB	HIS	557	46.203	40.142	-6.242	1.00	37.88	C3	ATOM 3864	HG	SER	560	45.042	45.996	-9.783	1.00	0.00	C3
ATOM 3829	CG	HIS	557	46.986	39.518	-7.348	1.00	42.44	C3	ATOM 3865	C	SER	560	41.885	45.133	-7.559	1.00	32.01	C3
ATOM 3830	CD2	HIS	557	46.694	39.665	-8.675	1.00	43.63	C3	ATOM 3866	O	SER	560	40.791	45.582	-7.920	1.00	32.23	C3
ATOM 3831	ND1	HIS	557	48.108	38.837	-7.209	1.00	45.23	C3	ATOM 3867	N	PHE	561	41.969	44.123	-6.710	1.00	29.50	C3
ATOM 3832	HD1	HIS	557	48.641	38.764	-6.385	1.00	0.00	C3	ATOM 3868	H	PHE	561	42.850	43.767	-6.464	1.00	0.00	C3
ATOM 3833	CE1	HIS	557	48.524	38.569	-8.414	1.00	46.56	C3	ATOM 3869	CA	PHE	561	40.803	43.529	-6.118	1.00	28.17	C3
ATOM 3834	NE2	HIS	557	47.676	39.066	-9.283	1.00	45.62	C3	ATOM 3870	CB	PHE	561	41.237	42.541	-5.040	1.00	26.27	C3
ATOM 3835	HE2	HIS	557	47.793	39.018	-10.257	1.00	0.00	C3	ATOM 3871	CG	PHE	561	40.069	41.966	-4.268	1.00	25.68	C3
ATOM 3836	C	HIS	557	45.383	42.249	-5.520	1.00	32.94	C3	ATOM 3872	CD1	PHE	561	39.282	40.999	-4.846	1.00	25.44	C3
ATOM 3837	O	HIS	557	44.256	42.444	-5.934	1.00	33.08	C3	ATOM 3873	CD2	PHE	561	39.761	42.482	-3.051	1.00	25.45	C3
ATOM 3838	N	LEU	558	45.744	42.534	-4.280	1.00	33.05	C3	ATOM 3874	CE1	PHE	561	38.166	40.551	-4.215	1.00	21.49	C3
ATOM 3839	H	LEU	558	46.657	42.356	-3.986	1.00	0.00	C3	ATOM 3875	CE2	PHE	561	38.635	42.027	-2.421	1.00	26.89	C3
ATOM 3840	CA	LEU	558	44.817	43.125	-3.348	1.00	31.91	C3	ATOM 3876	CZ	PHE	561	37.853	41.074	-3.008	1.00	24.29	C3
ATOM 3841	CB	LEU	558	45.420	43.107	-1.965	1.00	29.25	C3	ATOM 3877	C	PHE	561	39.987	44.645	-5.505	1.00	28.81	C3
ATOM 3842	CG	LEU	558	44.605	43.615	-0.818	1.00	26.02	C3	ATOM 3878	O	PHE	561	38.789	44.697	-5.731	1.00	29.31	C3
ATOM 3843	CD1	LEU	558	43.279	42.883	-0.742	1.00	25.00	C3	ATOM 3879	N	LEU	562	40.672	45.565	-4.797	1.00	28.39	C3
ATOM 3844	CD2	LEU	558	45.496	43.571	0.408	1.00	22.86	C3	ATOM 3880	H	LEU	562	41.643	45.462	-4.707	1.00	0.00	C3
ATOM 3845	C	LEU	558	44.527	44.521	-3.783	1.00	32.47	C3	ATOM 3881	CA	LEU	562	40.033	46.617	-4.057	1.00	26.51	C3
ATOM 3846	O	LEU	558	43.402	44.944	-3.596	1.00	33.97	C3	ATOM 3882	CB	LEU	562	40.964	47.203	-3.074	1.00	23.80	C3
ATOM 3847	N	GLN	559	45.482	45.231	-4.370	1.00	34.36	C3	ATOM 3883	CG	LEU	562	41.047	46.411	-1.816	1.00	24.85	C3
ATOM 3848	H	GLN	559	46.386	44.855	-4.406	1.00	0.00	C3	ATOM 3884	CD1	LEU	562	42.207	46.868	-1.049	1.00	24.07	C3
ATOM 3849	CA	GLN	559	45.255	46.569	-4.912	1.00	36.75	C3	ATOM 3885	CD2	LEU	562	39.794	46.551	-1.008	1.00	25.13	C3
ATOM 3850	CB	GLN	559	46.598	47.067	-5.470	1.00	39.63	C3	ATOM 3886	C	LEU	562	39.586	47.669	-4.988	1.00	29.27	C3

FIG. 5CCC

ATOM 3887	O	LEU	562	38.580	48.304	-4.681	1.00	29.83	36.599	54.787	-7.735	1.00	75.29	C3
ATOM 3888	N	GLU	563	40.239	47.871	-6.115	1.00	30.88	36.538	55.838	-8.652	1.00	77.42	C3
ATOM 3889	H	GLU	563	41.052	47.368	-6.325	1.00	0.00	36.905	55.565	-9.494	1.00	0.00	C3
ATOM 3890	CA	GLU	563	39.738	48.908	-6.966	1.00	36.88	34.524	50.696	-6.217	1.00	48.48	C3
ATOM 3891	CB	GLU	563	40.660	49.142	-8.137	1.00	40.80	33.545	51.376	-5.950	1.00	46.35	C3
ATOM 3892	CG	GLU	563	41.999	49.628	-7.682	1.00	48.55	34.679	50.115	-7.417	1.00	49.14	C3
ATOM 3893	CD	GLU	563	43.148	49.277	-8.619	1.00	55.42	35.512	49.625	-7.572	1.00	0.00	C3
ATOM 3894	OE1	GLU	563	44.301	49.283	-8.135	1.00	57.39	33.670	50.165	-8.490	1.00	52.09	C3
ATOM 3895	OE2	GLU	563	42.886	48.986	-9.808	1.00	56.44	34.210	49.574	-9.788	1.00	48.37	C3
ATOM 3896	C	GLU	563	38.375	48.469	-7.466	1.00	39.02	32.315	49.449	-8.238	1.00	55.31	C3
ATOM 3897	O	GLU	563	37.388	49.170	-7.270	1.00	39.09	31.226	50.008	-8.501	1.00	56.87	C3
ATOM 3898	N	VAL	564	38.289	47.255	-8.030	1.00	42.30	32.247	48.211	-7.736	1.00	57.66	C3
ATOM 3899	H	VAL	564	39.107	46.714	-8.074	1.00	0.00	33.083	47.729	-7.564	1.00	0.00	C3
ATOM 3900	CA	VAL	564	37.052	46.683	-8.558	1.00	41.84	30.980	47.573	-7.490	1.00	59.61	C3
ATOM 3901	CB	VAL	564	37.333	45.255	-9.041	1.00	42.27	31.119	46.031	-7.339	1.00	58.96	C3
ATOM 3902	CG1	VAL	564	36.055	44.538	-9.435	1.00	41.17	31.239	45.508	-5.911	1.00	60.27	C3
ATOM 3903	CG2	VAL	564	38.283	45.348	-10.241	1.00	42.11	29.851	45.471	-7.922	1.00	60.44	C3
ATOM 3904	C	VAL	564	36.030	46.709	-7.442	1.00	41.68	30.393	48.177	-6.245	1.00	62.66	C3
ATOM 3905	O	VAL	564	34.892	47.015	-7.697	1.00	42.34	29.174	48.154	-6.180	1.00	64.78	C3
ATOM 3906	N	SER	565	36.419	46.501	-6.206	1.00	42.75	31.075	48.737	-5.248	1.00	66.15	C3
ATOM 3907	H	SER	565	37.333	46.173	-6.063	1.00	0.00	32.058	48.719	-5.243	1.00	0.00	C3
ATOM 3908	CA	SER	565	35.562	46.602	-5.064	1.00	44.85	30.359	49.334	-4.123	1.00	69.85	C3
ATOM 3909	CB	SER	565	36.344	46.013	-3.894	1.00	46.54	31.285	49.858	-3.023	1.00	69.91	C3
ATOM 3910	OG	SER	565	35.590	45.714	-2.731	1.00	51.75	32.007	48.887	-2.095	1.00	70.17	C3
ATOM 3911	HG	SER	565	35.060	46.481	-2.491	1.00	0.00	32.847	49.687	-1.140	1.00	70.19	C3
ATOM 3912	C	SER	565	35.167	48.063	-4.871	1.00	45.70	31.039	48.054	-1.286	1.00	70.56	C3
ATOM 3913	O	SER	565	34.038	48.287	-4.446	1.00	46.87	29.567	50.509	-4.667	1.00	72.69	C3
ATOM 3914	N	TYR	566	35.965	49.093	-5.146	1.00	47.59	28.365	50.553	-4.425	1.00	73.80	C3
ATOM 3915	H	TYR	566	36.893	48.908	-5.386	1.00	0.00	30.180	51.391	-5.479	1.00	75.95	C3
ATOM 3916	CA	TYR	566	35.518	50.474	-5.086	1.00	49.68	31.153	51.299	-5.580	1.00	0.00	C3
ATOM 3917	CB	TYR	566	36.765	51.362	-5.164	1.00	56.17	29.510	52.498	-6.173	1.00	78.78	C3
ATOM 3918	CG	TYR	566	36.715	52.622	-6.007	1.00	64.64	30.399	53.068	-7.308	1.00	80.07	C3
ATOM 3919	CD1	TYR	566	37.264	52.538	-7.278	1.00	69.53	29.658	54.222	-7.997	1.00	84.16	C3
ATOM 3920	CE1	TYR	566	37.212	53.613	-8.151	1.00	73.71	29.976	54.744	-9.417	1.00	85.66	C3
ATOM 3921	CD2	TYR	566	36.109	53.797	-5.569	1.00	67.98	28.892	55.690	-9.737	1.00	85.67	C3
ATOM 3922	CE2	TYR	566	36.048	54.888	-6.441	1.00	72.92	27.971	55.354	-9.727	1.00	0.00	C3

FIG. 5DDD

ATOM 3959	CZ ARG 570	29.051	56.991	-10.026	1.00	85.06	C3	ATOM 3995	OT1 ALA 573	22.610	52.413	-3.099	1.00	88.33	C3
ATOM 3960	NH1 ARG 570	30.240	57.590	-10.082	1.00	84.43	C3	ATOM 3996	OT2 ALA 573	23.022	52.309	-5.248	1.00	88.34	C3
ATOM 3961	HH11 ARG 570	31.069	57.056	-9.908	1.00	0.00	C3	ATOM 3997	OH2 H2O 603	26.735	24.280	5.161	1.00	27.42	W
ATOM 3962	HH12 ARG 570	30.295	58.561	-10.314	1.00	0.00	C3	ATOM 3998	H1 H2O 603	27.332	24.335	4.407	1.00	0.00	W
ATOM 3963	NH2 ARG 570	27.958	57.736	-10.154	1.00	84.57	C3	ATOM 3999	H2 H2O 603	26.288	23.435	4.992	1.00	0.00	W
ATOM 3964	HH21 ARG 570	27.059	57.316	-10.030	1.00	0.00	C3	ATOM 4000	OH2 H2O 605	47.880	37.960	12.073	1.00	56.30	W
ATOM 3965	HH22 ARG 570	28.042	58.708	-10.375	1.00	0.00	C3	ATOM 4001	H1 H2O 605	47.789	37.874	13.031	1.00	0.00	W
ATOM 3966	C ARG 570	28.201	52.009	-6.812	1.00	79.92	C3	ATOM 4002	H2 H2O 605	46.980	37.858	11.753	1.00	0.00	W
ATOM 3967	O ARG 570	27.107	52.565	-6.709	1.00	79.61	C3	ATOM 4003	OH2 H2O 607	40.001	49.224	7.214	1.00	40.04	W
ATOM 3968	N HIS 571	28.362	50.900	-7.511	1.00	81.35	C3	ATOM 4004	H1 H2O 607	40.471	48.761	7.909	1.00	0.00	W
ATOM 3969	H HIS 571	29.214	50.417	-7.440	1.00	0.00	C3	ATOM 4005	H2 H2O 607	40.123	48.642	6.457	1.00	0.00	W
ATOM 3970	CA HIS 571	27.247	50.306	-8.197	1.00	82.75	C3	ATOM 4006	OH2 H2O 610	59.883	42.530	-9.698	1.00	38.90	W
ATOM 3971	CB HIS 571	27.882	49.274	-9.167	1.00	83.42	C3	ATOM 4007	H1 H2O 610	60.512	41.833	-9.477	1.00	0.00	W
ATOM 3972	CG HIS 571	28.633	50.029	-10.280	1.00	85.08	C3	ATOM 4008	H2 H2O 610	59.189	42.046	-10.160	1.00	0.00	W
ATOM 3973	CD2 HIS 571	28.921	49.529	-11.532	1.00	85.81	C3	ATOM 4009	OH2 H2O 611	57.178	35.940	-14.220	1.00	34.63	W
ATOM 3974	ND1 HIS 571	29.074	51.303	-10.268	1.00	86.25	C3	ATOM 4010	H1 H2O 611	57.174	36.545	-14.974	1.00	0.00	W
ATOM 3975	HD1 HIS 571	29.080	51.900	-9.489	1.00	0.00	C3	ATOM 4011	H2 H2O 611	57.989	36.211	-13.757	1.00	0.00	W
ATOM 3976	CE1 HIS 571	29.595	51.595	-11.439	1.00	86.01	C3	ATOM 4012	OH2 H2O 612	25.793	27.337	19.130	1.00	29.21	W
ATOM 3977	NE2 HIS 571	29.494	50.518	-12.187	1.00	86.28	C3	ATOM 4013	H1 H2O 612	26.709	27.661	19.145	1.00	0.00	W
ATOM 3978	HE2 HIS 571	29.801	50.468	-13.119	1.00	0.00	C3	ATOM 4014	H2 H2O 612	25.762	26.792	19.929	1.00	0.00	W
ATOM 3979	C HIS 571	26.225	49.759	-7.195	1.00	83.31	C3	ATOM 4015	OH2 H2O 615	29.766	34.284	9.444	1.00	45.03	W
ATOM 3980	O HIS 571	25.075	50.194	-7.301	1.00	84.06	C3	ATOM 4016	H1 H2O 615	30.017	34.618	10.308	1.00	0.00	W
ATOM 3981	N LEU 572	26.540	48.963	-6.158	1.00	83.11	C3	ATOM 4017	H2 H2O 615	29.113	33.592	9.660	1.00	0.00	W
ATOM 3982	H LEU 572	27.474	48.824	-5.915	1.00	0.00	C3	ATOM 4018	OH2 H2O 617	37.316	40.012	10.872	1.00	35.21	W
ATOM 3983	CA LEU 572	25.527	48.457	-5.241	1.00	83.71	C3	ATOM 4019	H1 H2O 617	36.600	40.017	11.519	1.00	0.00	W
ATOM 3984	CB LEU 572	26.085	47.267	-4.454	1.00	83.57	C3	ATOM 4020	H2 H2O 617	37.944	39.376	11.259	1.00	0.00	W
ATOM 3985	CG LEU 572	25.439	45.884	-4.721	1.00	83.79	C3	ATOM 4021	OH2 H2O 619	40.370	52.041	-7.387	1.00	29.62	W
ATOM 3986	CD1 LEU 572	25.783	45.386	-6.127	1.00	84.16	C3	ATOM 4022	H1 H2O 619	40.672	52.724	-6.779	1.00	0.00	W
ATOM 3987	CD2 LEU 572	25.958	44.866	-3.714	1.00	84.08	C3	ATOM 4023	H2 H2O 619	39.505	51.810	-7.052	1.00	0.00	W
ATOM 3988	C LEU 572	24.997	49.511	-4.261	1.00	84.78	C3	ATOM 4024	OH2 H2O 621	27.903	32.440	10.664	1.00	39.99	W
ATOM 3989	O LEU 572	24.265	49.192	-3.295	1.00	84.85	C3	ATOM 4025	H1 H2O 621	27.553	33.207	11.141	1.00	0.00	W
ATOM 3990	N ALA 573	25.349	50.796	-4.483	1.00	85.56	C3	ATOM 4026	H2 H2O 621	27.929	31.808	11.398	1.00	0.00	W
ATOM 3991	H ALA 573	26.020	50.980	-5.174	1.00	0.00	C3	ATOM 4027	OH2 H2O 622	25.057	31.972	13.675	1.00	32.70	W
ATOM 3992	CA ALA 573	24.822	51.925	-3.721	1.00	85.90	C3	ATOM 4028	H1 H2O 622	24.393	32.417	14.215	1.00	0.00	W
ATOM 3993	CB ALA 573	25.600	53.207	-3.970	1.00	85.79	C3	ATOM 4029	H2 H2O 622	24.469	31.428	13.112	1.00	0.00	W
ATOM 3994	C ALA 573	23.373	52.245	-4.057	1.00	87.21	C3	ATOM 4030	OH2 H2O 623	20.791	28.583	14.218	1.00	50.17	W

FIG. 5EEE

ATOM	4031	H1	H2O	623	20.499	28.803	13.325	1.00	0.00	W	ATOM	4067	H1	H2O	653	49.442	55.351	1.474	1.00	0.00	W
ATOM	4032	H2	H2O	623	19.939	28.549	14.688	1.00	0.00	W	ATOM	4068	H2	H2O	653	49.323	56.829	1.630	1.00	0.00	W
ATOM	4033	OH2	H2O	625	22.680	78.881	2.761	1.00	40.48	W	ATOM	4069	OH2	H2O	654	68.215	42.294	-2.563	1.00	40.77	W
ATOM	4034	H1	H2O	625	21.938	78.856	3.375	1.00	0.00	W	ATOM	4070	H1	H2O	654	68.347	41.745	-1.777	1.00	0.00	W
ATOM	4035	H2	H2O	625	22.266	79.246	1.970	1.00	0.00	W	ATOM	4071	H2	H2O	654	68.189	43.181	-2.190	1.00	0.00	W
ATOM	4036	OH2	H2O	626	39.689	36.486	9.730	1.00	23.36	W	ATOM	4072	OH2	H2O	655	66.374	40.425	-2.489	1.00	42.31	W
ATOM	4037	H1	H2O	626	39.090	35.724	9.672	1.00	0.00	W	ATOM	4073	H1	H2O	655	66.936	41.162	-2.766	1.00	0.00	W
ATOM	4038	H2	H2O	626	39.627	36.872	8.853	1.00	0.00	W	ATOM	4074	H2	H2O	655	66.452	39.841	-3.252	1.00	0.00	W
ATOM	4039	OH2	H2O	627	42.035	78.320	5.697	1.00	46.19	W	ATOM	4075	OH2	H2O	656	66.927	41.428	-5.011	1.00	44.08	W
ATOM	4040	H1	H2O	627	42.416	77.450	5.832	1.00	0.00	W	ATOM	4076	H1	H2O	656	66.207	42.071	-4.989	1.00	0.00	W
ATOM	4041	H2	H2O	627	41.243	78.146	5.181	1.00	0.00	W	ATOM	4077	H2	H2O	656	67.542	41.824	-4.374	1.00	0.00	W
ATOM	4042	OH2	H2O	631	47.227	31.440	6.299	1.00	34.17	W	ATOM	4078	OH2	H2O	657	40.371	57.111	5.730	1.00	66.56	W
ATOM	4043	H1	H2O	631	47.533	32.209	5.809	1.00	0.00	W	ATOM	4079	H1	H2O	657	39.958	56.259	5.613	1.00	0.00	W
ATOM	4044	H2	H2O	631	47.442	30.713	5.714	1.00	0.00	W	ATOM	4080	H2	H2O	657	40.021	57.651	5.014	1.00	0.00	W
ATOM	4045	OH2	H2O	636	24.043	65.423	-0.336	1.00	73.38	W	ATOM	4081	OH2	H2O	658	48.780	47.580	-3.122	1.00	52.09	W
ATOM	4046	H1	H2O	636	24.179	65.781	-1.228	1.00	0.00	W	ATOM	4082	H1	H2O	658	48.811	46.671	-3.438	1.00	0.00	W
ATOM	4047	H2	H2O	636	23.469	66.096	0.054	1.00	0.00	W	ATOM	4083	H2	H2O	658	49.568	47.955	-3.542	1.00	0.00	W
ATOM	4048	OH2	H2O	638	38.984	67.955	-11.226	1.00	29.97	W	ATOM	4084	OH2	H2O	663	29.095	62.889	1.825	1.00	39.23	W
ATOM	4049	H1	H2O	638	38.283	67.402	-11.580	1.00	0.00	W	ATOM	4085	H1	H2O	663	29.380	62.827	2.739	1.00	0.00	W
ATOM	4050	H2	H2O	638	39.568	68.046	-11.998	1.00	0.00	W	ATOM	4086	H2	H2O	663	28.377	63.526	1.887	1.00	0.00	W
ATOM	4051	OH2	H2O	639	27.930	66.675	-7.733	1.00	43.40	W	ATOM	4087	OH2	H2O	664	27.132	25.640	7.430	1.00	50.65	W
ATOM	4052	H1	H2O	639	28.192	67.028	-6.876	1.00	0.00	W	ATOM	4088	H1	H2O	664	26.870	24.838	7.876	1.00	0.00	W
ATOM	4053	H2	H2O	639	26.975	66.791	-7.705	1.00	0.00	W	ATOM	4089	H2	H2O	664	27.001	25.362	6.496	1.00	0.00	W
ATOM	4054	OH2	H2O	643	50.619	62.802	0.813	1.00	36.55	W	ATOM	4090	OH2	H2O	665	23.367	30.554	12.167	1.00	49.69	W
ATOM	4055	H1	H2O	643	51.575	62.904	0.824	1.00	0.00	W	ATOM	4091	H1	H2O	665	24.026	30.006	11.707	1.00	0.00	W
ATOM	4056	H2	H2O	643	50.301	63.665	0.525	1.00	0.00	W	ATOM	4092	H2	H2O	665	22.941	31.016	11.438	1.00	0.00	W
ATOM	4057	OH2	H2O	646	62.897	38.367	3.759	1.00	73.55	W	ATOM	4093	OH2	H2O	666	46.015	32.192	10.179	1.00	66.86	W
ATOM	4058	H1	H2O	646	62.414	38.098	2.978	1.00	0.00	W	ATOM	4094	H1	H2O	666	46.060	31.519	9.497	1.00	0.00	W
ATOM	4059	H2	H2O	646	62.244	38.247	4.461	1.00	0.00	W	ATOM	4095	H2	H2O	666	45.411	31.827	10.833	1.00	0.00	W
ATOM	4060	OH2	H2O	650	29.587	68.480	-9.555	1.00	65.67	W	ATOM	4096	OH2	H2O	667	38.943	37.883	11.978	1.00	47.87	W
ATOM	4061	H1	H2O	650	28.846	68.630	-10.148	1.00	0.00	W	ATOM	4097	H1	H2O	667	39.367	37.487	11.188	1.00	0.00	W
ATOM	4062	H2	H2O	650	29.180	67.844	-8.936	1.00	0.00	W	ATOM	4098	H2	H2O	667	38.521	37.114	12.362	1.00	0.00	W
ATOM	4063	OH2	H2O	652	51.408	56.331	4.056	1.00	62.90	W	ATOM	4099	OH2	H2O	671	33.437	58.101	2.269	1.00	46.65	W
ATOM	4064	H1	H2O	652	50.718	56.353	3.365	1.00	0.00	W	ATOM	4100	H1	H2O	671	33.555	57.162	2.433	1.00	0.00	W
ATOM	4065	H2	H2O	652	51.052	55.671	4.648	1.00	0.00	W	ATOM	4101	H2	H2O	671	33.962	58.514	2.961	1.00	0.00	W
ATOM	4066	OH2	H2O	653	49.404	56.022	2.161	1.00	51.28	W	ATOM	4102	OH2	H2O	672	27.551	31.314	20.022	1.00	30.15	W

64/65

FIG. 5FFF

ATOM 4103	H1	H2O	672	27.929	32.042	20.533	1.00	0.00	W
ATOM 4104	H2	H2O	672	26.845	31.764	19.552	1.00	0.00	W
ATOM 4105	OH2	H2O	673	25.714	36.908	21.385	1.00	36.95	W
ATOM 4106	H1	H2O	673	24.806	37.123	21.637	1.00	0.00	W
ATOM 4107	H2	H2O	673	25.599	36.284	20.654	1.00	0.00	W
ATOM 4108	OH2	H2O	674	38.244	66.897	12.076	1.00	57.36	W
ATOM 4109	H1	H2O	674	37.773	67.536	12.626	1.00	0.00	W
ATOM 4110	H2	H2O	674	38.153	66.104	12.618	1.00	0.00	W
ATOM 4111	OH2	H2O	675	35.762	36.553	-3.986	1.00	58.40	W
ATOM 4112	H1	H2O	675	35.600	37.449	-3.677	1.00	0.00	W
ATOM 4113	H2	H2O	675	35.549	36.642	-4.923	1.00	0.00	W
ATOM 4114	OH2	H2O	676	30.689	32.814	25.675	1.00	59.30	W
ATOM 4115	H1	H2O	676	30.093	33.571	25.680	1.00	0.00	W
ATOM 4116	H2	H2O	676	31.550	33.214	25.540	1.00	0.00	W

END

65 / 65

FIG. 6A

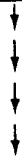
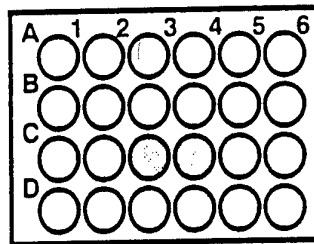

FIG. 6B

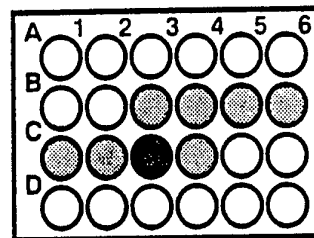
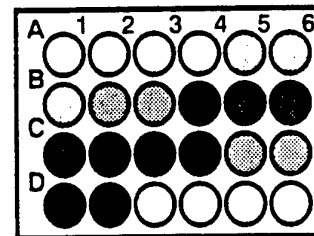

FIG. 6C



INTERNATIONAL SEARCH REPORT

International Application No
PCT/US 94/00913

A. CLASSIFICATION OF SUBJECT MATTER
IPC 5 C12N15/27 C07K3/00 C12P21/02 C07K13/00 G06F15/60

According to International Patent Classification (IPC) or to both national classification and IPC

B. FIELDS SEARCHED

Minimum documentation searched (classification system followed by classification symbols)
IPC 5 C12N C07K C12P

Documentation searched other than minimum documentation to the extent that such documents are included in the fields searched

Electronic data base consulted during the international search (name of data base and, where practical, search terms used)

C. DOCUMENTS CONSIDERED TO BE RELEVANT

Category*	Citation of document, with indication, where appropriate, of the relevant passages	Relevant to claim No.
P,X	DISSERTATION ABSTRACTS INTERNATIONAL B. vol. 54, no. 3, September 1993 page 1239 T. OSSLUND ET AL 'The structure of granulocyte-colony stimulating factor' see abstract ---	1-8
P,X	PROCEEDINGS OF THE NATIONAL ACADEMY OF SCIENCES OF USA vol. 90, June 1993, WASHINGTON US pages 5167 - 5171 C.P. HILL ET AL 'The structure of Granulocyte-colony-stimulating factor and its relationship to other growth factors' see the whole document --- -/--	1-8

Further documents are listed in the continuation of box C. Patent family members are listed in annex.

* Special categories of cited documents :

'A' document defining the general state of the art which is not considered to be of particular relevance	'T' later document published after the international filing date or priority date and not in conflict with the application but cited to understand the principle or theory underlying the invention
'E' earlier document but published on or after the international filing date	'X' document of particular relevance; the claimed invention cannot be considered novel or cannot be considered to involve an inventive step when the document is taken alone
'L' document which may throw doubts on priority claim(s) or which is cited to establish the publication date of another citation or other special reason (as specified)	'Y' document of particular relevance; the claimed invention cannot be considered to involve an inventive step when the document is combined with one or more other such documents, such combination being obvious to a person skilled in the art.
'O' document referring to an oral disclosure, use, exhibition or other means	'&' document member of the same patent family
'P' document published prior to the international filing date but later than the priority date claimed	

Date of the actual completion of the international search 11 May 1994	Date of mailing of the international search report 01-06-1994
--	--

Name and mailing address of the ISA European Patent Office, P.B. 5818 Patentaan 2 NL - 2280 HV Rijswijk Tel. (+31-70) 340-2040, Tx. 31 651 epo nl, Fax: (+31-70) 340-3016	Authorized officer Le Cornec, N
---	--

INTERNATIONAL SEARCH REPORT

International Application No
PCT/US 94/00913

C.(Continuation) DOCUMENTS CONSIDERED TO BE RELEVANT		
Category *	Citation of document, with indication, where appropriate, of the relevant passages	Relevant to claim No.
X	CELL STRUCTURE AND FUNCTION vol. 17, no. 1 , February 1992 pages 61 - 65 MASAHARU ISHIKAWA ET AL 'The substitution of Cysteine 17 of recombinant human G-CSF with Alanine greatly enhanced its stability' see the whole document ---	43
X	WO,A,87 01132 (KIRIN-AMGEN, INC.) 26 February 1987 see claims; examples 7-9 & US,A,4 810 643 (KIRIN-AMGEN, INC.) 7 March 1989 cited in the application ---	9
X	WO,A,89 05824 (GENETICS INSTITUTE, INC.) 29 June 1989 * see the whole document especially page 17 table 2 , page 21 lines 16-19 and page 22 lines 25-37 * & US,A,4 904 584 (GENETICS INSTITUTE) 27 February 1990 cited in the application ---	17-22
A	BIOCHEMICAL AND BIOPHYSICAL RESEARCH COMMUNICATIONS vol. 159, no. 1 , 28 February 1989 , DULUTH, MINNESOTA US pages 103 - 111 TETSURO KUGA ET AL 'Mutagenesis of human granulocyte colony stimulating factor' cited in the application see the whole document ---	9-59
Y	EP,A,0 344 796 (CHUGAI SEIYAKU KABUSHIKI KAISHA) 6 December 1989 cited in the application see the whole document ---	1-8
Y	BIOCHEMISTRY vol. 30 , 1991 , EASTON, PA US pages 4151 - 4159 L. ABRAHMSEN ET AL 'Engineering subtilisin and its sustrates for efficient ligation of peptide bonds in aqueous solution' * see the whole document especially page 4152 right column , page 4153 right column and the discussion * ---	1-8

2

-/--

INTERNATIONAL SEARCH REPORT

 International Application No
 PCT/US 94/00913

C.(Continuation) DOCUMENTS CONSIDERED TO BE RELEVANT		
Category *	Citation of document, with indication, where appropriate, of the relevant passages	Relevant to claim No.
Y	SCIENCE vol. 258 , 20 November 1992 , LANCASTER, PA US pages 1358 - 1362 J. PANDIT ET AL 'Three-dimensional Structure of dimeric human recombinant Macrophage Colony-Stimulating Factor' cited in the application see the whole document ---	1-8
P,A	WO,A,93 25687 (CHIRON CORPORATION) 23 December 1993 see page 16, line 11 - page 17, line 5 see examples 1,9,10,11,13 see appendix 1 see claims ---	1-8
P,X	JOURNAL OF CELLULAR BIOCHEMISTRY SUPPL 0 no. 17B , 26 JANUARY-10 FEBRUARY 1993 page 78 J. E. LAYTON ET AL 'Interaction of G-CSF with its receptor : Dissociation of biological activity and Receptor binding' * see abstract E 225 * ---	27, 32, 34-38, 51-53
A	EP,A,0 456 200 (BOEHRINGER MANNHEIM GMBH) 13 November 1991 ---	
A	JOURNAL OF APPLIED CRYSTALLOGRAPHY vol. 20 , 1987 pages 366 - 373 M.J. COX ET AL 'Experiments with automated protein crystallization' cited in the application ---	
T	POUR LA SCIENCE vol. 183 , January 1993 pages 76 - 82 A. OLSON ET AL 'Voir les Molécules biologiques' ---	
Y	PROTEIN ENGINEERING 1987 , ALAN R. LISS, INC. pages 35 - 44 M. KARPLUS 'The prediction and Analysis of mutant structures' see the whole document ---	1-8
A	WO,A,88 01775 (GENEX CORPORATION) 10 March 1988 -----	

INTERNATIONAL SEARCH REPORT

Information on patent family members

Int. onal Application No PCT/US 94/00913

Patent document cited in search report	Publication date	Patent family member(s)	Publication date
WO-A-8701132	26-02-87	US-A- 4810643	07-03-89
		AU-A- 6334686	10-03-87
		AU-A- 6937391	02-05-91
		EP-A, B 0237545	23-09-87
		EP-A- 0396158	07-11-90
		JP-A- 2042998	13-02-90
		JP-C- 1729335	29-01-93
		JP-A- 2031675	01-02-90
		JP-B- 4002599	20-01-92
		JP-A- 6090751	05-04-94
		JP-B- 3031437	07-05-91
		JP-T- 63500636	10-03-88
		US-A- 4999291	12-03-91
		BG-A- 60169	15-11-93
US-A-4810643	07-03-89	AU-A- 6334686	10-03-87
		BG-A- 60169	15-11-93
		EP-A, B 0237545	23-09-87
		EP-A- 0396158	07-11-90
		JP-A- 2042998	13-02-90
		JP-C- 1729335	29-01-93
		JP-A- 2031675	01-02-90
		JP-B- 4002599	20-01-92
		JP-A- 6090751	05-04-94
		WO-A- 8701132	26-02-87
		AU-A- 6937391	02-05-91
		JP-B- 3031437	07-05-91
		JP-T- 63500636	10-03-88
		US-A- 4999291	12-03-91
WO-A-8905824	29-06-89	US-A- 4904584	27-02-90
		AU-A- 2911189	19-07-89
		EP-A- 0355142	28-02-90
US-A-4904584	27-02-90	AU-A- 2911189	19-07-89
		EP-A- 0355142	28-02-90
		WO-A- 8905824	29-06-89
EP-A-0344796	06-12-89	JP-A- 2209895	21-08-90

INTERNATIONAL SEARCH REPORT

Information on patent family members

International Application No PCT/US 94/00913
--

Patent document cited in search report	Publication date	Patent family member(s)	Publication date
WO-A-9325687	23-12-93	NONE	
EP-A-0456200	13-11-91	DE-A- 4014750 AU-B- 631312 AU-A- 7638091 CN-A- 1057862 JP-A- 4225998 KR-B- 9400757	14-11-91 19-11-92 14-11-91 15-01-92 14-08-92 29-01-94
WO-A-8801775	10-03-88	US-A- 4704692 EP-A- 0279848 US-A- 4881175	03-11-87 31-08-88 14-11-89