

(19) World Intellectual Property  
Organization  
International Bureau



(43) International Publication Date  
18 March 2004 (18.03.2004)

PCT

(10) International Publication Number  
WO 2004/021904 A3

- (51) International Patent Classification<sup>7</sup>: A61B 17/72
- (21) International Application Number: PCT/EP2003/009678
- (22) International Filing Date: 1 September 2003 (01.09.2003)
- (25) Filing Language: English
- (26) Publication Language: English
- (30) Priority Data: 02019635.8 3 September 2002 (03.09.2002) EP
- (71) Applicant and  
(72) Inventor: PENNIG, Dietmar [DE/DE]; Hans-Driesch-Strasse 12, 50935 Koln (DE).
- (74) Agents: BOTTI, Mario et al.; Botti & Ferrari S.r.l., Via Locatelli, 5, I-20124 Milano (IT).
- (81) Designated States (*national*): AE, AG, AL, AM, AT, AU, AZ, BA, BB, BG, BR, BY, BZ, CA, CH, CN, CO, CR, CU, CZ, DE, DK, DM, DZ, EC, EE, ES, FI, GB, GD, GE, GH, GM, HR, HU, ID, IL, IN, IS, JP, KE, KG, KP, KR, KZ, LC, LK, LR, LS, LT, LU, LV, MA, MD, MG, MK, MN, MW, MX, MZ, NI, NO, NZ, OM, PG, PH, PL, PT, RO, RU, SC, SD, SE, SG, SK, SL, SY, TJ, TM, TN, TR, TT, TZ, UA, UG, US, UZ, VC, VN, YU, ZA, ZM, ZW.
- (84) Designated States (*regional*): ARIPO patent (GH, GM, KE, LS, MW, MZ, SD, SL, SZ, TZ, UG, ZM, ZW), Eurasian patent (AM, AZ, BY, KG, KZ, MD, RU, TJ, TM), European patent (AT, BE, BG, CH, CY, CZ, DE, DK, EE, ES, FI, FR, GB, GR, HU, IE, IT, LU, MC, NL, PT, RO, SE, SI, SK, TR), OAPI patent (BF, BJ, CF, CG, CI, CM, GA, GN, GQ, GW, ML, MR, NE, SN, TD, TG).
- Published:  
— with international search report

[Continued on next page]

(54) Title: SURGICAL NAIL AND SCREW FIXATION SYSTEM

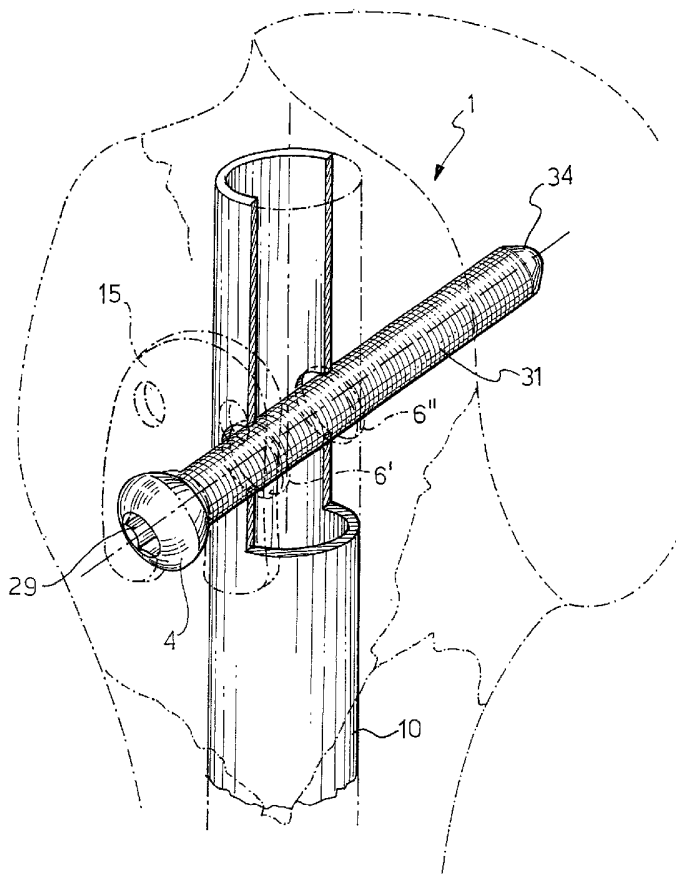

(57) Abstract: The present invention relates to a nail and screw system (1) for improving the fixation of proximal fractures of the humerus, including at least a Numeral nail (10) to be inserted in a Numeral shaft (9) and comprising at least a proximal transversal hole (5) for the passage of a corresponding locking screw (3), the screw (3) having a screw head (4) and a screw body (31). Advantageously, the nail is cannulated and the transversal hole (5) comprises a couple of opposite holes (6', 6'') on opposite wall of the cannulated nail (10); the hole (6') closer to the screw head (4) has an internal partially threaded portion (28) and the corresponding screw (3) has an outside thread diameter smaller than the diameter of said at least one transversal hole (27) that receives such a screw. Said nail is cannulated and said transversal hole comprises a couple of opposite holes (6', 6'') on opposite wall of the cannulated nail (10) and the hole (6') closer to the screw head (4) includes said partially threaded portion (28).

WO 2004/021904 A3



— *before the expiration of the time limit for amending the claims and to be republished in the event of receipt of amendments*

*For two-letter codes and other abbreviations, refer to the "Guidance Notes on Codes and Abbreviations" appearing at the beginning of each regular issue of the PCT Gazette.*

**(88) Date of publication of the international search report:**

13 May 2004

# INTERNATIONAL SEARCH REPORT

International Application No  
PCT/EP 03/09678

**A. CLASSIFICATION OF SUBJECT MATTER**  
IPC 7 A61B17/72

According to International Patent Classification (IPC) or to both national classification and IPC

**B. FIELDS SEARCHED**

Minimum documentation searched (classification system followed by classification symbols)  
IPC 7 A61B

Documentation searched other than minimum documentation to the extent that such documents are included in the fields searched

Electronic data base consulted during the international search (name of data base and, where practical, search terms used)

EPO-Internal

**C. DOCUMENTS CONSIDERED TO BE RELEVANT**

Category °	Citation of document, with indication, where appropriate, of the relevant passages	Relevant to claim No.
X	FR 2 784 283 A (FOURNITURES HOSPITALIERES IND) 14 April 2000 (2000-04-14) the whole document -----	1, 4
A	US 6 355 043 B1 (ADAM MICHAEL) 12 March 2002 (2002-03-12) claim 3; figure 3 -----	1, 4, 5
A	US 3 709 218 A (HALLORAN W) 9 January 1973 (1973-01-09) abstract; figure 11 -----	1, 6, 7
A	DE 89 07 443 U (AESCULAP AG) 14 September 1989 (1989-09-14) the whole document -----	1, 6

Further documents are listed in the continuation of box C.

Patent family members are listed in annex.

° Special categories of cited documents :

- \*A\* document defining the general state of the art which is not considered to be of particular relevance
- \*E\* earlier document but published on or after the international filing date
- \*L\* document which may throw doubts on priority claim(s) or which is cited to establish the publication date of another citation or other special reason (as specified)
- \*O\* document referring to an oral disclosure, use, exhibition or other means
- \*P\* document published prior to the international filing date but later than the priority date claimed

- \*T\* later document published after the international filing date or priority date and not in conflict with the application but cited to understand the principle or theory underlying the invention
- \*X\* document of particular relevance; the claimed invention cannot be considered novel or cannot be considered to involve an inventive step when the document is taken alone
- \*Y\* document of particular relevance; the claimed invention cannot be considered to involve an inventive step when the document is combined with one or more other such documents, such combination being obvious to a person skilled in the art.
- \* & \* document member of the same patent family

Date of the actual completion of the international search

9 March 2004

Date of mailing of the international search report

18/03/2004

Name and mailing address of the ISA

European Patent Office, P.B. 5818 Patentlaan 2  
NL - 2280 HV Rijswijk  
Tel. (+31-70) 340-2040, Tx. 31 651 epo nl,  
Fax: (+31-70) 340-3016

Authorized officer

Hansen, S

**INTERNATIONAL SEARCH REPORT**

International Application No  
PCT/EP 03/09678

Patent document cited in search report		Publication date	Patent family member(s)	Publication date
FR 2784283	A	14-04-2000	FR 2784283 A1	14-04-2000
US 6355043	B1	12-03-2002	EP 1033111 A1	06-09-2000
US 3709218	A	09-01-1973	NONE	
DE 8907443	U	14-09-1989	DE 8907443 U1	14-09-1989