

(19) World Intellectual Property
Organization
International Bureau



(43) International Publication Date
19 February 2004 (19.02.2004)

PCT

(10) International Publication Number
WO 2004/015216 A1

(51) International Patent Classification⁷: **E04B 5/00**

(21) International Application Number:
PCT/US2003/005739

(22) International Filing Date: 25 February 2003 (25.02.2003)

(25) Filing Language: English

(26) Publication Language: English

(71) Applicant (for all designated States except US): **SO-
PREMA U.S.A. INC.** [US/US]; 310 Quadral Drive,
Wadsworth, OH 44281 (US).

(72) Inventors; and

(75) Inventors/Applicants (for US only): **HALLENBECK,
Charles N.** [US/US]; 2920 Millboro Road, Silver Lake,
OH 44224 (US). **LORENZO, Gilbert** [US/US]; Village
Point Apartments, Bldg. 333, Apt. C, Akron, OH 44313
(US).

(74) Agent: **MINNS, Michael H.**; Hahn Loeser & Parks LLP,
Twin Oaks Estate, 1225 West Market Street, Akron, OH
44313 (US).

(81) Designated States (national): AE, AG, AL, AM, AT, AU,
AZ, BA, BB, BG, BR, BY, BZ, CA, CH, CN, CO, CR, CU,
CZ, DE, DK, DM, DZ, EC, EE, ES, FI, GB, GD, GE, GH,
GM, HR, HU, ID, IL, IN, IS, JP, KE, KG, KP, KR, KZ, LC,
LK, LR, LS, LT, LU, LV, MA, MD, MG, MK, MN, MW,
MX, MZ, NO, NZ, OM, PH, PL, PT, RO, RU, SC, SD, SE,
SG, SK, SL, TJ, TM, TN, TR, TT, TZ, UA, UG, US, UZ,
VC, VN, YU, ZA, ZM, ZW.

(84) Designated States (regional): ARIPO patent (GH, GM,
KE, LS, MW, MZ, SD, SL, SZ, TZ, UG, ZM, ZW),
Eurasian patent (AM, AZ, BY, KG, KZ, MD, RU, TJ, TM),
European patent (AT, BE, BG, CH, CY, CZ, DE, DK, EE,
ES, FI, FR, GB, GR, HU, IE, IT, LU, MC, NL, PT, SE, SI,
SK, TR), OAPI patent (BF, BJ, CF, CG, CI, CM, GA, GN,
GQ, GW, ML, MR, NE, SN, TD, TG).

Published:

- with international search report
- before the expiration of the time limit for amending the claims and to be republished in the event of receipt of amendments
- upon request of the applicant, before the expiration of the time limit referred to in Article 21(2)(a)

For two-letter codes and other abbreviations, refer to the "Guidance Notes on Codes and Abbreviations" appearing at the beginning of each regular issue of the PCT Gazette.

(54) Title: ROOFING MEMBRANE

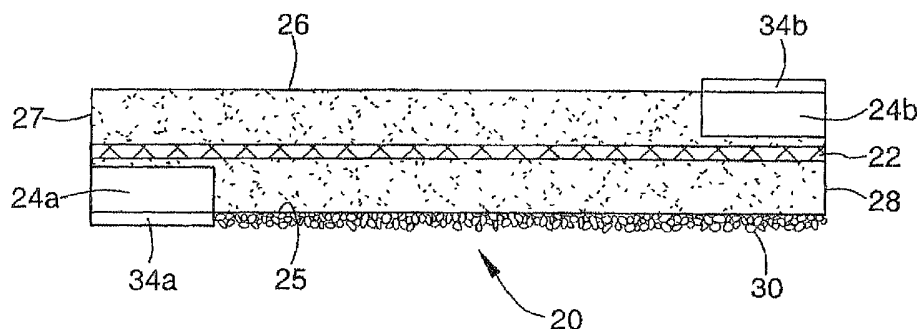

(57) Abstract: A bituminous roofing membrane (20) that uses self-adhesive to seal one roofing membrane to an adjacent overlapping roofing membrane. The roofing membrane uses asphalt modified with a styrene-butadiene-styrene copolymer. Each section of roofing membrane has two portions of self-adhesive, a first longitudinal strip on a lower surface (24b) and a second longitudinal strip on an upper surface (24a), one strip of self-adhesive is along the left side of the membrane and the other strip of self-adhesive is along the right side of the membrane. The portions of self-adhesive are asphalt modified with a styrene-isoprene-styrene copolymer. The first strip of self-adhesive on the lower surface of one section of roofing membrane is placed to overlap the second strip of self-adhesive on the upper surface of a second section of roofing membrane.

WO 2004/015216 A1

ROOFING MEMBRANE

BACKGROUND OF THE INVENTION

[0001] This invention relates generally to a system for the sealing of roofs and more particularly to a roofing membrane that uses a self-adhesive to adhere one roofing membrane to an adjacent membrane.

[0002] Various systems have been proposed for the sealing of roofs. One frequently used system consists of applying a bituminous or asphalt coating in two layers, where the first layer is mechanically fixed to the support to be protected and the second layer is typically welded with a welding torch to the first layer. However, such a system is not always convenient since torch welding requires specialized manpower and has certain risks, such as the support being protected being flammable.

[0003] The bituminous layers are frequently modified bitumens that use a traditional waterproofing medium—asphalt—that is typically modified with atactic polypropylene (APP), styrene-butadiene-styrene (SBS), synthetic rubber, and other agents to enhance the asphalt properties. The modified bitumen sheets are typically reinforced with fiberglass or polyester, or a combination of the two. Surfacing, if applied, includes granules, slag, aluminum, or copper.

[0004] Systems typically include a minimum of one base-ply and the top modified bitumen sheet. Additional plies of roofing felt or modified sheets may be used to add strength and longevity to the system. Some manufacturers recommend the use of a single modified bitumen sheet under certain circumstances.

[0005] Application methods for polymer modified bituminous sheets include torching, hot air welding, hot asphalt, cold adhesives, and self-adhering sheets.

[0006] The foregoing illustrates limitations known to exist in present roofing systems. Thus, it is apparent that it would be advantageous to provide an alternative directed to overcoming one or more of the limitations set forth

above. Accordingly, a suitable alternative is provided including features more fully disclosed hereinafter.

SUMMARY OF THE INVENTION

[0007] In one aspect of the present invention, this is accomplished by providing a base roofing membrane comprising: a layer of asphalt having a length, a width, a first side, a second side, an upper surface and a lower surface; a reinforcement within the asphalt layer; and means for self-adhering the layer of asphalt to another substrate.

[0008] In another aspect of the present invention, this is accomplished by providing a roofing membrane comprising: a base roofing membrane comprising: a layer of asphalt having a length, a width, a first side, a second side, an upper surface and a lower surface, the layer of asphalt including a styrene-butadiene-styrene copolymer; a reinforcement within the asphalt layer; a longitudinally extending portion of the asphalt layer upper surface adjacent the first side having self-adhesive properties, the self-adhesive portion extending only partway across the width of the asphalt layer, the portion of the asphalt layer having self-adhesive properties comprising asphalt and a styrene-isoprene-styrene copolymer, a layer of granular material, such as sand, covering the asphalt layer upper surface except for the self-adhesive portion, a layer of asphalt primer on the granular material; and a top membrane adhered to the base roofing membrane, the top membrane comprising: a layer of asphalt having a length, a width, a first side, a second side, an upper surface and a lower surface, the top membrane layer of asphalt including a styrene-butadiene-styrene copolymer; the top membrane asphalt layer lower surface having self-adhesive properties; and a protective material covering the upper surface of the top membrane asphalt layer except for a longitudinally extending portion adjacent a top membrane side, the top membrane self-adhesive properties comprising a styrene-isoprene-styrene copolymer.

[0009] In yet another aspect of the present invention, this is accomplished by providing a method for installing roofing membranes on a roof comprising the steps of:

(a) providing a base roofing membrane comprising: a layer of asphalt having a length, a width, a first side, a second side, an upper surface and a lower surface; a longitudinally extending portion of the asphalt layer upper surface adjacent a side having self-adhesive properties, the self-adhesive portion extending only partway across the width of the asphalt layer; and a release film on the self-adhesive portion;

(b) placing a section of base roofing membrane on the roof;

(c) removing the release film from the upper surface self-adhesive portion;

(d) attaching the section of base roofing membrane to the roof using a plurality of mechanical fasteners inserted through the upper surface self-adhesive portion;

(e) placing an additional section of base roofing membrane on the roof, the lower surface of the additional section of base roofing membrane overlapping, and being adhered to, the upper surface self-adhesive portion of the section of base roofing membrane;

(f) removing the release film from the upper surface of the additional section of base roofing membrane;

(g) attaching the additional section of base roofing membrane to the roof using a plurality of mechanical fasteners inserted through the upper surface self-adhesive portion; and

(i) repeating steps (e) through (g) with each additional section of base roofing membrane overlapping, and being adhered to, the prior additional section of base roofing membrane.

[0010] In yet another aspect of the present invention, this is accomplished by providing a reinforcement plate having: a central opening therein for receiving a fastener therein to secure the reinforcement plate to the roof; and a plurality of circumferentially spaced holes therein.

[0011] The foregoing and other aspects will become apparent from the following detailed description of the invention when considered in conjunction with the accompanying drawing figures.

BRIEF DESCRIPTION OF THE DRAWING FIGURES

[0012] FIG. 1 is a cross-sectional view of a base roofing membrane according to the present invention;

FIG. 1A is a cross-sectional view of a second embodiment of a base roofing membrane according to the present invention;

FIG. 1B is a cross-sectional view of a third embodiment of a base roofing membrane according to the present invention;

FIG. 1C is a cross-sectional view of a fourth embodiment of a base roofing membrane according to the present invention;

FIG. 1D is a cross-sectional view of a fifth embodiment of a base roofing membrane according to the present invention;

FIG. 1E is a cross-sectional view of a sixth embodiment of a base roofing membrane according to the present invention;

FIG. 2 is a cross-section of overlapping base roofing membrane taken on line 2-2 of FIG. 3;

FIG. 3 is a top plan view illustrating a roof covered with the roofing membranes of the present invention;

FIG. 4 is cross-sectional view of an alternate embodiment of a base roofing membrane;

FIG. 5 is cross-sectional view of a second alternate embodiment of a base roofing membrane;

FIG. 6 is a cross-sectional view of a top membrane for use with the base roofing membrane;

FIG. 6A is a cross-sectional view of a second embodiment of a top membrane for use with the base roofing membrane;

FIG. 6B is a cross-sectional view of a third embodiment of a top membrane for use with the base roofing membrane;

FIG. 6C is a cross-sectional view of a fourth embodiment of a top membrane for use with the base roofing membrane;

FIG. 7 is a cross-sectional view taken on line 7-7 of FIG. 3, the thicknesses of the roofing membranes are exaggerated and the width of the roofing membranes are reduced to more clearly show the overlapping relationships;

FIG. 8 is a plan view of a reinforcement plate for use with the base roofing membrane shown in FIG. 1;

FIG. 9 is a cross-sectional of the reinforcement plate taken on line 9-9 of FIG. 8; and

FIG. 10 is a cross-sectional of a portion of the reinforcement plate taken on line 10-10 of FIG. 8.

DETAILED DESCRIPTION

[0013] FIG. 3 shows a typical roof 10 formed using a base roofing membrane 20 of the present invention and a top membrane 40 of the present invention. A typical roof 10 has a base support of steel deck 12, also shown in FIG. 2. Usually insulation 14 is installed over steel deck 12. Overlapping layers of base roofing membrane 20 are next laid over the insulation 14. One layer of base roofing membrane 20 is adhered to the adjacent layer of base roofing membrane by overlapping self-adhesive portions 24a, 24b of the base roofing membranes 20. The edges of base roofing membrane 20 are mechanically fastened to the steel deck 12 using a plurality of reinforcement plates 60 and fasteners 62. Reinforcement plates 60 and fasteners 62 are normally placed in self-adhesive portion 24b. Usually, only the lower layer of base roofing membrane 20 is mechanically fastened to the steel deck 10 (See FIGS. 2 and 7). Base roofing membrane 20 is placed transverse to steel deck 12. Finally, a layer of top membrane 40 is placed over base roofing mem-

brane 20. One section of top membrane 40 usually overlaps portions of two base roofing membranes 20. Top membrane 40 can be adhered to base roofing membrane 20 by the adherence of one layer of SBS modified bitumen to an adjacent layer of SBS modified bitumen. In addition, top membrane 40 can include a self-adhesive portion 42. Top membrane 40 could also be adhered to base roofing membrane by torching, using cold adhesive, using hot adhesive, or hot air welding.

[0014] Base roofing membrane 20 and top membrane 40 can be pre-fabricated modified bituminous sheets reinforced with polyester, fiberglass or a composite of both polyester and fiberglass, that can be applied to a substrate without the use of accessory cement and/or adhesive. The membrane is composed of asphalt and a polymer dispersion wherein the polymer forms the continuous phase and the asphalt forms the discontinuous phase. The modified bituminous membrane is made up of asphalt, polymer, filler, fire-retardant, tackifying agent, resin, oil, and/or surface active ingredient. The asphalt component may include any material meeting ASTM D288. The polymer component is composed of styrene as one co-monomer and the other co-monomer being an olefin (butadiene rubber), acrylate, amine, and/or mercaptan. The filler is a material that is inert under conditions of use and serves to occupy volume and improves physical characteristics of the membrane. The fire-retardant is a component that improves flame spread characteristics of the membrane. The tackifying agent or resin is a component that improves adhesion of the sheet to the substrate. The oil and surfactant components aid in the dispersion of the asphalt into the polymer matrix. The choices for these various components are the choices typically used by one skilled in the art of roofing membranes for the expected service conditions of the roofing membrane, except as specifically described elsewhere herein.

[0015] FIG. 1 shows a horizontal cross-section of base roofing membrane 20. Base roofing membrane 20 consists primarily of reinforcement 22 within a layer of polymer modified bitumen asphalt. Preferably, the layer of asphalt includes a styrene-butadiene-styrene copolymer (SBS asphalt). Other

polymeric additives could be atactic polypropylene (APP), synthetic rubber or similar materials. The reinforcement 22 can be formed from a variety of materials, such as fiberglass or polyester, or a combination of the two. Preferably, a non-woven polyester is used for the reinforcement 22. Upper surface 26, except for self-adhesive portion 24b, preferably, consists of exposed SBS asphalt.

[0016] Base roofing membrane 20 includes two portions of self-adhesive 24a, 24b. A first longitudinally extending strip or side lap of self-adhesive 24a is positioned on the lower surface 25 of the base roofing membrane 20 adjacent the left or first side 27 of the base roofing membrane 20. The first strip of self-adhesive 24a extends only partway across the width of base roofing membrane 20. A second longitudinally extending strip or side lap of self-adhesive 24b is positioned on the upper surface 26 of the base roofing membrane 20 adjacent the right or second side 28 of the base roofing membrane. The second strip of self-adhesive 24b extends only partway across the width of base roofing membrane. Each strip of self-adhesive 24a, 24b extends across the width of base roofing 20 such that one strip of self-adhesive 24a, 24b does not vertically overlap the other strip of self-adhesive 24a, 24b. Typically, the width of base roofing membrane is 1 meter and the width of each strip of self-adhesive 24a, 24b is about 12 centimeters. Each strip of self-adhesive 24b, 24a can be covered with a release strip or paper 34a, 34b.

[0017] The self-adhesive properties for self-adhesive strips or portions 24a, 24b can be provided by adding a layer of self-adhesive on the surface of base roofing membrane 20, or by adding a self-adhesive to the raw asphalt. Preferably, self-adhesive portions 24a, 24b are asphalt modified with a styrene-isoprene-styrene copolymer (SIS bitumen). In one method for forming self-adhesive strips 24a, 24b, a strip of the SBS asphalt is scrapped away from the surface 25, 26 and a strip of SIS asphalt is applied in its place.

[0018] In one embodiment, the lower surface 25 of base roofing membrane 20 includes a layer 30 of granular material, such as sand, to prevent

adjacent surfaces of base roofing membrane 20 from sticking to one another when base roofing membrane 20 is rolled into a roll. Granular material 30 extends from the right side 28 of base roofing membrane to an inner edge of self-adhesive strip 24a. Rather than granular material 30, a release sheet (not shown) could be used. This release sheet could be separate from release strip 34a or a single sheet of release material could be used for the entire lower surface 25 of base roofing membrane 20. In another embodiment, shown in FIG. 1B, the upper surface 26 of base roofing membrane 20 includes a layer 30 of granular material, such as sand, to prevent adjacent surfaces of base roofing membrane 20 from sticking to one another when base roofing membrane 20 is rolled into a roll. After base roofing membrane 20 has been installed, an asphaltic primer, such as SBS, can be placed over sand layer 30 to adhere top membrane 40 to base roofing membrane 20.

[0019] In another embodiment of base roofing membrane 20, shown in FIG. 1A, only one surface, shown in FIG. 1A as upper surface 26, has a self-adhesive portion 24b. In this embodiment, lower surface 25 does not have a layer 30 of granular material. A layer 34c of release material is provided on upper surface 26, extending across the SBS asphalt and the self-adhesive SIS bitumen 24b. In this embodiment, the self-adhesive portion 24b of one piece of base roofing material 20 adheres to the lower SBS asphalt surface of the overlying piece of base roofing material 20.

[0020] A further embodiment of base roofing membrane 20 is shown in FIG. 1C. Rather than a strip or side lap of self-adhesive, the entire lower surface 25 has self-adhesive properties, preferably by adding an SIS copolymer to the lower portion 24 of the asphaltic layer. As an alternative to the embodiment shown in FIG. 1C, the entire upper surface 26 can have self-adhesive properties, preferably by placing a layer 24 of asphalt with an SIS co-polymer on the upper surface 26 of base roofing membrane 20, as shown in FIG. 1E. Another embodiment of base roofing membrane is shown in FIG. 1D, where the entire asphaltic layer has self-adhesive properties, preferably by including an SIS copolymer 24 throughout the entire asphaltic layer.

[0021] An alternate embodiment of base roofing membrane 20' is shown in FIG. 4. In base roofing membrane 20', reinforcement 22 is divided into two sections. A first section of reinforcement 22a, which is the same as described above for base roofing membrane 20, and a second section of reinforcement 22. Reinforcement 22 has the same width as second or upper self-adhesive strip 24b. Reinforcement 22 has a higher tear resistance and strain energy than reinforcement 22. One reinforcement 22 that can be used is Kevlar® aramid fabric.

[0022] A third embodiment of base roofing membrane 20" is shown in FIG. 5. Base roofing membrane 20" is used when only a single ply roofing is desired. Base roofing membrane 20" is similar to base roofing membrane 20 described above, except that a layer of protective material 36 is provided on the upper surface 26 of base roofing membrane 20". Typically, protective material 36 is a granular material. However, other protective materials such as aluminum, can be used. No top membrane 40 is used with base roofing membrane 20".

[0023] One embodiment of top membrane 40 is shown in FIG. 6. Top membrane 40 is similar to base roofing membrane 20 in that it consists primarily of asphalt with a styrene-butadiene-styrene copolymer (SBS asphalt). Top membrane 40 preferably includes reinforcement 47, but can be used without any reinforcing material. A portion of the upper surface 44 of top membrane 40 is a longitudinal strip of self-adhesive 42 adjacent the right or second side 46 of top membrane 40. Preferably, a release strip 48 covers the strip of self-adhesive 42. Although the strip of self-adhesive 42 can be a self-adhesive layer on upper surface 44, self-adhesive portion 42 preferably consists of asphalt containing a styrene-isoprene-styrene copolymer (SIS asphalt). The lower surface 43 of top membrane preferably consists of exposed SBS asphalt. An optional layer of protective material 50, such as a granular material, aluminum, copper, etc., on upper surface 44 of top membrane 40 is shown in FIG. 6 and extends from the left side or first side 45 of top membrane to an inside edge of self-adhesive portion 42. Alternatively, self-

adhesive portion 42 could be on lower surface 43 adjacent first side 45 (as shown in FIG. 6B) or two-self adhesive portions 42, 42a can be used, one on upper surface 44 adjacent the right side of second side 46 of top membrane 40 and one on lower surface 43 adjacent a second edge 47 of top membrane 40 (as shown in FIG. 6A). In another embodiment, shown in FIG. 6C, the entire lower surface 43 has self-adhesive properties, preferably by using an SIS copolymer 42.

[0024] Top membrane 40, as shown in FIG. 6C, is produced by forming a central portion 49a of SBS asphalt around reinforcement 47. A lower portion 49b of self-adhesive asphalt is formed below the central SBS asphalt portion 49a. An upper portion 49c of SBS asphalt is formed above the central portion 49a. Central asphalt portion 49a and upper asphalt portion 49c can be formed as a single layer or separate layers.

[0025] When installed, as shown in FIG. 7, the lower surface left side 45 of an adjacent section of top membrane 40 overlaps and is adhered to the self-adhesive portion 42 of a prior section of top membrane 40. In addition, the exposed SBS asphalt on the lower surface 43 of top membrane 40 adheres to the exposed SBS asphalt on the upper surface 26 of base roofing membrane 20. Rather than using self-adhesive portion 42, or in addition to using self-adhesive portion 42, top membrane 40 can be adhered to base roofing membrane 20 by adhesion of one exposed styrene-butadiene-styrene asphalt surface to another exposed styrene-butadiene-styrene asphalt surface.

[0026] The preferred embodiment of a built-up roofing membrane according to the present invention comprises a base roofing membrane 20 as shown in FIG. 1B with top membrane 40 as shown in FIG. 6C. After installation of base roofing membrane 20, an asphalt primer is spread over the sand layer 30 to allow the self-adhesive lower surface 43 of top membrane 40 to adhere to the base roofing membrane 20.

[0027] Alternatively, the top membrane 40 shown in FIG. 6 can be used with the base roofing membrane 20 shown in FIG. 1B. For this built-up roof-

ing membrane, a cold adhesive is used to adhere top membrane 40 to base roofing membrane 20.

[0028] FIGS. 8 through 10 illustrate a reinforcement plate 60 for use with base roofing membrane 20. Reinforcement plate 60 is a circular plate having a central fastener opening 64 surrounded by a hub 66. Around hub 66 are a plurality of holes 68. Holes 68 allow the upper surface 26 of one section of base roofing membrane 20 to be exposed to the lower surface 25 of an overlying section of base roofing membrane 20. This increases the adherence of one section of base roofing membrane 20 to the adjacent section of base roofing membrane 20 in the area where reinforcement plate 60 is installed. Reinforcement plate 60 also includes a plurality of compression V's 69 that extend downward below plate 60. As fastener 62 is rotated clockwise to fasten plate 60 and the underlying base roofing membrane 20 to steel deck 12, plate 60 will also rotate clockwise. Compression V's 69 compress base roofing membrane 20 as plate 60 rotates. As plate 60 continues to rotate, the compressed base roofing membrane 20 will encounter a hole 68 and expand upward into hole 68. The expansion of base roofing membrane 20 into holes 68 along with the adherence of top membrane 40 to the portions of base roofing membrane 20 sticking up into holes 68 help prevent counterclockwise rotation of plate 60. Counterclockwise rotation of plate 60 can cause fastener 62 to also rotate and possibly unscrew from steel deck 12 and loosen plate 60, which can lead to premature failure of the roofing system. Preferably, compression V's 69 have a V-shape like the bow of a boat as shown in FIGS. 8 through 10. Other shapes, such as a rounded half dome can be used in place of compression V's 69.

Having described the invention, what is claimed is:

1. A base roofing membrane comprising:
 - a layer of asphalt having a length, a width, a first side, a second side, an upper surface and a lower surface;
 - a reinforcement within the asphalt layer; and
 - means for self-adhering the layer of asphalt to another section of base roofing membrane.
2. The base roofing membrane according to claim 1, wherein the means for self-adhering comprises a first longitudinally extending portion of the asphalt layer upper surface adjacent the first side having self-adhesive properties, the first self-adhesive portion extending only partway across the width of the asphalt layer.
3. The base roofing membrane according to claim 2, wherein the means for self-adhering further comprises: a second longitudinally extending portion of the asphalt layer lower surface adjacent the second side having self-adhesive properties, the second self-adhesive portion extending only partway across the width of the asphalt layer.
4. The base roofing membrane according to claim 3, wherein the first self-adhesive portion does not vertically overlap the second self-adhesive portion.
5. The base roofing membrane according to claim 3, further comprising:
 - a layer of granular material covering the asphalt layer lower surface except for the second self-adhesive portion.
6. The base roofing membrane according to claim 5, further comprising:
 - a layer of granular material covering the asphalt layer upper surface except for the first self-adhesive portion.

7. The base roofing membrane according to claim 3, wherein each self-adhesive portion comprises a self-adhesive adhered to the surfaces of the asphalt layer.

8. The base roofing membrane according to claim 3, wherein each self-adhesive portion comprises a portion of the asphalt layer having self-adhesive properties.

9. The base roofing membrane according to claim 8, wherein the portions of the asphalt layer having self-adhesive properties comprise asphalt and a styrene-isoprene-styrene copolymer.

10. The base roofing membrane according to claim 3, further comprising:
a release film on each self-adhesive portion.

11. The base roofing membrane according to claim 3, wherein the reinforcement comprises:

a longitudinally extending first reinforcement portion co-extensive with the first self-adhesive portion; and

a longitudinally extending second reinforcement portion between the first reinforcement portion and the first side,

the properties of the first reinforcement portion being different from the properties of the second reinforcement portion.

12. The base roofing membrane according to claim 11, wherein the first reinforcement portion has a higher tear resistance than the second reinforcement portion.

13. The base roofing membrane according to claim 3, wherein the reinforcement is a non-woven reinforcement.

14. The base roofing membrane according to claim 3, wherein the reinforcement is a non-woven polyester.
15. The base roofing membrane according to claim 2, further comprising:
a layer of granular material covering the asphalt layer upper surface except for the first self-adhesive portion.
16. The base roofing membrane according to claim 1, wherein the means for self-adhering comprises the asphalt layer lower surface having self-adhesive properties.
17. The base roofing membrane according to claim 1, wherein the means for self-adhering comprises the asphalt layer upper surface having self-adhesive properties.
18. The base roofing membrane according to claim 1, wherein the means for self-adhering comprises the layer of asphalt having self-adhesive properties.
19. The base roofing membrane according to claim 1, wherein the means for self-adhering comprises a self-adhering portion of one section of base roofing membrane adhering to one of a self-adhering portion of another section of base roofing membrane or an asphalt and styrene-butadiene-styrene portion of the other section base roofing membrane.
20. The base roofing membrane according to claim 1, wherein the layer of asphalt includes a polymer.
21. The base roofing membrane according to claim 20, wherein the polymer is a styrene-butadiene-styrene copolymer.

22. The base roofing membrane according to claim 1, wherein the means for self-adhering comprises at least a portion of the asphalt layer including a styrene-isoprene-styrene copolymer.
23. In combination:
a base roofing membrane according to claim 1; and
a top membrane adhered to the base roofing membrane.
24. The combination according to claim 23, wherein the top membrane comprises asphalt.
25. The combination according to claim 24, wherein the top membrane asphalt contains a styrene-butadiene-styrene copolymer.
26. The combination according to claim 24, further comprising: an adhesive adhering the top membrane to the base roofing membrane.
27. The combination according to claim 26, wherein the adhesive is a cold adhesive.
28. The combination according to claim 26, wherein the adhesive is a hot adhesive.
29. The combination according to claim 26, wherein the adhesive comprises at least a portion of the upper surface of the base roofing membrane, being exposed styrene-butadiene-styrene asphalt and a lower surface of the top membrane being exposed styrene-butadiene-styrene asphalt, one exposed styrene-butadiene-styrene asphalt surface adhering to the other exposed styrene-butadiene-styrene asphalt surface.

30. The combination according to claim 26, wherein the adhesive is a self-adhesive.
31. The combination according to claim 30, wherein the adhesive comprises asphalt and a styrene-isoprene-styrene copolymer.
32. The combination according to claim 23, wherein the top membrane comprises:
- a layer of asphalt having a length, a width, a first side, a second side, an upper surface and a lower surface; and
 - a longitudinally extending portion of at least one top membrane asphalt layer surface adjacent a top membrane side having self-adhesive properties, the top membrane self-adhesive portion extending only partway across the width of the top membrane asphalt layer.
33. The combination according to claim 32, wherein the self-adhesive portion is on the top membrane asphalt layer upper surface.
34. The combination according to claim 32, wherein the self-adhesive portion is on the top membrane asphalt layer lower surface.
35. The combination according to claim 32, wherein there are two self-adhesive portions, one self-adhesive portion being on the top membrane asphalt layer upper surface adjacent a first side and the other self-adhesive portion being on the top membrane asphalt layer lower surface adjacent a second side.
36. The combination according to claim 32, wherein the top membrane asphalt layer includes a styrene-butadiene-styrene copolymer.

37. The combination according to claim 32, wherein the top membrane self-adhesive portion comprises a portion of the at least one top membrane asphalt layer including a styrene-isoprene-styrene copolymer.
38. The combination according to claim 32, further comprising:
a release film on the top membrane self-adhesive portion.
39. The combination according to claim 32, further comprising:
a protective material adhered to the upper surface of the top membrane asphalt layer, the protective material covering the top membrane asphalt layer upper surface except for any top membrane upper surface self-adhesive portion.
40. The combination according to claim 39, wherein the top membrane protective material is a granular material.
41. The combination according to claim 23, wherein the top membrane is adhered to the base roofing membrane by fusion of the top membrane to the base roofing membrane.
42. The combination according to claim 23, further comprising:
a layer of asphalt primer on the upper surface of the base roofing membrane; and
wherein a lower surface of the top membrane has self-adhesive properties, the self-adhesive top membrane lower surface adhering to the base roofing membrane layer of asphalt primer.
43. The combination according to claim 23, wherein the top membrane comprises:
a layer of asphalt having a length, a width, a first side, a second side, an upper surface and a lower surface; and

the asphalt layer lower surface having self-adhesive properties.

44. The combination according to claim 43, further comprising:
a protective material adhered to the upper surface of the top membrane asphalt layer, the protective material covering the top membrane asphalt layer upper surface except for a longitudinally extending portion adjacent a top membrane side.

45. A base roofing membrane comprising:
a layer of asphalt having a length, a width, a first side, a second side, an upper surface and a lower surface, the layer of asphalt including a styrene-butadiene-styrene copolymer;
a reinforcement within the asphalt layer;
a longitudinally extending portion of the asphalt layer upper surface adjacent the first side having self-adhesive properties, the self-adhesive portion extending only partway across the width of the asphalt layer;
a granular material covering the asphalt layer upper surface except for the self-adhesive portion; and
a release film on the self-adhesive portion.

46. The base roofing membrane according to claim 45, wherein the reinforcement is a non-woven polyester.

47. A roofing membrane comprising:
a base roofing membrane comprising: a layer of asphalt having a length, a width, a first side, a second side, an upper surface and a lower surface, the layer of asphalt including a styrene-butadiene-styrene copolymer; a reinforcement within the asphalt layer; a longitudinally extending portion of the asphalt layer upper surface adjacent the first side having self-adhesive properties, the self-adhesive portion extending only partway across the width of the asphalt layer, the portion of the asphalt layer having self-adhesive proper-

ties comprising asphalt and a styrene-isoprene-styrene copolymer, a layer of asphalt primer on the asphalt layer upper surface; and

a top membrane adhered to the base roofing membrane, the top membrane comprising: a layer of asphalt having a length, a width, a first side, a second side, an upper surface and a lower surface, the top membrane layer of asphalt including a styrene-butadiene-styrene copolymer, the top membrane asphalt layer lower surface having self-adhesive properties; and a protective material adhered to the upper surface of the top membrane asphalt layer, the protective material covering the top membrane asphalt layer upper surface except for a longitudinally extending portion adjacent a top membrane side, the top membrane self-adhesive properties comprising a styrene-isoprene-styrene copolymer.

48. The roofing membrane according to claim 47, wherein the top membrane protective material is a granular material.

49. A roofing membrane comprising:

a layer of asphalt having a length, a width, a first side, a second side, an upper surface and a lower surface;

a reinforcement within the asphalt layer;

a first longitudinally extending portion of the asphalt layer lower surface adjacent the first side having self-adhesive properties, the first self-adhesive portion extending only partway across the width of the asphalt layer;

a second longitudinally extending portion of the asphalt layer upper surface adjacent the second side having self-adhesive properties, the second self-adhesive portion extending only partway across the width of the asphalt layer; and

a layer of granular material covering the asphalt layer upper surface except for the second self-adhesive layer.

50. A method for installing roofing membranes on a roof comprising the steps of:

(a) providing a base roofing membrane comprising: a layer of asphalt having a length, a width, a first side, a second side, an upper surface and a lower surface; a longitudinally extending portion of the asphalt layer upper surface adjacent a side having self-adhesive properties, the self-adhesive portion extending only partway across the width of the asphalt layer; and a release film on the self-adhesive portion;

(b) placing a section of base roofing membrane on the roof;

(c) removing the release film from the upper surface self-adhesive portion;

(d) attaching the section of base roofing membrane to the roof using a plurality of mechanical fasteners inserted through the upper surface self-adhesive portion;

(e) placing an additional section of base roofing membrane on the roof, the lower surface of the additional section of base roofing membrane overlapping, and being adhered to, the upper surface self-adhesive portion of the section of base roofing membrane;

(f) removing the release film from the upper surface of the additional section of base roofing membrane;

(g) attaching the additional section of base roofing membrane to the roof using a plurality of mechanical fasteners inserted through the upper surface self-adhesive portion; and

(h) repeating steps (e) through (g) with each additional section of base roofing membrane overlapping, and being adhered to, the prior additional section of base roofing membrane.

51. The method according to claim 50, further comprising the steps of:

providing a top membrane; and

placing the top membrane on at least a portion of at least one base roofing membrane;

adhering the top membrane to the at least a portion of at least one base roofing membrane.

52. The method according to claim 51, further comprising:

prior to placing the top membrane on at least a portion of at least one base roofing membrane, applying an asphalt primer to the upper surface of the at least one base roofing membrane.

53. The method according to claim 51, wherein the step of adhering comprises placing an adhesive between the top membrane and the at least a portion of at least one base roofing membrane.

54. The method according to claim 51, wherein the step of adhering comprises melting at least one of a lower surface of the top membrane and an upper surface of the at least a portion of at least one base roofing membrane.

55. The method according to claim 51, wherein the step of providing a top membrane comprises providing a top membrane having: a layer of asphalt having a length, a width, a first side, a second side, an upper surface and a lower surface, the asphalt layer lower surface having self-adhesive properties; a protective material covering the upper surface of the top membrane asphalt layer except for a longitudinally extending portion adjacent a top membrane side; and

further comprising the steps of:

(i) placing an additional section of top membrane on at least a portion of at least one base roofing membrane, the lower surface of the additional section of top membrane overlapping, and being adhered to, the self-adhesive portion of the top membrane;

repeating step (i) with the lower surface of each additional section of top membrane overlapping, and being adhered to, the prior additional section of the top membrane.

56. In a roof including a roof membrane, an improvement comprising:
a reinforcement plate having: a central opening therein for receiving a fastener therein to secure the reinforcement plate to the roof; and having a plurality of circumferentially spaced holes therein.
57. The improvement according to claim 56, wherein the reinforcement plate has a plurality of roof membrane compressors extending downward therefrom, each roof membrane compressor compressing a portion of the roof membrane.
58. The improvement according to claim 57, wherein each hole has a roof membrane compressor coincident with a circumferential edge of the hole.
59. The improvement according to claim 58, wherein each roof membrane compressor is located on a clockwise leading edge of a hole.
60. The improvement according to claim 59, wherein each roof membrane compressor has a downwardly extending V-shape.

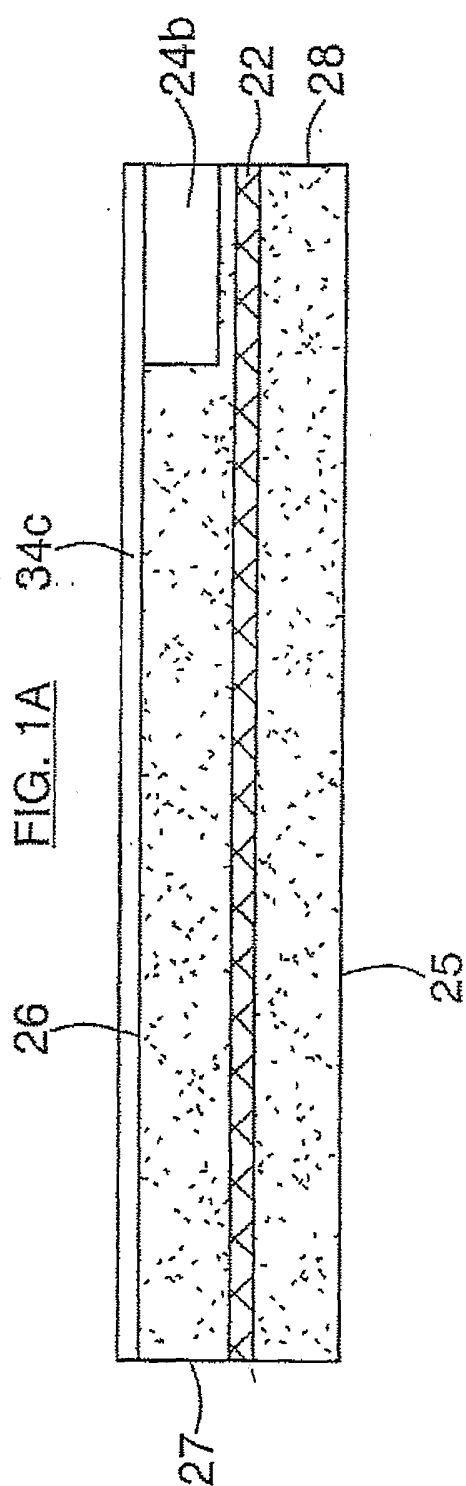
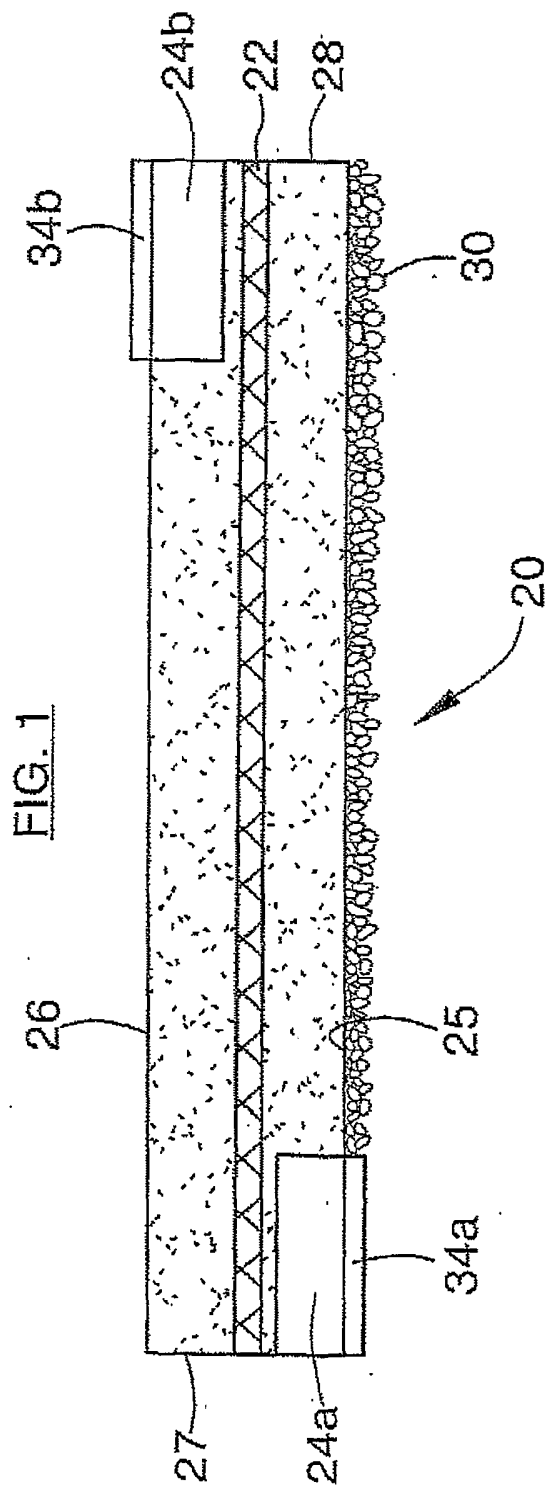

FIG. 1B

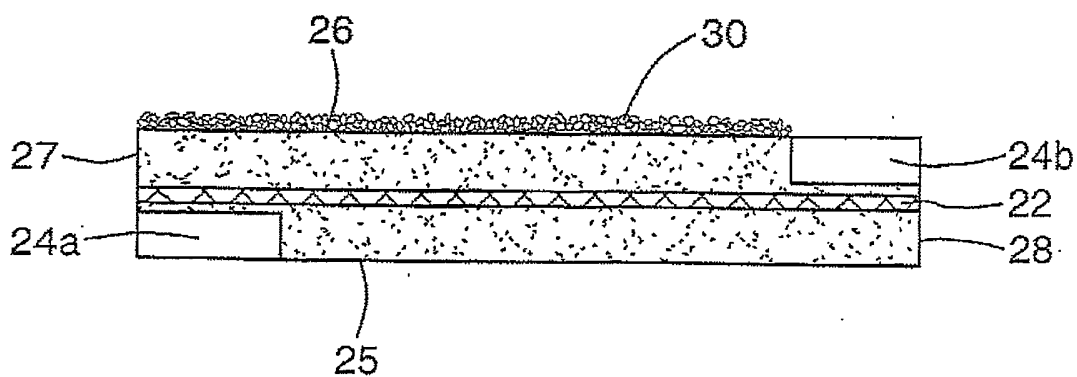

FIG. 1C

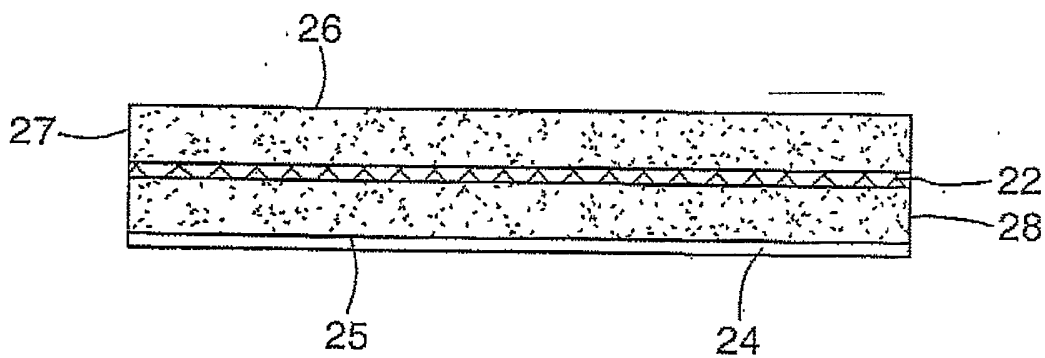
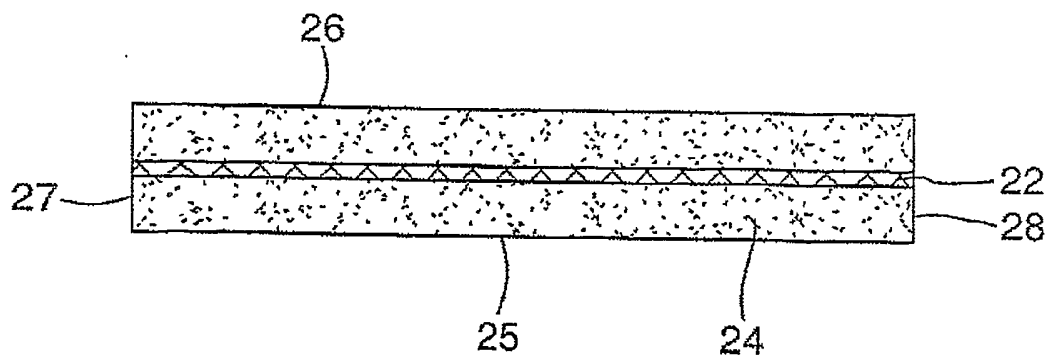
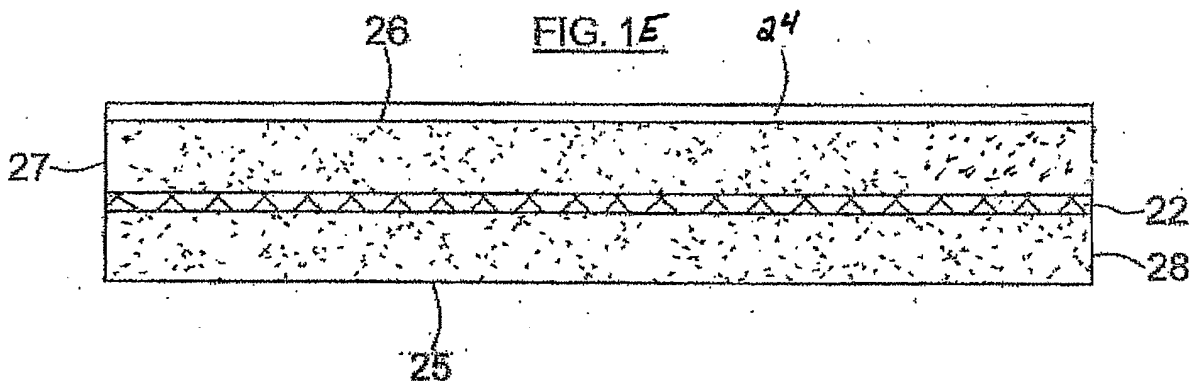

FIG. 1D





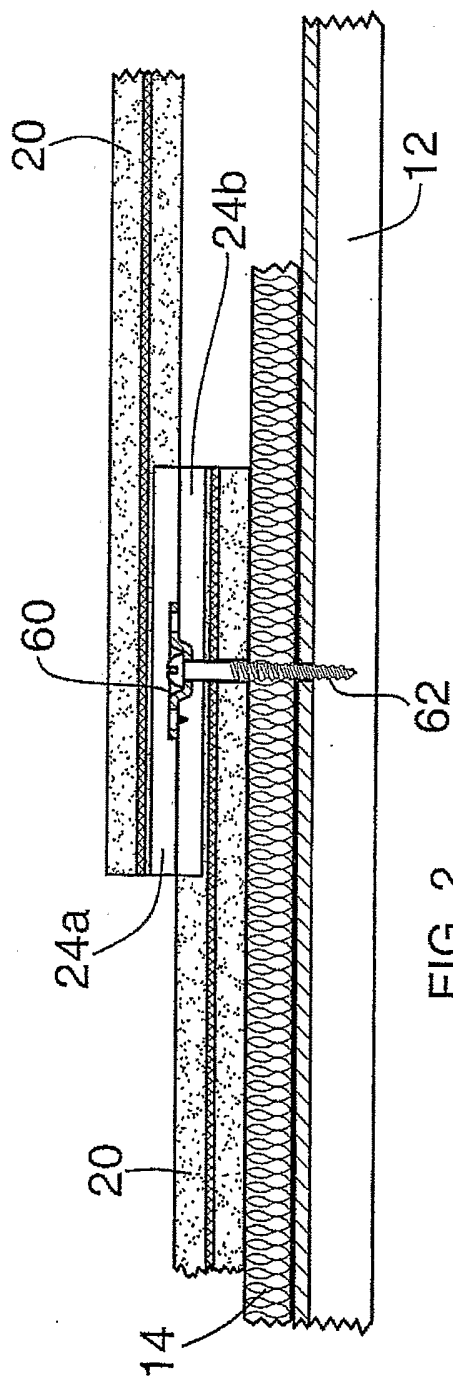

FIG. 2

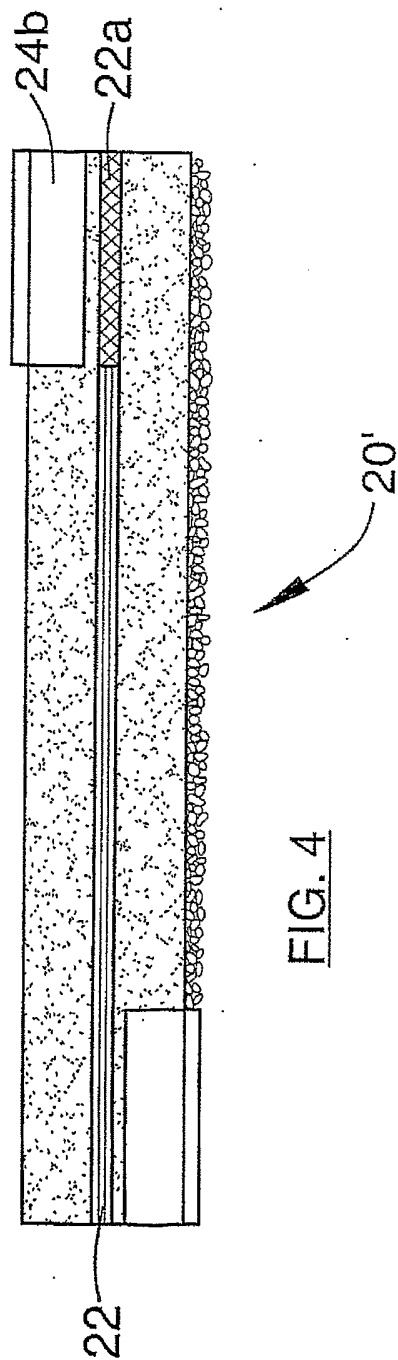

FIG. 4

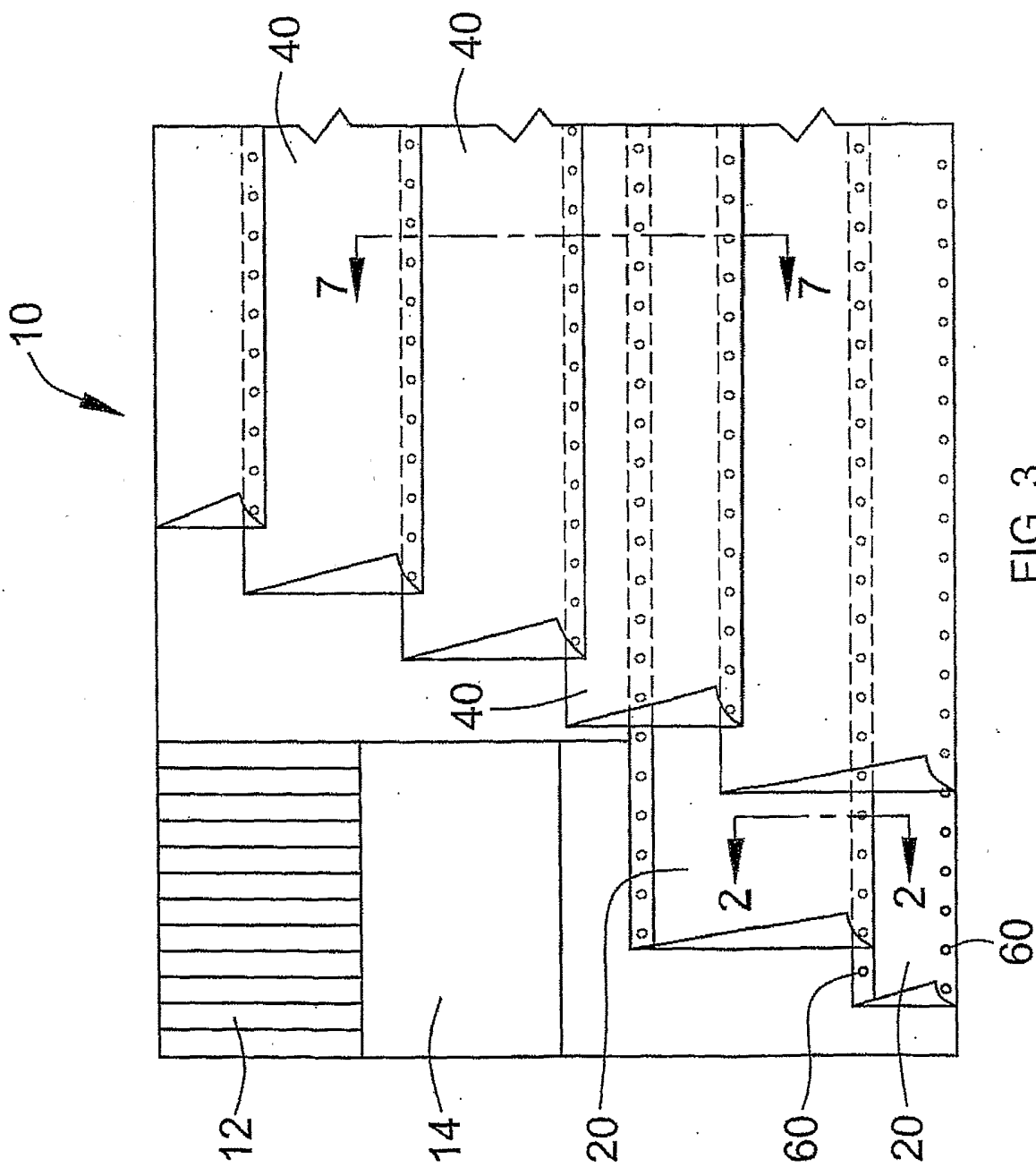

FIG. 3

FIG. 5

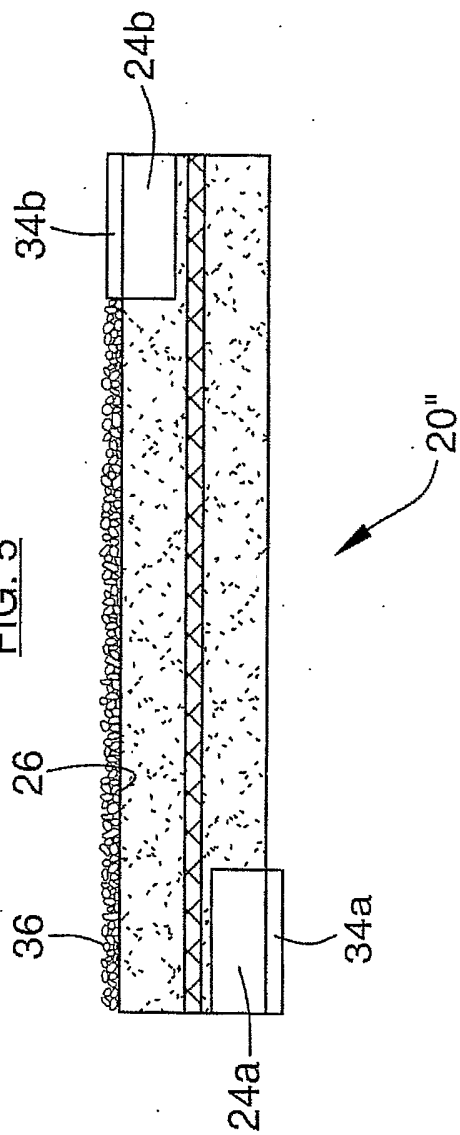

FIG. 6

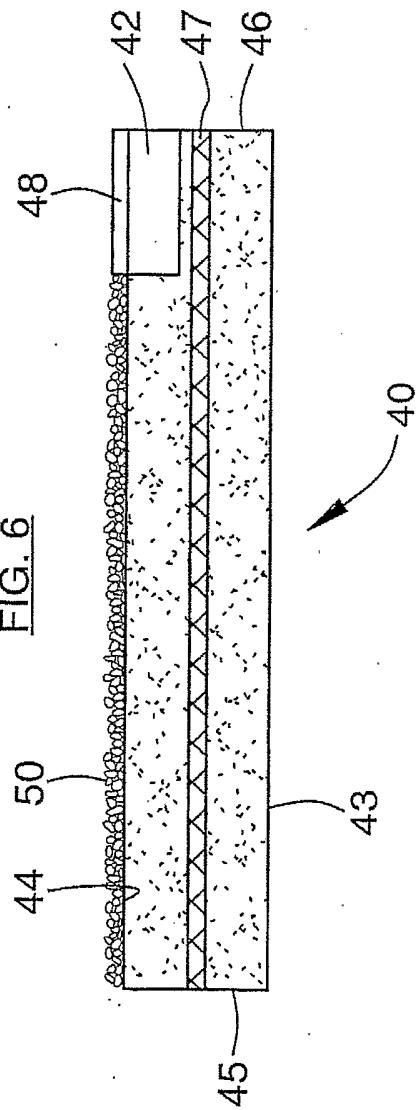

FIG. 6A

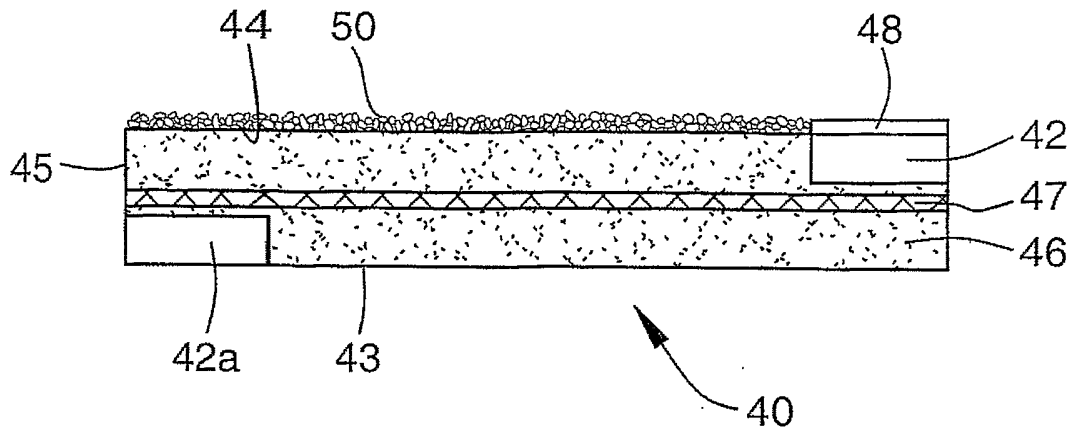

FIG. 6B

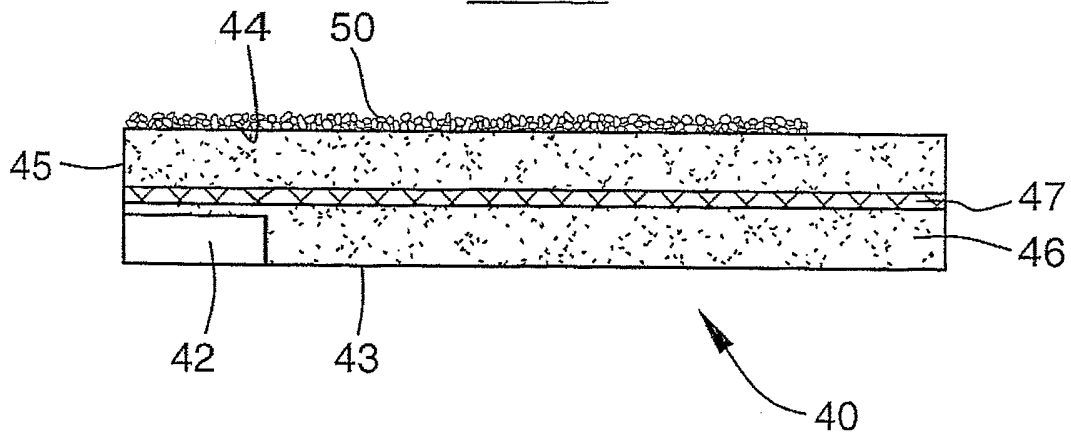
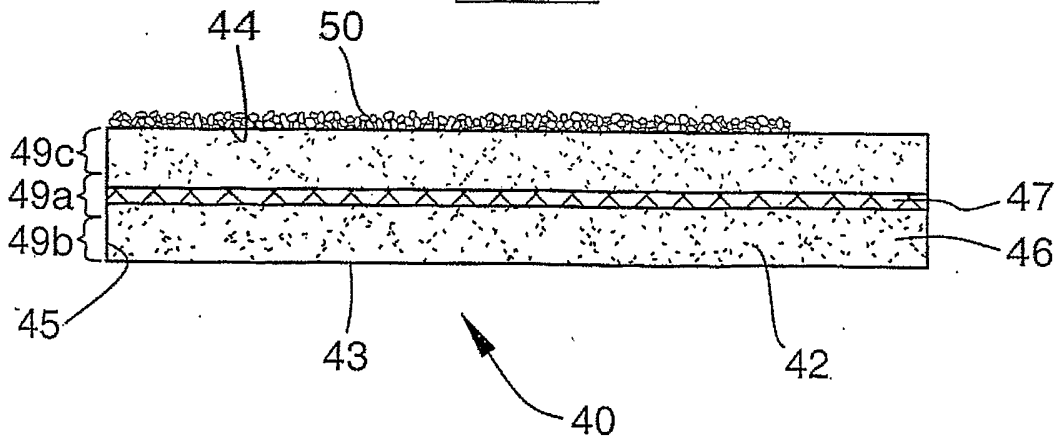

FIG. 6C



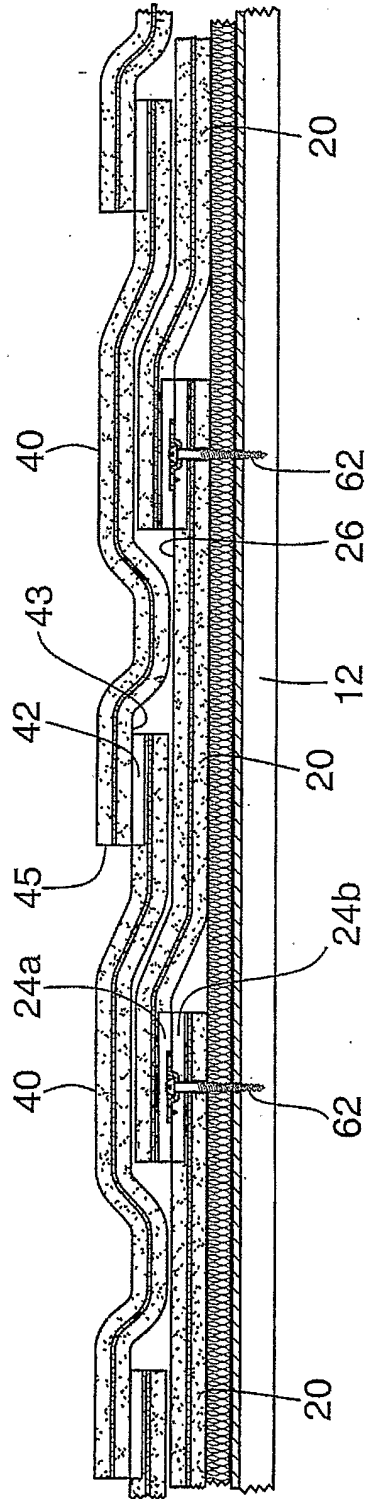

FIG. 7

FIG. 10

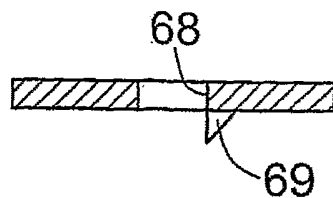

FIG. 9

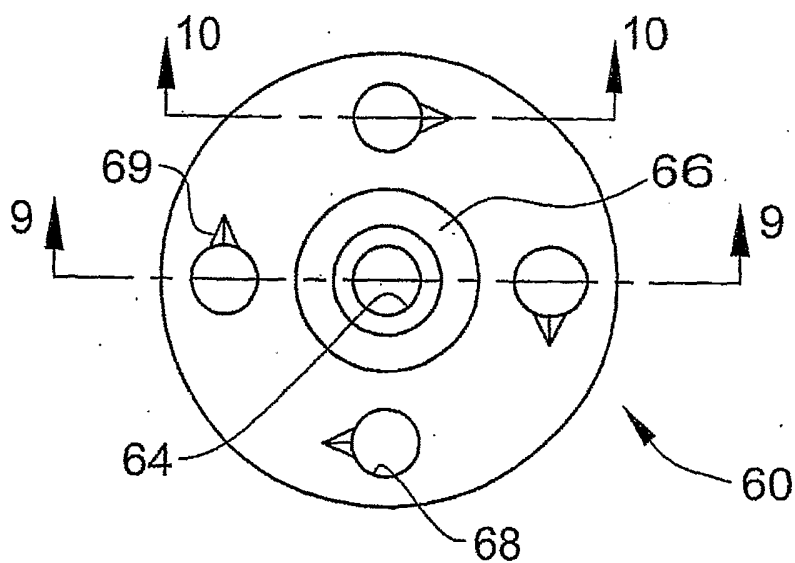
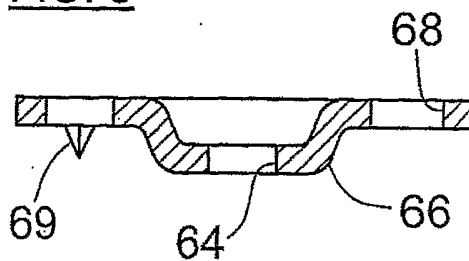

FIG. 8

INTERNATIONAL SEARCH REPORT

International application No.
PCT/US03/05739

A. CLASSIFICATION OF SUBJECT MATTER

IPC(7) : E04B 5/00
US CL : 52/408, 409, 412
According to International Patent Classification (IPC) or to both national classification and IPC

B. FIELDS SEARCHED

Minimum documentation searched (classification system followed by classification symbols)

U.S. : 52/408, 409, 412

Documentation searched other than minimum documentation to the extent that such documents are included in the fields searched

Electronic data base consulted during the international search (name of data base and, where practicable, search terms used)

C. DOCUMENTS CONSIDERED TO BE RELEVANT

Category*	Citation of document, with indication, where appropriate, of the relevant passages	Relevant to claim No.
X	US 5,979,133 A (FUNKHOUSER) 09 November 1999, cols. 1-4.	1, 16-18, 20-25, 41, 43
A, E	US 6,531,200 B2 (ZICKELL et al) 11 March 2003, cols. 1-10.	1-60
A	US 6,360,506 B1 (GRAAE) 26 March 2002, cols. 1-6.	1-60

Further documents are listed in the continuation of Box C. See patent family annex.

* Special categories of cited documents:	"T"	later document published after the international filing date or priority date and not in conflict with the application but cited to understand the principle or theory underlying the invention
"A" document defining the general state of the art which is not considered to be of particular relevance	"X"	document of particular relevance; the claimed invention cannot be considered novel or cannot be considered to involve an inventive step when the document is taken alone
"E" earlier document published on or after the international filing date	"Y"	document of particular relevance; the claimed invention cannot be considered to involve an inventive step when the document is combined with one or more other such documents, such combination being obvious to a person skilled in the art
"L" document which may throw doubts on priority claim(s) or which is cited to establish the publication date of another citation or other special reason (as specified)	"Z"	document member of the same patent family
"O" document referring to an oral disclosure, use, exhibition or other means		
"P" document published prior to the international filing date but later than the priority date claimed		

Date of the actual completion of the international search

11 JUNE 2003

Date of mailing of the international search report

22 AUG 2003

Name and mailing address of the ISA/US
Commissioner of Patents and Trademarks
Box PCT
Washington, D.C. 20231

Facsimile No. (703) 805-3290

Authorized officer

CARL FRIEDMAN

Telephone No. (703) 808-1894