

(12) INTERNATIONAL APPLICATION PUBLISHED UNDER THE PATENT COOPERATION TREATY (PCT)

(19) World Intellectual Property Organization  
International Bureau



(43) International Publication Date  
6 March 2003 (06.03.2003)

PCT

(10) International Publication Number  
WO 03/019031 A1

(51) International Patent Classification<sup>7</sup>: F16D 51/10, 65/08, 65/54

(21) International Application Number: PCT/AU02/01185

(22) International Filing Date: 30 August 2002 (30.08.2002)

(25) Filing Language: English

(26) Publication Language: English

(30) Priority Data:  
PR 7425 31 August 2001 (31.08.2001) AU

(71) Applicant (for all designated States except US): PBR AUSTRALIA PTY LTD [AU/AU]; 264 East Boundary Road, East Bentleigh, Victoria 3165 (AU).

(81) Designated States (national): AE, AG, AL, AM, AT, AU, AZ, BA, BB, BG, BR, BY, BZ, CA, CH, CN, CO, CR, CU, CZ, DE, DK, DM, DZ, EC, EE, ES, FI, GB, GD, GE, GH, GM, HR, HU, ID, IL, IN, IS, JP, KE, KG, KP, KR, KZ, LC, LK, LR, LS, LT, LU, LV, MA, MD, MG, MK, MN, MW, MX, MZ, NO, NZ, OM, PH, PL, PT, RO, RU, SD, SE, SG, SI, SK, SL, TJ, TM, TN, TR, TT, TZ, UA, UG, US, UZ, VC, VN, YU, ZA, ZM, ZW.

(84) Designated States (regional): ARIPO patent (GH, GM, KE, LS, MW, MZ, SD, SL, SZ, TZ, UG, ZM, ZW), Eurasian patent (AM, AZ, BY, KG, KZ, MD, RU, TJ, TM), European patent (AT, BE, BG, CH, CY, CZ, DE, DK, EE, ES, FI, FR, GB, GR, IE, IT, LU, MC, NL, PT, SE, SK, TR), OAPI patent (BF, BJ, CF, CG, CI, CM, GA, GN, GQ, GW, ML, MR, NE, SN, TD, TG).

(72) Inventor; and

(75) Inventor/Applicant (for US only): WANG, Nui [AU/AU]; 12 Tavistock Court, Croydon, Victoria 3136 (AU).

(74) Agent: PHILLIPS ORMONDE & FITZPATRICK; 367 Collins Street, Melbourne, Victoria 3000 (AU).

Published:

— with international search report

For two-letter codes and other abbreviations, refer to the "Guidance Notes on Codes and Abbreviations" appearing at the beginning of each regular issue of the PCT Gazette.

(54) Title: DRUM BRAKE ASSEMBLY

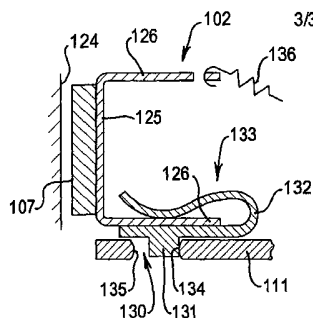

(57) Abstract: A drum brake assembly which includes a rotatable drum having a radially inner drum braking surface and a brake shoe (102) of single piece construction and of generally circular form mounted within the drum and against a backing plate (111). The brake shoe includes friction lining (107) and at least one flange (126) projecting radially inwardly. The brake shoe (102) has positioning means for positioning the brake shoe (102) within the drum in an inoperative condition against lateral movement into engagement with the drum braking surface, to provide for complete clearance between the friction lining (107) and the drum braking surface in the inoperative condition. The positioning means includes engagement means (131, 132) for engagement with abutment means (130). The abutment means (130) includes radially inner and outer abutments (134, 135) and the engagement means (131, 132) is arranged for engagement with the radially inner abutment (134) in the inoperative condition of the assembly to position the friction lining (107) away from the drum braking surface, and with the radially outer abutment (135) when the brake shoe (102) is radially expanded to the operative condition of the assembly. One of the engagement means (131, 132) or the abutment means (130) is formed as a displaceable member (133) which is displaceable radially relative to the brake shoe flange (126) or backing plate (111) for the purpose of maintaining the set running clearance between the friction lining and the drum braking surface upon lining wear. Engagement between the engagement means (131, 132) and the abutment means (130) in the inoperative condition is facilitated by biasing means (136) which biases the brake shoe to return to the inoperative condition. The biasing means may include the shoe undergoing resilient distortion to function as a return spring or it may include bias springs which act on the shoe.



WO 03/019031 A1

DRUM BRAKE ASSEMBLY

The present invention relates to a drum brake assembly and in particular to a drum brake assembly that employs a single piece brake shoe.

5 A drum brake assembly of that kind is disclosed in Applicant's US Patent 5,246,093. That patent discloses a friction lined brake shoe which is of generally circular loop form and which defines two separate and opposed ends. The patent further discloses a drum brake assembly, in which an actuator is disposed between the opposed ends of the brake shoe for increasing the  
10 separation of the ends during a brake application to thereby radially expand the shoe to an operative condition, in which the friction lining engages the drum braking surface. The brake shoe is constructed to resiliently distort during radial expansion and to act as a return spring when the actuating force between the opposed ends is released, to return the shoe to a radially contracted,  
15 inoperative condition, in which the friction lining is spaced from the drum braking surface.

The drum brake assembly disclosed in US 5,246,093 advantageously reduces the number of brake components compared to prior art drum brake assemblies and it simplifies machining or grinding of the friction lining during  
20 brake shoe manufacture. The reduction in components achieved in the drum brake assembly of US 5,246,093 includes a reduction in the number of components employed to secure the brake shoe in place against the backing plate and within the drum, and therefore, compared to prior art drum brake assemblies, the brake shoe of US Patent 5,246,093 is less constrained within  
25 the drum brake assembly. In that assembly, the brake shoe is not fully restrained against "floating" or shifting movement (hereinafter referred to as "lateral movement") across the backing plate when the drum brake assembly is in the inoperative condition. The brake shoe is not loose within the drum, as it is connected at the opposed shoe ends to the actuator and it is restrained against  
30 lifting away from the backing plate by spring clips or a conventional hold down spring, but those connections cannot under all circumstances, prevent the lateral movement referred to above. Thus, the brake shoe can, under certain circumstances, such as during excessive vibration, move laterally over the backing plate and that can cause the brake shoe to become misaligned within

the drum when the drum brake assembly is in an inoperative condition, ie when there is no brake actuating load being applied, so as to reduce the running clearance between the friction lining and the drum braking surface below the set running clearance. In some circumstances, that misalignment may cause the  
5 brake shoe to engage the drum braking surface in the inoperative condition, which is undesirable.

It is an object of the invention to provide an improved brake assembly which employs a single piece brake shoe of the abovedescribed kind, in which the brake shoe is more reliably returned to a position spaced from contact with  
10 the drum braking surface in the inoperative condition.

The present invention provides a drum brake assembly which includes a rotatable drum having a radially inner drum braking surface and a brake shoe of single piece construction and of generally circular form mounted within the drum and against a backing plate. The brake shoe has a radially outer face and  
15 friction lining mounted thereon in facing relationship to the radially inner drum braking surface. The radially outer face of the brake shoe is formed by the radially outer face of an elongate web and the brake shoe includes at least one flange co-extending with the web and projecting radially inwardly from the web. The brake shoe has two separate and opposed ends, and actuating means  
20 positioned between the ends and being operable to enlarge the separation between the ends and to thereby cause radial expansion of the brake shoe from an inoperative brake off condition, in which there is clearance between the friction lining and the radially inner braking surface, to an operative brake on condition, in which the friction lining engages the drum braking surface.  
25 Positioning means is provided for positioning the brake shoe within the drum in the inoperative condition against lateral movement into engagement with the drum braking surface, to provide for complete clearance between the friction lining and the drum braking surface in the inoperative condition. The positioning means includes engagement means which is associated with one of the brake  
30 shoe flange or the backing plate, for engagement with abutment means associated with the other of the brake shoe flange or the backing plate. The abutment means includes radially inner and outer abutments and the engagement means is arranged for engagement with the radially inner abutment in the inoperative condition of the assembly to position the friction

lining away from the drum braking surface, and with the radially outer abutment when the brake shoe is radially expanded from the inoperative condition through the set running clearance between the friction lining and the drum braking surface to the operative condition of the assembly. One of the  
5 engagement means or the abutment means is formed as a displaceable member which is displaceable radially relative to the brake shoe flange or backing plate with which it is associated for the purpose of maintaining the set running clearance between the friction lining and the drum braking surface upon lining wear. Engagement between the engagement means and the abutment  
10 means in the inoperative condition is facilitated by biasing means which biases the brake shoe to return to the inoperative condition. The biasing means may include a function of the brake shoe itself, so that during radial expansion of the brake shoe, the shoe undergoes resilient distortion and therefore functions as a return spring when the shoe is radially expanded to radially contract the shoe  
15 when the actuating load is released. The biasing means may also include bias springs which act on the shoe to return the shoe to a position of engagement between the engagement means and the abutment means. In a preferred arrangement, the shoe functions as a return spring for radial contraction, while biasing springs function to ensure engagement between the engagement  
20 means and the abutment means. Other bias arrangements may also be suitable.

The present invention further provides a brake shoe for use in a drum brake assembly, the brake shoe being of generally circular form and including an elongate web having a radially outer face on which friction lining is mounted,  
25 and a flange co-extending with the web and projecting radially inwardly therefrom. The brake shoe has two separate and opposed ends and in use, an actuator positioned between the ends is operable to increase the separation between the ends to radially expand the shoe. The flange of the brake shoe includes one portion of a positioning means that is provided in a drum brake  
30 assembly in which the brake shoe is employed and that portion is either engagement means or abutment means, the latter of which in use defines radially inner and outer abutments. The other portion is associated with the backing plate of the drum brake assembly and in use, the two portions are cooperable to position the friction lining of the brake shoe for complete

clearance relative to the drum braking surface of the drum brake assembly, in an inoperative condition of the assembly. The cooperation between the engagement means and the abutment means involves engagement by the engagement means with the radially inner abutment in the inoperative condition to position the friction lining away from the drum braking surface, and with the radially outer abutment in the operative condition. One portion of the positioning means is displaceable and preferably that is the portion associated with the flange. That portion may be a displaceable member which is displaceably mounted thereon and radial displacement of the displaceable member relative to the flange is effective to maintain the set running clearance between the friction lining and the drum braking surface as the lining wears.

The present invention further provides abutment means or engagement means of the above kind which is formed as a displaceable member for fixing to either of the flange of a brake shoe according to the invention, or to the backing plate of a drum brake assembly according to the invention. The abutment means or engagement means is formed to be displaceable radially in use.

The positioning means described above can provide engagement between the engagement means and the abutment means at a single position or region, or at two or more positions or regions about the brake shoe. In this respect, the biasing means, including the inherent bias of the brake shoe and a biasing spring arrangement, can be employed to ensure that there is appropriate engagement in the inoperative condition between the engagement means and the abutment means. In the preferred arrangement, the positioning means acts between the brake shoe and the backing plate at two positions, preferably but not necessarily symmetrically about a centre line which extends between the opposed ends of the brake shoe, and preferably in the region of  $30^\circ - 60^\circ$  on either side of the centre line.

The drum brake assembly according to the invention advantageously is operative to position the brake shoe for clearance between the friction lining and the drum braking surface in the inoperative condition. That is, engagement between the engagement means and the abutment means in the inoperative condition positively positions the brake shoe within the drum for friction lining clearance from the drum braking surface and therefore, the set running clearance is achieved in that condition. Moreover, the displaceable nature of

one portion of the positioning means permits compensation for friction lining wear to maintain the running clearance as set.

The set running clearance is the desired clearance between the friction lining and the drum braking surface. It may be measured at a point or points  
5 along the length of the friction lining and the clearance amount may vary through the length. The set running clearance is the optimum clearance which is a balance or trade off between the need to minimise the distance the friction lining travels before it engages the drum braking surface and the need to space the friction lining away from the drum braking surface in the inoperative  
10 condition to ensure that there is no contact between the friction lining and the drum braking surface in that condition. Engagement between the engagement means and the radially outer abutment will occur upon radial expansion of the brake shoe through the set running clearance, but, if the brake assembly is correctly set, not if the radial expansion is less than the set running clearance.  
15 Radial expansion less than the set running clearance may occur for example, when the friction lining is new or unworn and the clearance between the lining and the drum braking surface is less than the set running clearance. It may also occur if the actuating means is set between the opposed ends of the brake shoe such as to resist radial contraction of the brake shoe sufficiently for the set  
20 running clearance to be achieved.

The backing plate referred to herein may alternatively be a dust shield and therefore, the expression "backing plate" is to be understood as including within its scope, a dust shield.

In a preferred arrangement, the displaceable member is formed as a  
25 spring clip which is fitted to either of the backing plate or the flange and which is secured thereto under spring load. The spring clip can be secured to the backing plate or the brake shoe flange in any suitable manner and for example, an opening may be provided in the backing plate to receive the spring clip and to permit the clip to engage opposite sides of the backing plate. In this  
30 example, the spring clip will be formed in a generally U-shape. Alternatively, the backing plate may include a mounting facility for mounting the spring clip and that facility may be formed integrally with the backing plate or can be attached thereto. That facility may include a mounting portion which is suitable for mounting a U-shaped spring clip. In an alternative arrangement, the spring

clip may be of U-shape to engage opposite sides of the flange of the brake shoe. The displaceable member could alternatively take other forms.

For engagement with the abutment means, the engagement means may include a projection. If the engagement means is formed as the displaceable member, the projection preferably is formed integrally with a mounting section of the engagement means, which mounting section is employed to mount the engagement means to either of the flange or the backing plate, such as the spring clip arrangement discussed above. Alternatively, the projection may be punched out of a planar section of the engagement means, or it may be fixed to such a section, such as by welding or threaded connection. Alternatively, if the engagement means is not the displaceable member, the projection could be formed depending directly from the flange or the backing plate, again say by punching or integral connection. Still alternatively, the projection could be an upturned edge of the engagement means, which forms a lip, depending preferably perpendicular to the flange or the backing plate. Such a lip may have only a shallow height or depth sufficient for engagement with the abutment means and may therefore be formed as a step.

In a preferred form, the projection is circular, with its axis disposed substantially perpendicular to the plane of the brake shoe flange or the backing plate. In this form, the projection can be arranged to engage the abutment means at each of two diametrically opposite circumferential positions of its outer circular periphery. That is, the circular projection will have a first point of circumferential engagement in the inoperative condition of the drum brake assembly and a second point of circumferential engagement which is diametrically opposite the first point in the operative condition.

The projection could alternatively be of a different shape, such as the shape known as "fish back", oval, elliptical, square or rectangular, or there may be more than a single projection.

The abutment means can be of any suitable form suitable for abutting cooperation with the engagement means in each of the inoperative and operative conditions. The abutment means could therefore be formed as a circular opening defining an internal circular surface and engagement with the abutment means may be against diametrically opposite sides of that internal surface. Alternatively, the abutment means could be formed as a

circumferential or tangential groove or slot and engagement may be against opposed faces of the groove or slot. In either case, the arrangement preferably should allow circumferential movement of the brake shoe during brake application. Such movement is typically characteristic of single piece brake shoes and resistance to that movement is undesirable.

The abutment means preferably is formed as an opening machined or punched into the backing plate of the drum brake assembly or the flange of the brake shoe, although it may be formed as a component part which is fixed to the backing plate or flange and that part may be formed as the displaceable member, say as a spring clip. Accordingly, it will be appreciated that either of the engagement or the abutment means can be formed as a separate and attachable component and that either of these can form the displaceable member. If each is formed as an attachable component, then preferably only one is formed to be displaceable (in terms of the invention) and the other is fixed. The fixed component may still be formed as a spring clip, but with a loading greater than that of the displaceable member, to maintain its position against displacement. Alternatively, it may include an interlocking arrangement with the flange or the backing plate. Still alternatively, the invention could be achieved by each component being displaceable but that is likely to increase the complexity of the drum brake assembly.

The type of engagement described above is generally of line engagement between the engagement means and the abutment means, but it is equally possible that the engagement be across a broad surface. The engagement surfaces may, for example, be shaped for nesting engagement and could include cooperating surfaces that nest together, such as convex and concave nesting surfaces.

The radially inner and outer abutments of the abutment means are spaced apart a distance which permits the brake shoe to expand and contract radially between the inoperative and the operative conditions through the set running clearance and for there to be engagement between the respective abutments and the engagement means at each of those conditions. As discussed earlier, if the radial expansion is less than the set running clearance, then there will be no engagement between the engagement means and the radially outer abutment in the operative condition. In the arrangements

described above, in which the engagement means includes a projection which can shift between the abutments during brake shoe expansion, the distance between the inner and outer abutments can be the combined total of the maximum radial extent of the projection as measured between the inner and  
5 outer abutments, and the desired or set running clearance between the friction lining and the inner drum braking surface. This separation between the inner and outer abutments permits the brake shoe to expand and contract between the inoperative and operative conditions an amount equal to the set running clearance. For example, the spacing between the inner and outer abutments  
10 when the projection is circular, would be equal to the combined total of the outer diameter of the projection plus the set running clearance.

The above arrangement provides for positive clearance between the friction lining and the drum braking surface, in the inoperative condition of the drum brake assembly by engagement of the engagement means with the  
15 radially inner abutment or abutments. By that engagement, the brake shoe is restrained against lateral movement within the drum in the inoperative condition, so that engagement of the friction lining with the drum braking surface is prevented in the inoperative condition. Additionally, when the friction lining has worn, the engagement means will engage the outer radial abutment  
20 substantially simultaneously with friction lining engagement with the drum braking surface. That engagement causes the displaceable member to be displaced radially outwardly relative to the backing plate or flange to which it is attached as the actuating means continues to expand the brake shoe radially. That displacement repositions the displaceable member so that the radially  
25 inner abutment is displaced radially outwardly. The displaceable member will be displaced an amount relative to the lining wear in the adjacent region of the lining. When the drum brake assembly assumes the inoperative condition, the previous displacement of the displaceable member ensures the correct running clearance is achieved.

30 The present invention is applicable to any form of single piece brake shoe which includes a flange that extends radially inward from a friction lining supporting web and which is mounted on a backing plate or the like. The invention is particularly suitable for the type of brake shoe disclosed in US Patent 5,246,093, which is of channel shaped cross-sectional form, defining a

generally circular web and a pair of parallel flanges depending radially inwardly from side edges thereof. In use, a first of the flanges is disposed against or adjacent the backing plate, while the second flange is spaced axially away from the backing plate. Either of the engagement means or the abutment means can conveniently be attached to or formed on the first flange for cooperation with the other of the engagement or the abutment means formed in or attached to the backing plate preferably at a position which underlies the first flange. That arrangement can be very compact, so as not to interfere with other parts of the drum brake assembly.

10 Installation of the positioning means preferably occurs before the drum brake assembly is assembled. In the preferred method of installation, the displaceable member is fitted to the flange of a single piece brake shoe secured in an installation jig, which simulates a drum brake assembly. An actuator disposed between the opposed ends of the brake shoe is actuated to radially expand the brake shoe to engage the friction lining against a simulated drum braking surface. In the simulated operative drum brake condition, the engagement means will engage the abutment means at the outer radial abutment and the displaceable member will be displaced, if required, to a set position. With the displaceable member thus set, the brake shoe can be assembled in the drum brake assembly. Advantageously, the accuracy with which the displaceable member is fitted in the jig to the brake shoe is not critical and this is important, given that the jig simulation may not be a precise simulation of each drum brake assembly. If the position of the displaceable member as set in the jig causes the local running clearance in the region of the displacement member in the actual drum brake assembly to be too great, then the engagement means will engage the outer radial abutment of the abutment means ahead of the friction lining engaging the drum braking surface. However, that will be corrected on first use of the drum brake assembly by the displaceable member being shifted radially outwardly during the first drum brake application. Conversely, any inaccuracy which results in the running clearance being too small can be corrected during drum brake assembly by the installation personnel, although it is preferred in the method of the invention, to set the displaceable member to always achieve a slightly larger than required running

clearance, and rely on correction of that upon the first application of the drum brake assembly.

The attached drawings show example embodiments of the invention of the foregoing kind. The particularity of those drawings and the associated  
5 description does not supersede the generality of the preceding broad description of the invention.

Figures 1 and 2 show prior art drum brake assemblies.

Figure 3 is a cross-sectional view of one embodiment of the invention taken through III-III of Figure 2.

10 Figures 4 and 5 are alternative cross-sectional views taken through III-III of Figure 2 of second and third embodiments of the invention.

Figures 1 and 2 show prior art arrangements depicted in applicant's US Patent 5,246,093. Briefly, these figures show a parking brake assembly which includes a brake shoe 2 and a backing plate 11. The brake shoe 2 has a body  
15 5 which is of U-shaped channel section defined by a circular web 25 and a pair of parallel flanges 26 extending radially inward from side edges of the web 25. The brake shoe 2 has a pair of friction linings 6 and 7 adhered to the radially outer face 8 of the web 25. The brake shoe defines opposed ends 28 and Figure 1 shows an actuating arrangement 9 which is operable to enlarge the  
20 separation between the ends 28 and thereby to radially expand the brake shoe 2. Attached to the backing plate 11 is a hold down spring 45 and Figure 2 shows that spring extending over the edge of one of the flanges 26. The combination of the hold down spring 45 engaging over the flange 26 and the cooperation between the shoe ends 28 in the grooves 22 of the actuating  
25 arrangement 9, prevents the brake shoe 2 from lifting away from the backing plate 11.

The brake shoe 2 is constructed to be resiliently deformable when the actuating arrangement 9 applies an actuating load to radially expand the shoe. Accordingly, upon release of the actuating load, the shoe contracts radially.  
30 The construction of the brake shoe 2 is such that the shoe ends 28 remain firmly in contact with the groove 22 at all times and particularly in the inoperative condition of the drum brake assembly. The construction of the brake shoe 2 and the operation of the drum brake assembly are described fully in US Patent

5,246,093. The specification of that patent is therefore incorporated herein by cross-reference, for reference if further detail is required.

Figure 3 illustrates one form of the invention and is a cross-sectional view through III-III of prior art Figure 2. Like parts are therefore given the same reference numeral, plus 100. Accordingly, Figure 3 shows a channel section  
5 brake shoe 102 having a web 125 and a pair of flanges 126 depending therefrom radially inwardly. A friction lining 107 is fixed to the radially outer surface of the web 125 and is disposed in facing relationship with a drum braking surface 124. The brake shoe 102 is located adjacent the backing plate  
10 111, which includes abutment means in the form of an opening 130.

Disposed within the opening 130 is a projection 131, which projects from a body 132 which is formed as a spring clip about the flange 126 as shown. The projection 131 and the body 132 constitute engagement means hereinafter referred to as an engagement member 133. The spring clip form of the body  
15 132 is constructed to securely fasten the body to the flange 126 adjacent the backing plate 111. The engagement means and the abutment means constitutes the positioning means of the invention.

The projection 131 is substantially circular in plan view, while the opening 130 is of any suitable shape, such as circular or elongate. Figure 3a is a plan  
20 view of a part of the backing plate 111 which shows the opening 130 as having an elongate shape. The important characteristic of the opening 130, is that it defines a pair of radially spaced abutments 134 and 135 and that the projection 131 is movable into engagement with the respective abutments 134 and 135 at points of brake shoe radial contraction and expansion. In the  
25 position shown in Figure 3, the drum brake assembly is in the inoperative condition, in that the projection 131 is engaged against the radially inner abutment 134 and as shown, the friction lining 107 is spaced from the drum braking surface 124 at the set running clearance. The elongate shape of the  
30 opening 130 also advantageously accommodates circumferential movement of the projection 131 therewithin, which, as discussed earlier, typically occurs during brake application of a single piece brake shoe.

The arrangement shown in Figure 3 preferably is also provided symmetrically on the other side of the centreline shown in Figure 2, which extends between the opposed ends 28 of the brake shoe 2. By providing the

two arrangements on either side of the centre line, preferably symmetrically, the brake shoe 102 can be positively positioned in the inoperative condition with clearance between the friction lining and the drum braking surface.

The brake shoe 102 will return to engagement with the radially inner  
5 abutment 134 either under its own resilience, or in combination with further  
biasing means. The further biasing means may take any suitable form, such as  
a coil spring or springs that extend in contact between the brake shoe 102 and  
the backing plate 111. The further biasing means may include two coil springs  
10 for example, connected to the brake shoe at or in the region of each of the  
engagement members. The biasing means alternatively may include more than  
two springs, disposed in any suitable manner about the brake shoe and in  
connection with the backing plate. The attachment point of the spring or springs  
to the brake shoe 102 may be at the flange 126 remote from the backing plate  
111, and in that arrangement the or each spring would exert a force on the  
15 brake shoe towards the backing plate. Thus, the hold down spring 45 of Figure  
2 may not be required. A single spring would preferably be connected to the  
brake shoe along the centreline of Figure 2 particularly in the event that the  
positioning means is provided symmetrically on either side of the centre line.  
Alternatively, a pair of springs may extend from the flange 126 remote from the  
20 backing plate 111 in the region of the engagement members 133 and one of the  
pair of springs 136 of this arrangement is shown in Figure 3. Whatever biasing  
means is employed, the return bias strength must be lower than that which  
would displace the engagement member 133 on the flange 126.

The arrangement of Figure 3 advantageously permits compensation for  
25 friction lining wear in the friction lining 107 in the following manner. The radial  
extent of the opening 130 is sized to permit radial movement of the projection  
131 radially outwardly away from the abutment 134 into engagement with the  
abutment 135. The movement between abutments is about equal to the  
desired running clearance between the friction lining 107 and the drum braking  
30 surface 124, so that the projection 131 engages the outer abutment 135 at the  
same time as the friction lining engages the drum braking surface 124 in an  
unworn friction lining. However, the engagement of the projection 131 with the  
abutment 135 is not intended to resist proper engagement between the friction  
lining 107 and the drum braking surface 124 when the friction lining has worn.

Rather, that engagement operates to shift the position of the engagement member 133 relative to the flange 126, and thereby provide compensation as the friction lining 107 wears.

Wear compensation is provided as follows. The brake shoe 102 is expanded radially to engage the friction lining 107 with the drum braking surface 124. When that engagement occurs, the projection 131 engages the outer abutment 135. When the friction lining 107 wears, the projection 131 will engage the abutment 135 in advance of the friction lining 107 engaging the drum braking surface 124. The force with which the body 132 is fixed against the flange 126 is not sufficient to prevent further radial expansion of the brake shoe 102 toward the drum braking surface 124, but because the abutment 135 is fixed, the engagement member 133 will be forcibly shifted relative to the flange 126 radially inwardly. When the brake actuating load is released and the brake shoe 102 contracts radially, then the projection 131 will shift from engagement with the outer abutment 135 and return to engagement with the inner abutment 134. However, because of the radial shift of the engagement member 133, and because the distance the projection 131 can travel between the outer and inner abutments 134 and 135 is fixed, the brake shoe 102 can contract radially a lesser amount than before friction lining wear and thus the web 125 is positioned closer to the drum braking surface 124. That closer positioning compensates for friction lining wear by maintaining the radially outer surface of the friction lining at a set distance from the drum braking surface 124 at all times.

An alternative arrangement that achieves the same functional characteristics as the Figure 3 embodiment, but by a different constructional arrangement, is shown in Figure 4. This arrangement can be positioned at the same positions as the Figure 3 arrangement described in relation to Figure 2. Like Figure 3, the Figure 4 arrangement is a cross-sectional view taken through the section III-III of Figure 2.

In Figure 4, the like parts from Figure 3 have the same reference numeral, plus 100. Accordingly, in Figure 4, a brake shoe 202 is shown having a central web 225 and a pair of radially inwardly extending flanges 226 depending from side edges thereof. The brake shoe 202 has a friction lining 207 attached to the radially outer surface of the web 225 in facing relationship

with the drum braking surface 224. The brake shoe 202 is mounted adjacent a backing plate 211 and extending from the backing plate is a mounting facility 240, which comprises an axial extension 241 and a radial extension 242 depending therefrom. Mounted to the mounting facility 240 is an engagement member 233, which has a projection 231 and a body 232 formed as spring clip. The flange 226 adjacent the radial extension 242 includes an opening 230 for receipt of the projection 231 and the opening 230 defines opposed inner and outer abutments 234 and 235. The operation of the Figure 4 arrangement is similar to the Figure 3 arrangement, in that the projection 231 is engagable with the inner and outer abutments 234 and 235 in the operative and inoperative drum brake assembly conditions respectively. It is to be noted however, that this is an opposite sequence of engagement compared to the Figure 3 arrangement. Likewise, the engagement member 233 is displaceable to compensate for friction lining wear, but in the Figure 4 arrangement, the displacement is on the radial extension 242 of the mounting facility 240.

As shown in Figure 4, the mounting facility 240 is formed integrally with the backing plate 211. In an alternative arrangement, the mounting facility may be connected to the backing plate by any suitable means such as by welding bolting or riveting, or by threaded engagement or friction fit. The radial extension 242 could, for installation convenience, be of circular disc form and be connected centrally in the axial extension 241, so that there is no orientation difficulty in installing the mounting facility as a separate component to the backing plate.

The spring load of the engagement members 133 and 233 against the brake shoe flange 126 (Figure 3) or the radial member 242 (Figure 4) must be sufficient to restrain the respective engagement members against displacement under the load experienced in the inoperative condition, but to allow displacement in the operative condition to compensate for friction lining wear. The load experienced by the displacement members in the inoperative condition includes the resilient return load of the single piece brake shoe and any biasing load that may also be applied. The load may also include dynamic loads resulting from vibration. The loads typically will be substantially less than the actuating load to initiate engagement between the friction lining and the drum

braking surface and thus, the required load for mounting the engagement member will not interfere with brake application.

A further alternative arrangement is illustrated in Figure 5. Again, all like parts with Figure 3 have the same reference numeral, plus 200. It will be readily apparent as to those like features, and therefore detailed discussion will relate only to areas of difference. In the Figure 5 embodiment, an opening 350 is formed in the backing plate 311 for receipt of the engagement member 333. The engagement member 333 is formed as a spring clip to engage against opposite sides of the backing plate 311. The arrangement operates similar to the previous Figure 3 and 4 arrangements, in that the engagement member locates the brake shoe 302 in the inoperative drum brake condition and is displaceable in the operative condition relative to the backing plate 311 to compensate for friction lining wear.

The arrangements illustrated in Figures 3 to 5 all show the engagement member as a spring clip, but it is to be appreciated that the spring clip form is just an example of the type of form the engagement member could take and various other forms are within the scope of the present invention.

The invention described herein is susceptible to variations, modifications and/or additions other than those specifically described and it is to be understood that the invention includes all such variations, modifications and/or additions which fall within the scope of the following claims.

CLAIMS

1. A drum brake assembly which includes a rotatable drum having a radially inner drum braking surface and a brake shoe of single piece construction and of generally circular loop form mounted within the drum and against a backing plate, said brake shoe having a radially outer face and friction lining mounted thereon in facing relationship to said radially inner drum braking surface, said brake shoe having two separate and opposed ends, and actuating means positioned between said ends and being operable to enlarge the separation between said ends and to thereby cause radial expansion of said brake shoe from an inoperative brake off condition, in which there is clearance between said friction lining and said drum braking surface, to an operative brake on condition, in which said friction lining engages said drum braking surface, said radially outer face of said brake shoe being formed by the radially outer face of an elongate web and said brake shoe including at least one flange co-extending with said web and projecting radially inwardly from said web, positioning means being provided for positioning said brake shoe within said drum in the inoperative condition against lateral movement into engagement with said drum braking surface, to provide for complete clearance between said friction lining and said drum braking surface in the inoperative condition, said positioning means including engagement means which is associated with one of said brake shoe flange and said backing plate, for engagement with abutment means associated with the other of said brake shoe flange and said backing plate, said abutment means including radially inner and outer abutments and said engagement means being arranged for engagement with said radially inner abutment in the inoperative condition of said assembly to position said friction lining away from said drum braking surface, and with said radially outer abutment when said brake shoe is radially expanded from the inoperative condition through the set running clearance between said friction lining and said drum braking surface to the operative condition of said assembly, one of said engagement means and said abutment means being formed as a displaceable member which is displaceable radially relative to said brake shoe flange or said backing plate with which it is associated for the purpose of maintaining the set running clearance between said friction lining and said drum braking surface

upon lining wear, wherein engagement between said engagement means and said abutment means in the inoperative condition is facilitated by biasing means which biases said brake shoe to return to the inoperative condition.

5 2. A drum brake assembly according to claim 1, said biasing means being comprised at least in part, by the construction of said brake shoe, which is constructed to resiliently distort during radial expansion under brake actuation and to radially contract under brake release.

10 3. A drum brake assembly according to claim 2, said biasing means further including a biasing spring.

4. A drum brake assembly according to any one of claims 1 to 3, said positioning means providing for engagement between said engagement means  
15 and said abutment means at two or more positions or regions about said brake shoe.

5. A drum brake assembly according to claim 4, said two positions being spaced symmetrically about a centre-line of said brake shoe which extends  
20 between said opposed ends of said brake shoe and through the centre of said brake shoe.

6. A drum brake assembly according to claim 5, said two positions being spaced apart in the region of 30°-60° on either side of said centre-line.

25 7. A drum brake assembly according to any one of claims 1 to 6, said displaceable member being formed as a spring clip which is fitted to one of said backing plate and said brake shoe flange and is secured thereto under spring load.

30 8. A drum brake assembly according to claim 7, said backing plate including an opening for receipt of said spring clip, so that said spring clip can engage opposite sides of said backing plate.

9. A drum brake assembly according to claim 7, said backing plate including a mounting facilitating extending therefrom for mounting said spring clip.
- 5 10. A drum brake assembly according to claim 7, said spring clip being arranged to engage opposite sides of said brake shoe flange.
11. A drum brake assembly according to any one of claims 1 to 10, said engagement means including a projection for abutting engagement with said  
10 abutment means.
12. A drum brake assembly according to claim 11, said engagement means being formed as said displaceable member and said projection being formed as part of a mounting section of said displaceable member which facilitates  
15 mounting of said displaceable member to one of said backing plate and said brake shoe flange.
13. A drum brake assembly according to claim 11, said projection being formed to project from one of said backing plate and said brake shoe flange.  
20
14. A drum brake assembly according to any one of claims 11 to 13, said projection being circular and the axis thereof being disposed substantially perpendicular to the plane of said brake shoe flange or said backing plate with which it is associated, and being arranged for engagement with said abutment  
25 means at each of two diametrically opposite circumferential positions of its outer circular periphery.
15. A drum brake assembly according to any one of claims 11 to 13, said projection being shaped as "fish back", oval, elliptical, square or rectangular.  
30
16. A drum brake assembly according to any one of claims 1 to 15, said abutment means being formed as a circular opening defining an internal circular surface periphery and engagement with said abutment means by said

*engagement means is against diametrically opposite positions of said internal surface.*

5 17. A drum brake assembly according to any one of claims 1 to 15, said abutment means being formed as a circumferential or tangential groove opening or slot opening which defines opposed faces for engagement by said engagement means, and which permits circumferential movement of said brake shoe.

10 18. A drum brake assembly according to claim 16 or 17, said opening being formed in said flange or said backing plate.

15 19. A drum brake assembly according to claim 16 or 17, said opening being formed in a separate component part which is fixed to said flange or said backing plate.

20 20. A drum brake assembly according to claim 19, said component part being fixed to said flange or said backing plate as said displaceable member.

20 21. A drum brake assembly according to any one of claims 1 to 20, said brake shoe including a pair of generally parallel flanges depending radially inwards from opposite side edges of said elongate web, wherein in use, a first of said pair of parallel flanges is disposed against or adjacent said backing plate and the second of said pair of parallel flanges is spaced axially away from said  
25 backing plate, one of said engagement means and said abutment means being associated with said first of said pair of parallel flanges, and the other of said engagement means and said abutment means being associated with said backing plate.

**FIG 1**  
(PRIOR ART)

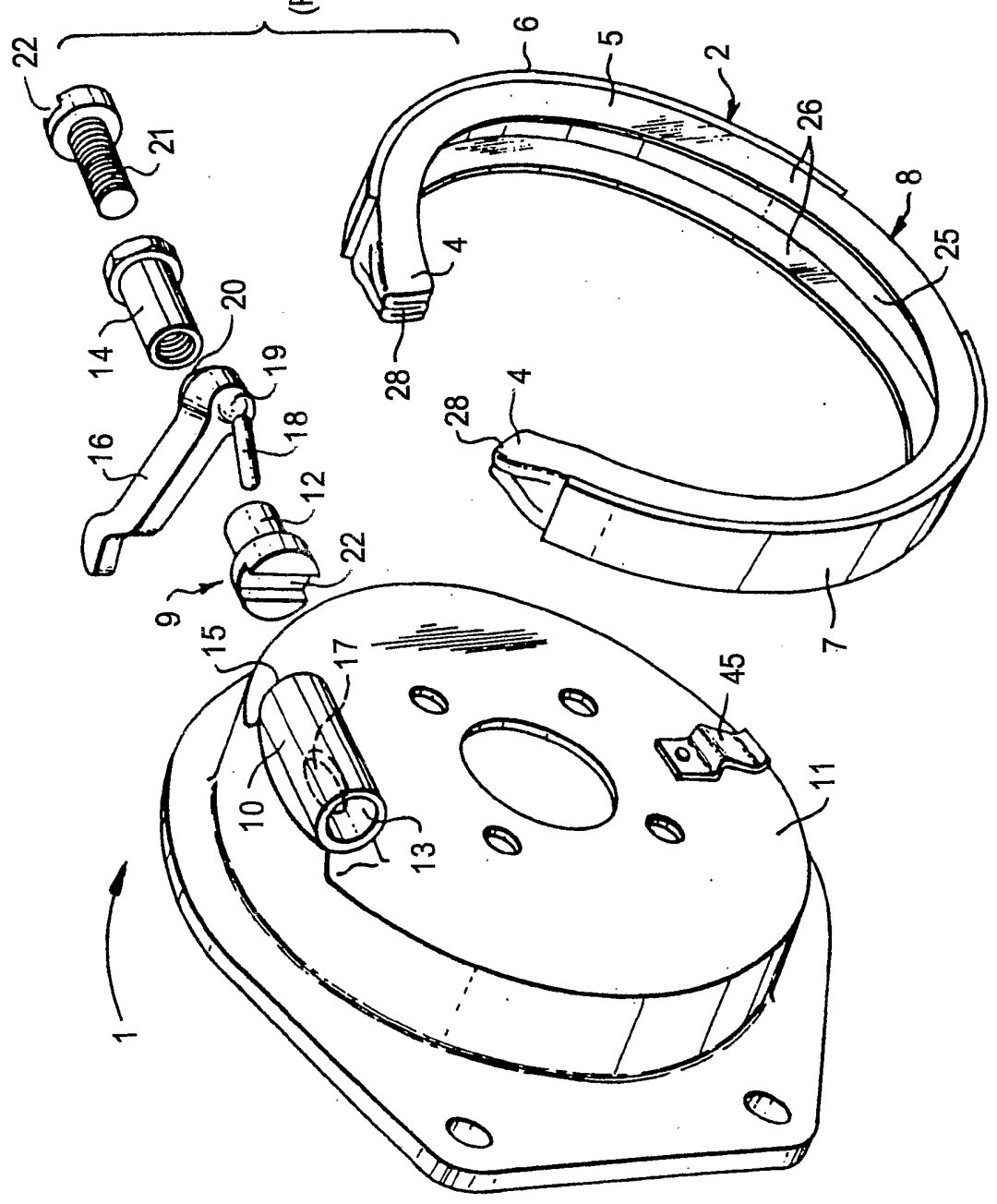

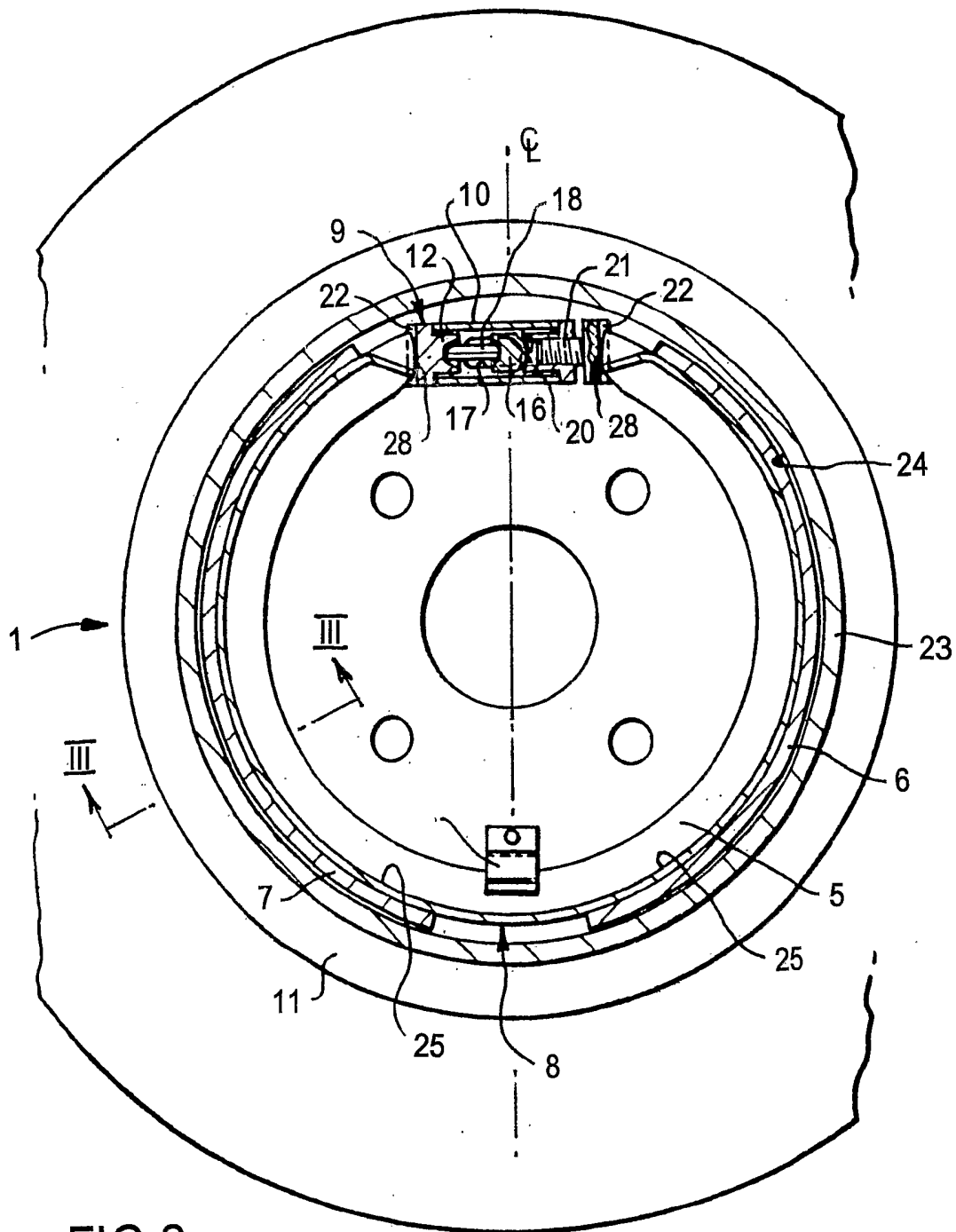

FIG 2  
(PRIOR ART)

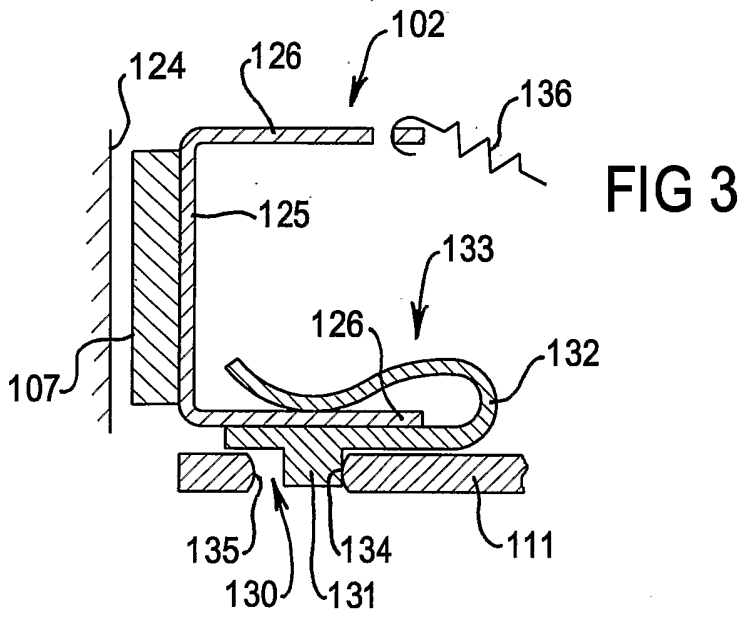

FIG 3

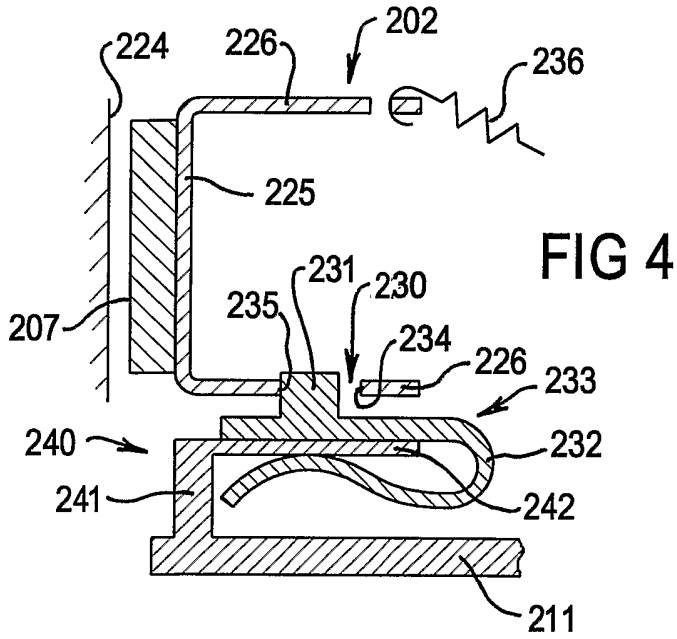

FIG 4

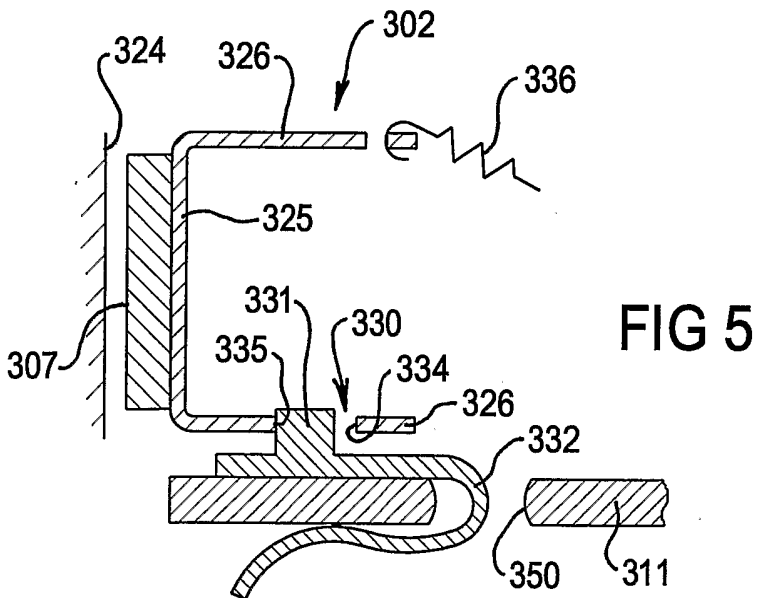

FIG 5

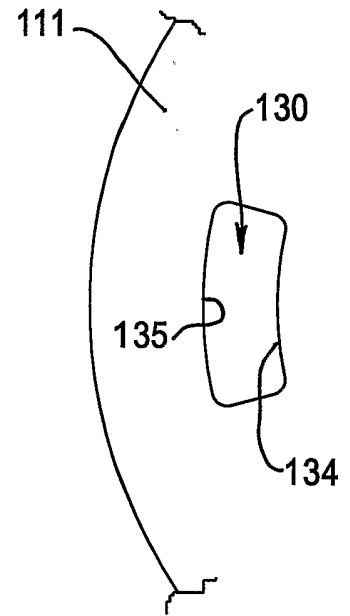

FIG 3A

## INTERNATIONAL SEARCH REPORT

International application No.

PCT/AU02/01185

<b>A. CLASSIFICATION OF SUBJECT MATTER</b>		
Int. Cl. <sup>7</sup> : F16D 51/10, 65/08, 65/54		
According to International Patent Classification (IPC) or to both national classification and IPC		
<b>B. FIELDS SEARCHED</b>		
Minimum documentation searched (classification system followed by classification symbols)		
Documentation searched other than minimum documentation to the extent that such documents are included in the fields searched		
Electronic data base consulted during the international search (name of data base and, where practicable, search terms used) DWPI: IPC F16D 51/10, 65/08, 65/52, 65/54 with shoe, clearance, gap or spacing.		
<b>C. DOCUMENTS CONSIDERED TO BE RELEVANT</b>		
Category*	Citation of document, with indication, where appropriate, of the relevant passages	Relevant to claim No.
A	US 5246093 A (WANG) 21 September 1993 Whole document	
A	US 2273223 A (SAWTELLE) 17 February 1942 Whole document	
A	US 2596379 A (DODGE) 13 May 1952 Whole document	
<input type="checkbox"/> Further documents are listed in the continuation of Box C <input checked="" type="checkbox"/> See patent family annex		
* "A"	Special categories of cited documents: document defining the general state of the art which is not considered to be of particular relevance	"T" later document published after the international filing date or priority date and not in conflict with the application but cited to understand the principle or theory underlying the invention
"E"	earlier application or patent but published on or after the international filing date	"X" document of particular relevance; the claimed invention cannot be considered novel or cannot be considered to involve an inventive step when the document is taken alone
"L"	document which may throw doubts on priority claim(s) or which is cited to establish the publication date of another citation or other special reason (as specified)	"Y" document of particular relevance; the claimed invention cannot be considered to involve an inventive step when the document is combined with one or more other such documents, such combination being obvious to a person skilled in the art
"O"	document referring to an oral disclosure, use, exhibition or other means	"&" document member of the same patent family
"P"	document published prior to the international filing date but later than the priority date claimed	
Date of the actual completion of the international search 24 September 2002		Date of mailing of the international search report 30 SEP 2002
Name and mailing address of the ISA/AU AUSTRALIAN PATENT OFFICE PO BOX 200, WODEN ACT 2606, AUSTRALIA E-mail address: pct@ipaustralia.gov.au Facsimile No. (02) 6285 3929		Authorized officer  <b>KURT TOBLER</b> Telephone No : (02) 6283 2469

# INTERNATIONAL SEARCH REPORT

Information on patent family members

International application No.

**PCT/AU02/01185**

This Annex lists the known "A" publication level patent family members relating to the patent documents cited in the above-mentioned international search report. The Australian Patent Office is in no way liable for these particulars which are merely given for the purpose of information.

Patent Document Cited in Search Report		Patent Family Member					
US	5246093	AU	641146 B (52544/90)	CA	2014413 A	JP	3014925 A
		EP	1069333 A	EP	892190 A	EP	392829 A
END OF ANNEX							