



US00D407348S

United States Patent [19]
Riley

[11] **Patent Number: Des. 407,348**
[45] **Date of Patent: **Mar. 30, 1999**

- [54] **THREE-WHEELED VEHICLE**
- [75] Inventor: **Robert Q. Riley**, Scottsdale, Ariz.
- [73] Assignee: **Lawrence K. Edwards**, Fairfax, Va.
- [**] Term: **14 Years**
- [21] Appl. No.: **84,620**
- [22] Filed: **Mar. 6, 1998**
- [51] **LOC (6) Cl.** **12-08**
- [52] **U.S. Cl.** **D12/85**
- [58] **Field of Search** D12/85, 90-92;
180/210, 215, 217

Chris Rees, *Three-Wheelers: From Morgan to Messerschmitt, Benz to Bond and beyond . . .*, 1995, pp. 74, 135, 136, 138, and 150.

Primary Examiner—Melody N. Brown
Attorney, Agent, or Firm—Senniger, Powers, Leavitt & Roedel

[57] **CLAIM**

The ornamental design for a three-wheeled vehicle, as shown and described.

DESCRIPTION

FIG. 1 is a right side elevational view of a three-wheeled vehicle;

FIG. 2 is a top plan view thereof;

FIG. 3 is a front elevational view thereof;

FIG. 4 is a rear elevational view thereof; and,

FIG. 5 is a front elevational view thereof of the vehicle leaning to one side as when negotiating a curve.

- [56] **References Cited**
- U.S. PATENT DOCUMENTS**
- D. 203,665 2/1966 Cherry et al. D12/85
- D. 268,402 3/1983 Riley et al. D12/85
- D. 274,398 6/1984 Heyes D12/85
- D. 274,995 8/1984 Richardo et al. D12/85
- D. 283,113 3/1986 Stolley D12/85
- D. 329,212 9/1992 Murkett et al. D12/91

OTHER PUBLICATIONS

Robert Q. Riley, *Alternative Cars in the 21st Century: A New Personal Transportation Paradigm*, 1994, pp. 282-283 and 366-367.

1 Claim, 2 Drawing Sheets

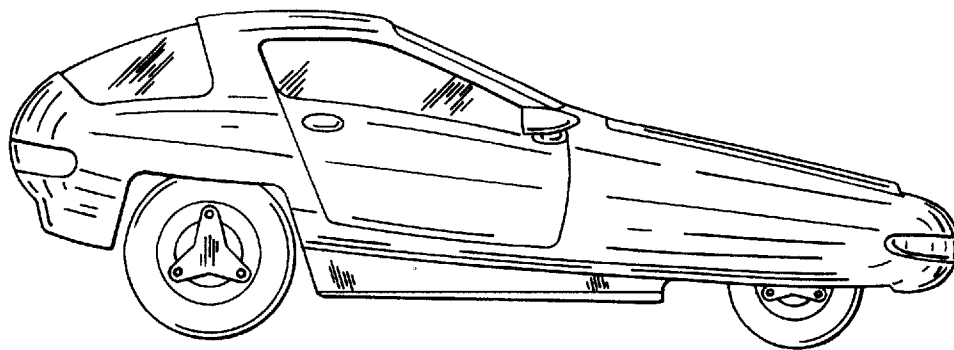

FIG. 1

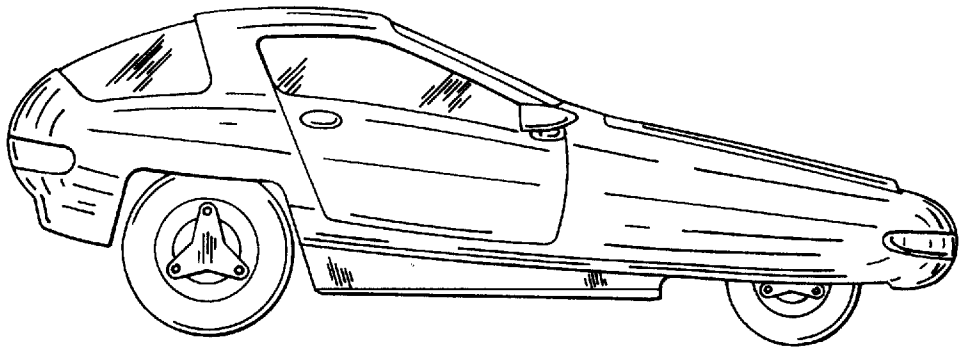

FIG. 2

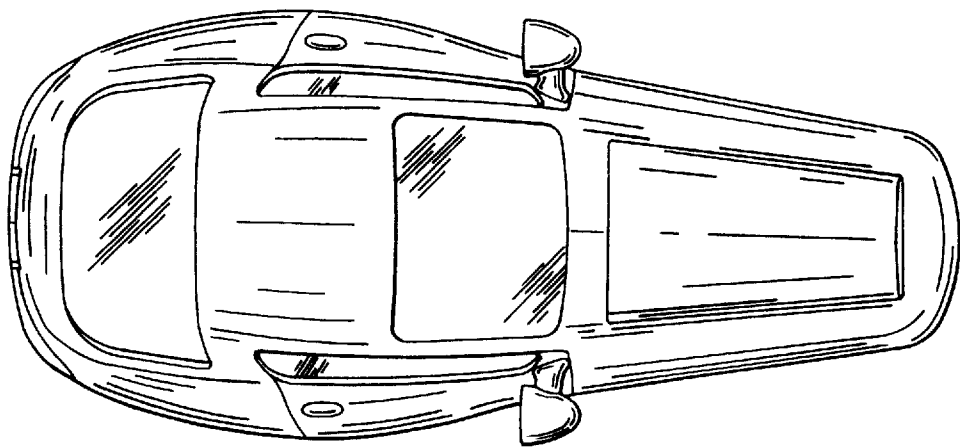

FIG. 3

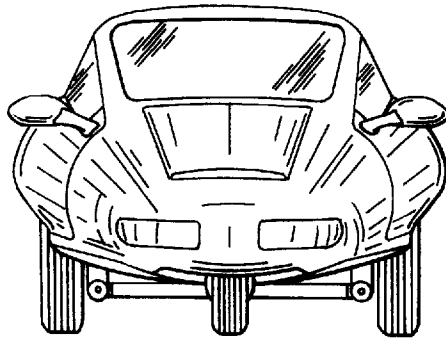

FIG. 4

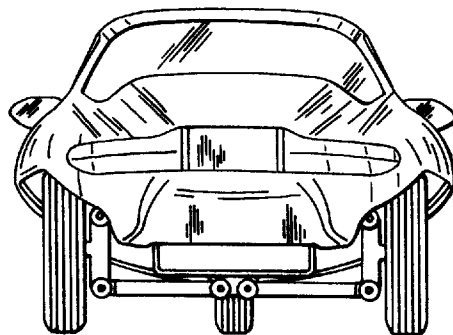

FIG. 5

