

(19) World Intellectual Property Organization
International Bureau



(43) International Publication Date
27 February 2003 (27.02.2003)

PCT

(10) International Publication Number
WO 03/015648 A1

(51) International Patent Classification⁷: **A61B 17/70**

(21) International Application Number: PCT/US01/41684

(22) International Filing Date: 13 August 2001 (13.08.2001)

(25) Filing Language: English

(26) Publication Language: English

(71) Applicant and

(72) Inventor: **MCKINLEY, Laurence, M.** [US/US]; P.O. Box 2790, Rancho Santa Fe, CA 92067 (US).

(74) Agent: **PECK, John, W.**; Christie, Parker & Hale, LLP, Suite 500, 350 West Colorado Boulevard, P.O. Box 7068, Pasadena, CA 90019-7068 (US).

CZ, DE, DK, DM, DZ, EC, EE, ES, FI, GB, GD, GE, GH, GM, HR, HU, ID, IL, IN, IS, JP, KE, KG, KP, KR, KZ, LC, LK, LR, LS, LT, LU, LV, MA, MD, MG, MK, MN, MW, MX, MZ, NO, NZ, PL, PT, RO, RU, SD, SE, SG, SI, SK, SL, TJ, TM, TR, TT, TZ, UA, UG, UZ, VN, YU, ZA, ZW.

(84) Designated States (regional): ARIPO patent (GH, GM, KE, LS, MW, MZ, SD, SL, SZ, TZ, UG, ZW), Eurasian patent (AM, AZ, BY, KG, KZ, MD, RU, TJ, TM), European patent (AT, BE, CH, CY, DE, DK, ES, FI, FR, GB, GR, IE, IT, LU, MC, NL, PT, SE, TR), OAPI patent (BF, BJ, CF, CG, CI, CM, GA, GN, GQ, GW, ML, MR, NE, SN, TD, TG).

Published: — with international search report

For two-letter codes and other abbreviations, refer to the "Guidance Notes on Codes and Abbreviations" appearing at the beginning of each regular issue of the PCT Gazette.

(81) Designated States (national): AE, AG, AL, AM, AT, AU, AZ, BA, BB, BG, BR, BY, BZ, CA, CH, CN, CO, CR, CU,

(54) Title: VERTEBRAL ALIGNMENT AND FIXATION ASSEMBLY

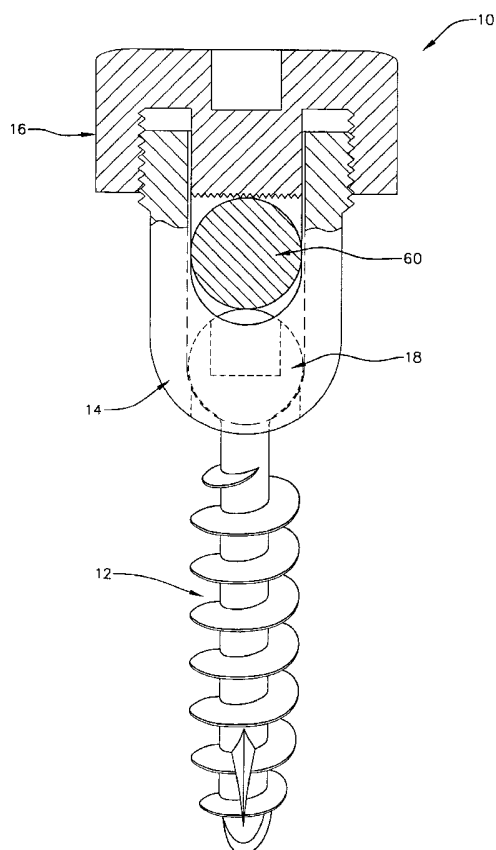

(57) Abstract: A method and apparatus for aligning and fixing vertebral bodies is provided. The vertebral alignment/fixation assembly (10) of the current invention comprises a hemispherical headed pedicle screw (12) disposed within a slotted coupling unit (14) designed to allow angular adjustment of the pedicle screw (12) up to 90 degrees and which may be securely locked into position via a single threaded locking nut (16) once a standard alignment rod (60) has been inserted into the slotted coupling unit (14). The vertebral alignment/fixation assembly (10) enabling the angular adjustment of the fixation system hardware after final placement and insertion of the pedicle screw (12) into the vertebral body. A system and method for aligning and fixing vertebral bodies using the vertebral alignment/fixation assembly of the invention is also provide.



WO 03/015648 A1

VERTEBRAL ALIGNMENT AND FIXATION ASSEMBLY

1

FIELD OF THE INVENTION

The present invention relates generally to a method and apparatus for alignment and fixation of vertebral bodies.

5

BACKGROUND OF THE INVENTION

10

Pedicle screws allow spine surgeons to attach rods or plates to the thoracic and lumbar spine. This rigidly immobilizes the spine segments, promoting the bone graft to grow into a fusion, welding spinal segments into one solid unit, reducing pain and stabilizing deformity without requiring complete immobilization of the patient for the extended period of time during the healing process.

15

While many different pedicle screws have been developed, presently most pedicle screws are fixed axis devices which must be carefully aligned during insertion and fixation in the spine. Specifically, the screws must be drilled or screwed into the bone at a very specific angle to assure that the alignment hardware is exactly positioned such that the receiving portions of the fixation hardware are aligned so that the rod can be passed therethrough without distorting the screw or putting an undesirable level of stress on the attachment point. As a result, the alignment procedure requires a considerable amount of time, increasing the possibilities of complications during surgery and, in many cases the alignment fails and must be repeated. Further, the insertion of the screw is dependent on the angle of alignment required, resulting in insertions that are not in the most secure or safe positions with respect to the vertebral bodies.

20

The art contains a variety of pedicle screws which permit a level of freedom with respect to the alignment of the screw and the coupling element. However, these teachings have generally been complex, and inadequately reliable with respect to durability. The considerable drawbacks associated with the prior art systems include limited angular adjustability, complexity, difficult of properly positioning the coupling elements and the rod, tedious manipulation of the many parts associated with the complex devices and the considerable cost associated with manufacturing such complex mechanisms.

25

30

Accordingly, a need exists for an inexpensive, durable and simple vertebral alignment assembly that allows a surgeon to freely manipulate the alignment of the coupling hardware such that the fixation rods can be properly positioned with respect to the vertebral bodies without a time consuming and potentially dangerous alignment procedure.

35

SUMMARY OF THE INVENTION

1 The present invention relates generally to a method and apparatus for aligning and
fixing vertebral bodies. More specifically, the present invention is directed to a vertebral
alignment/fixation assembly and method which allows a surgeon to manipulate and align the
unit coupling the fixation hardware with the pedicle screw, the assembly comprising a
5 hemispherical headed pedicle screw disposed within a slotted coupling unit designed to allow
angular adjustment of the pedicle screw up to 90° and which may be securely locked into
position via a single threaded locking nut once a standard alignment rod has been inserted
into the slotted coupling unit. The vertebral alignment/fixation assembly enabling the angular
adjustment of the fixation system hardware after final placement and insertion of the pedicle
10 screw into the vertebral body.

 In one embodiment, the vertebral alignment/fixation assembly of the current invention
generally consists of three main components: a hemispherical pedicle screw, a slotted
coupling unit designed to receive the pedicle screw and an alignment rod, and a securing nut
for fixing the angular position of the coupling unit and the position of the alignment rod
15 within the coupling unit.

 In one alternative exemplary embodiment, the pedicle screw of the invention has a
slotted tip to allow the screw to self-tap the vertebral body and thereby ease the insertion of
the screw into the bone.

 In another exemplary embodiment the portion of the securing nut which engages the
20 alignment rod is textured to provide a more secure grip of the alignment rod.

 In still another exemplary embodiment the securing nut has an annular channel
disposed such that a screw driver can be inserted therethrough and interact with the pedicle
screw to drive the screw into a vertebral body.

 In yet another exemplary embodiment the pedicle screw is provided with a square
25 opening in its hemispherical head such that a square headed driving tool can be mated
therewith to drive the screw into the vertebral body.

 In still yet another exemplary embodiment the components of the system are made
from an orthopaedically suitable material, such as, for example, stainless steel or titanium.

 In still yet another preferred embodiment, the invention is directed to a system for
30 aligning and fixing vertebral bodies comprising a multiplicity of vertebral alignment
components as described above attached at suitable points of attachment as determined by the
deformity of the spine.

 In still yet another embodiment, the invention is directed to a method for aligning
vertebral bodies. The method comprises manipulating, aligning and fixing the spine using
35 a vertebral alignment system as described above.

BRIEF DESCRIPTION OF THE DRAWINGS

1 These and other features and advantages of the present invention will be better understood by reference to the following detailed description when considered in conjunction with the accompanying drawings wherein:

5 FIG. 1 is a side view of an embodiment of an unassembled pedicle screw according to the invention.

 FIG. 2a is a side view of an embodiment of a partially assembled pedicle screw according to the invention.

 FIG. 2b is a front view of an embodiment of a partially assembled pedicle screw according to the invention.

10 FIG. 2c is a front partial cross-sectional view of an embodiment of a partially assembled pedicle screw according to the invention.

 FIG. 3a is a top view of an embodiment of a securing nut according to the invention.

 FIG. 3b is a cross section of an embodiment of a securing nut according to the invention.

15 FIG. 3c is a side view of an embodiment of a securing nut according to the invention.

 FIG. 4a is a side view of the interrelation of an embodiment of a pedicle screw and screw driver according to the invention.

 FIG. 4b is a cross section of the interrelation of an embodiment of a pedicle screw and screw driver according to the invention.

20 FIG. 5 is a side view of an assembled pedicle screw according to the invention.

 FIG. 6 is a schematic view of the manipulation and alignment of the spine utilizing an embodiment of the vertebral alignment/fixation system according to the invention.

 FIG. 7 is a schematic view of the manipulation and alignment of the spine utilizing an embodiment of the vertebral alignment/fixation system according to the invention.

DETAILED DESCRIPTION OF THE INVENTION

 The present invention relates generally to a method and apparatus for aligning and fixing vertebral bodies. More specifically, the present invention is directed to a system and method which allows a surgeon to manipulate the angular alignment of the fixation hardware of a vertebral alignment/fixation system after insertion and fixation of the pedicle screws into the vertebral bodies using freely rotatable couplers mounted to hemispherical pedicle screws. The system and method is further designed to enable the fixation of the angular alignment and installation and fixation of the alignment rods to the couplers by application of a single securing nut.

1 As shown in FIGs 1 to 5, the vertebral alignment/fixation assembly **10** of the current invention consists of three main components: a hemispherical pedicle screw **12**, a coupler unit **14** which functions as a universal joint, and a securing nut **16**.

5 The hemispherical pedicle screw **12**, as shown in FIG. 1, comprises a substantially hemispherical head portion **18**, a neck portion **20** and a shaft portion **22**. Although in FIG. 1 the shaft **22** is shown as having a generally cylindrical body **24** and a tapered tip **26** with a thread **28** disposed along the length of the shaft **22**, any shaft design, thread pitch or tip taper suitable for insertion into a vertebral body can be utilized in the current invention. In the embodiment shown in FIG. 1, the tapered tip **26** of the pedicle screw shaft **22** further comprises a slotted groove **30** running longitudinally along the shaft, designed such that the screw is self-tapping easing the insertion of the pedicle screw **12** into the vertebral body.

10 The head portion **18** of the pedicle screw **12** comprises a substantially hemispherical shape. The substantially hemispherical shape of the head portion **18** of the screw **12** is a portion or section of a sphere. Although in the embodiment shown, the section or portion of the sphere comprising the head **18** of the screw **12** is greater in extent than a hemisphere, it should be understood that any external contour which is equidistant from a center point of the head portion **18** could be utilized. In the embodiment shown in FIG. 1, the major cross-section of the substantially hemispherical head portion **18** includes at least 270 degrees of a circle.

15 The hemispherical head portion **18** also has a recess **32** disposed therein (shown in phantom in FIG. 1). The recess **32** defines an engagement point for the application of torque from a torque driving tool **33** for driving the screw **12** into a bone. The specific shape of the recess **32** may be chosen to cooperate with any suitable screw-driving tool **33**, as shown in FIGs. 4a and 4b. For example, the recess **32** may comprise a slot for a flat-headed screwdriver, a crossed recess for a phillips head screwdriver, a hexagonally shaped hole for receiving an allen wrench, or a "figure-8" shaped driver. In a preferred embodiment, a square-headed hole for a square screwdriver or socket-type wrench is utilized. Although the recess **32** is shown to be co-axial with the general elongate axis of the screw shaft **22**, it should be understood that any arrangement of recess **32** and screw **12** can be utilized such that sufficient torque may be applied to the screw **12** to drive it into a bone.

20 The head portion **18** of the screw **12** is connected to the shaft portion **22** at a neck portion **20**. In relation to each other, the diameter of the shaft **22** should be less than the diameter of the semi-spherical head **18**, and the neck **20** of the screw **12** should be preferably narrower than the widest portion of the shaft **22**. A pedicle screw **12** according to the invention having such dimensional relationships is preferable because the screw may be locked at a variety of angles with relation to the coupling unit **14** while still being securely

1 joined to the coupling element **14** (embodiments of which are shown in FIGs. 1, 2 and 5).
Although any biocompatible material having suitable strength and durability characteristics
may be utilized, the pedicle screw **12** is preferably made from surgical grade titanium or
stainless steel.

5 One exemplary embodiment of the universal joint coupling element **14** of the present
invention is shown in a side view in FIG. 1, critical elements are shown in phantom. The
coupling element **14** comprises a generally cylindrical tubular body which defines an inner
passage **34** having an inner wall **36**. The inner passage **34** comprises an upper generally
cylindrical portion **38** and an inwardly curved lower portion **40**. The inwardly curved lower
portion **40** defines a socket, into which the head **18** of the screw **12** may rotatably engage.
10 The bottom surface **42** of the coupling element **14** includes an opening **44** defining a passage
46 such that the shaft **22** of the screw **12** may extend therethrough and pass outside the body
of the coupling element **14**. To securely engage the screw **12** within the coupling element **14**,
the dimensions of the opening **44** and passage **46**, must be greater than the diameter of the
shaft **22** of the screw **12**, but less than the largest diameter of the head **18**.

15 The cylindrical upper portion **38** of the coupling element **14** includes a pair of
vertically oriented, channels **48** having rounded bottom surfaces **50** and open top portions
disposed on opposing sides of the coupling element **14**. In combination the channels **48** form
engagement point for an elongated fixation rod **60**. In addition the channels **48** divide the
wall **52** of the coupling element **14** into upwardly extending members **54** and **56**. As shown
20 in the embodiment illustrated in FIGs. 1, 2 and 5, the vertical distance from the top **58** of the
channels **48** to the curved bottom **50**, is sufficient to allow the rod **60** which is to be provided
to slidably engage therein such that the rod **60** may be fully nested in the channels **48**. In
addition, the curved bottom **50** of the channels **48** are arranged such that the top of the head
18 of the screw **12**, when fully nested in the lower socket portion **40**, extends above the edge
25 of the curved bottom **50** of the channels **48** such that a rod **60** positioned therein will
pressingly engage the head portion **18** of the screw **12**. The top **58** of the upper portion **38**
of the coupling element **14**, which comprises upwardly extending members **54** and **56**, have
disposed thereon a threading **62**. The upper portion **38**, and the threading **62** thereon, is
ideally suited for threadably engaging a securing nut **16**.

30 FIGs. 2a, 2b and 2c show an additional feature of one exemplary embodiment of the
invention, which allows angular alignment of the screw **12** up to at least a 90 degree angle
with respect to the coupling element **14**. In this embodiment the lower portion **40** of the
coupling unit **14** further comprises a pair of lower slots **63** extending from the opening **44** and
passage **46** in the bottom surface **42** of the coupling unit **14**. The lower slots **63** are aligned
35 on opposite sides of the bottom surface **42** of the coupling unit **14** such that in combination

1 the slots 63 define a single 180 degree passage dimensioned to allow the neck portion 20 of
the screw 12 to move therein when the head portion 18 of the screw is fully engaged in the
socket 40 of the coupling unit 14 and the coupling unit 14 is properly oriented with respect
5 to the shaft 22 of the screw 12. As shown, even in this extreme angular position, the coupling
unit 14 is designed such that a rod 60 inserted into the channels 48 will press against the head
portion 18 of the screw 12 and at the urging of the securing nut 16 engage and fix both the
rod 60 and in turn the coupling unit 14 into alignment.

10 The top securing nut 16 is shown in top view in FIG. 3a, in side view in FIG. 3b, and
in cross section in FIG. 3c. The nut 16 comprises an inner threading 64, which is intended to
mate with the threading 62 on the upwardly extending members 54 and 56 of the upper
portion 38 of the coupling element 14. The nut 16 also comprises an inner plug portion 65
having a bottom surface 66 which is intended to seat against the top surface of the rod 60
15 seated in the coupling element 14, providing a means for driving the rod 60 downward and
against the head portion 18 of the screw 12. A central annular opening 68 is provided in the
center of the nut 16 defining a passage 70 passing therethrough, the passage 70 and opening
68 being designed such that the screw driver utilized to drive the screw 12 into the vertebral
body can fit therein and can be utilized to tighten the nut 16 onto the coupling unit 14, as
20 shown in FIG. 4b. Although the embodiment of the passage 70 shown in FIGs. 3a to 3c
terminates in the middle of the plug 65 of the nut 16, the passage 70 could also transect the
plug 65 forming a conduit between the opening 68 and the bottom surface 66.

20 In the preferred embodiment shown in FIG. 1, the bottom surface 66 of the nut 16
further comprises a plurality of raised metal teeth 72 designed to bitingly engage and press
into the rod 60 providing additional frictional engagement between the rod 60 and the
vertebral alignment assembly 10 such that the possibility of a mechanical shock jarring the
rod 60 loose from the vertebral alignment assembly 10 is reduced. In another preferred
25 embodiment, the rod 60 is manufactured with a rolled or corrugated finish to improve the
frictional engagement between the rod 60 and the teeth 72 on the bottom surface 66 of the nut
16.

30 FIGs. 4a and 4b show the engagement of a driver 33 with the vertebral alignment
assembly 10 to first engage the screw 12 into the vertebral body 74, as shown in FIGs. 4a, and
then to engage the securing nut 16 onto the coupling unit 14, as shown in FIG. 4b. As shown
in FIGs. 4a, the coupler unit 14 is designed such that the screw driver 33 can fit inside the
inner passage 34 of the coupler 14 and engage the recess 32 of the head portion 18 of the
screw 12 to drive the screw 12 into the vertebral body 74. As shown in FIG. 4b, the securing
nut 16 is further designed such that the screw driver 33 can engage nut opening 68 to secure
35

1 the nut 16 on the coupling unit 14 and thereby fix alignment rod 60 into coupling unit 14 and further secure the alignment of the coupling unit 14 in relation to the axis of the screw 12.

5 Referring now to FIG. 5, the coupling element 14 is shown with the screw 12 inserted therethrough, and the head 18 of the screw 12 nested in the lower socket portion 40 of the coupling element 14. The shaft portion 22 of the screw 12 is inserted downward, through the interior passage 34 of the coupling element 14, and out through the opening 44. In this position, the curved undersurface of the head portion 18 rests against the inwardly curved bottom surface 42 of the lower socket portion 40, and is prevented from translating further downward by the dimensions of the opening 44. Meanwhile, the uppersurface of the head portion 18 is pressed against the rod 60 which is pressed into the head portion 18 by securing nut 16 thereby simultaneously preventing the rod 60 from moving out of the coupling unit 14 and preventing the coupling unit 14 from moving relative to the screw 12.

10 FIGs. 6 and 7, show a side view of the fully locked coupling element, rod, and screw system in relation to a vertebral body 74. FIG. 6 shows the vertebral alignment/fixation assembly 10 of the invention anchored traditionally in a plurality of vertebral bodies with an optional crosslink stabilizing bar. FIG. 7 shows the vertebral alignment/fixation assembly 10 of the invention anchored into the ileum bone with the screw 12 aligned at a 90° angle with reference to the coupling unit 14. With reference to these Figures, the preferred method of assembly and alignment of vertebral bodies is described.

15 First, a pre-drilled hole 76 is provided in the bone 74, into which the screw 12 is to be anchored. The hole 76 may be pretapped, or, as described above, the external threading 28 at the tip portion 24 of the screw 12 may include a self-tapping slot 30. In either case, during assembly, the tip 26 of the screw 12 is inserted through the interior passage 34 of the coupling element 14 until the shaft 22 of the screw 22 extends out of the coupling element 14 and the head 18 of the screw 12 is engaged in the lower socket portion 40 of the coupling unit 14. At this point in the assembly process, the coupling element 14 has the capacity to rotate relative to the screw 12. A screw-driving tool 33 is then aligned with the recess 32 in the head 18 of the screw 12 so that it may be driven into the preformed hole 76 in the bone 74.

20 After the screw 12 has been driven into the hole 76, the coupling element may be rotated relative to the screw 12, to align the coupling element 14 such that a support rod 60 may be engaged within the rod receiving channel 48 and properly aligned according to the surgeon's wishes. As shown best in FIG. 5, and previously discussed, the bottom of the rod 60 seats on the top of the head portion 18 of the screw 12, and not fully on the bottom curved surface 50 of the channels 48.

25 After the rod 60 is positioned within the coupling element 14, the top locking nut 16 is threaded onto the threading 62 of the upwardly extending members 54 and 56. The nut 16

1 is then screwed down onto the coupling element 14 until the lower surface 66 of the engaging
portion 65 of the nut 16 seats against the top surface of the rod 60. As the nut 16 descends
onto the coupling element 14, the rod 60 is driven downward by the engaging portion 65 of
the nut 16, causing the rod 60 to engage the head 18 of the screw 12 and to push the head
5 portion 18 of the screw 12 downward pressingly engaging it within the socket 40 of the
coupling element 14. This downward translation permits the bottom of the rod 60 to seat
against the bottom surface 50 of the channels 48, and causes the head 18 of the screw 12 to
be crush locked to the inwardly curved surface 40 of the coupling element 14. The force also
engages the teeth 72 of the nut 16 into the rod 60 providing additional frictional engagement
10 between the coupling element 14 and the rod 60. As such, the downward force of the bottom
surface 66 of the nut 16 against the rod 60, as well as the teeth 72 and the counter-force
provided by the bottom surface 50 of the channels 48 causes the rod 60 to be locked. This
locking prevents the rod 60 from sliding relative to the assembled vertebral alignment
assembly 10, locking the rod 60 to the coupling element 14, as well as the screw 12 to the
coupling element 14.

15 In addition to these basic components, fixation hardware could also be provided to fix
the spine into the desired alignment. The fixation hardware may comprise clamps, which are
designed to mate with the top or side of the pedicle screw, bendable fixation rods or plates,
which run between the clamps on the various pedicle screws attached either to different
vertebral bodies or at different points on a single vertebral body, and bolts, also designed to
20 mate with the clamps such that the clamps can be tightened onto and fix the fixation rods into
place. In addition, as shown in FIG. 6 the fixation hardware may comprise crosslinks of any
design suitable for attachment to the alignment assembly 10 of the current invention. For
example, although the crosslink shown in FIG. 6 is of fixed dimension, slotted crosslinks may
also be used for applications in which the distance between the fixation points of the crosslink
25 must be changed. In such an embodiment, the openings in the crosslink for attaching it to the
alignment assembly 10 (which are shown as simple holes in FIG. 6) comprise elongated slots
such that the crosslink may be slid relative to the alignment assembly 10 along the length of
the slot, thereby allowing for some degree of adjustment in the position of the crosslink
relative to the alignment assembly.

30 All of the above components, including the fixation hardware can be made of any
suitable surgical material, such as, for example, stainless steel or titanium.

Although specific embodiments are disclosed herein, it is expected that persons skilled
in the art can and will design alternative vertebral alignment/fixation screws that are within
the scope of the following claims either literally or under the Doctrine of Equivalents.

WHAT IS CLAIMED IS:

1

1. A vertebral alignment/fixation assembly comprising:

5

a screw comprising an elongated threaded shaft defining a screw axis with a substantially hemispherical head having a driver engaging recess disposed therein arranged at one end of the shaft and a tapered tip arranged at the other end of the shaft;

10

a coupling element comprising a cylindrical body having an exterior threading disposed on said upper surface and defining an axial bore through which said screw may be inserted, said bore having a narrowing inwardly curve lower surface defining a socket designed to engage the substantially hemispherical head of the screw such that the head of the screw is prevented from passing therethrough and such that the screw may be rotated therein to adjust the angle between the axis of the screw and the axis of the bore, said coupling element further comprising a pair of opposing upper channels formed in the top of said coupling element such that an elongated rod may be received therein and a pair of opposing lower channels formed in the bottom of said coupling element designed to allow the shaft of the screw to move therethrough, the lower channels being designed such that the angle between the axis of the screw and the axis of the coupling element can be adjusted to at least 90 degrees; and

15

20

a securing nut, mateable with said external threading, the nut having an engaging portion designed to fit within the bore to engage the elongated rod, the engaging portion further comprising a plurality of engaging teeth designed to frictionally lock the rod within the upper channel of the coupling element.

25

2. A vertebral alignment/fixation assembly as described in claim 1, wherein the angles between the axis of the screw and the axis of the coupling element can be adjusted to at least 100 degrees.

30

3. A vertebral alignment/fixation assembly as described in claim 1, wherein the assembly is made of stainless steel.

4. A vertebral alignment/fixation assembly as described in claim 1, wherein the recess is designed to receive a screw driver from the group consisting of: flat-headed, phillips head, allen wrench, and square headed.

35

5. A vertebral alignment/fixation assembly as described in claim 1, wherein the nut further comprises an axial recess identical to the recess disposed on the screw head.

1 6. A vertebral alignment/fixation assembly as described in claim 5, wherein the
nut recess is designed to receive a screw driver from the group consisting of: flat-headed,
phillips head, allen wrench, and square headed.

5 7. A vertebral alignment/fixation assembly as described in claim 1, wherein the
screw further comprises a slotted groove disposed longitudinally along the tip and designed
to allow the screw to be self-tapped.

8. A vertebral alignment/fixation system comprising:

at least one elongated rod; and

10 at least one vertebral alignment/fixation assembly comprising:

 a screw comprising an elongated threaded shaft defining a screw axis
with a substantially hemispherical head having a driver engaging recess
disposed therein arranged at one end of the shaft and a tapered tip arranged at
the other end of the shaft,

15 a coupling element comprising a cylindrical body having an exterior
threading disposed on said upper surface and defining an axial bore through
which said screw may be inserted, said bore having a narrowing inwardly curve
lower surface defining a socket designed to engage the substantially
hemispherical head of the screw such that the head of the screw is prevented
20 from passing therethrough and such that the screw may be rotated therein to
adjust the angle between the axis of the screw and the axis of the bore, said
coupling element further comprising a pair of opposing upper channels formed
in the top of said coupling element such that an elongated rod may be received
therein and a pair of opposing lower channels formed in the bottom of said
25 coupling element designed to allow the shaft of the screw to move
therethrough, the lower channels being designed such that the angle between
the axis of the screw and the axis of the coupling element can be adjusted to at
least 90 degrees, and

30 a securing nut, mateable with said external threading, the nut having an
engaging portion designed to fit within the bore to engage the elongated rod, the
engaging portion further comprising a plurality of engaging teeth designed to
frictionally lock the rod within the upper channel of the coupling element.

35

1 9. A vertebral alignment/fixation system as described in claim 8, wherein the
angles between the axis of the screw and the axis of the coupling element can be adjusted to
at least 100 degrees.

5 10. A vertebral alignment/fixation system as described in claim 8, wherein the
system components are made of stainless steel.

10 11. A vertebral alignment/fixation system as described in claim 8, wherein the
recess is designed to receive a screw driver from the group consisting of: flat-headed, phillips
head, allen wrench, and square headed.

15 12. A vertebral alignment/fixation system as described in claim 8, wherein the nut
further comprises an axial recess identical to the recess disposed on the screw head.

20 13. A vertebral alignment/fixation system as described in claim 12, wherein the nut
recess is designed to receive a screw driver from the group consisting of: flat-headed, phillips
head, allen wrench, and square headed.

25 14. A vertebral alignment/fixation system as described in claim 8, wherein the
screw further comprises a slotted groove disposed longitudinally along the tip and designed
to allow the screw to be self-tapped.

30 15. A vertebral alignment/fixation system as described in claim 8, further
comprising at least one piece of fixation hardware designed to engage the at least one
vertebral alignment/fixation assembly, the fixation hardware selected from the group
consisting of: crosslinks, clamps, plates and rods.

35 16. A vertebral alignment/fixation method comprising:
providing a vertebral alignment/fixation system as described in claim 8;
inserting the screw into the coupling element such that the head of the screw engages
the socket of the coupling element;
driving the screw into a vertebral body;
inserting a rod into the upper channels of the coupling unit;
angularly aligning the coupling unit and rod with the vertebral body;
tightening a securing nut onto the coupling unit such that the engaging portion of the
nut pressingly engages the rod, forcing the rod into the head of the screw thereby fixedly

1 attaching the rod within the coupling element and preventing the coupling element from being
angularly rotated with respect to the screw.

5 17. A vertebral alignment/fixation method comprising utilizing a vertebral
alignment/fixation system as described in claim 8 to align at least one vertebral body.

10 18. A vertebral alignment/fixation method comprising utilizing a plurality of
vertebral alignment/fixation assemblies as described in claim 1 to align at least one vertebral
body.

10

15

20

25

30

35

1/8

FIG. 1

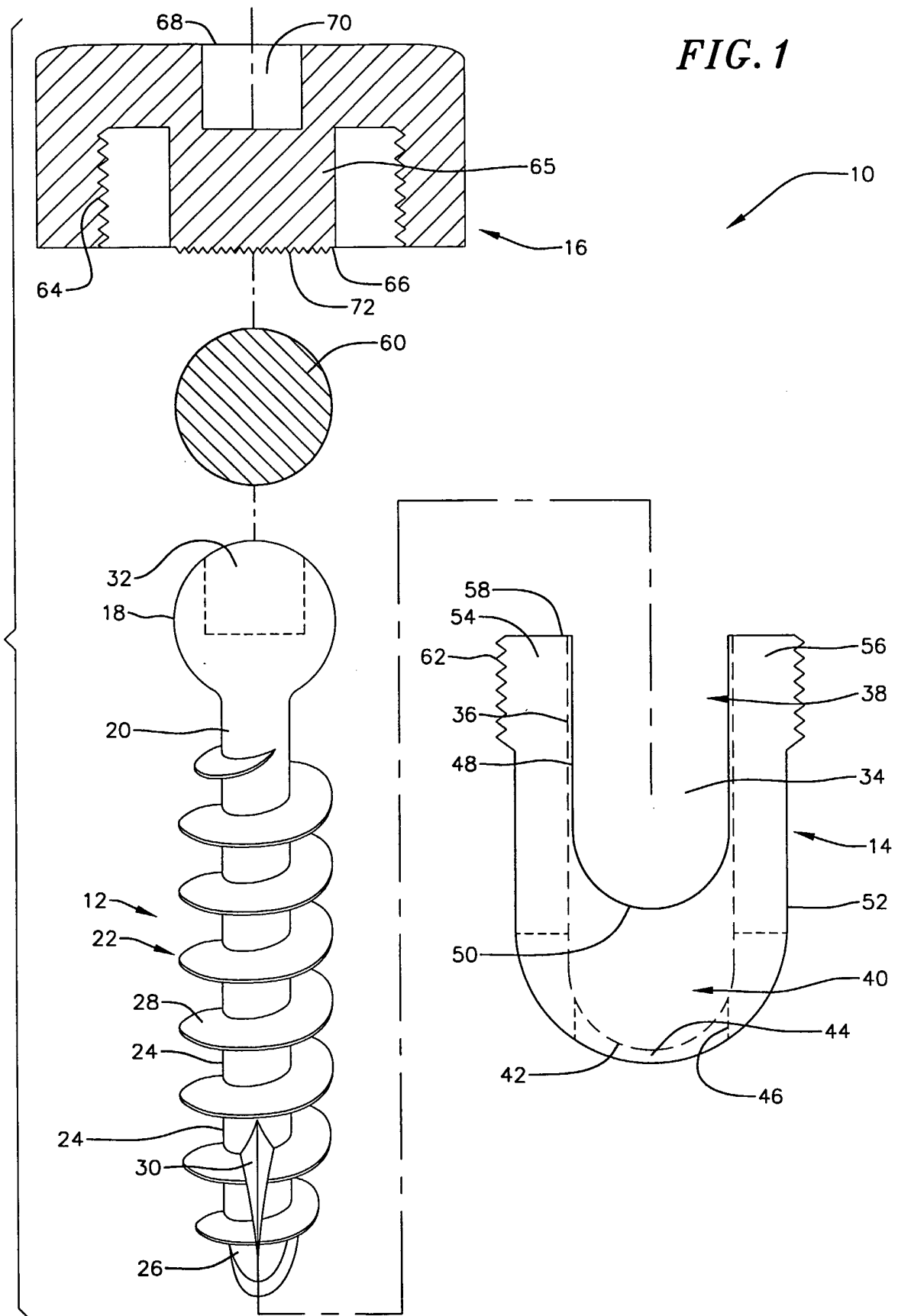

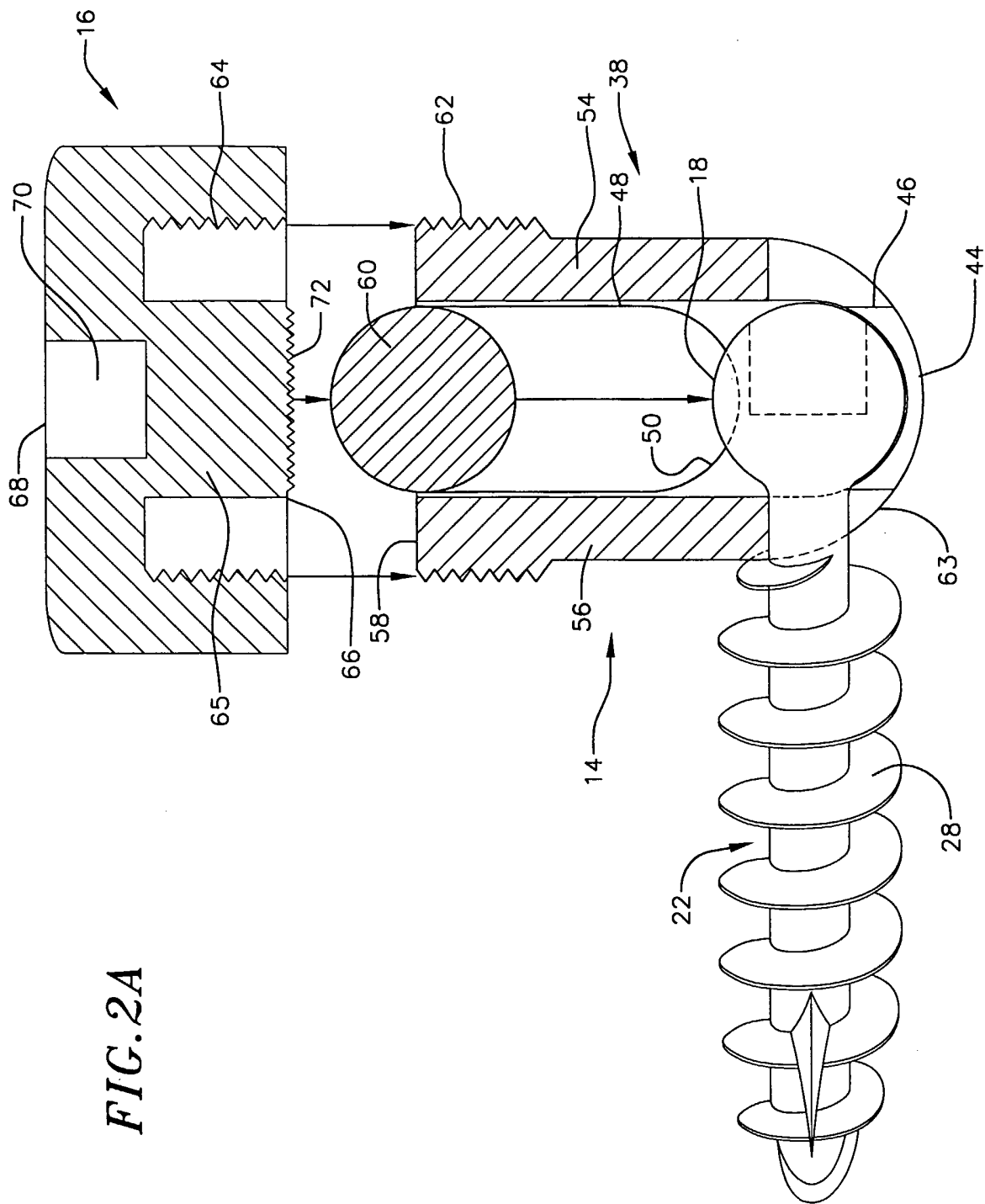

FIG. 2A

FIG. 2C

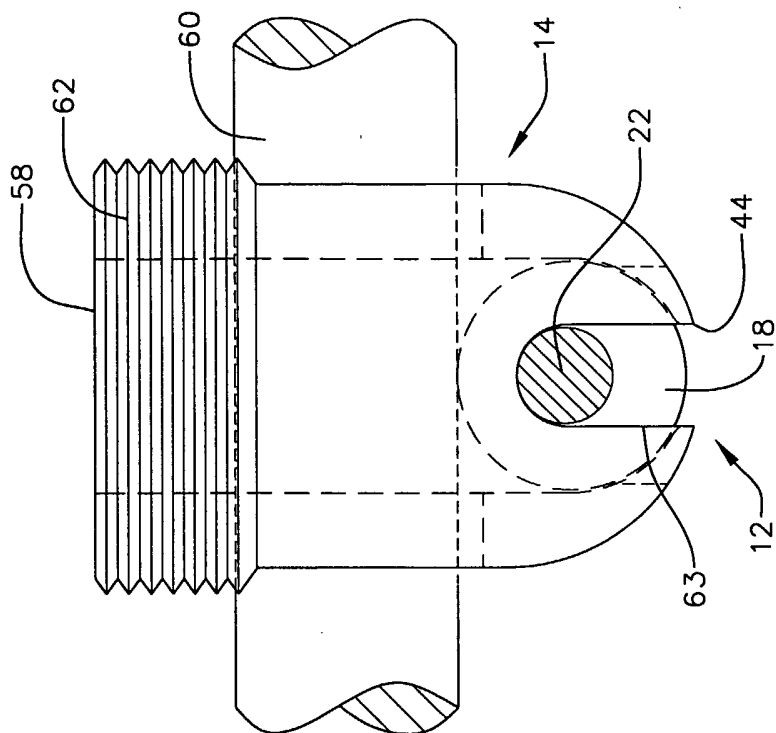
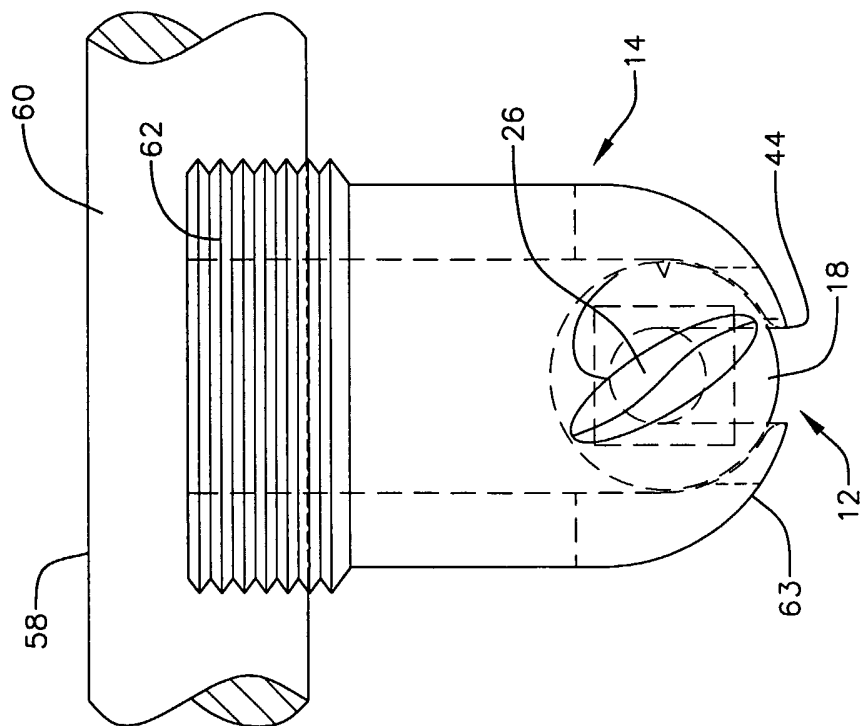

FIG. 2B



4/8

FIG. 3A

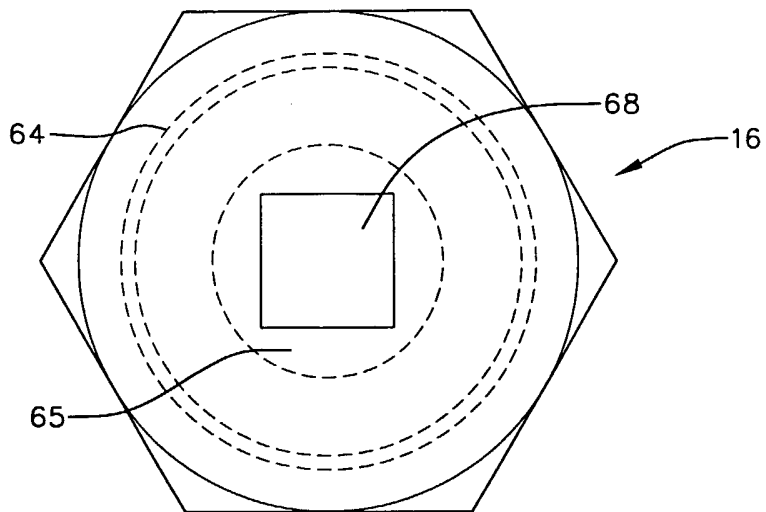

FIG. 3B

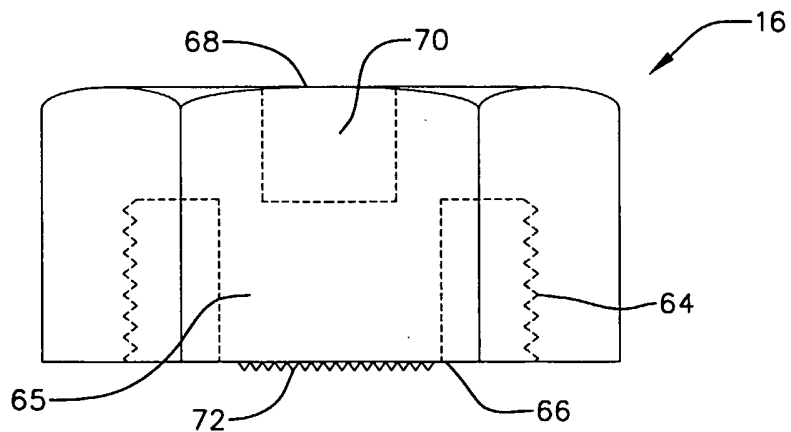

FIG. 3C

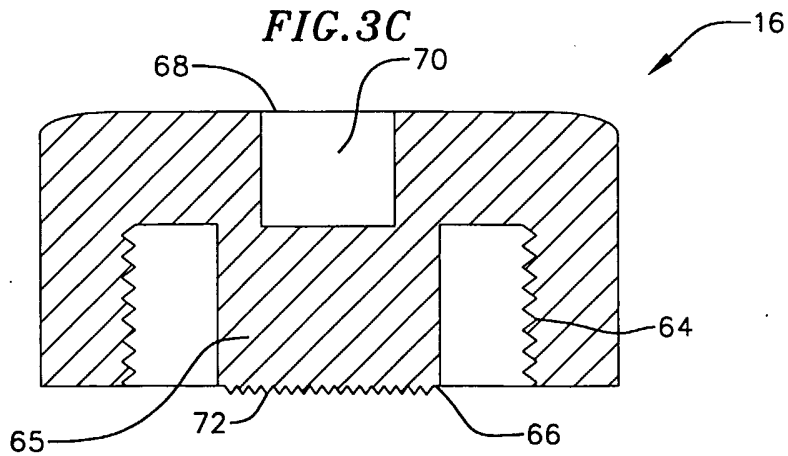
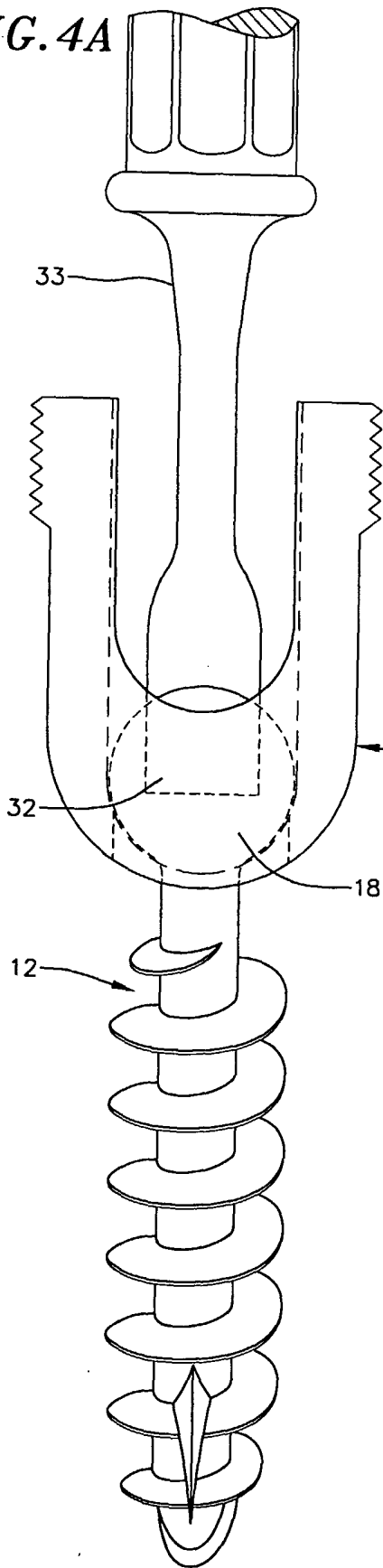
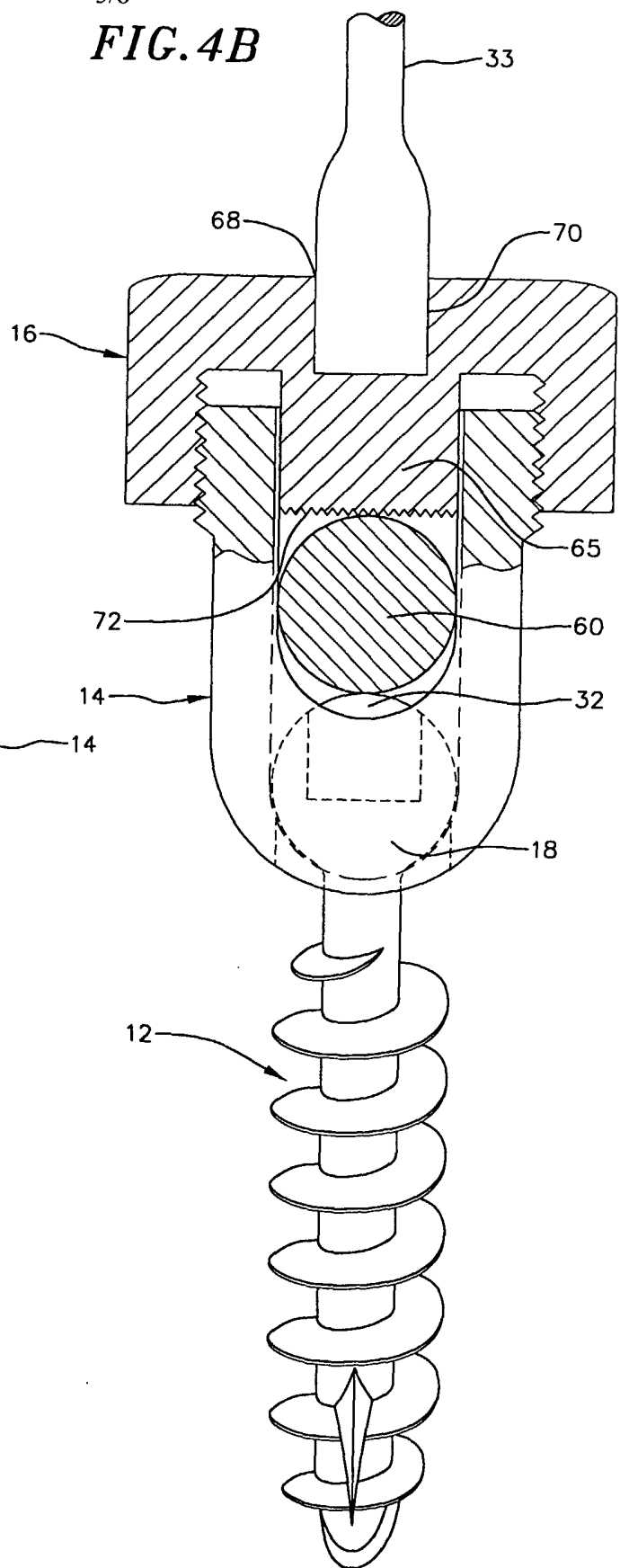

FIG. 4A



5/8

FIG. 4B



6/8

FIG. 5

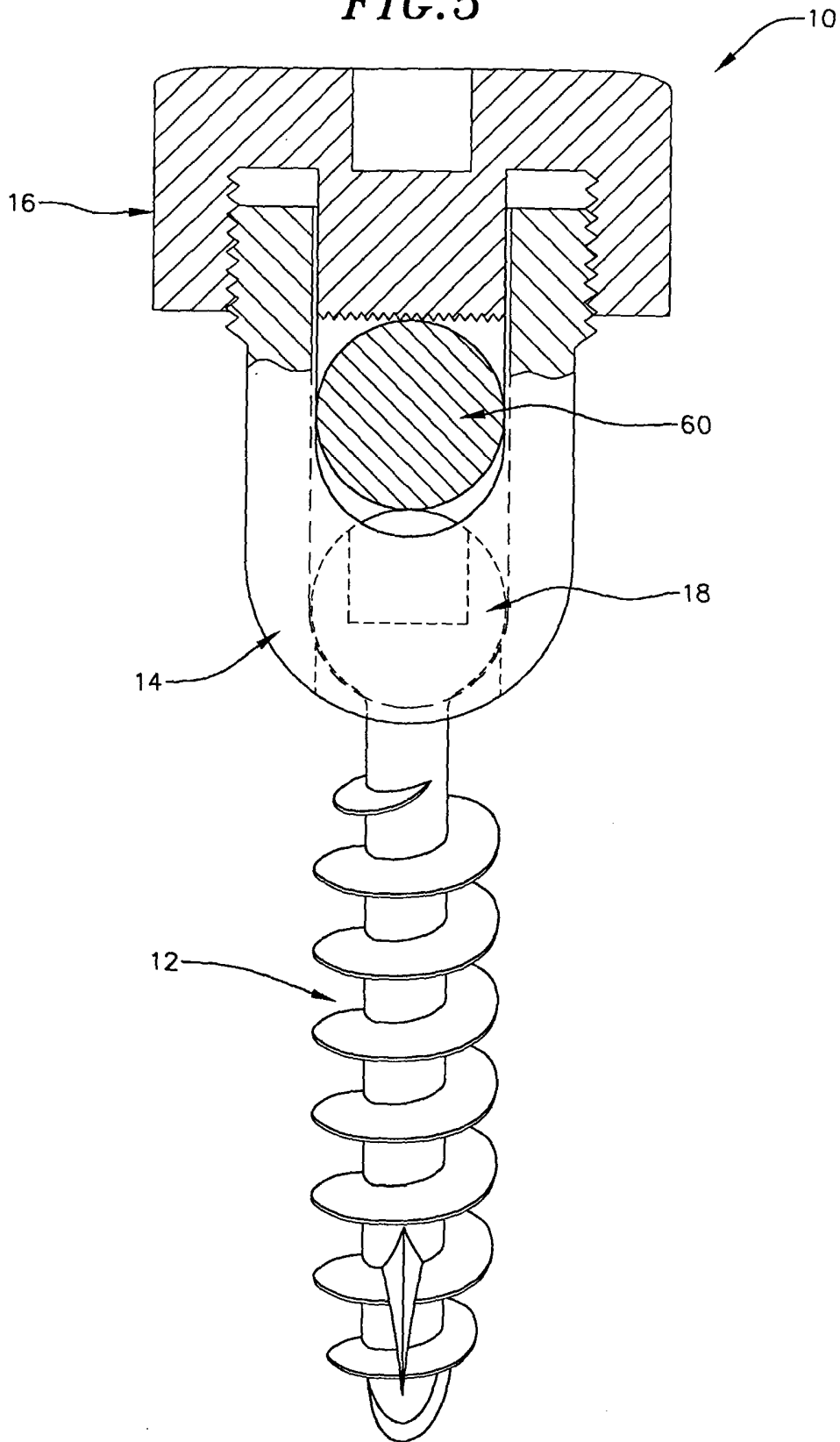

FIG. 6

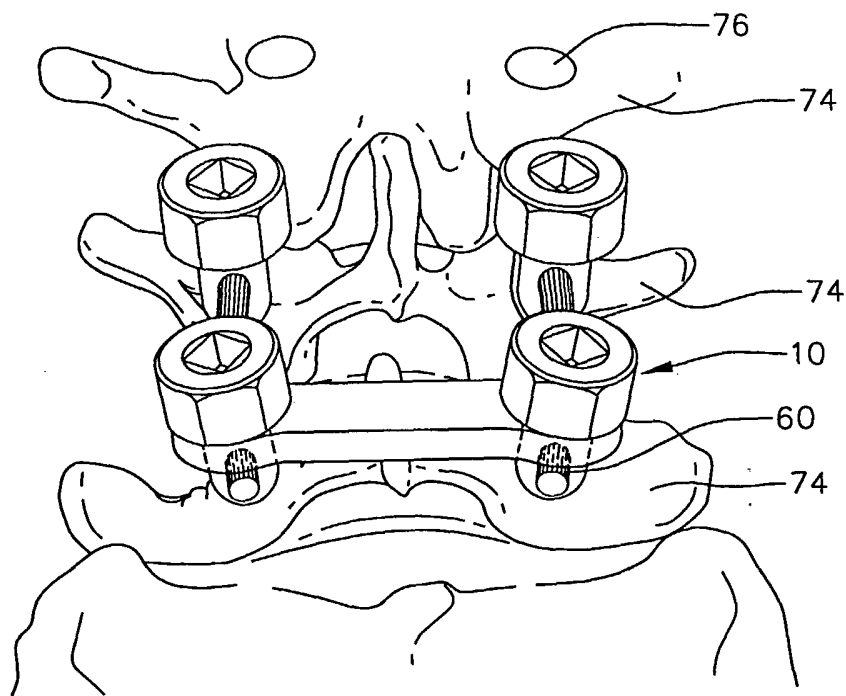
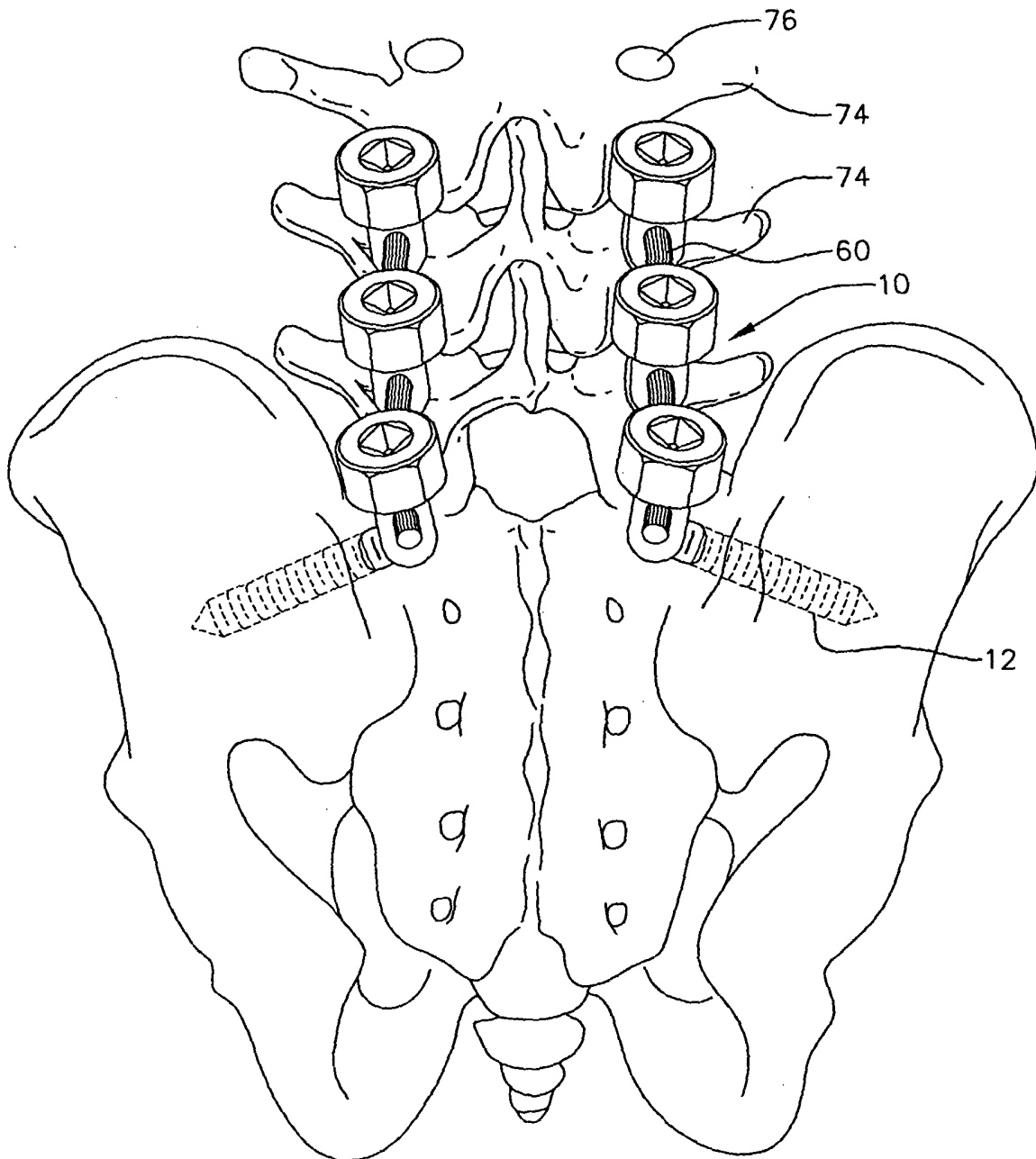

FIG. 7



INTERNATIONAL SEARCH REPORT

International application No.
PCT/US01/41684

A. CLASSIFICATION OF SUBJECT MATTER
 IPC(7) :A61B 17/70
 US CL :606/61
 According to International Patent Classification (IPC) or to both national classification and IPC

B. FIELDS SEARCHED

Minimum documentation searched (classification system followed by classification symbols)

U.S. : 606/61, 60, 69, 70,71,72,73

Documentation searched other than minimum documentation to the extent that such documents are included in the fields searched

Electronic data base consulted during the international search (name of data base and, where practicable, search terms used)

C. DOCUMENTS CONSIDERED TO BE RELEVANT

Category*	Citation of document, with indication, where appropriate, of the relevant passages	Relevant to claim No.
A	US 6,132,432 A (Richelsoph) 17 October 2000, see entire document.	1-18
A	US 6,280,442 B1 (Barker et al.) 28 August 2001, see entire document.	1-18
A	US 6,010,503 A (Richelsoph et al.) 04 January 2000, see entire document.	1-18
A	US 5,882,350 A (Ralph et al.) 16 March 1999, see entire document.	1-18
A	Us 6,132,434 A (Sherman et al.) 17 October 2000, see entire document.	1-18

Further documents are listed in the continuation of Box C. See patent family annex.

* Special categories of cited documents:	"T" later document published after the international filing date or priority date and not in conflict with the application but cited to understand the principle or theory underlying the invention
"A" document defining the general state of the art which is not considered to be of particular relevance	"X" document of particular relevance; the claimed invention cannot be considered novel or cannot be considered to involve an inventive step when the document is taken alone
"E" earlier document published on or after the international filing date	"Y" document of particular relevance; the claimed invention cannot be considered to involve an inventive step when the document is combined with one or more other such documents, such combination being obvious to a person skilled in the art
"L" document which may throw doubts on priority claim(s) or which is cited to establish the publication date of another citation or other special reason (as specified)	"G" document member of the same patent family
"O" document referring to an oral disclosure, use, exhibition or other means	
"P" document published prior to the international filing date but later than the priority date claimed	

Date of the actual completion of the international search 23 OCTOBER 2001	Date of mailing of the international search report 27 DEC 2001
--	--

Name and mailing address of the ISA/US Commissioner of Patents and Trademarks Box PCT Washington, D.C. 20231 Facsimile No. (703) 305-3230	Authorized officer PEDRO PHILOGENE Telephone No. (703) 308-2252
---	--