

(No Model.)

D. SERVIS.
RAILWAY TIE PLATE.

No. 524,868.

Patented Aug. 21, 1894.

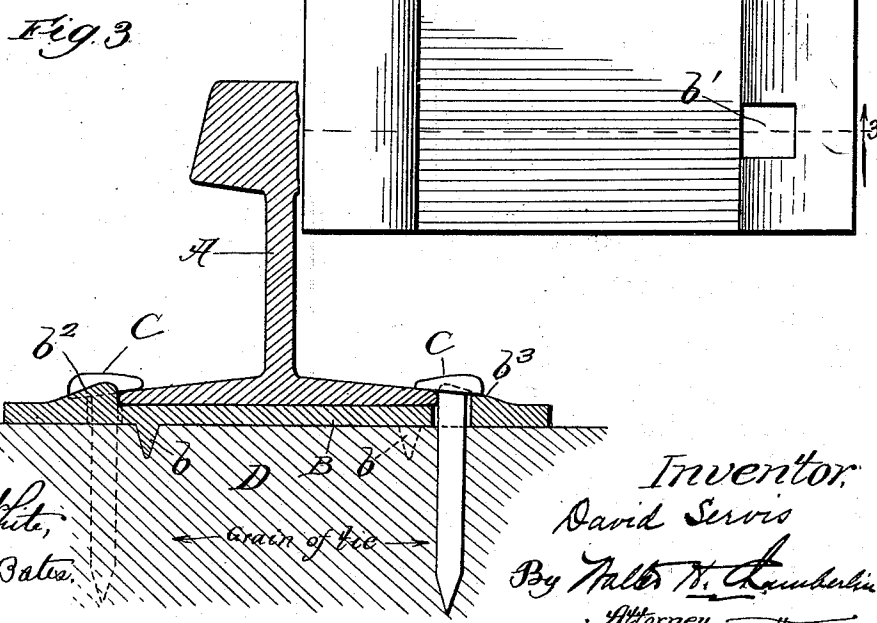
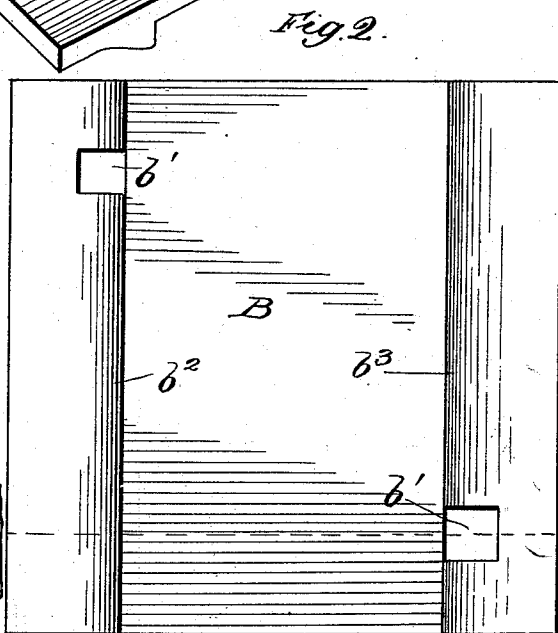
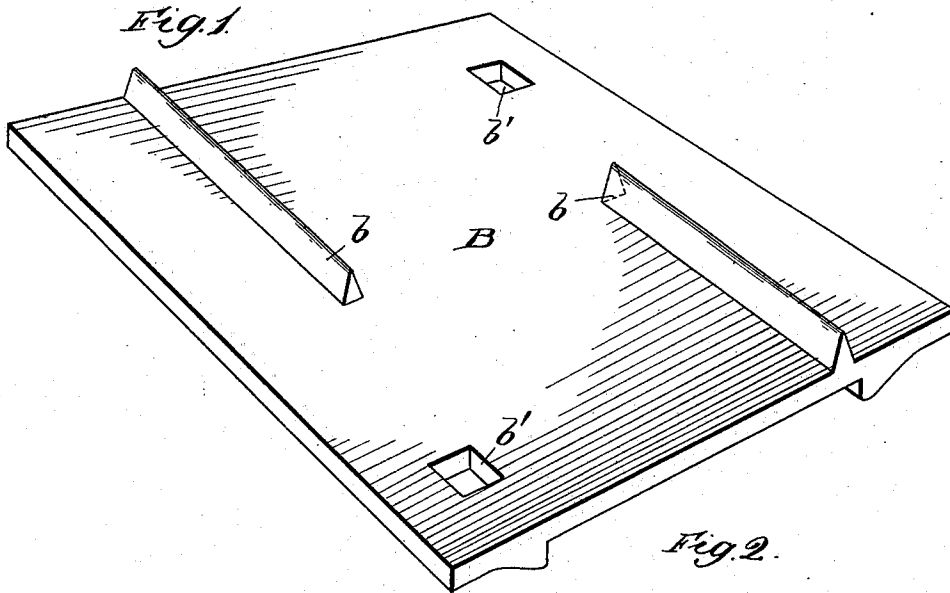

Witnesses;
Clifford N. White,
Albert H. Bates.

Inventor:
David Servis
By *Matt N. Chamberlin*
Attorney.

UNITED STATES PATENT OFFICE.

DAVID SERVIS, OF CHICAGO, ILLINOIS.

RAILWAY-TIE PLATE.

SPECIFICATION forming part of Letters Patent No. 524,868, dated August 21, 1894.

Application filed October 31, 1893. Serial No. 489,597. (No model.)

To all whom it may concern:

Be it known that I, DAVID SERVIS, a citizen of the United States, residing at Chicago, county of Cook, State of Illinois, have invented a certain new and useful Improvement in Railway-Tie Plates; and I declare the following to be a full, clear, and exact description of the invention, such as will enable others skilled in the art to which it pertains to make and use the same, reference being had to the accompanying drawings, which form a part of this specification.

My invention has for its object the production of what is popularly known as a "railway tie plate" that is a plate which is placed between the tie and a railway rail. It consists in a combination of features hereinafter described and claimed.

In the drawings: Figure 1. is a view of the under side of my plate. Fig. 2. is a view of the top of the plate. Fig. 3. is a vertical section on the line 3—3 of Fig. 2 showing the relative positions of the rail, plate and tie.

In carrying out the invention A represents the rail, B the plate, C the spikes and D the tie. On the under side of the plate B are two flanges or ribs or ridges *b* preferably tapering to more or less of, a sharp edge, and located diagonally opposite each other. Each rib extends only half way (more or less) across the plate and in the opposite corners are the spike holes *b'*. Preferably the ribs *b* are immediately under or closely adjacent to the point where the edge of the rail base comes above. These ribs are parallel with the rail and consequently extend across the grain of the tie. On the top side of the plate may if desired be provided the flanges *b*²—*b*³ one on each side of the rail, although these flanges and particularly the flange *b*³ might be dispensed with if desired. Their function is of course to aid the spikes in preventing the rail from lateral movement on the plate.

I now desire to call attention to the essential feature of my invention which consists in the provision of the under side of the plate of the two ribs *b*, alternating with each other, as shown. By means of these ribs, the plate is improved in several respects. Their position substantially under the edges of the rail base prevent the tendency of the plate to buckle beyond the edges of the rail base.

Their position alternating with each other, prevent them from cutting into the same portion of the tie lengthwise, that is prevents them from cutting out a portion of the tie and thus lessen or remove altogether the holding power of the fiber of the tie. By their position across the grain of the tie they effectually hold the plate against any movement lengthwise of the tie and thus prevent any lateral movement of the rail. I would also call attention to the fact that while the ribs *b* alternate with each other, so also do the spike holes alternate with each other and with the ribs. Thus while the advantage of having the rib under the edge of the rail base is obtained, yet the tie is not weakened by having the rib and spike enter adjacent to each other. If such were the case the holding power of each would be greatly weakened. By having the ribs at diagonally opposite corners and the spikes at the other diagonally opposite corners, the plate is held squarely in position and is prevented absolutely from twisting, from buckling, or from moving lengthwise of the tie. So also by the above arrangement the tie is not disintegrated at the points where the greatest solidity is required namely underneath the plate.

I am aware that ribs have heretofore been placed on the under side of the plate, said ribs running both with the grain of the tie and across the same, but where they run parallel with the grain they do not resist effectually the lateral thrust of the rail and where they run across the grain they cut out a portion of the tie and thus weaken it at the point where the greatest solidity is required. I am also aware that it is old to extend a single rib across the grain at the middle of the under side of the plate, but such a construction, because of the fact that the surface of the tie is not always smooth, permits a rocking motion of the plate, thus causing the flange or rib to soon enlarge the recess in the tie in which it rests, causing a play of the plate around the spikes and soon loosening the entire plate. None of the above constructions do I claim as my invention, but

What I claim is—

1. A railway tie plate, provided on its under side with two continuous or unbroken ribs arranged to extend across the grain of the tie

when in position thereon, neither of said ribs extending entirely the width of the plate, and said ribs being out of longitudinal alignment with each other substantially as described.

5 2. A railway tie plate provided on its under side with two ribs arranged to extend across the grain of the tie when in position, said ribs located diagonally opposite each other, so that they enter the tie in different
10 longitudinal portions, substantially as described.

3. A railway tie plate provided on its under side with two ribs arranged to extend

across the grain of the tie, when in position thereon, said ribs being diagonally opposite 15 each other and substantially under the edges of the rail base, said tie plate also provided with spike holes arranged diagonally opposite to each other and to the ribs, substantially as described. 20

In testimony whereof I sign this specification in the presence of two witnesses.

DAVID SERVIS.

Witnesses:

W. H. CHAMBERLIN,
THOS. G. GRIER.