

(12) PATENT
(19) AUSTRALIAN PATENT OFFICE

(11) Application No. AU 199667067 B2
(10) Patent No. 720464

(54) Title
Programme selection means in a programme transmission and reception system

(51)⁷ International Patent Classification(s)
H04H 001/02

(21) Application No: **199667067**

(22) Application Date: **1996.08.09**

(87) WIPO No: **WO97/06613**

(30) Priority Data

(31) Number	(32) Date	(33) Country
95305539	1995.08.09	EP

(43) Publication Date : **1997.03.05**

(43) Publication Journal Date : **1997.05.01**

(44) Accepted Journal Date : **2000.06.01**

(71) Applicant(s)
British Telecommunications Public Limited Company

(72) Inventor(s)
Donald Fisk

(74) Agent/Attorney
BALDWIN SHELSTON WATERS,Level 21,60 Margaret Street,SYDNEY NSW 2000

(56) Related Art
GB 2263035
GB 2256546
GB 2256549



INT

<p>(51) International Patent Classification ⁶ : H04H 1/02</p>	<p>A2</p>	<p>(11) International Publication Number: WO 97/06613 (43) International Publication Date: 20 February 1997 (20.02.97)</p>
<p>(21) International Application Number: PCT/GB96/01944 (22) International Filing Date: 9 August 1996 (09.08.96) (30) Priority Data: 95305539.9 9 August 1995 (09.08.95) EP (34) Countries for which the regional or international application was filed: GB et al. (71) Applicant (for all designated States except US): BRITISH TELECOMMUNICATIONS PUBLIC LIMITED COMPANY [GB/GB]; 81 Newgate Street, London EC1A 7AJ (GB). (72) Inventor; and (75) Inventor/Applicant (for US only): FISK, Donald [GB/GB]; 25 Windrush Road, Kesgrave, Ipswich, Suffolk IP5 7NZ (GB). (74) Agent: DUTTON, Erica, Lindley, Graham; BT Group Legal Services, Intellectual Property Dept., 8th floor, 120 Holborn, London EC1N 2TE (GB).</p>		<p>(81) Designated States: AL, AM, AT, AU, AZ, BB, BG, BR, BY, CA, CH, CN, CU, CZ, DE, DK, EE, ES, FI, GB, GE, HU, IL, IS, JP, KE, KG, KP, KR, KZ, LK, LR, LS, LT, LU, LV, MD, MG, MK, MN, MW, MX, NO, NZ, PL, PT, RO, RU, SD, SE, SG, SI, SK, TJ, TM, TR, TT, UA, UG, US, UZ, VN, ARIPO patent (KE, LS, MW, SD, SZ, UG), Eurasian patent (AM, AZ, BY, KG, KZ, MD, RU, TJ, TM), European patent (AT, BE, CH, DE, DK, ES, FI, FR, GB, GR, IE, IT, LU, MC, NL, PT, SE), OAPI patent (BF, BJ, CF, CG, CI, CM, GA, GN, ML, MR, NE, SN, TD, TG).</p> <p>Published Without international search report and to be republished upon receipt of that report.</p>

(54) Title: PROGRAMME SELECTION MEANS IN A PROGRAMME TRANSMISSION AND RECEPTION SYSTEM

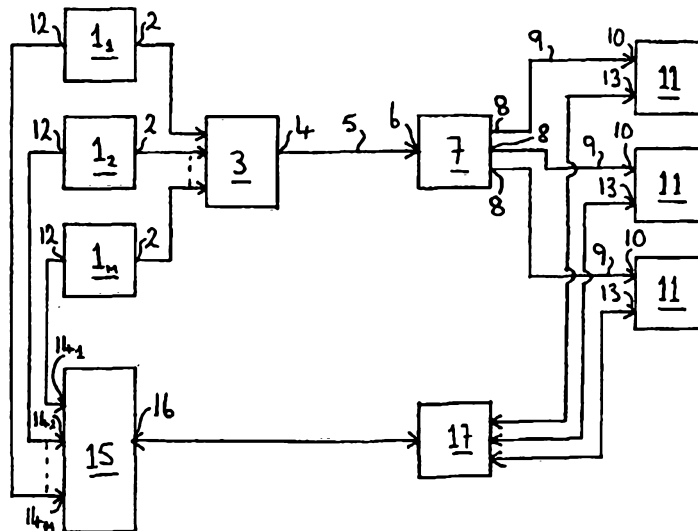

(57) Abstract

A multichoice programme transmission and reception system comprises a plurality of programme sources (1) coupled to a plurality of receivers (11) via a transmission path (3, 5, 7, 9). Further outputs (12) of the sources (1) supply identifications of the programmes they are currently transmitting to a processor (15). The processor (15) includes a database of the ratings users of the receivers (11) have previously given to various programmes, and the processor (15) uses these to estimate the order of preference which the user of each receiver (11) has for the programmes currently being transmitted. The processor (15) sends the corresponding order of the sources (1) to a data input (13) of the relevant receiver (11), and the receiver (11) responds by adjusting the mapping between specific actuations of its channel selector and the sources selected by these actuations to accord with the received order of sources, thereby facilitating selection by the user from a large number of available programmes.

SIGNAL RECEPTION SYSTEM

This invention relates to a multichoice reception system for signal transmissions, such as a reception system for multichoice television channels.

5 Radio and television broadcast reception systems are well-known. A receiver can be tuned by a user so as to select a particular broadcast programme at any given time. In order to make the tuning process easier, modern radio and television receivers are often provided with so-called "presets", which may take the form of respective keys provided on the receiver itself or on a remote control
10 unit therefor, which keys, upon actuation, tune the receiver to respective broadcast frequencies which are preprogrammed by a user. More sophisticated arrangements of keys may be provided in order to allow the receiver to be tuned to a large number of frequencies without requiring the provision of a corresponding number of keys. For example ten keys numbered zero to nine, plus
15 an "enter" key, allow any number between zero and 99 or even higher to be entered, and it can be arranged that keying in any of these numbers or "channels" results in the receiver being tuned to a respective broadcast frequency which has been preprogrammed by a user to correspond with that number or channel. As another example a single key or pair of keys may be provided, successive "and/or"
20 prolonged actuations of which step the tuning through a preprogrammed sequence of broadcast frequencies, either in one direction for a single key or in opposite directions in the case of respective keys of a pair of keys. As yet another example the presets may be voice-actuated, the receiver or remote control unit being capable in such a case of recognising simple spoken commands
25 such as "up", "down", "one", "two", "three" etc.

Because, inter alia, of insufficient bandwidth in the electromagnetic spectrum to accommodate present-day demand for concurrent broadcasts there is increasing interest in using cable and the like as the transmission medium between programme sources and receivers. A fibre-optic cable, for example, is
30 capable of carrying several hundred television programmes simultaneously. Availability of such a large number of programmes for reproduction by a receiver does, however, create selection problems for a user of the receiver; so-called "channel surfing"



becomes impracticable, or at least hit-and-miss, and perusal of complete programme listings becomes a major undertaking.

UK patent application GB-A-2 263 035 (Thomson Consumer electronics inc) describes a video cassette recorder (VCR) which includes apparatus for
5 controlling a cable TV converter unit: the objective being to make it easier for users to program their VCR. In particular, the problem of VCR programming for cable TV subscribers is addressed. The application acknowledges the programming simplification system referred to as VCR PLUS™ but suggests that this is rendered less useful for cable TV subscribers as they receive broadcast TV
10 channels over cable TV channels, and hence there is not necessarily any universal correspondence between the channel number assigned to a broadcast TV channel and that allocated to the cable TV channel which carries that broadcast channel. Reference is made to a VCR which includes VCR PLUS™ and an autoprogramming capability: "the channel mapping facility may be greatly simplified by using the
15 autoprogramming features to locate and program all active channels, and then by mapping in a channel guide list only those channels which are active, instead of requiring the user to select all 125 possible channel programming positions."

A further, earlier development concerning channel mapping is acknowledged in GB-A-2 263 035 as follows "when a user has access to a cable
20 system, via a cable box, and to the cable system directly, the VCR PLUS™ channel mapping feature may be automatically performed for premium channels from the cable box, thus simplifying the programming even more. Unfortunately even with this system, programs from two different premium systems cannot be recorded in sequence because that VCR cannot cause a channel change in the cable converter
25 box." It is noted in GB-A-2 263 035 that so-called premium programmes are typically encrypted and the cable box decrypts the signal and converts its RF carrier from its assigned channel frequency to a cable box out frequency. So it is clear that this system, which cannot change the cable converter box to detect a different channel can, for a premium channel which is received by the box in
30 encrypted form, only provide a useful (ie decrypted) recording of the channel if the cable box has already been set to the relevant premium channel.

European patent application EP A O 424 648 (General Instrument Company) describes a television distribution system in which alternative



"channels" of commercials are provided for insertion into the commercial breaks of the programming, the particular advertisements selected for transmission being determined (typically by the set top box in a cable TV system) on the basis of the personal demographics of the viewer(s). The viewer may be called upon to specify
5 demographic details (sex, age, etc) or the viewer's apparatus may be programmed with the relevant information on installation. At least where the user enters personal specifics (age or age group and sex) it is possible for the advertising to be very closely targeted at the likely interests of the viewer.

According to the present invention, there is provided a reception system
10 for selecting and receiving a signal, which signal has been selected from a set of signals, at least some of the set of signals having different respective signal content, the system comprising:

- i) a receiver for receiving a selected signal;
 - ii) user-actuable selection means for selecting, from the set of signals, a
15 signal to be received; and
 - iii) mapping means for mapping between the selection means and a signal selected thereby from the set
- wherein the mapping between specific actuations of the selection means and the actual signals selected is adjustable and the system is provided with mapping
20 adjustment means which adjusts the mapping between specific actuations of the selection means and the signal selected thereby, in accordance with the content of the respective signals.

The signals need to be distinguishable, so that the selection means can differentiate between them. They do not need though to be of a particular type.
25 For instance, the signals might be digital in which case they might for instance be distinguishable by containing different respective identifying sequences. Alternatively, the signals might be analogue in which case they might be distinguishable for instance by having different respective carrier frequencies. The signals might be transmitted from the same source, or from different respective
30 sources.

For example, the receiver could be a television receiver, provided with keys which allow the user to enter specific channel numbers. The correspondence



between these channel numbers and the transmissions which are selected when these numbers are entered can then be adjusted, according to an embodiment of the present invention, by the mapping adjustment means.

In a preferred embodiment, the adjustment could be performed so as to conform with expressed or estimated preferences of the user for programmes being transmitted. The user may, for example, have pre-notified an operator of a system according to an embodiment of the present invention that normally his first

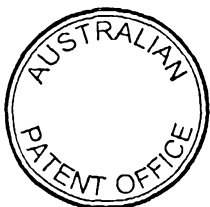

preference is for programmes of a first category, for example films, his second preference is for programmes of a second category, for example news programmes, and so on. If this is the case the mapping adjustment means may be arranged to adjust the mapping automatically in such a way that, at any given time while the receiver is operating, the individual programmes of the first category can be selected by entering the numbers 1 to N, where N is the number of programmes of the first category currently being transmitted, the individual programmes of the second category can be selected by entering the numbers N + 1 to N + M, where M is the number of programmes of the second category currently being transmitted, and so on. As an alternative in such a case, if the receiver is provided with a key prolonged or repeated actuations of which cause the receiver to reproduce currently available programmes in sequence, the mapping adjustment means may be arranged to automatically adjust the mapping in such a way that the individual programmes of the first category are selected first in the sequence, then the individual programmes of the second category, and so on.

Preferably the mapping adjustment means are arranged, in operation, to estimate automatically the preferences of a user of the receiver in respect of the currently available programmes and adjust the mapping in accordance with the results of the estimation. If this is the case it can be arranged, for example, that when the user selects channel "1" the receiver reproduces the programme which it is estimated will be his first choice of those currently being transmitted, when he selects channel "2" the receiver will reproduce his estimated second choice, and so on. An analogous possibility exists with respect to prolonged or repeated actuation of a single key.

Unless the context requires otherwise, throughout the specification and claims which follow, the word "comprise" and variations thereof, such as, "comprises" and "comprising" are to be construed in an inclusive sense, that is as "including, but not limited to".

An embodiment of the invention will now be described, by way of example only, with reference to the accompanying diagrammatic drawings, in which:

Figure 1 is a block diagram of a multichoice television programme transmission and reception system;

Figure 2 is a block diagram of a receiver included in the system of Figure 1; and

Figure 3 is a flow diagram of various operations carried out in the system of

Figure 1.

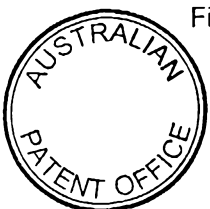

In Figure 1 a multichoice programme transmission and reception system comprises M sources $1_1, 1_2, \dots, 1_m$ of respective concurrent programmes where M may be, for example, several hundred. The sources 1 may comprise, for example, video or audio tape or disc playback machines, receivers for respective broadcast television or radio programmes, etc. First outputs 2 of the sources 1, which outputs carry the respective programmes, are coupled to respective inputs of a multiplexer 3, for example of the frequency-division or time-division type. The output 4 of multiplexer 3 is connected to a trunk cable 5, for example a fibre-optic cable. Trunk cable 5 feeds in turn the input 6 of a splitter 7 outputs 8 of which feed local drop cables 9 which again may be of the fibre-optic type. The cables 9 couple the splitter 7 to first inputs 10 of respective subscriber's receivers 11 which are each capable of selecting a programme from one of the sources 1 and reproducing that programme.

The part of the system of Figure 1 described so far is conventional. However, in contradistinction to known systems the sources 1 have respective data outputs 12 and the receivers 11 have respective data input/outputs 13. The data outputs 12 are coupled to respective inputs $14_1, 14_2, \dots, 14_m$ of a data processor 15 and the data input/outputs 13 are coupled to an output/input 16 of processor 15 via a multiplexer/demultiplexer 17. The multiplexer/demultiplexer 17 and the couplings between it and the receivers 11 and the processor 15 may for example be constituted by part of a public switched communications network. As an alternative, data communications between the output/input 16 of processor 15 and the input/outputs 13 of receivers 11 may for example be achieved via the trunk cable 5 and the respective local drop cables 9 if they, the splitter 7 and the multiplexer 3 are made bi-directional, and an input/output is provided on multiplexer 3 coupled to the output/input 16 of processor 15. In the latter case the multiplexer/demultiplexer 17 together with the couplings between it and the receivers 11 and the processor 15 may, of course, be omitted.

Figure 2 is a block diagram of each receiver 11 of Figure 1. The receiver 11 comprises in known manner a controllable selector 18 for selecting any one of the programmes supplied to the input 10 from the sources 1 of Figure 1 and passing it on to the input 19 of programme reproduction means 20. Reproduction means 20 may, for example, comprise an audio amplifier and loudspeakers if the

programmes supplied to input 10 are audio programmes, or a video amplifier, a display device and circuitry for controlling the display device if the programmes supplied to input 10 are video programmes.

A control input 21 of selector 18 is fed with control signals from an output
5 22 of a suitably programmed micro-processor 23, the control signals determining which programme is selected by selector 18 and passed on to reproduction means 20. A key-pad 24 which enables a user to enter channel numbers has its output coupled to an input 25 of microprocessor 23. Each time a channel number is entered by a user into key-pad 24 while the receiver is operating, microprocessor
10 23 responds by generating a digital code on its output 22, which code causes the selector 18 to select a specific one of the programmes fed to input 10.

A memory 26 is connected to an input/output 27 of microprocessor 23 and the receiver on/off switch 28 has an output 29 connected to an input 30 of microprocessor 23.

15 Conventionally there would be a fixed one-to-one relationship between the channel numbers entered into key-pad 24 and the digital codes generated at the microprocessor output 22 in response, these codes being stored in corresponding locations in a portion 26A of the memory 26. Upon a given channel number being entered into key-pad 24 microprocessor 23 would respond by accessing the
20 location in memory portion 26A corresponding to that number and read out the contents onto the output 22. However, in the receiver 11 being described this is not necessarily the case; a look-up table is stored in a portion 26B of memory 26. When operational this look-up table (which is reprogrammable) translates in an adjustable manner the channel numbers entered into key-pad 24 into addresses of
25 respective ones of the locations in the memory portion 26A. More specifically, when a channel number is entered into key-pad 24, microprocessor 23 responds by accessing a location in memory portion 26B which is assigned to that channel number and reads out the contents of that location. These contents constitute the address of a location in memory portion 26A and microprocessor 23 uses these
30 contents to address that location and read out its contents onto its output 22. Thus which programmes are selected by selector 18 in response to the entering of the various channel numbers into key-pad 24, i.e. the mapping of the channel numbers to the programmes, is, unless this feature is disabled, determined by the

look-up table in memory portion 26B. These contents can be and are changed in operation in response to data supplied to receiver input 13 by the processor 15 of Figure 1, these changes potentially occurring upon switch-on of the receiver 11 and subsequently each time a programme supplied to input 10 ends and another
5 begins, until the receiver is finally switched off again.

More specifically, the microprocessor is programmed to dispatch first and second specific signals on input/output 13 to the processor 15 of Figure 1 each time the receiver 11 is switched on and is subsequently switched off respectively, signals being supplied at these times to input 30 from on/off switch 28. These
10 specific signals each identify the receiver 11 from which the signal has come.

Processor 15 uses these signals to maintain in storage a list of all the receivers 11 which are currently operational. Processor 15 is furthermore supplied on its inputs 14 with information from the sources 1. This information is supplied from any source 1 each time that source commences transmission of its next
15 programme, and identifies that programme. Processor 15 responds to reception of each such item of information by storing it in memory at a location assigned to the relevant source 1, overwriting any such information from that source which has been previously stored. Thus at any given time processor 15 also has in storage a complete record of the programmes being transmitted by the respective sources 1.

Processor 15 responds to reception of an aforementioned first specific
20 signal from a receiver 11 by generating an order of preference which it is estimated the user of that receiver will have for all the programmes currently being transmitted by the sources 1. (A manner in which this can be done will be described below). Having done this processor 15 sends a message to the input 13
25 of the relevant receiver 11 identifying this order of preference in terms of the particular sources 1 which are transmitting the relevant programmes. The microprocessor 23 in the relevant receiver 11 responds to such a message by reprogramming the look-up table in memory portion 26B in such manner that, for example, a "1" entered into keypad 24 results in selector 18 selecting the
30 transmission from that source 1 which is transmitting the programme for which it has been estimated the user will have highest preference, a "2" entered into keypad 24 results in selector 18 selecting the transmission from that source 1 which is transmitting the programme for which it has been estimated the user will

have second-highest preference, and so on. Thus, unless he disables this facility, the user of the relevant receiver 11 can access in turn the current programmes which it has been estimated he will prefer, in decreasing order of estimated preference, simply by entering the channel numbers one, two, three in
5 succession into the keypad 24.

As mentioned previously, the processor 15 of Figure 1 receives a signal from each source 1 each time that source commences transmission of a new programme, the signal identifying that programme. Each time this occurs, in addition to updating its record of which programmes are being transmitted by
10 which sources 1, processor 15 recalculates the estimated orders of preference for the users of all the receivers 11 which are currently operational and transmits the results to the respective receivers via their inputs 13. The microprocessors 23 in the relevant receivers respond to reception of these new orders of preference in the same way as they did to the order of preference received upon switch-on, i.e.
15 by reprogramming the look-up table in the corresponding memory portion 26B to accord with the new order of preference. This periodic updating of the look-up table in each operational receiver continues until the relevant receiver is subsequently switched off, i.e. sends an aforesaid second specific signal to the processor 15.

20 It will be appreciated that it is not essential that the processor 15 calculates, or at least dispatches, a complete order of preference each time; it may be arranged to identify just the top few estimated preferences, out of a total number of programmes which is much more than this, and send these to each operating receiver 11. Furthermore it is not essential that each and every receiver
25 11 is supplied with, and utilises, the estimated order of preference information while it is in operation; it may be, for example, that this information is supplied only to receivers the users of which are subscribers to such a service. Furthermore it is not essential that the processor 15 takes into account all the programmes transmitted by the sources 1 when it estimates the orders of
30 preference in respect of each operating receiver 11; it may take into account merely a selected category or categories of programmes, e.g. films, serials, news programmes, etc, etc.

A method by which the processor 15 may estimate the preferences of the respective users for the currently-transmitted programmes will now be described. This method is particularly but not exclusively applicable to the estimation of orders of preference within a particular category of programme such as film, and
5 relies on the processor 15 having information about the ratings which have been given to respective ones of these programmes, and to other programmes, by people in the past, and about the ratings which have been given in the past to at least some of the other programmes by the users of the receivers 11. When such a method is employed a database of this information is maintained in memory in
10 the processor 15 or elsewhere in such a way that the ratings given to various programmes by the same person can be identified as such. These ratings may be obtained, and the database increased, by for example requesting each user of the system to rate each programme he has just watched on a scale of, say, 1 to 10 and send this rating together with the identities of both the programme and himself
15 to the processor 15 via the data output 13 of his receiver 11. If, for example, the preference estimation is limited to films then, on the assumption that most films are transmitted more than once, the database will eventually contain ratings on most of those currently being transmitted. As far as films which have not been previously rated are concerned these may merely be automatically included in, or
20 excluded from, a short list of estimated preferences for a given user in accordance with instructions he has previously given.

Figure 3 is a flow diagram of the various operations carried out by processor 15 of Figure 1 when such a method is employed, in response to the switching on of any receiver 11 and, in respect of each and every operating
25 receiver 11, in response to the start of transmission of a new programme by any of the sources 1. In Figure 3 the various blocks etc have the following significances.

31 - Start

32 - Set the identification number s of the source 1 whose currently
30 transmitted programme is to be rated for the user i of the receiver 11 under consideration to unity .

33 - Has the user i already rated the programme k_s currently being transmitted by source s ?

- 34 - For each other programme, calculate the correlation between the ratings (if any) other people have given this programme and the ratings (if any) the same people have given the programme k_s .
- 35 - Determine the N programmes the ratings of which exhibit the highest
5 correlation, as calculated in 34, with the ratings of programme k_s .
- 36 - For each of the other people determine the equation of the straight line which best fits the set of points which would be obtained by plotting the rating given by user i to each of the N programmes against the rating (if any) given to the same programme by that other person.
- 10 37 - For each of the other people calculate, using the corresponding equation determined in 36, the equivalent rating for user i to the rating (if any) given to the programme k_s by that other person.
- 38 - For each of the other people calculate the correlation between the rating (if any) he has given to each of the N programmes and the rating which user i has
15 given to the same programme.
- 39 - Determine the equation of the straight line which best fits the set of points which would be obtained by plotting each equivalent rating calculated in 37 against the correlation calculated in 38 for the person from whose rating that equivalent rating has been calculated.
- 20 40 - Calculate from the equation determined in 39 the equivalent rating which corresponds to a correlation of
+ 1.
- 41 - Store the equivalent rating calculated in 40 as the estimated rating by user i of the programme k_s currently being transmitted by source s.
- 25 42 - Is s equal to M, the total number of sources 1?
43 - Increment s by unity.
44 - Order the sources 1 in terms of the corresponding estimated ratings stored in the steps 41.
45 - Transmit the order of the sources 1 obtained in 44 to the receiver 11
30 whose user is user i.
46 - End.

Test 42 and steps 32 and 43 merely ensure that an estimated rating for user i is calculated for each of the programmes currently being transmitted by the

sources 1, with the exception of any programmes he has previously rated. (It is assumed that user i will not wish to experience again any programme he has previously rated. Of course the opposite assumption could alternatively be made, in which case the path from the "yes" (Y) output of test 33 to test 42 should
5 include the further step of storing user i 's previous rating as the estimated rating for the programme currently being transmitted by the relevant source s).

Steps 34 to 36 serve to determine "best-fit" linear equations for converting ratings given to programmes by other people into equivalent ratings by user i . Steps 34 and 35 serve to ensure that the data used in the actual
10 determination in step 36, i.e. ratings previously given to specific programmes by both user i and other people, is that which is likely to give the most accurate result when the equation is used to convert the ratings previously given by the other people to the programme k_s into an equivalent rating by user i . More specifically the data is chosen to be that which relates to the N programmes whose ratings by
15 the other people are most closely correlated with the ratings they have given to the programme k_s . In practice this normally means that N programmes are selected which are of the same genre as programme k_s or are similar in other ways, e.g. appeal to the same age group.

Determination of a linear (or non-linear) equation which best fits a
20 collection of points is, of course, a well known mathematical technique.

Having determined the "best-fit" equations in step 36 for each of the other people these equations are then used in step 37 to convert the individual ratings of the programme k_s by the corresponding other people into equivalent ratings by user i .

25 A further "best-fit" linear equation is then determined in steps 38 and 39, this time for converting the equivalent ratings obtained in step 37 into an overall estimated rating for the user i .

This conversion is done in such a way as to take into account, for each person whose rating of the programme k_s has given rise to an equivalent rating in
30 step 37, the correlation between the ratings he has given the N other programmes and the ratings user i has given the same programmes. Accordingly the relevant correlations are calculated in step 38 and the further best-fit equation is determined in step 39 as being that of the straight line which best fits the set of

points which would be obtained by plotting the equivalent ratings against the correlations calculated for the people from whose ratings the equivalent ratings have been derived. The estimated rating is then calculated from the further best-fit equation in step 40 as being the equivalent rating corresponding to a correlation of
5 + 1.

It will be appreciated that it is not essential that the "best-fit" equations determined in steps 36 and 39 are linear equations; they can be higher-order equations if desired. However it has been found that linear equations can give satisfactory results and their determination, of course, requires less processing
10 than would be required for the determination of higher-order equations.

After the estimated ratings by user i of the programmes currently being transmitted by all the sources 1 have been calculated and stored (output from test 42 "yes" (Y)), the sources 1 are ordered in step 44 in terms of the corresponding estimated ratings and this order is transmitted to the receiver 11 of the user i in
15 step 45. Once this has been done the estimated ratings for the user of another receiver 11 can be calculated and the sources 1 ordered in accordance therewith, and so on for the user of each receiver 11 in succession. Alternatively the estimated ratings for the users of several receivers can be calculated, and the sources correspondingly ordered, in parallel with each other.

20 As indicated above, the processors 23 in the various receivers 11 are programmed to respond to reception by the relevant receiver of an order of sources 1 from the processor 15 by reprogramming the look-up table in the corresponding memory portion 26B. This look-up table contains a memory location corresponding to each channel number keyed into key-pad 24, whereas memory portion 26A
25 contains a memory location corresponding to each source 1. Upon reception by the relevant receiver of an order of sources 1 the microprocessor 23 responds by writing the addresses of the various locations in memory portion 26A into respective locations in the memory portion 26B so as to produce a mapping between the various channel numbers and the various sources which corresponds
30 to the received order of sources.

Also as indicated above a facility may be provided in each receiver 11 for disabling/enabling the reprogramming of the look-up table. This may be arranged to occur, for example, in response to the entering of specific codes into the key-

pad 24, and disabling may be arranged to result in the creation of a predetermined fixed mapping between the channel numbers and the sources, which mapping is maintained until the reprogramming is subsequently enabled once again.

If desired each microprocessor 23 may be programmed to cause the
5 programme for which it is estimated the user of the relevant receiver currently has the highest preference to be automatically selected upon switch-on of the receiver.

It will be appreciated that many modifications may be made to the system described, within the scope of the invention as defined by the claims. For example, it is not essential that the processing for all the receivers 11 is carried
10 out by a single processor 15 remote from these receivers; the processing for each receiver may be carried out within that receiver provided of course that the receiver receives on an on-going basis from all the sources 1 information identifying the programmes they are currently transmitting.

CLAIMS

1. A reception system for selecting and receiving a signal, which signal has been selected from a set of signals, at least some of the set of signals having
5 different respective signal content, the system comprising:
- i) a receiver for receiving a selected signal;
 - ii) user-actuable selection means for selecting, from the set of signals, a signal to be received; and
 - iii) mapping means for mapping between the selection means and a signal
10 selected thereby from the set,
- wherein the mapping between specific actuations of the selection means and the actual signals selected is adjustable and the system is provided with mapping adjustment means which adjusts the mapping between specific actuations of the selection means and the signal selected thereby, in accordance with the content
15 of the respective signals, the adjustment means controlling and adjusting the mapping in response to changes in the content of respective signals.
2. A system as claimed in Claim 1, wherein the mapping adjustment means
20 is arranged, in operation, to estimate the preferences of a user of the receiver in respect of signals available for reception and to adjust said mapping in accordance with the result of the estimation.
3. A system as claimed in Claim 2, wherein the mapping adjustment means
25 is arranged, in operation, to estimate the relative ratings the user would give to a subject set of respective signals and to order these signals in terms of their estimated ratings.
4. A system as claimed in Claim 3, further comprising storage means storing
30 at least three data sets, these comprising
- i) ratings the user has given to a set of respective signals different from said subject set,



ii) ratings people other than the user have given to said set of respective signals different from said subject set, and

iii) ratings said people other than the user have given to said subject set,

5 wherein the mapping adjustment means is provided with a best fit analyser for deriving from data sets i) and ii), for respective ones of said people other than the user, a relationship between ratings given by the user and ratings given by said other person to said set of respective signals different from the subject set, and wherein the mapping adjustment means is further provided with data
10 processing means, for processing data set iii) according to the relationships to obtain for respective ratings in data set iii) an equivalent rating for the user, and for processing these equivalent ratings to obtain the estimated relative ratings for the user.

15 5. A system as claimed in Claim 4, wherein the mapping adjustment means is further provided with selection means having a correlator, for selecting said set of respective signals different from the subject set, the selection being based on the degree of correlation between the ratings of data sets i) and ii) for the selected set of respective signals different from the subject set.

20

6. A system as claimed in either one of claims 4 or 5, wherein the data processing means for processing data set iii) is arranged, in operation, to obtain the
estimated relative ratings for the user from equivalent ratings obtained by
25 processing data set iii) by calculating, for respective ones of the other people from whose rating in data set iii) a said equivalent rating has been derived, the correlation between the ratings for that person in data set ii) and the ratings for the user in data set i), deriving from the equivalent ratings and the calculated correlations a best-fit equation for converting these correlations into equivalent
30 ratings, and calculating the estimated rating for the user from said best-fit equation as being the equivalent rating corresponding to a correlation of +1.

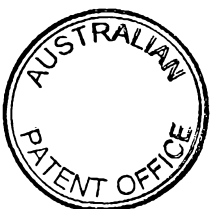

7. A system according to any one of the preceding claims wherein the signals comprise information for display.
8. A system according to any one of the preceding claims wherein the signals comprise television signals.
- 5 9. A system according to any one of the preceding claims wherein the signals comprise video signals.
- 10 10. A system according to any one of the preceding claims wherein the signals comprise audio signals.
11. A reception system substantially as hereinbefore described with reference to
10 the accompanying drawings.

DATED this 11th day of April, 2000

BRITISH TELECOMMUNICATIONS public limited company

Attorney: PETER R. HEATHCOTE
Fellow Institute of Patent Attorneys of Australia
of BALDWIN SHELSTON WATERS

15

15

15

15



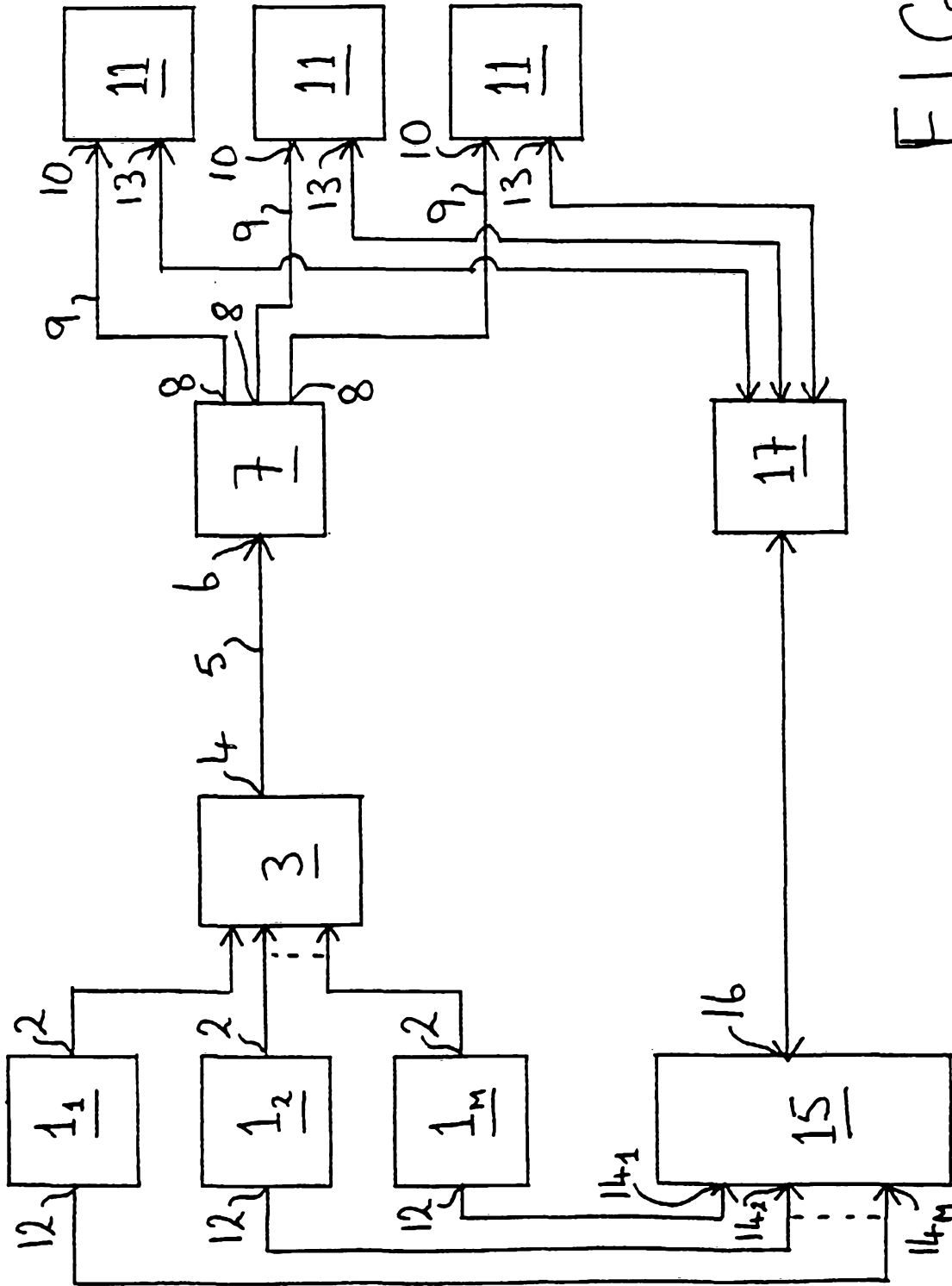

FIG. 1

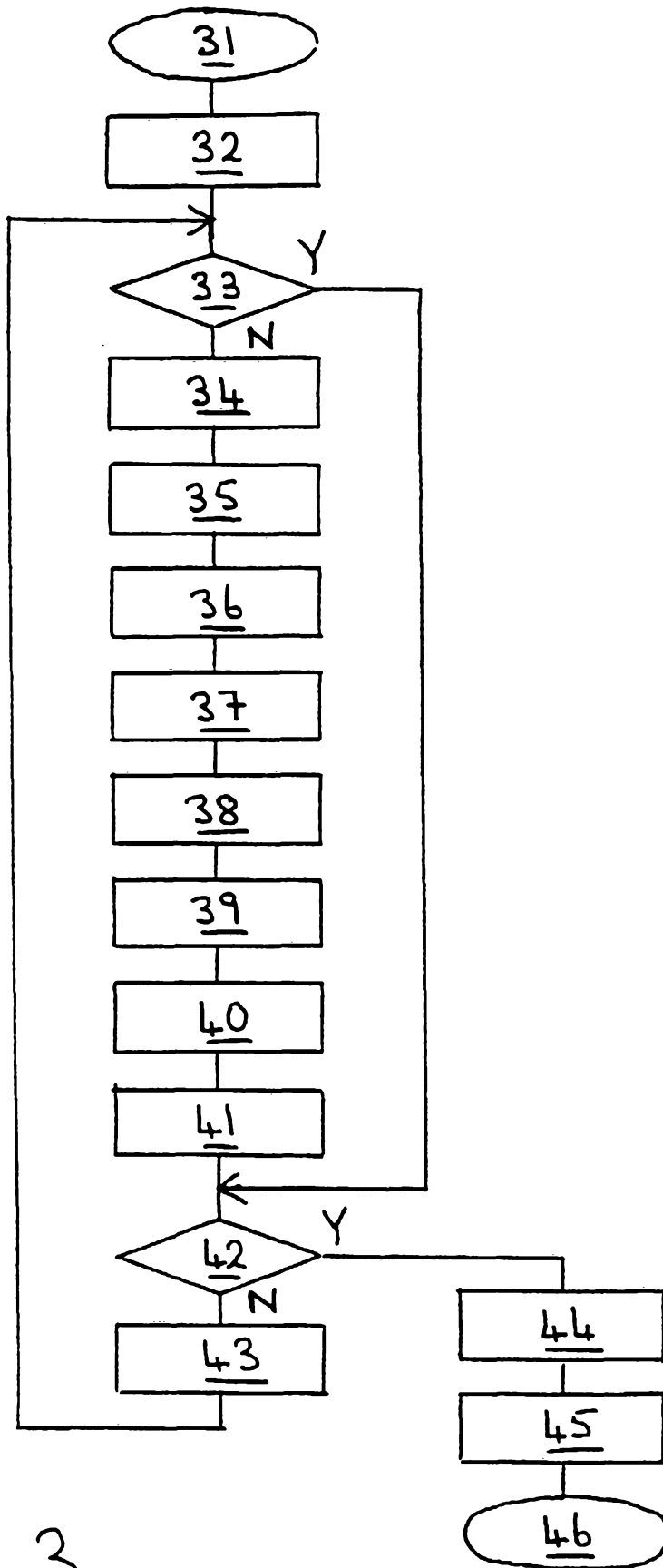

FIG. 3.