

March 9, 1948.

C. O. RASMÜSSEN

2,437,651

LAUNDRY CENTRIFUGAL

Filed Aug. 8, 1939

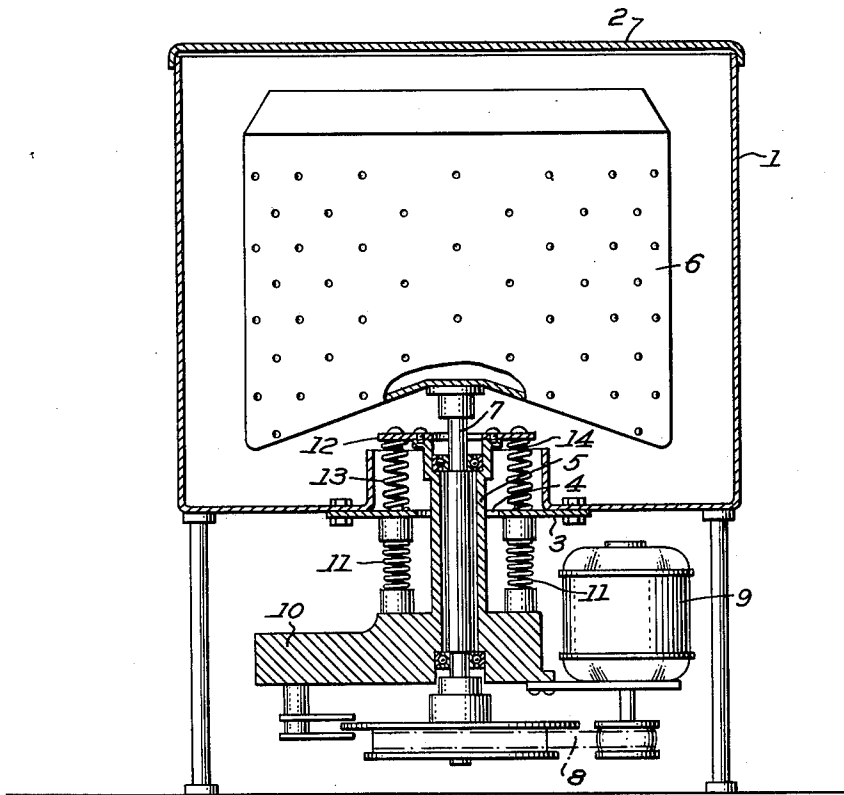

Inventor:

CHRISTIAN OSCAR RASMÜSSEN

By

Singer, Eklert, Stern & Carlberg

Attorneys.

UNITED STATES PATENT OFFICE

2,437,651

LAUNDRY CENTRIFUGAL

Christian Oscar Rasmussen, Copenhagen,
Denmark

Application August 8, 1939, Serial No. 289,081
In Denmark August 9, 1938

Section 3, Public Law 690, August 8, 1946
Patent expires August 9, 1958

2 Claims. (Cl. 210-71)

1

In laundry centrifugals, the centrifugal drum is practically always suspended resiliently, special springs being provided which serve to support the drum and the parts built together with the same, for instance the motor driving the drum, while other springs serve to stabilize the rotation of the drum, in such a manner that any lateral oscillations during the operation will be subdued and caused to cease quickly and effectively.

The centrifugal drum has thus been suspended resiliently at its shaft bearings in a tubular body passing through a hole in the bottom of the centrifugal casing and having an upper and a lower collar situated, respectively, above and below the bottom of the centrifugal casing and attached thereto by means of mainly vertical helical springs. Of such springs a number of mainly vertical compression springs disposed in a circular row about the centrifugal shaft have been used, or merely one compression spring encircling the centrifugal shaft co-axially and exerting, with an upper and a lower part, a pressure against the upper collar of the tubular body and the bottom of the centrifugal casing, respectively, and against the latter and the lower collar of the tubular body. The lower compression-spring part serves solely as a stabilizer, but owing to its pressure it will unavoidably increase the work to be performed by the upper solely drum-carrying compression-spring part in carrying the centrifugal drum and the driving motor of the same and the other power-transmitting parts which ordinarily, in order to improve the stability, are disposed below the bottom of the centrifugal casing. It has therefore been necessary to give the upper compression-spring part a rather considerable stiffness which especially in larger laundry centrifugals has had the consequence that the spring part, owing to the said circumstances, must be rendered so stiff that it cannot satisfactorily prevent the transmission of the vibrations from the rapidly rotating drum to the centrifugal casing and, thereby, to the surroundings.

The present invention has for its object to remedy this drawback in that the requirements as to the strength of the upper spring part or parts are reduced very considerably. According to the invention, this result is attained by the provision, between the bottom of the centrifugal casing and the lower collar, of a number of tension springs disposed in a circular row about the centrifugal shaft, while a number of compression springs, similarly arranged in a circular row, are provided between the bottom and

2

the upper collar. In consequence of this arrangement, the lower springs will not, as in the case of the known centrifugals, increase the load on the upper springs, but will, on the contrary, relieve this load, as all the springs will now assist in supporting the tubular body and the centrifugal drum journalled therein together with the driving motor and the power-transmitting members. The upper springs may therefore be made considerably softer, and thereby a transmission to the surroundings of the vibrations of the drum during the operation will be reduced, while similarly the life of the springs will be increased. All the springs may be firmly held at their ends, and thereby their stabilizing effect on the centrifugal during lateral oscillations of the same will be increased.

The drawing shows a vertical diametral section of a centrifugal constructed in accordance with the invention.

The centrifugal casing 1 is closed at the top by a cover 2, and has, at the bottom, a central hole which is partly covered by a bottom plate 3 which similarly has a central hole 4. Through this hole a tubular body 5 is inserted in the interior of which the shaft 7 of the centrifugal drum 6 is journalled in ball bearings, and the electro-motor 9 driving the drum by means of special driving members, such as pulleys 8, is disposed on a lower flange 10 on the body 5. Between this flange and the bottom plate 3, tension springs 11 are inserted, which are rigidly held at their ends and between the bottom plate 3 and the upper collar 12 on the tubular body 5 compression springs 13 are provided which similarly may be rigidly held at their ends, for instance as shown in that they encircle small cylindrical pins 14 on the collar 12 and the bottom part 3, respectively.

The springs 13, as well as the springs 11, are disposed in a circular row about the shaft of the drum 6, and all the springs serve to support the drum. Further, during any lateral oscillations of the drum during the operation, all the springs will assist in straightening the drum into a vertical position. The springs 11 are preferably disposed in such a manner that they are each co-axial to a corresponding spring 13, but this is no absolute condition for working the invention, and similarly the springs do not necessarily have to be disposed in the manner indicated above.

The helical springs may for instance be replaced by resilient members of a different nature, and similarly the hole 4 in the bottom part 3 may

3

be covered, on the inside, with felt or rubber, in order to support the body 5.

Having now described my invention, what I claim as new and desire to secure by Letters Patent is:

1. A laundry centrifugal comprising a casing having a bottom with a hole in it, a tubular body passing freely through said hole, said body having an upper collar within the casing and a lower collar below the casing, a set of helical compression springs of a relatively great resiliency secured to said upper collar and to said bottom and arranged in a circular row around said tubular body, a set of tension springs of a relatively small resiliency secured to said bottom and to said lower collar and arranged in a circular row around said tubular body, said tubular body constituting a shaft bearing and support, and a drum supporting shaft carried by and journaled in said tubular body.

4

2. A laundry centrifugal comprising a casing having a bottom with a hole, a drum carrying shaft projected through said hole, a tubular shaft supporting bearing member also projecting through said hole and carrying said shaft and its drum, and means for floatingly supporting said tubular member from said bottom, said means comprising a set of compression springs arranged in a circular row about said tubular member within the casing with the ends of the springs respectively connected to said bottom and with said tubular member and a second set of tension springs arranged in a circular row about said tubular member with their ends respectively connected to said bottom and with said tubular member at places below said bottom, the first set of springs being of relatively great resiliency acting and the second set being relatively stiff acting.

20

CHRISTIAN OSCAR RASMUSSEN.