

(19) **DANMARK**



Patent- og
Varemærkestyrelsen

(10) **DK/EP 2472021 T3**

(12) **Oversættelse af
europæisk patentskrift**

-
- (51) Int.Cl.: **E 04 B 2/96 (2006.01)**
- (45) Oversættelsen bekendtgjort den: **2016-05-30**
- (80) Dato for Den Europæiske Patentmyndigheds bekendtgørelse om meddelelse af patentet: **2016-03-02**
- (86) Europæisk ansøgning nr.: **10197260.2**
- (86) Europæisk indleveringsdag: **2010-12-29**
- (87) Den europæiske ansøgnings publiceringsdag: **2012-07-04**
- (84) Designerede stater: **AL AT BE BG CH CY CZ DE DK EE ES FI FR GB GR HR HU IE IS IT LI LT LU LV MC MK MT NL NO PL PT RO RS SE SI SK SM TR**
- (73) Patenthaver: **VKR Holding A/S, Breettevej 18, 2970 Hørsholm, Danmark**
- (72) Opfinder: **Rasmussen, Johnny Christian Nyggard, Hvedelunden 37, 8722 Hedensted, Danmark**
- (54) Benævnelse: **FREMGANGSMÅDE TIL FASTGØRELSE AF EN GENSTAND TIL ET TYNDVÆGGET GLASFIBERFORSTÆRKET PROFIL, DER ER FREMSTILLET VED PULTRUDERING, OG VINDUE MED ET SÅDANT PROFIL**
- (56) Fremdragne publikationer:
DE-U1-202005 005 795
DE-U1-202008 004 373
FR-A1- 2 624 157

DESCRIPTION

[0001] The present invention relates to a method for attachment of an object to a thin-walled fibre glass reinforced profile made by pultrusion according to the preamble of claim 1.

[0002] The invention also relates to a window according to the preamble of claim 4.

[0003] Fibre glass reinforced profiles are typically used as an alternative to profiles of aluminium. They have the advantage that they are relatively cheap and easy to manufacture and have smaller carbon footprints. At the same time they are highly resistant to moisture and heat, which makes them well suited for use in window frames and like applications. Reference is made to DE 20 2005 005 795 U1 or DE 20 2008 004 373 U1.

[0004] There is, however, one major problem, which have had a negative influence on the use of fibre glass reinforced profiles, namely that the high content of glass, which is typically 60-80%, makes it relatively difficult to cut and drill in them. The tools used are simply worn down and has to be sharpened or replaced very frequently and the idea of simply driving screws directly into the profiles fails for the same reason. Another problem related to the high fibre content is that the profiles tend to delaminate during reworking.

[0005] Gluing is of course an option, but, as is well-known to the skilled person, glue joints are not always sufficiently strong and reliable.

[0006] It is therefore the object of the invention to provide an alternative method for attachment of an objects to thin-walled fibre glass reinforced profiles made by pultrusion.

[0007] This object is achieved by a method according to claim 1, where the/each fastening member is driven into an open-ended space between two walls of the profile, where the opening faces an outer surface of the profile and where the space has a width corresponding substantially to the minor diameter of the thread, typically 2-20 mm. In the overall perspective the walls will be substantially parallel, but small variations are acceptable and variations in wall thickness may cause the inner and/or outer sides to be located at an angle to each other.

[0008] In this way the fastening member is clamped between the two walls, which, when seen in cross-section, form a pocket hole. The walls are forced slightly apart during insertion, and the thread, which penetrates into the surface of the two walls, serves as barbs preventing the fastening member from being pulled out again. The surface of the profile walls consist primarily of the matrix material, which is a polymer, typically polyurethane or polypropylene, and therefore does not degrade the thread of the fastening member to any considerable degree.

[0009] The clamping effect may be increased by using a profile, where the distance between the two walls varies and has a minimum at the space opening. According to the invention at least one of the walls is provided with a weakening zone at a distance from the opening allowing the wall, which may otherwise be relatively stiff, to bend. The distance from the opening to the weakening zone should ideally be slightly bigger than the length of the fastening member employed.

[0010] The fastening members are preferably screws, since the pointed end will ease the insertion into the opening between the walls, but bolts may also be employed. Moreover, nails or spikes having ridges around the circumference of their body may also be regarded as threaded within the meaning of the present application.

[0011] When the fastening member is of a configuration having a head and an elongate body carrying the thread, such as a screw or bolt, it is preferred that, in the mounted state, the body is positioned entirely in the space between the two walls, while at least a part of the head is outside the space.

[0012] Over time the presence of the fastening member combined with relaxation in the matrix material can cause the two walls to move slightly away from each other, which may cause the fastening member to become loose. To avoid this, it is essential to apply a retaining member keeping the two walls in place. When the ends of the two walls are substantially at the same level, the retaining may simply be a metal bracket spanning over both of them. When the profile is used for a window frame or sash, care should, however, be taken that the retaining member does not form an undesirable thermal bridge.

[0013] In order to provide an even better attachment, a filler or glue can be introduced into the space before the fastening members. This filler or glue will contribute to fixating the fastening member, not only with regards to movement out of the space,

but also against movement in the length direction of the profile. A filler or glue may also function as a lubricant during insertion of the fastening member.

[0014] In the following, the invention will be described with reference to the drawing in which Fig. 1 shows a cross-sectional view of two windows 1a, 1b mounted side-by-side. The panes 2a, 2b of the windows are kept in place by means of glazing lists 3a, 3b, which are attached to the sash members 4a, 4b by means of screws 5a, 5b according to an embodiment of the invention.

[0015] Whenever a reference number is used, which does not include an a or b, this is to be understood as an indication, that reference is made to the particular feature in general and that there is no substantial difference between the two windows.

[0016] The screw 5, which is used as fastening member in this embodiment, is located in a pocket hole, which is formed by two walls 6,7 of the profile constituting the sash 4 and is open towards an outer side of the profile. On the left-hand side the length of the screw 5a corresponds to the depth of the hole and on the right-hand side the screw 5b is somewhat shorter.

[0017] The distance between the walls 6,7 corresponds to the minor diameter of the thread of the screw, meaning that the thread cuts into the interior side surfaces of the walls and that a clamping effect is achieved where the walls presses on the sides of the screw.

[0018] In the embodiment shown, the walls 6,7 are parallel and with straight interior sides, but this need not be the case. An improved clamping effect may be achieved by arranging the walls in a slightly angle position in relation to each other so that the distance between them is smallest at the opening or by providing a local projection at the opening. Alternatively, if using tapered screws the walls may be arranged at an angle to each other so that the shape of the space between them corresponds to the shape of the screw. These variations in angle may be achieved by making the walls with non-constant thickness. Finally, giving the walls a profiled surface may contribute to the attachment of the fastening member and possibly ease introduction of the fastening member.

[0019] At the bottom, the hole has a bulge 8 as may best be seen on the right-hand window. The bulge serves as a weakening zone and when the screw 5 is introduced into the hole, the walls bend slightly at this place, thereby easing the introduction. In this embodiment both walls have free ends, which allows them both to bend, but this need not be the case.

[0020] The bending of the walls 6,7 is an advantage during the initial introduction of the screw 5, but may subsequently result in the screw coming loose. To avoid this the glazing list 3 is designed with two legs 9, 10, which, in the mounted state, lies closely along the outer side of the walls 6,7. In this way the glazing list functions as a retaining member keeping the two legs from moving away from each other. This is considered an advantage since the retaining function is achieved without increasing the number of different components needed for the construction of the window, but separate members may of course also be employed.

[0021] When two windows are mounted side-by-side as shown in the drawing, a retaining function could also be achieved with a member arranged between the walls 7a,7b facing the opposite window. Such a member could be formed as a projection on one wall or both of these walls 7a,7b. This embodiment which does not form part of the invention is, however, not suited for windows with sashes that can be opened.

REFERENCES CITED IN THE DESCRIPTION

This list of references cited by the applicant is for the reader's convenience only. It does not form part of the European patent document. Even though great care has been taken in compiling the references, errors or omissions cannot be excluded and the EPO disclaims all liability in this regard.

Patent documents cited in the description

- [DE202005005795U1 \[0003\]](#)
- [DE202008004373U1 \[0003\]](#)

PATENTKRAV

1. Fremgangsmåde til fastgørelse af en glasliste (3, 3a, 3b) til et tyndvægget glasfiberforstærket profil (4, 4a, 4b), der er fremstillet ved pultrudering, med et antal vægge, hvor fastgørelsen opnås ved hjælp af ét eller flere gevindfastgørelseselementer (5, 5a, 5b), hvor et eller hvert fastgørelseselement skrues ind i et rum med åben ende mellem to vægge (6, 7, 6a, 6b, 7a, 7b) i profilet, hvor åbningen af rummet vender mod en ydre overflade af profilet, og hvor rummet har en bredde, der i alt væsentligt svarer til den mindste diameter af gevindet, kendetegnet ved, at glaslistens to ben (9, 10) er indrettet til at ligge tæt langs de tilsvarende ydre sider af de to vægge (6, 7, 6a, 6b, 7a, 7b), således at glaslisten fungerer som et holdelement, der holder de to vægge fra at bevæge sig væk fra hinanden, og ved, at mindst én af de to vægge (6, 7, 6a, 6b, 7a, 7b) er forsynet med et svækkelsesområde (8) i en afstand fra åbningen, som tillader at væggen kan bøjes.
2. Fremgangsmåde ifølge krav 1, hvor fastgørelseselementet (5, 5a, 5b) er en skrue eller bolt.
3. Fremgangsmåde ifølge et hvilket som helst af de foregående krav, hvor et fyldstof eller lim anbringes i rummet før indføring af fastgørelseselementet (5, 5a, 5b).
4. Vindue (1a, 1b) omfattende en rude (2a, 2b), en glasliste (3, 3a, 3b) og et tyndvægget glasfiberforstærket profil (4, 4a, 4b), der er fremstillet ved pultrudering, omfattende et antal vægge, hvor to vægge (6, 7, 6a, 6b, 7a, 7b) i alt væsentligt er parallelle og placeret i en afstand på 2-20 mm, hvor mindst én af disse vægge har en fri ende, således at der dannes et rum med en åben ende mellem dem, hvor åbningen af rummet vender mod en ydre overflade af profilet, hvor glaslisten er fastgjort til det tyndvæggede

- glasfiberforstærkede profil ved hjælp af ét eller flere gevindfastgørelseselementer (5, 5a, 5b), hvilket eller hvilke fastgørelseselementer skrues ind i et rum med åben ende mellem de to vægge, kendetegnet ved, at glaslistens to ben (9, 10) ligger tæt langs de tilsvarende ydre sider af de to vægge (6, 7, 6a, 6b, 7a, 7b), således at glaslisten fungerer som et holdelement, der holder de to vægge fra at bevæge sig væk fra hinanden, og ved, at mindst én af de to vægge (6, 7, 6a, 6b, 7a, 7b) er forsynet med et svækkelsesområde (8) i en afstand fra åbningen, som tillader at væggen kan bøjes.
- 5
- 10
5. Vindue ifølge krav 4, hvor afstanden mellem de to vægge (6, 7, 6a, 6b, 7a, 7b) varierer og har et minimum ved åbningen til rummet.
 6. Vindue ifølge et hvilket som helst af kravene 4 eller 5, hvor det tyndvæggede profil (4, 4a, 4b) er fremstillet af en plastmatrix, der er forstærket med glasfiber.
- 15

DRAWINGS

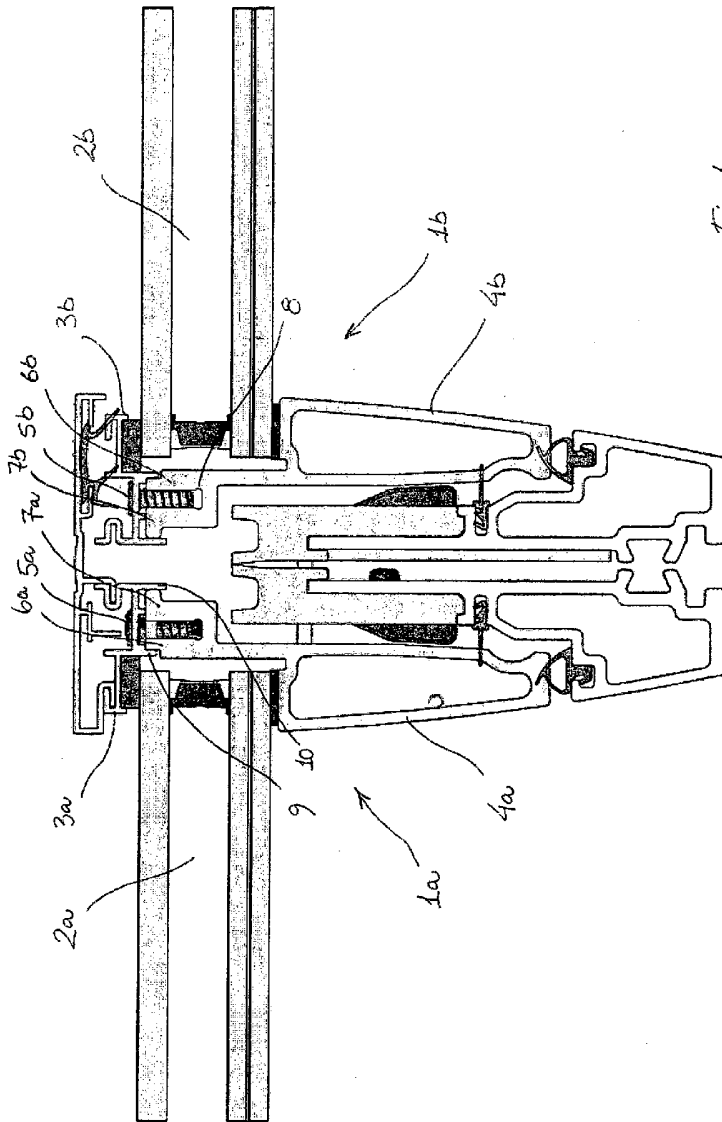

Fig. 1