

April 10, 1956

J. L. VIECELI

2,741,235

STARTER FOR INTERNAL COMBUSTION ENGINE

Filed Aug. 12, 1954

2 Sheets-Sheet 2

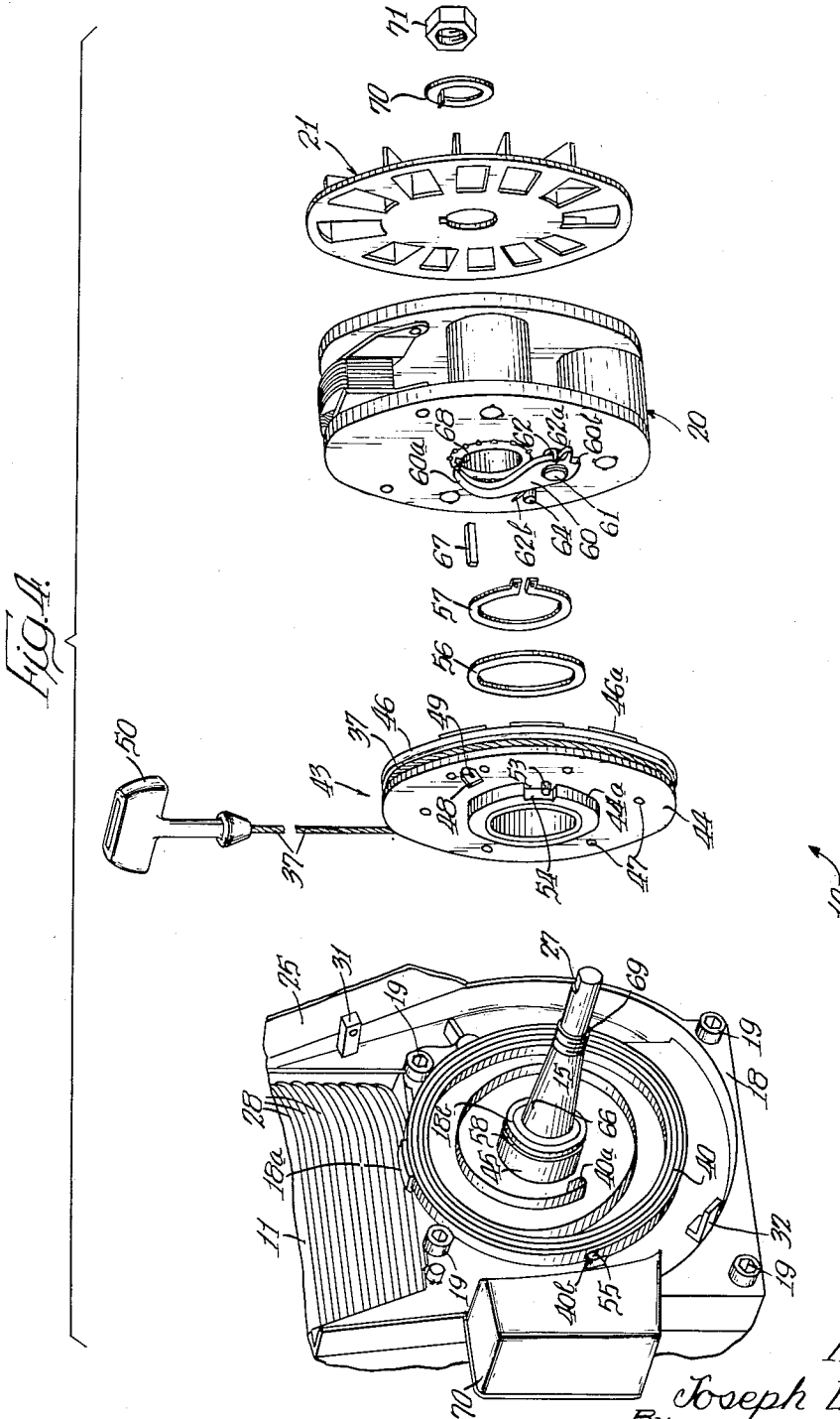

Inventor:
Joseph L. Vieceli
By: Mason, Kolchman, Rathbun & Wypa
Attys.

1

2,741,235

STARTER FOR INTERNAL COMBUSTION ENGINE

Joseph L. Vieceli, Cicero, Ill., assignor to Sunbeam Corporation, Chicago, Ill., a corporation of Illinois

Application August 12, 1954, Serial No. 449,479

10 Claims. (Cl. 123—185)

The present invention relates to a starter for an internal combustion engine, and, more particularly, to a mechanical starter for internal combustion engines of the type that are used for lawn mowers, outboard motors and the like. Internal combustion engines of the above-mentioned type are commonly started by using a starting cord or cable of some sort which is arranged so that upon pulling the starting cord rotation of the motor is produced, which rotation is sufficient to cause the same to start. Such starting devices have been provided with a rewind spring so that the starting cable is rewound upon a suitable reel after use so as to be ready for the next starting operation. It has been common practice with such starters employing a rewind spring to mount the starting mechanism on a shroud conventionally associated with such engines for enclosing the engine flywheel and perhaps also the engine fan. Where starting mechanisms are not employed, such shrouds may be formed of very light metal. However, when the starting mechanism is to be supported by the shroud, the latter must be made of strong and heavy material satisfactorily to support the starting mechanism. Consequently, it is not possible to employ the light fan and flywheel housing that could be employed if such a built-in starting mechanism were not involved, and the shroud cost is greatly increased. It would be desirable to provide a starter for internal combustion engines which does not require a heavy shroud or special support for supporting the same.

Heretofore it has been common practice to provide the starting mechanism for internal combustion engines as a sort of appendage to the engine. It would be desirable to provide an arrangement in which the starting mechanism is located where it will always remain clean so that dust and dirt are prevented from fouling up the same, and preferably so that it is housed in a completely protected space such as between the engine and the flywheel or the like. Obviously, with such a location it is desirable to maintain the over-all size of an internal combustion engine for use as the prime mover for lawn mowers and the like as small as possible, and such a starter must be capable of being disposed in a very small space.

The prior art mechanical starters for internal combustion engines have employed pawl mechanisms including a plurality of pawls which are biased into engagement with a ratchet so that upon pulling the starting cord or cable rotation of the engine crankshaft results. These pawls, moreover, are arranged so that when the motor operates and obtains a certain speed they move by centrifugal force to a nonengaging position as far as the ratchet is concerned. It has been common practice to provide complicated mechanisms to insure simultaneous operation of the plurality of pawls. It would be desirable to provide an arrangement in which such complicated mechanism can be completely dispensed with.

It will be appreciated that in connection with portable outboard motors, lawn mowers and the like weight is a very important factor as far as the motor is concerned. It is desirable to maintain the weight at a minimum. Accordingly, it is desirable to provide a starting mechanism

2

for such motors which comprises a minimum number of parts and which adds very little to the weight of the motor as well as very little to the size of the motor.

It is an object of the present invention to provide a starter for internal combustion engines that includes the desirable features enumerated above.

It is another object of the present invention to provide a mechanical starter for internal combustion engines which is a part of the engine itself, requiring a very small space, and disposed so that the engine itself forms a part of the housing therefor.

It is a further object of the present invention to provide a starter for internal combustion engines which is not a mere appendage to the engine, but which is an integral part thereof.

It is another object to provide an improved mechanical starter for internal combustion engines which is simple and compact, foolproof in operation, sturdy in construction, and which can be manufactured and assembled in a simple and inexpensive manner.

It is another object of the present invention to provide a mechanical starter for internal combustion engines of the cable and reel type in which a portion of said starter is directly pivotally mounted to the engine flywheel.

Further objects and advantages of the present invention will become apparent as the following description proceeds and the features of novelty which characterize the invention will be pointed out with particularity in the claims annexed to and forming a part of this specification.

For a better understanding of the present invention reference may be had to the accompanying drawings in which:

Fig. 1 is a sectional view along the crankshaft of an internal combustion engine embodying the mechanical starting mechanism of the present invention;

Fig. 2 is a sectional view taken on line 2—2 of Fig. 1, assuming that Fig. 1 shows the complete structure, with the starting mechanism shown in the position it assumes when the internal combustion engine is running;

Fig. 3 is a partial view of Fig. 2 showing the position of the parts of the starting mechanism while the engine is stationary; and

Fig. 4 is an exploded perspective view of certain parts of the internal combustion engine of Fig. 1 to illustrate the starting mechanism and its relationship to the other engine parts.

Briefly, the present invention is concerned with a built-in mechanical starter for an internal combustion engine of the type used for lawn mowers, outboard motors and the like. The mechanical starter comprises a portion mounted directly on the motor flywheel and another portion housed between the flywheel and the engine itself in a very small space. A single pivoted pawl, specifically shown as mounted on the flywheel, is engageable with teeth or projections on the reel for the starting cable. As the starting cable is actuated the ratchet is always in engagement in a positive manner to rotate the crankshaft of the internal combustion engine. As soon as the engine starts, the centrifugal force will cause the pawl on the flywheel to move out of driving engagement with the ratchet portion on the reel, and a rewind spring draws the starting cable back into the mechanism ready for a subsequent starting operation.

Referring now to the drawings, there is illustrated an internal combustion engine generally designated by the reference numeral 10. This internal combustion engine comprises a crankcase and cylinder housing 11 which might be formed of an aluminum die casting or from any other suitable material. The crankcase has defined therein a suitable bore for receiving therein a cylinder liner 12 within which is reciprocally mounted a piston 13 connected by a suitable connecting rod 14 with a crankshaft 15. This

3

crankshaft 15 is journaled in a suitable bearing 16 supported within the crankcase and cylinder housing 11 and another bearing 17 suitably disposed within a crankcase cover 13 suitably secured to the crankcase and cylinder housing 11 by fastening means 19. The crankshaft 15 has a portion 15a which extends outside the crankcase and cylinder housing 11 and which supports thereon a combined flywheel and magneto assembly 20, a fan 21, the starting mechanism 22 of the present invention, and a suitable power take-off pulley 23.

For the purpose of preventing the operator from coming in contact with the rotating flywheel and magneto assembly and the fan 21, there is provided a flywheel shroud 25 which may be formed of very light metal, which shroud 25 more or less completely encloses the rotating parts extending outside the crankcase 11 including the portion 15a of the crankshaft 15. The shroud 25 is provided with a circular opening 26 through which the end of the crankshaft portion 15a supporting the power take-off pulley 23 is secured. Preferably the power take-off pulley 23 is secured by a suitable set screw 24 engaging a flattened portion 27 at the end of the crankshaft 15.

For the purpose of permitting the fan 21 to draw air into the shroud 25 to cool the internal combustion engine which is preferably provided with the conventional fins 28 for air cooling purposes, the opening 26 is substantially larger than that necessary to accommodate either the crankshaft 15 or the pulley 23. To prevent the operator from inserting a tool or some portion of his body within the opening 26, there is provided a pulley and flywheel screen 29 which is secured so as to rotate with the pulley 23 and crankshaft 15. This screen 29 substantially closes the opening 26 as far as the entry of a foreign object is concerned, but is provided with a plurality of openings 30 through which cooling air may be drawn.

The shroud 25, as illustrated in Fig. 2 of the drawings, may extend over the top of the internal combustion engine 10, as shown, or a separate cover or shroud member may be provided for the top of the cylinder head. The shroud 25 is illustrated as being secured to the engine housing by suitable fastening means 31, 32 and the like. The engine shroud is provided with an opening at the top to accommodate certain portions of the internal combustion engine such as the spark plug generally indicated at 35, and an additional opening 36 provided through which the starting cable 37 to be described in detail hereinafter may extend. Surrounding the opening 36 is a starting cable bushing 38 suitably secured to the shroud 25, the purpose of which will become apparent as the following description proceeds.

The combined flywheel and magneto assembly 20 forms no part of the present invention except as a support for a portion of the starting mechanism. Therefore, the specific construction of the assembly 20 is not set forth in detail and preferably is that disclosed and claimed in a copending Jepson and Craft application Serial No. 402,882, filed January 8, 1954, and assigned to the same assignee as the present application.

In accordance with the present invention the starting mechanism 22 for the internal combustion engine 10 is disposed between the cover 18 for the crankcase and cylinder housing 11 and the combined flywheel and magneto assembly 20, and is confined in a very small space of the order of an inch or so of the length of the crankshaft 15. The starting mechanism 22 includes a rewind spring 40 in the form of a spiral coil of flat spring material coiled about the axis of the crankshaft 15 and nested within a recess 41 (Fig. 1) defined by projections such as 18a of the crankcase cover 13. The mechanical starting mechanism 22 further includes a reel assembly generally designated by the reference numeral 43, best shown in Figs. 1 and 4 of the drawings. This reel assembly includes a main plate 44 which might be in the form of an aluminum die casting having a laterally extending central portion 44a which is rotatably mounted about an annular

4

or hublike extension 18b of the crankcase and cylinder housing 10, and specifically from the cover plate 18 in a manner best shown in Fig. 1 of the drawings. A suitable bearing member 45 may be interposed between the telescoped portions 44a and 18b. The rewind spring 40 is disposed around the hub portion 44a and is nested within the space or recess 41 between the cover 18 and the reel portion 44.

To complete the reel assembly 43, there is provided an annular ratchet plate 46 secured by rivets 47 or other suitable fastening means to the plate 44 so that a winding space is provided for receiving therein the starting cable 37 which is spirally wound therein, as clearly indicated in Fig. 1 of the drawings. The space for receiving the starting cable 37 is relatively narrow so that the cable will be wound therein in a sort of pancake spiral, three or four turns of the cable being capable of readily being retained within the space provided therefor between the plate 44 and the ratchet plate 46. Preferably the plate 44 is provided with a recess 43 therein to permit insertion of the starting cable 37. The starting cable 37 preferably has a somewhat spherical member or ball 49 attached to one end thereof which is inserted through an opening in the plate 44 connected with the recess 48 so that the ball 49 seats in a sort of spherical portion 48a of the recess 48 and thereby readily secures the starting cable 37 to the reel assembly 43 in a simple manner.

In accordance with the present invention the reel assembly or reel member, and specifically the ratchet plate 46 of the reel assembly 43 includes a plurality of lateral projections 46a, which projections extend toward the flywheel member or assembly 20. These projections 46a, arranged in a circle, have discontinuous sections between adjacent projections so that the ends of the projections, which are each of curved shape, are readily engageable by a suitable pawl or the like associated with the flywheel member to be described in detail hereinafter.

So that the starting cable 37 may be readily available to the operator to start the internal combustion engine 10, the cable 37, as was mentioned above, is brought out through the opening 36 and through the starter cable bushing 38. Secured to the end of the starting cable 37 extending outside the shroud 25 is a suitable handle 50 which preferably is of T-shaped construction so that it may readily be grasped between two fingers of the operator's hand. This starting cable handle is preferably made of a material such as rubber or the like and is provided with a suitable insert 51 of material to which the end of the starting cable may be secured. It will be apparent that when the operator grasps the handle 50 and pulls outwardly to withdraw the cable 37 through the opening 36 that the reel assembly 43 will be caused to rotate in a counterclockwise direction, as viewed in Fig. 2 of the drawings, about the hub portion 18a of the closure plate 18.

Such rotatable movement caused by pulling on the cable 37 will tend to wind up the rewind spring 40 which is a torsion spring having one end 40a thereof secured to a spring pin 53 fastened to the plate 44 of the reel assembly 43. Preferably the hub portion 44a of the plate 44 is provided with a recess 54 within which recess there is disposed the spring pin 53. The inner end 40a of the rewind spring 40 is preferably U-shaped, as illustrated, whereby it may readily be hooked over the spring pin 53. The outer end of the rewind spring 40 is also provided with a U-shaped or hooked portion 40b for hooking onto a spring pin 55 suitably secured to the cover 18. By providing the ends of the spring 40 with these hooked-shaped portions 40a and 40b, and additionally providing the spring pins 53 and 55, assembly of the mechanism can readily be accomplished. By merely rotating the reel assembly 43 during the initial assembly operation the hooked ends 40a and 40b of the spring 40 can be moved into hooked engagement with the spring pins 53 and 55.

5

6

In order to hold the reel assembly 43 in position on the hub 18b, a suitable spacer washer 56 and a lock retaining ring 57 are provided. The spacer washer 56 is slipped over the end of the hub portion 18a projecting beyond the reel assembly 43, as is clearly evident from Fig. 1 of the drawings, and the lock or retaining ring 57 is inserted in a suitable recess 58 provided therefor adjacent the end of the hub portion 18a.

For the purpose of converting the rotatable motion of the reel assembly 43 about the hub portion 18a and hence about the axis of the crankshaft 15 in response to a pull on the starting cable 37 to rotary motion of the crankshaft 15, there is provided in accordance with the present invention a suitable pawl 60 pivotally mounted about a pivot pin 61 secured to the side of the magneto and flywheel assembly 20 adjacent the reel assembly 43. The pawl 60 is pivoted adjacent one end thereof so as to provide an elongated somewhat hook-shaped portion 60a extending a substantial distance away from the pivot pin 61, and a pawl portion 60b closely adjacent the pivot pin 61. A suitable spring 62 normally biases the pawl 60 in a counterclockwise direction, as viewed in Figs. 2 and 3 of the drawings, with the end 60a engaging the crankshaft 15, thereby limiting the maximum counterclockwise rotation thereof. Fig. 3 shows the portion 60a of the pawl 60 engaging the crankshaft 15, and biased to that position by virtue of the spring 62, which is a torsion spring having one end 62a secured to the pawl 60 and the other end 62b engaging a suitable pin 64 secured to the flywheel and magneto assembly 20. The intermediate portion 62c of the spring 62 is wound around a suitable hub 65 secured to the pawl 60 and pivotally mounted on pivot pin 61. When the pawl 60 is in the position shown in Fig. 3, the pawl portion 60b thereof moves into the spaces between the ratchet teeth 46a, so that as the reel assembly 43 is rotated one of the ratchet teeth will engage the pawl portion 60b and cause simultaneous rotation of the flywheel and magneto assembly 20. Since, as will be described hereinafter, the flywheel and magneto assembly 20 is secured to the crankshaft 15, the crankshaft 15 will be rotated with the reel assembly 43 with the resultant starting of the internal combustion engine 10, assuming that the fuel supply and ignition conditions are correct.

It should be understood that although the pawl 60 has been illustrated as mounted on the flywheel member, and the ratchet teeth 46a are part of the reel member, obviously these parts could readily be interchanged.

The method of securing the flywheel and magneto assembly 20 to the crankshaft 15 forms no part of the present invention. However, as illustrated in Figs. 1 and 4 of the drawings, the crankshaft 15 is provided with a suitable keyway 66 for receiving therein a key 67 which corresponds with a key slot 68 in the hub of the flywheel and magneto assembly 20. The fan 21 is similarly keyed to the crankshaft 15 in any suitable manner, and, as illustrated, a key washer 70 and a crankshaft nut 71 are secured to the crankshaft, which is suitably threaded as indicated at 69 to accommodate the crankshaft nut 71. It will be appreciated that the power take-off pulley 23 may drive any suitable mechanism such as a lawn mower if the internal combustion engine is used to operate a lawn mower or any other device.

As is fully disclosed in the above-mentioned copending Jepson and Craft application, the flywheel and magneto assembly including magnet members cooperates with a suitable core and coil assembly not shown in the drawings but disposed within a suitable housing defined by the coil cover 70 shown in Fig. 4 of the drawings. It should be appreciated that the details of the internal combustion engine described above are by way of example only and the specific internal combustion engine described is disclosed in a copending Jepson application Serial No. 464,020, filed October 22, 1954.

Fig. 3 of the drawings discloses the mechanism in the

position it assumes when the internal combustion engine is stationary. It will be apparent that as soon as the internal combustion engine begins to rotate, the centrifugal force acting on the pawl 60, whose long arm 60a is much heavier than its short arm 60b, causes the long arm to move away from the axis of the shaft 15 and against the stop 63, as shown in Fig. 2 of the drawings, which is the position the parts assume during the running condition of the internal combustion engine 10. In this position, as is obvious from Fig. 2 of the drawings, the pawl portion 60b of the pawl 60 is completely free of the ratchet teeth 46a. Thus, there has been provided a very simple mechanical starter for an internal combustion engine which is of sturdy construction, which is disposed in a place completely protected from dirt and the like, and which is confined in a very small space so as to have substantially no effect on the engine size. This starter mechanism is moreover supported from the engine crankcase already provided, and, unlike prior art devices, is not supported from the motor shroud with the resultant requirement of a very heavy and expensive shroud. By virtue of the large diameter of the hub 18a, a rigid bearing for the reel assembly 40 is provided. The pawl 60 is always biased into engagement with the ratchet teeth 46 whenever the engine is stationary, so that it is always in condition for immediate starting. By utilizing a single pawl a very simple mechanism is provided without requiring any equalizer mechanism or the like to make sure that a plurality of pawls are rendered effective and ineffective simultaneously.

In view of the detailed description included above, the operation of the mechanical starting mechanism for an internal combustion engine described above will readily be apparent to those skilled in the art and no further description thereof is included. Moreover, the assembly of the starting mechanism with the internal combustion engine, as described above is very simple, rewind spring 40 being first put in position, after which the reel assembly 43 is moved into position for rotation about the hub 18a. The reel is then turned until the ends 40a and 40b of the rewind spring hook the corresponding pins 53 and 55.

While there has been illustrated and described what is at present believed to be the preferred embodiment of the present invention, it will be apparent that numerous modifications and changes of the present invention will occur to those skilled in the art. It is aimed in the appended claims to cover all such changes and modifications as fall within the true spirit and scope of the present invention.

What is claimed as new and desired to be secured by Letters Patent of the United States is:

1. A starting mechanism for an internal combustion engine having a cylinder and crankcase housing including a crankcase cover secured to said housing, the combination of an annular projection on said housing surrounding a crankshaft journaled in said housing and having a portion extending outside said housing through an opening concentric with said annular projection, a flywheel member secured to the portion of said crankshaft extending outside said housing, a reel member rotatably mounted on said annular projection between said housing and said flywheel member, a pawl pivotally secured to one of said members, a cooperating circular ratchet secured to the other of said members, and means for rotating said reel to cause said pawl and ratchet to rotate said flywheel member and hence said crankshaft in response to rotation of said reel member.

2. The starting mechanism of claim 1 in which said last-mentioned means comprises a cable partially wound upon said reel member.

3. The starting mechanism of claim 1 in which said pawl is pivotally secured to said flywheel member.

4. The starting mechanism of claim 1 in which said annular projection is integral with said crankcase cover.

5. In a rotatable starter mechanism for an internal combustion engine having a cylinder and crankcase housing including a crankcase cover secured to said housing, the combination of an annular projection on said housing surrounding a crankshaft journaled in said housing and having a portion extending outside said housing through an opening concentric with said annular projection, a flywheel member secured to the portion of said crankshaft extending outside said housing, a reel member rotatably mounted on said annular projection between said housing and said flywheel member, a pawl pivotally secured to one of said members, a cooperating circular ratchet secured to the other of said members, a cable having one end secured to said reel member and the other end provided with means to permit an operator to pull said cable and cause rotation of said flywheel member through engagement of said pawl and ratchet, a torsion spring surrounding said crankshaft and disposed between said housing and said reel member, and means for connecting the ends of said spring to said housing and said reel member to insure rewinding on said reel member of said cable following a starting operation.

6. A rotatable starter mechanism for an engine having a cylinder and crankcase housing, the combination of an integral projection on said housing, a crankshaft journaled in said housing and having a portion thereof extending outside said housing with its axis perpendicular to a plane transverse to the longitudinal axis of said projection, a flywheel member secured to the portion of said crankshaft extending outside said housing, a reel member rotatably mounted on said projection, a pawl pivotally secured to one of said members, a cooperating circular ratchet secured to the other of said members, means for biasing said pawl into engagement with said ratchet, and means for rotating said reel with said pawl and ratchet engaged to rotate said flywheel member and hence said crankshaft in response to rotation of said reel member.

7. The mechanism of claim 5 in which said torsion spring is provided with a hook for engaging cooperating pins on said housing and said reel member.

8. A starting mechanism for an internal combustion engine having a cylinder and crankcase housing including a crankcase cover secured to said housing, the combination of an annular projection on said housing surrounding a crankshaft journaled in said housing and having a portion extending outside said housing through an opening concentric with said annular projection, a flywheel secured to the portion of said crankshaft extending outside said housing, a reel rotatably mounted on said annular projection between said housing and said flywheel, a single pawl pivotally secured to said flywheel, a cooperating circular ratchet secured to said reel, spring means for biasing said pawl into engagement with said ratchet, said pawl having a portion engaging said crank-

shaft to limit pivotal movement in one direction thereof, and means for rotating said reel to cause said pawl and ratchet to rotate said flywheel and hence said crankshaft in response to rotation of said reel, said pawl being moved out of engagement with said ratchet by centrifugal force upon rotation of said crankshaft by said engine.

9. In a rotatable starter mechanism for an internal combustion engine having a cylinder and crankcase housing including a crankcase cover secured to said housing, the combination of an annular projection on said housing surrounding a crankshaft journaled in said housing and having a portion extending outside said housing through an opening concentric with said annular projection, a flywheel secured to the portion of said crankshaft extending outside said housing, a reel rotatably mounted on said annular projection between said housing and said flywheel, a pawl pivotally secured to said flywheel, a cooperating circular ratchet secured to the side of said reel adjacent said flywheel, a cable having one end secured to said reel and the other end provided with means to permit an operator to pull said cable and cause rotation of said flywheel through engagement of said pawl and ratchet, a torsion spring surrounding said crankshaft and disposed between said housing and said reel, and means for connecting the ends of said spring to said housing and said reel to insure rewinding on said reel of said cable following a starting operation, said starter mechanism being disposed in a space not substantially in excess of one inch along said crankshaft.

10. In a starting mechanism for an internal combustion engine having a cylinder and crankcase housing, the combination of an integral circular projection on said housing, a crankshaft journaled in said housing and having a portion thereof extending outside said housing with its axis parallel with the longitudinal axis of said projection, a flywheel secured to the portion of said crankshaft extending outside said housing, a reel rotatably mounted on said projection, a pawl pivotally secured to said flywheel, a cooperating circular ratchet secured to said reel, means for biasing said pawl into engagement with said ratchet, means for rotating said reel with said pawl and ratchet engaged to rotate said flywheel and hence said crankshaft in response to rotation of said reel, and a shroud enclosing said reel and flywheel to prevent an operator from coming in contact therewith, said shroud being formed of relatively light material.

References Cited in the file of this patent

UNITED STATES PATENTS

1,858,583 Fahrney ----- May 17, 1932

FOREIGN PATENTS

131,893 Australia ----- Mar. 24, 1949