

[54] **MAGNETIC PIN TUMBLER LOCK**
 [72] Inventor: **Mitsumasa Taniyama, Osaka, Japan**
 [73] Assignee: **Goal Company Limited, Osaka, Japan**
 [22] Filed: **June 29, 1970**
 [21] Appl. No.: **50,397**

3,512,382	5/1970	Check et al.....	70/276
3,416,336	12/1968	Felson	70/276
3,418,833	12/1968	Kerr.....	70/421
1,669,115	5/1928	Anakin	70/421 X
1,114,709	10/1914	Muller	70/364 A
1,154,078	9/1915	Upton.....	70/378 X

Primary Examiner—Albert G. Craig, Jr.
Attorney—Wenderoth, Lind & Ponack

[30] **Foreign Application Priority Data**
 June 30, 1969 Japan.....44/51945
 Aug. 23, 1969 Japan.....44/66616
 Oct. 28, 1969 Japan.....44/86161
 Jan. 17, 1970 Japan.....45/4721
 May 19, 1970 Japan.....45/49269

[52] U.S. Cl.70/276, 70/375, 70/464
 [51] Int. Cl.E05b 27/00, E05b 47/00
 [58] Field of Search.....70/276, 364 A, 373, 375, 389,
 70/413, 421

[56] **References Cited**

UNITED STATES PATENTS

3,393,541 7/1968 Wake.....70/276

[57] **ABSTRACT**

An improved magnetic pin tumbler lock is controllable by magnetic attraction and repulsion in such a manner that the magnetic attraction or repulsion established due to the relative positions and polarity orientations of fixed magnetic pins placed in a plurality of pin bores arranged in line in the inside face of the lock cylinder, of movable magnetic pins slidably installed in pin bores to mate with the fixed magnetic pins, and of magnetic pieces provided in the key to be inserted through the key slot located at the center of the lock plug allow locking and unlocking of the lock. Non-magnetic pieces are associated with the movable magnetic pins and tread the shear line represented by a boundary line between the cylinder and the plug when the lock is locked.

2 Claims, 16 Drawing Figures

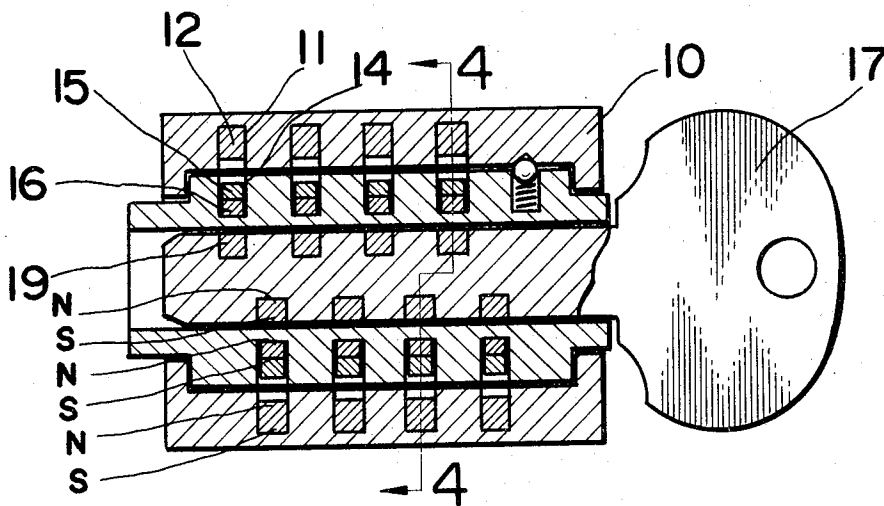

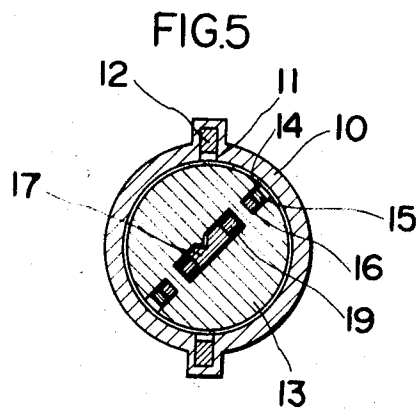
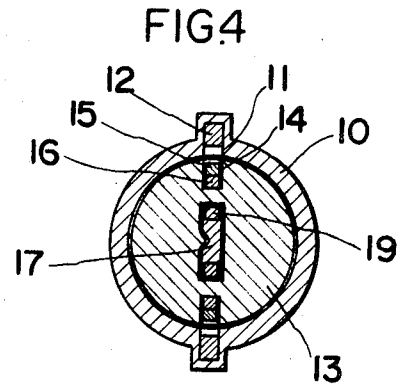
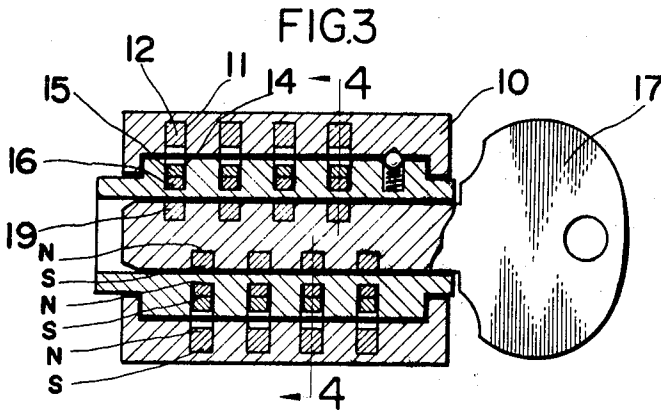
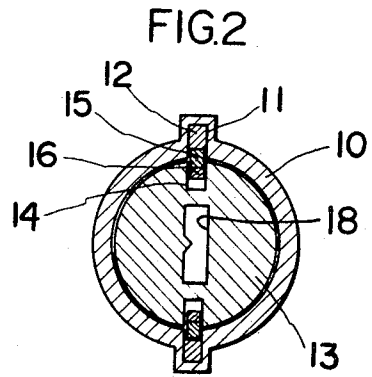
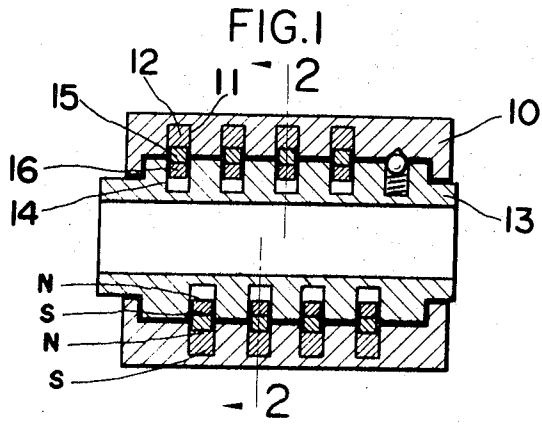

MITSUMASA TANIYAMA,
INVENTOR.

BY *Walter G. ...*

Attorneys

FIG.6

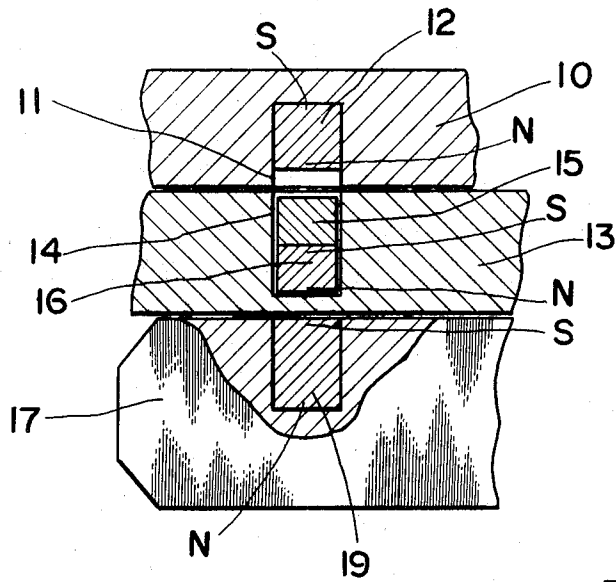

FIG.7

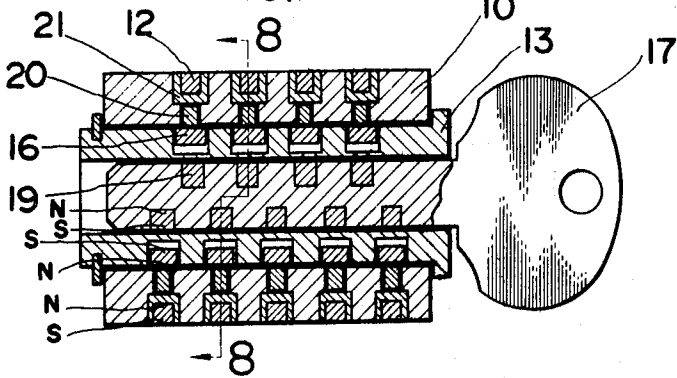

FIG.8

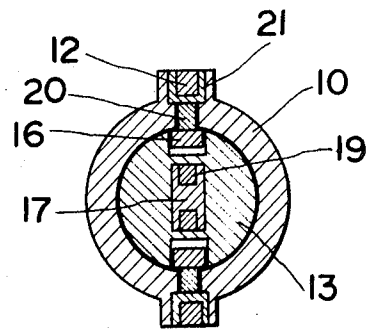

FIG.9

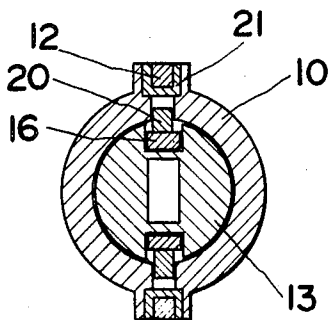
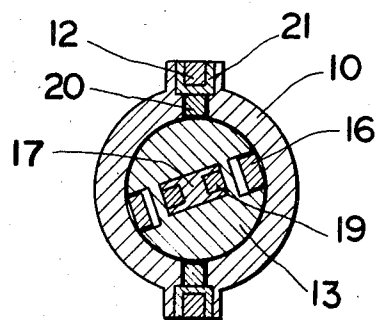

FIG.10



MITSUMASA TANIYAMA,
INVENTOR.

BY *Wendell L. Brock*

Attorneys

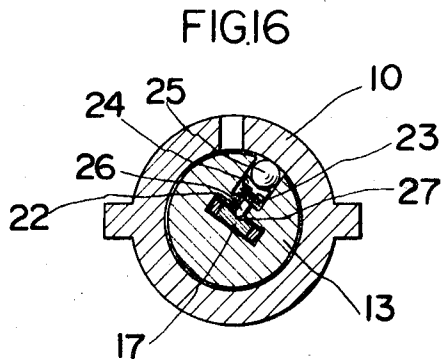
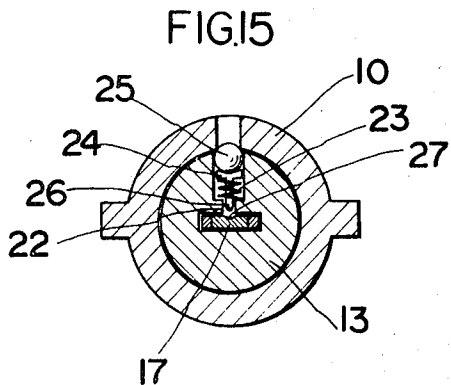
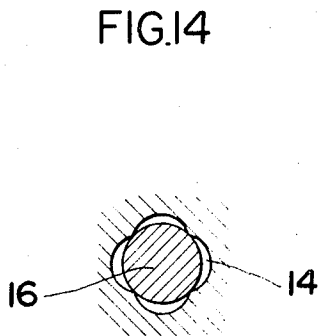
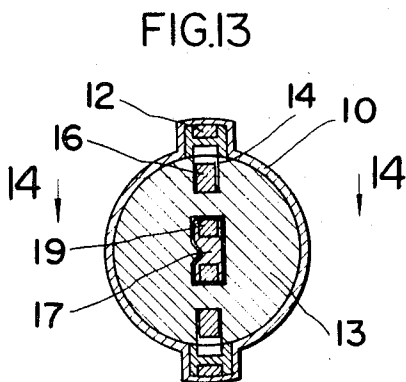
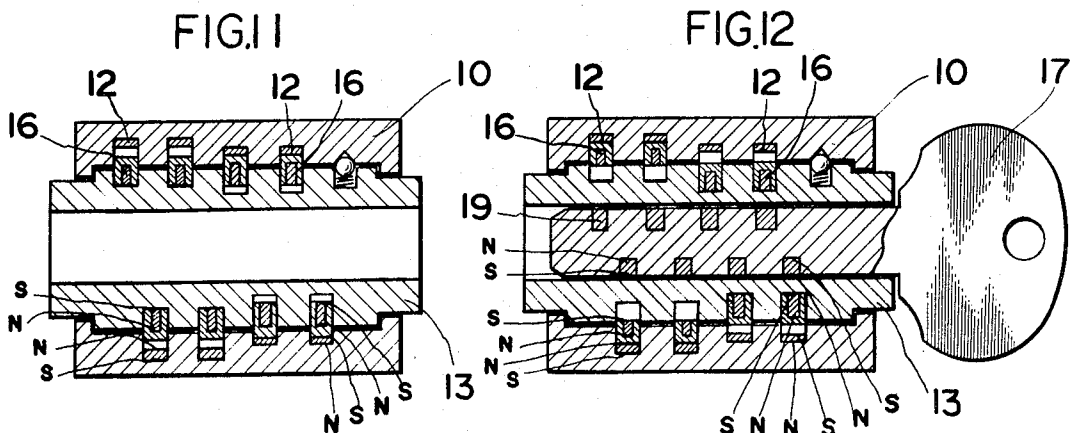

MITSUMASA TANIYAMA,
INVENTOR.

BY *Wendroth L. Schneck*

Attorneys

MAGNETIC PIN TUMBLER LOCK

BACKGROUND OF THE INVENTION

Disadvantages common to various types of high class cylinder locks such as conventional mechanical pin tumbler, disc tumbler and lever tumbler locks are the difficulty in inserting the key into the key slot in the plug due to the irregular edge of the key blade and restriction imposed on acceptable positions for lock installation. In conventional magnetic pin tumbler locks where the shear line is treaded by movable magnetic pins which are pushed up according to the irregular edge of the key blade, and then caused to be lowered by the gravity thereof alone, the movable pins can be moved in the vertical direction only. On the other hand, if springs are used to return the magnetic pins, they are subject to fatigue resulting in the reduced service life.

Of late, there has been proposed a magnetic pin tumbler lock allegedly having been made free from the above disadvantages, and wherein so-called attraction — and repulsion — unlocking are accomplished to shift the movable magnetic pin away from the shear line by magnetic attraction or repulsion respectively offered by the magnetic piece provided in the key exceeding the magnetic force set up between the fixed magnetic pin located in either the cylinder or the plug and the movable magnetic pin, such lock depending on the principle of magnetic attraction between dissimilar polarities and repulsion between similar polarities. This type of magnetic pin tumbler lock, however, is still accompanied by such difficulty that it cannot endure the repeated lockings and unlockings for a prolonged period, because the permanent magnet movable pins are made from a sintered ferro-alloy which is poor in mechanical strength and is thus brittle. Thus, the pins are subject to shearing when they thread the shear line and a force is applied to compel rotation of the plug. Also, the determination of the proper distance between the fixed magnetic pin and the movable magnetic pin to ensure the positive movement of the movable magnetic pin away from the locking position on the shear line to the unlocking position off said line is difficult.

These difficulties have so far represented a bottleneck impeding the successful commercial production of the magnetic pin tumbler lock.

For the conventional type of the magnetic pin tumbler lock, a plurality of combinations of magnetic poles for different unlocking characteristics have been achieved in such a manner that an unlocking mechanism of either the attraction or repulsion type is incorporated in a given lock and the combination of polarity orientations of N and S poles in a given unlocking mechanism may be changed according to a particular key design. This type of changing of the key characteristics is, however, characteristically disadvantageous in that the lock cylinder may be struck on the sides thereof with a suitable tool, such as a hammer or the like, and cause the pins to overcome the magnetic force of the fixed magnetic pins, thus causing the lock to unlock.

Another drawback inherent in the conventional magnetic pin tumbler lock is due to the fact that the entry of water, oil, fat, dust or any other dirt into the lock, and especially the deposit thereof between the pin bore of the plug and the movable magnetic pin causes a substantial rise in friction between the pin bore and the pin. This results in the prevention of smooth movement of the pin, and can cause the lock to be incapable of unlocking.

One of the difficulties associated with another conventional type of magnetic pin tumbler lock having a T-shaped movable pin loaded with a coil spring and the bottom end thereof extending through a small opening machined in the wall of the plug installed rotatably in the lock cylinder and so constructed that the prevention of the unintentional release of the inserted key is assured by engagement of the bottom end of said T-shaped movable pin with a notch in the key, is that alignment of the top end of the T-shaped movable pin with the pin bore in the cylinder for withdrawal of the key is substantially difficult.

BRIEF SUMMARY OF THE INVENTION

The primary object of the present invention is to provide an improved magnetic pin tumbler lock free from any of the above described difficulties and having a simple construction, and capable of smooth operation.

Another object of the present invention is to provide an improved magnetic pin tumbler lock of such construction that the rotation of the plug in the shear line places a load only on non-magnetic pieces mounted on and integral with the top of the movable magnetic pins. The non-magnetic pieces have high mechanical strength and are properly spaced from the fixed magnetic pin in the cylinder for ensuring a sufficient attraction depending on the positions and orientation of polarity of the magnetic components.

A further object of the present invention is to provide an improved magnetic pin tumbler lock assured of the prevention of unlawful unlocking achievable by striking the lock cylinder.

A still further object of the present invention is to provide an improved magnetic pin tumbler lock having an extended life in spite of the entry therein of water, oil, fat, dust or any other dirt taking place in the course of prolonged period of use, whereby the smooth and positive movement of the movable magnetic pin is ensured.

Still another object of the present invention is to provide a magnetic pin tumbler lock comprising an improved means for preventing the unintentional release of an inserted key while the plug is being turned.

All the objects of the present invention are achieved by the combination and operation of various parts setting up a magnetic pin tumbler lock according to the present invention.

Other objects and a fuller understanding of the present invention may be achieved by referring to the following description and claims, taken in conjunction with the accompanying drawings.

BRIEF DESCRIPTION OF THE DRAWINGS

FIG. 1 is a longitudinal sectional view of a magnetic pin tumbler lock embodying the present invention, with the movable magnetic pins in the locked position on shear line;

FIG. 2 is a cross-sectional view taken on the line 2—2 in FIG. 1;

FIG. 3 is a longitudinal sectional view of a magnetic pin in the unlocking position;

FIG. 4 is a cross-sectional view taken on the line 4—4 in FIG. 3;

FIG. 5 is a cross-sectional view of a magnetic pin tumbler lock embodying the present invention with the plug shown in FIG. 4 turned;

FIG. 6 is a partially cut away and enlarged elevation showing the positional relation between the fixed magnetic piece in the cylinder, the movable magnetic pin in the plug and the magnetic piece provided in the key;

FIG. 7 is a longitudinal sectional view of a magnetic pin tumbler lock of the repulsion unlocking type in accordance with the present invention;

FIG. 8 is a cross-sectional view taken on the line 8—8 in FIG. 7;

FIG. 9 is a cross sectional view of the magnetic pin tumbler lock of FIG. 8, but with the key withdrawn;

FIG. 10 is a cross-sectional view of the magnetic pin tumbler lock shown in FIG. 8 but with the plug turned;

FIG. 11 is a longitudinal sectional view of a magnetic pin tumbler lock embodying the present invention of the combined attraction and repulsion unlocking type, with the movable magnetic pins moved onto the shear line for locking;

FIG. 12 is a longitudinal sectional view of the magnetic pin tumbler lock shown in FIG. 11 but with the key inserted in the plug and with the movable magnetic pins moved off the shear line for unlocking;

FIG. 13 is a cross-sectional view of a magnetic pin tumbler lock of the attractive unlocking type;

FIG. 14 is an enlarged horizontal sectional view taken along line 14—14 shown in FIG. 13;

FIG. 15 is a cross-sectional view of a magnetic pin tumbler lock embodying the present invention, with the key ready for free withdrawal; and

FIG. 16 is a cross sectional view of a magnetic pin tumbler lock embodying the present invention, the plug being rotated and the key not ready for free withdrawal.

DETAILED DESCRIPTION OF THE INVENTION

As illustrated in detail in FIG. 1 and FIG. 2, a movable magnetic pin 16 has a non-magnetic piece 15 integrally mounted thereon which may be composed of synthetic resin, aluminum, stainless, copper alloy or the like and is installed slidably in the pin bore 14 located in series in the outer face of and along the longitudinal axis of the plug 13. Plug 13 is installed loosely in the cylinder 10 such that pins 16 align with the fixed magnetic pieces 12 in each of the pin bores 11 located in series in the inner face of and along the longitudinal axis of cylinder 10. Movable magnetic pins 16 are attracted by pins 12 due to the magnetic force produced between the dissimilar polarities thereof in such a manner that non-magnetic pieces 15 tread the shear line. When key 17 is inserted all the way into the center slot 18 in the plug 13 as shown in FIG. 3 and FIG. 4, the movable magnetic pins 16 are attracted by magnetic pieces 19 adapted to align with pins 16. Thus, the magnetic force produced due to the dissimilarity of polarity between pins 16 and pieces 19 overcomes the attraction between fixed magnetic pieces 12 and pins 16. This in turn enables the free rotation of the plug 13 in the cylinder 10 as illustrated in FIG. 5, because the non-magnetic pieces 15 are forced all the way into the pin bores 14 in the plug 13, and are thus shifted away from the shear line.

In as much as the non-magnetic pieces 15 tread the shear line when the lock is locked, any force applied to the plug in an attempt to force rotation thereof is applied only to the non-magnetic members. These elements have high mechanical strength to thus ensure extended durability of the lock. The provision of non-magnetic pieces 15 also aid in controlling the relative positions of the fixed magnetic piece 19 provided in the key, the movable magnetic pin 16 and the fixed magnetic piece 12 to ensure smooth unlocking as illustrated in FIG. 6.

When key 17 is inserted all the way into the key slot in the embodiment shown in FIG. 7, FIG. 8, FIG. 9 and FIG. 10, the fixed magnetic piece 19 provided in the key 17 repels the movable magnetic pin 16 due to the similarity of polarity orientation thereof, with the result that the movable magnetic pin 16 and the movable non-magnetic piece 20 are forced upwardly. The pin 16 is abutted against the inside surface of the cylinder 10, while the piece 20 is shifted into the pin bore 11 out of the shear line, thus allowing free rotation of the plug 13 for unlocking. When the key 17 is removed from the lock, the fixed magnetic piece 12 repels the movable magnetic pin 16 due to the equal polarity orientation thereof, resulting in the corresponding shift of magnetic pin 16 and movement of the movable non-magnetic piece 20 to tread the shear line.

In the embodiment illustrated in FIG. 11, those movable pins 16 of the attraction unlocking type can be shifted from the shear line by striking the outside of the lock cylinder. This is, however, not the case with those movable pins 16 of the repulsion unlocking type, where the movable magnetic pin 16 stays unmoved riding over the shear line despite the striking. In this manner, the shear line is always treaded by at least one of the movable magnetic pins 16. The plug is allowed to be rotated only after insertion of the key all the way into the lock as illustrated in FIG. 12.

In a magnetic pin tumbler lock of the attraction unlocking type as illustrated in FIG. 13, the unique form of the cross sectional contour of the pin bore 14 in the plug 13 is designed to provide a line contact with the movable magnetic pin 16 as shown in FIG. 14 and removes the possibility of establishing undesirable frictional resistance of said magnetic pin 16 due to the surface tension of water, oil, fat, dust or any other dirt, which has entered the lock. This ensures the permanent smoothness of sliding of magnetic pins 16.

FIG. 15 illustrates another embodiment of the present invention, where an opening 22 is provided through the bottom of the pin bore 14 in the plug 13 to accept the bottom end 26 of the T-shaped movable pin 24 biased upwardly by the coil spring 23 and having the ball 25 on the top thereof. The bottom end 26 of said T-shaped movable pin penetrating the bottom opening 22 is permitted to engage with and disengage from the notch 27 in the key 17. As noted in FIG. 16, when the plug 13 is turned in the cylinder 10 with the key inserted all the way into the lock, end 26 of the T-shaped movable pin 24 is forced into notch 27 due to the ball 25 applying a downward pressure exceeding the force provided by the coil spring 23. This prevents the unintentional withdrawal of the key from the lock. Partial entry of the ball 25 into the pin bore 11 in the cylinder 10 gives rise to disengagement of the T-shaped movable pin 24 from the notch 27 in the key 17 to ensure the smooth withdrawal of key 17 from the lock.

As will be apparent, the magnetic pin tumbler lock according to the present invention is characterized by simple construction, permanently smooth and positive locking and unlocking, reduced cost and excellent durability.

Although the present invention has been described with a certain degree of particularity, it is understood that the present disclosure has been made only by way of example and that numerous changes in the details of construction and the combination and arrangement of the parts may be resorted to without departing from the spirit and the scope of the present invention.

What is claimed is:

1. A magnetic pin tumbler and lock assembly comprising a cylinder having a circular longitudinal opening therethrough, a plurality of pin holes extending transversely of said cylinder and communicating with said longitudinal opening, and a plurality of magnetic pieces fixed in said pin bores; a plug fitting into said longitudinal opening and having a longitudinal key slot therein, said cylinder and plug forming therebetween a shear line, a plurality of pin bores extending transversely of said plug on the outer periphery thereof and aligned with said corresponding pin bores in said cylinder, a plurality of movable magnetic pins positioned in said pin bores of said plug and having a magnetic polarity to be attracted by said fixed magnetic pieces, and a plurality of non-magnetic pieces fixed to said movable magnetic pins only at the surfaces thereof closest said fixed magnetic pieces, said non-magnetic pieces extending toward said fixed magnetic pieces and dimensioned to tread said shear line only when said movable magnetic pins are attracted toward said fixed magnetic pieces; and a key adapted to fit into said key slot and having thereon a plurality of magnetic pieces aligning with said movable magnetic pins, said key magnetic pieces having a magnetic polarity to attract said movable magnetic pins, the attraction between said key magnetic pieces and said pins being stronger than the attraction between said fixed magnetic pieces and said pins.

2. A magnetic pin tumbler and lock assembly comprising a cylinder having a circular longitudinal opening therethrough, a plurality of pin bores extending transversely of said cylinder and communicating with said longitudinal opening, and a plurality of magnetic pieces fixed in said pin bores; a plug fitting into said longitudinal opening and having a longitudinal key slot therein, said cylinder and plug forming therebetween a shear line, a plurality of pin bores extending transversely of said plug on the outer periphery thereof and aligned with but larger than said corresponding pin bores in said cylinder, a plurality of movable magnetic pins positioned in said pin bores of said plug having a magnetic polarity to be repelled by said fixed magnetic pieces, and a plurality of non-magnetic pieces positioned in said cylinder pin bores and abutted to said movable magnetic pins only at the surfaces thereof closest said fixed magnetic pieces, said non-magnetic pieces extending toward said fixed magnetic pieces and dimensioned to tread said shear line only when said movable magnetic pins are repelled away from said fixed magnetic pieces; and a key adapted to fit into said key slot and having thereon a plurality of magnetic pieces aligning with said movable magnetic pins, said key magnetic

pieces having a magnetic polarity to repel said movable magnetic pins, the repulsion between said key magnetic pieces and said pins being stronger than the repulsion between said fixed magnetic pieces and said pins, said movable magnetic pins abutting the inner periphery of said cylinder when said key is in said key slot. 5

* * * * *

10

15

20

25

30

35

40

45

50

55

60

65

70

75