



- (51) **International Patent Classification:**  
G06F 3/03 (2006.01)
- (21) **International Application Number:**  
PCT/IB2013/050628
- (22) **International Filing Date:**  
24 January 2013 (24.01.2013)
- (25) **Filing Language:** English
- (26) **Publication Language:** English
- (30) **Priority Data:**  
13/357,809 25 January 2012 (25.01.2012) US
- (71) **Applicant:** NOKIA CORPORATION [FI/FI]; Keilalahdentie 4, FIN-02150 Espoo (FI).
- (72) **Inventors:** PAASOVAARA, Pii Susanna; Lohilantie 5 C 5, FI-37550 Lempäälä (FI). KILDAL, Johan; Mesitytönkatu 9, C 40, FI-00180 Helsinki (FI). REPONEN, Erika; Tampellan Esplanadi 6 D 15, FI-33100 Tampere (FI).
- (74) **Agents:** HIGGIN, Paul et al.; 48 Friar Gate, Derby, Derbyshire DE1 1GY (GB).
- (81) **Designated States** (unless otherwise indicated, for every kind of national protection available): AE, AG, AL, AM, AO, AT, AU, AZ, BA, BB, BG, BH, BN, BR, BW, BY,

BZ, CA, CH, CL, CN, CO, CR, CU, CZ, DE, DK, DM, DO, DZ, EC, EE, EG, ES, FI, GB, GD, GE, GH, GM, GT, HN, HR, HU, ID, IL, IN, IS, JP, KE, KG, KM, KN, KP, KR, KZ, LA, LC, LK, LR, LS, LT, LU, LY, MA, MD, ME, MG, MK, MN, MW, MX, MY, MZ, NA, NG, NI, NO, NZ, OM, PA, PE, PG, PH, PL, PT, QA, RO, RS, RU, RW, SC, SD, SE, SG, SK, SL, SM, ST, SV, SY, TH, TJ, TM, TN, TR, TT, TZ, UA, UG, US, UZ, VC, VN, ZA, ZM, ZW.

- (84) **Designated States** (unless otherwise indicated, for every kind of regional protection available): ARIPO (BW, GH, GM, KE, LR, LS, MW, MZ, NA, RW, SD, SL, SZ, TZ, UG, ZM, ZW), Eurasian (AM, AZ, BY, KG, KZ, RU, TJ, TM), European (AL, AT, BE, BG, CH, CY, CZ, DE, DK, EE, ES, FI, FR, GB, GR, HR, HU, IE, IS, IT, LT, LU, LV, MC, MK, MT, NL, NO, PL, PT, RO, RS, SE, SI, SK, SM, TR), OAPI (BF, BJ, CF, CG, CI, CM, GA, GN, GQ, GW, ML, MR, NE, SN, TD, TG).

**Declarations under Rule 4.17:**

- as to the applicant's entitlement to claim the priority of the earlier application (Rule 4.17(iii))

**Published:**

- without international search report and to be republished upon receipt of that report (Rule 48.2(g))

(54) **Title:** CONTORTION OF AN ELECTRONIC APPARATUS

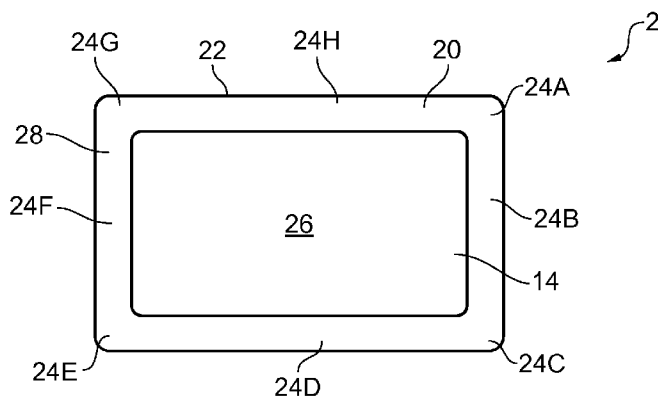

FIG. 3

(57) **Abstract:** An apparatus including: a body configured for resilient contortion from a neutral equilibrium shape by a user, the body having an exterior surface that resiliently contorts in response to user provision of a force, wherein the body defines, proximal to a perimeter of a face of the body, at least a first portion of an exterior surface of the apparatus and a second portion of an exterior surface of the apparatus that opposes the first portion across the face, wherein user provision of a force in a first direction results in a first contortion of the exterior surface and user provision of a force in a second direction, opposite to the first direction, results in a second contortion of the exterior surface; and electronic circuitry including at least a processor configured to provide consistent meaning across a plurality of different software applications for user provision of a force in the first direction to the first portion of the exterior surface and to provide consistent meaning across the plurality of applications for user provision of a force in the first direction to the second portion of the exterior surface.



1

## TITLE

Contortion of an electronic apparatus

## FIELD OF THE INVENTION

5

Embodiments of the present invention relate to contortion of an electronic apparatus. In particular, they relate to controlling an apparatus by contorting the apparatus.

## 10 BACKGROUND TO THE INVENTION

There are various different ways in which a user can control an apparatus via a man-machine-interface (MMI). For example, the apparatus may comprise a cursor control device such as a mouse or trackball. For example, the apparatus may have devices that enable tactile actuation such as keys, touch screens etc. For example, the apparatus may have devices that enable audio actuation such as a microphone and voice recognition circuitry.

15

## BRIEF DESCRIPTION OF VARIOUS EMBODIMENTS OF THE INVENTION

20

According to some but not necessarily all examples there may be provided an apparatus comprising: a body configured for resilient contortion from a neutral equilibrium shape by a user, the body having an exterior surface that resiliently contorts in response to user provision of a force, wherein the body defines, proximal to a perimeter of a face of the body, at least a first portion of an exterior surface of the apparatus and a second portion of an exterior surface of the apparatus that opposes the first portion across the face, wherein user provision of a force in a first direction results in a first contortion of the exterior surface and user provision of a force in a second direction, opposite to the first direction, results in a second contortion of the exterior surface; and electronic circuitry including at least a processor configured to provide consistent meaning across a plurality of different software applications

30

2

for user provision of a force in the first direction to the first portion of the exterior surface and to provide consistent meaning across the plurality of software applications for user provision of a force in the first direction to the second portion of the exterior surface.

5

According to some but not necessarily all examples there may be provided an apparatus comprising: a body configured for resilient contortion from a neutral equilibrium shape by a user, the body having an exterior surface that resiliently contorts in response to user provision of a force but contorts differentially dependent upon which side of the body the force is provided;

10

wherein the body defines, proximal to a first portion of a perimeter of a first side of a face of the body, first portions of an exterior surface of the apparatus and defines, proximal to a second portion of the perimeter of a second side of the face of the body, at least a second portion of an exterior surface of the apparatus; wherein user provision of a force in a first direction to any of the first portions results in a first contortion of the exterior surface to a different extent than user provision of the same force in the first direction to the second portion; and electronic circuitry including at least a processor configured to provide a first function in response to user provision of a force in a first direction to the first portions and to provide a second function in response to user provision of the same force in the first direction to the second portion.

15

20

25

30

According to some but not necessarily all examples there may be provided an apparatus comprising: a body configured for resilient contortion from a neutral equilibrium shape, the body having an exterior surface that resiliently contorts in response to provision of a force, wherein the body defines, proximal to a perimeter of a face of the body, at least a first portion of an exterior surface of the apparatus and a second portion of an exterior surface of the apparatus that opposes the first portion across the face, wherein provision of a force in a first direction results in a first contortion of the exterior surface and provision of a force in a second direction, opposite to the first direction, results in a second contortion of the exterior surface; and

3

electronic circuitry including at least a processor configured to provide consistent meaning across a plurality of different software applications for provision of a force in the first direction to the first portion of the exterior surface and to provide consistent meaning across the plurality of software applications for provision of a force in the first direction to the second portion of the exterior surface.

### BRIEF DESCRIPTION OF THE DRAWINGS

10 For a better understanding of various examples of embodiments of the present invention reference will now be made by way of example only to the accompanying drawings in which:

Fig 1 schematically illustrates an example of an apparatus 2 and its functional components;

15 Fig 2 schematically illustrates a delivery mechanism for a computer program;

Fig 3 illustrates one of many different examples of an apparatus;

Figs 4A and 4B illustrate bending peripheral portions of the apparatus backwards;

20 Figs 4C and 4D illustrate bending peripheral portions of the apparatus forwards;

Fig 4E illustrates an apparatus for which the peripheral portions contort differently dependent upon which side of the body the peripheral portion is located;

25 Figs 5A and 5B schematically illustrate an embodiment where a pivoting digit provide resilient user-deformation of the exterior surface of the body 20 which is interpreted as a joy-stick command;

Fig 6 schematically illustrates an embodiment where a tracing digit provides resilient user-deformation of the exterior surface of the body which is interpreted as a scrolling or browsing command;

30

### DETAILED DESCRIPTION OF VARIOUS EMBODIMENTS OF THE INVENTION

The Figures illustrate an apparatus 2. The apparatus 2 may comprise: a body 20 configured for resilient contortion from a neutral equilibrium shape by a user, the body 20 having an exterior surface 28 that resiliently contorts in response to user provision of a force F. The body defines, proximal to a perimeter 22 of a face 26 of the body 20, at least a first portion (e.g. 24B) of an exterior surface 28 of the apparatus 2 and a second portion (e.g. 24F) of the exterior surface 28 of the apparatus 2 that opposes the first portion across the face 26. User provision of a force 23A in a first direction results in a first contortion 25A of the exterior surface 28 and user provision of a force 23B in a second direction, opposite to the first direction, results in a second contortion 25B of the exterior surface 28. The apparatus 2 comprises electronic circuitry 16 including at least a processor 4 configured to provide consistent meaning across a plurality of different software applications 17 for user provision of a force 23A in the first direction to the first portion (e.g. 24B) of the exterior surface 28 and to provide consistent meaning across the plurality of software applications 17 for user provision of a force 23A in the first direction to the second portion (e.g. 24F) of the exterior surface 28.

As consistent meaning is provided for similar user contortions at similar portions across different applications, the apparatus 2 is easier to use. Consistent meaning implies a consistent effect in the context of the application such as, for example, consistent affirmation of an available option, consistent negation of an available option; or a consistent navigation command.

Contortion is the deformation of the body 20 by twisting and/or bending. The extent of distortion facilitated by the body 20 depends upon implementation. Resilient contortion implies that the body stays in its contorted state while held in that state and returns to its equilibrium shape when released.

5

An apparatus 2 may be a hand-portable electronic apparatus 2. It may, for example, be an apparatus sized to fit into a jacket pocket or be carried in the palm of a user's hand. The apparatus 2 may be a personal user device such as a mobile cellular telephone, a personal music player, a personal video player, a personal handheld computer, a personal digital assistant or similar.

Fig 1 schematically illustrates an example of the apparatus 2 and its functional components. In this example, the apparatus 2 not only comprises a display 14 and electronic circuitry 16 but also comprises sensors 12, a user input 10 and a user output 8.

The electronic circuitry 16 is configured to control the display 14 and user output 8. The electronic circuitry 16 is configured to receive input from the user input 10 and from the sensors 12.

The sensors 12 may be configured and positioned to detect contortions and other deformations of the body 20 by a user. The sensors 12 are configured to detect and enable disambiguation of different contortions of the body 20.

To disambiguate between contortions of different portions 24 it may be necessary to identify which portion(s) is/are most contorted or which portion(s) were first contorted. The sensors 12 may be configured to detect an extent and/or timing of contortion at a portion.

Contortion may include deformations such as bend, torsion, stretch, compression or applied tension such as compression, stretch, shearing, torque. The sensors 12 may, for example, include strain gauges, and force and touch sensors (capacitive, resistive, piezoelectric...).

The electronic circuitry 16 receives an input from the sensors 12, identifies the detected contortion (and perhaps its extent) and controls the operation of the

6

apparatus 2 in dependence upon the detected contortion (and perhaps its extent).

5 The user input 10 may comprise a device for tactile user input such as a touch screen for the display 14 or a key or keypad and/or it may comprise a device for audio user input such as a microphone.

10 The user output 10 may comprise a device for visual user input such as lights and/or it may comprise a device for audio user output such as a loudspeaker or headphone socket.

15 The electronic circuitry 16 may be implemented using instructions that enable hardware functionality, for example, by using executable computer program instructions in a general-purpose or special-purpose processor that may be stored on a computer readable storage medium (disk, memory etc) 6 to be executed by such a processor 4.

20 In the illustrated example, the electronic circuitry 16 comprises a processor 4 and a memory 6. The processor 4 is configured to read from and write to the memory 6. The processor 4 may also comprise an output interface via which data and/or commands are output by the processor 4 and an input interface via which data and/or commands are input to the processor 4.

25 The memory 6 stores a plurality of software applications 17. Each software application comprises code which when run by the processor 4 enables a software application. The user is able to provide input to each software application 17 by contorting portions of the apparatus. The meaning (effect) of a particular contortion (e.g. backwards bend) at a particular portion is consistent across the plurality of applications 17.

30

The memory 6 also stores a computer program 18 comprising computer program instructions that control the operation of the apparatus 2 when

7

loaded into the processor 4. The computer program instructions 18 provide the logic and routines that enables the apparatus to perform, for example, disambiguation of the inputs from the sensors 12 and to consequently control the apparatus 2 in dependence upon the detected contortions. The processor 2 by reading the memory 6 is able to load and execute the computer program 18.

Referring to Fig 2, the computer program 18 may arrive at the apparatus 2 via any suitable delivery mechanism 19. The delivery mechanism 19 may be, for example, a computer-readable storage medium, a computer program product, a memory device, a record medium such as a CD-ROM or DVD, an article of manufacture that tangibly embodies the computer program 18. The delivery mechanism may be a signal configured to reliably transfer the computer program 18, such as an over-the-air radio signal. The apparatus 2 may propagate or transmit the computer program 18 as a computer data signal.

Although the memory 6 is illustrated as a single component it may be implemented as one or more separate components some or all of which may be integrated/removable and/or may provide permanent/semi-permanent/dynamic/cached storage.

References to 'computer-readable storage medium', 'computer program product', 'tangibly embodied computer program' etc. or a 'controller', 'computer', 'processor' etc. should be understood to encompass not only computers having different architectures such as single /multi- processor architectures and sequential (Von Neumann)/parallel architectures but also specialized circuits such as field-programmable gate arrays (FPGA), application specific circuits (ASIC), signal processing devices and other devices. References to computer program, instructions, code etc. should be understood to encompass software for a programmable processor or firmware such as, for example, the programmable content of a hardware device

whether instructions for a processor, or configuration settings for a fixed-function device, gate array or programmable logic device etc.

Fig 3 and 4A to 4E illustrate an example of the apparatus 2. The apparatus 2  
5 comprises a body 20 configured for resilient contortion from a neutral equilibrium shape by a user. The body 20 has an exterior surface 28 that resiliently contorts in response to user actuation and defines at least part of an exterior surface 28 of the apparatus 2. The body may comprise a display 14 on at least a portion of the exterior surface 28 of the body 20. In this example,  
10 the display is controlled by electronic circuitry 16 (not illustrated) including at least a processor 4.

In the illustrated examples, the apparatus 2 is substantially rectangular with rounded corners and the apparatus 2 is used in a landscape orientation with  
15 the longest side of the rectangular body 20 extending between the left hand and the right hand of the user. However, different shapes of body may be used such as ellipsoid, circle, ovoid etc

The body 20 has an exterior surface 28 that resiliently contorts in response to  
20 user provision of a force F.

The body 20 has a face 26 which is presented to the user. In this example, the face 26 comprises a display 14 which may be flexible. For example, the display 14 may be configured for resilient contortion and may contort as the  
25 body contorts. Suitable displays may include organic light emitting diode (OLED) displays, polymer organic light emitting diode (P-OLED) displays, light emitting polymer (LEP) displays, flexible liquid crystal displays (e.g. cholesteric liquid crystal or polymer-dispersed liquid crystal), electrophoretic displays or electrowetting displays. In other examples, the display 14 may not  
30 be present.

The face 26 has a perimeter 22 and portions 24A-24H of the exterior surface 28 of the body 20 that can be contorted for user input are positioned adjacent the perimeter 22. In this example there is a labelled portion for each edge/vertex of the rectangular face 26. However, it should be appreciated that there may be more, or less distinct portions 24. For example, every vertex and edge may not have an associated distinct portion that can be contorted for user input. For example, an edge may have more than one associated distinct portion that can be contorted for user input at different locations along its length.

10

In the specific illustrated example, there is a top-right corner portion 24A positioned adjacent a top-right corner of the face 26. There is a right-edge portion 24B positioned adjacent a right-edge of the face 26. There is a bottom-right corner portion 24C positioned adjacent a bottom-right corner of the face 26. There is a bottom-edge portion 24D positioned adjacent a bottom-edge of the face 26. There is a bottom-left corner portion 24E positioned adjacent a bottom-left corner of the face 26. There is a left-edge portion 24F positioned adjacent a left-edge of the face 26. There is a top-left corner portion 24G positioned adjacent a top-left corner of the face 26. There is a top-edge portion 24H positioned adjacent a top-edge of the face 26.

20

Fig 4A illustrates that a user may provide a downward force 23A at any of the portions 24A-24H and thereby cause a backward bend 25A of the portion. This is interpreted as a user input by the electronic circuitry 16. The downward force 23A is provided by a user using the hand(s) holding the apparatus 2 without having to remove them from holding the apparatus 2. As an example, Fig 4B illustrates user provision, using a right-hand holding the apparatus, of a downward force 23A on a front face 26 at a right-edge portion 24B which causes a backward bend 25A of the portion 24B.

25

30

Fig 4C illustrates that a user may provide an upward force 23B at any of the portions 24A-24H and thereby cause a forward bend 25B of the portion. This

10

is interpreted as a user input by the electronic circuitry 16. The upward force 23B is provided by a user using the hand(s) holding the apparatus 2 without having to remove them from holding the apparatus 2. As an example, Fig 4D illustrates user provision, using a right-hand holding the apparatus, of an upward force 23B on a rear face (not illustrated) at a right-edge portion 24B which causes a forward bend 25B of the portion 24B.

In Figs 4A, 4B, 4C and 4D the direction of a force is illustrated using a convention borrowed from electromagnetism. A circle with a point at its centre represents a tip of an arrow and indicates that the force is out of the page. A circle with a cross at its centre represents a tail of an arrow and indicates that the force is into the page.

In Figs 4A, 4B, 4C and 4D the direction of a bend is illustrated using an arrow 25 in the plane of the paper that points along a negative gradient of the surface 28. It points towards the lower local potential energy state and indicates where a ball placed on the surface 28 would roll towards.

In Figs 4A, and 4C each and every portion 24A-24H is configured to be bent backwards and to be bent forwards. In some implementations a portion may be configured to be bent forward and not backward or configured to be bent forward and not backward.

In Figs 4A, and 4C bending backwards and bending forwards are used as examples of opposing contortions created using opposite forces. It should be appreciated that contortions other than bending forwards and backwards may be possible as additions or alternatives. Examples of pairs of opposing contortions may, for example, include twist clockwise or twist anti-clockwise or push-in and pull-out.

30

In the examples of Figs 4A to 4D, the electronic circuitry 16 is configured to provide consistent meaning across the plurality of different software

applications 17 for backward bending of a portion 24 of the exterior surface 2. Each backward-bent portion 24A-24H may be associated with meaning or effect that remains constant or similar for each software application 17. Thus a user action, such as bending a portion 24A forward will have similar effect  
5 irrespective of which of the different software applications 17 is currently running. This provides for intuitive operation of the apparatus 2.

In the examples of Figs 4A to 4D, the electronic circuitry 16 is also configured to provide consistent meaning across a plurality of different software  
10 applications 17 for forward bending of a portion 24 of the exterior surface 2. Each forward-bent portion 24A-24H may be associated with meaning or effect that remains constant or similar for each software application 17. Thus a user action, such as bending a portion 24A forward will have similar effect  
15 irrespective of which of the different software applications 17 is currently running. This provides for intuitive operation of the apparatus 2.

For example, backward bending of a particular portion may provide, in each of the plurality of software applications 17, an affirmative command and backward bending of a portion opposing the particular portion may provide, in  
20 each of the plurality of applications 17, a negative command.

The particular portion may, for example, be an edge portion 24B, 24D, 24F, 24H and the opposing portion may be an edge portion 24F, 24H, 24B, 24D on the opposite side of the face 28.  
25

The particular portion may, for example, be a corner portion 24A, 24C, 24E, 24G and the opposing portion may be a non-adjacent corner portion 24E, 24G, 24A, 24C that is diagonally opposing across the rectangular face 28.

30 The particular portion may, for example, be a corner portion 24A, 24C, 24E, 24G and the opposing portion may be an adjacent corner portion 24C, 24E, 24G, 24A that is opposing across an edge of the rectangular face 28.

An affirmative command may result in advancement, for example, through a menu system or in a direction determined by a location of the particular portion.

5

A negative command may result in retreat, for example, through a menu system or in a direction determined by a location of the opposing portion.

In some examples, forward bending of the particular portion may provide, in each of the plurality of software applications, the negative command and forward bending of the opposing portion may provide, in each of the plurality of applications, the affirmative command.

According to one embodiment, backward bending of a portion 24 may provide, in the plurality of software applications, an affirmative pre-selection navigation command consistent with a location of the portion 24. The portion 24 is located relative to an origin a centre of the face 26 along a vector and the affirmative pre-selection navigation command navigates in a direction of the vector. In some examples, forward bending of the portion may provide, in the plurality of software applications, a negative navigation command consistent with a location of the portion. The negative pre-selection navigation command navigates in a direction opposite to the vector.

The navigation commands associated with the different portions 24 may enable, in the software applications, one or more of: navigating through a hierarchical menu structure; scrolling; panning; and positioning a pointer.

For example, the following table illustrates how a user can input different navigation commands by bending different portions 24A-24H.

30

<b>Portion</b>	<b>Bend</b>	<b>Navigation</b>
Top edge 24H	Back	up

Top edge 24H	Forward	down
Bottom edge 24D	Back	down
Bottom edge 24D	Forward	up
Right edge 24B	Back	right
Right edge 24B	Forward	left
Left edge 24B	Back	left
Left edge 24B	Forward	right
Top-right corner 24A	Back	diagonal towards top-right
Top-right corner 24A	Forward	diagonal towards bottom-left (away from top-right)
Bottom-right corner 24C	Back	diagonal towards bottom-right
Bottom-right corner 24C	Forward	diagonal towards top-left (away from bottom-right)
Top-left corner 24G	Back	diagonal towards top-left
Top-left corner 24G	Forward	diagonal towards bottom-right (away from top-left)
Bottom-left corner 24E	Back	diagonal towards bottom-left
Bottom-left corner 24E	Forward	diagonal towards top-right ( away from bottom-left)

Table 1

5 An affirmative command input by backward bending the particular portion may consistently complete an action defined by an in-use one of the software applications and a subsequent downward bend of an opposing portion may consistently provide an affirmative command that at least partially undoes the completed action.

For example, the affirmative command:

Top edge 24H	Back	up
--------------	------	----

10 may be consistently undone, irrespective of software application, by the affirmative command

Bottom edge 24D	Back	down
-----------------	------	------

5 An affirmative command input by backward bending the particular portion may provide the same command as a negative command input by forward bending the opposing portion.

For example, the affirmative command:

Top edge 24H	Back	up
--------------	------	----

may be consistently the same, irrespective of software application, as the negative command

Bottom edge 24D	Forward	up
-----------------	---------	----

10 and may be consistently opposite, irrespective of software application, as the associated affirmative command

Bottom edge 24D	Back	down
-----------------	------	------

15 If a particular portion and its opposing portion are simultaneously used to provide contradictory commands, that is they are bent in the same direction, then a third meaning can be consistently assigned to this contortion that is different to the meaning consistently assigned to the particular portion when bent in that direction and different to the meaning consistently assigned to the opposing portion when bent in that direction.

20

For example, the affirmative command:

Right edge 24B	Back	right
----------------	------	-------

and the affirmative command

Left edge 24F	Back	left
---------------	------	------

25 when performed together may provide consistently, irrespective of software application, a different command

Right edge 24B & Left edge 24F	Both back	select or zoom-out
--------------------------------	-----------	--------------------

For example, the negative command:

Right edge 24B	Forward	left
----------------	---------	------

and the negative command

Left edge 24F	Forward	right
---------------	---------	-------

5

when performed together may provide consistently, irrespective of software application, a different command

Right edge 24B & Left edge 24F	Both forward	de-select or zoom-in
--------------------------------	--------------	----------------------

10

Fig 4E illustrates an apparatus 2 for which the portions 24A-24H contort differently dependent upon which side of the body the portion is located. As previously described the number, location and contortions described for the portions 24A-24H are only examples.

15

In the illustrated example, the apparatus 2 has portions 24A, 24B, 24C, 24D and 24H on the right-hand side 31 adjacent the right-side perimeter 22 of the face 26 of the body 20. The apparatus 2 has portions 24E, 24F, 24G, on the left-hand side 33 adjacent the left-side perimeter 22 of the face 26 of the body 20.

20

The electronic circuitry is configured to provide a first functions in response to backward bending 25B of the right-side portions and a second different function in response to backward bending 25B of the left-side portion(s).

25

The right-side portions may be contorted as part of a global contortion of the whole apparatus 2. The right side portions include the top edge 24H, the

bottom edge 24D and the right-side edge 24C. They may also include the top-right corner 24A and the bottom-right corner 24C.

5 The right-side portions may be used for pre-selection navigation control as described in the table 1 above. The right-side portions may, for example, provide the functionality of an analog joystick.

10 Bending down a right-side portion navigates in a direction of a vector defined by the location of that portion. For example, bending the right edge 24B back may navigate right, bending the right edge 24B forward may navigate left, bending top edge 24H back may navigate up, bending the top edge 24H forward may navigate down, bending the bottom edge 24D back may navigate down and bending the bottom edge 24D up may navigate up.

15 The left-side portion(s) may be contorted as part of a local contortion and not as part of a global contortion of the whole apparatus 2. The left side portion(s) include the left edge 24F. They may also include the top-left corner 24G and the bottom-left corner 24E. The left-side portion may, for example, comprise a rim contorted by bending the rim.

20

The left-side portion(s) may be used for post-navigation selection.

25 User provision of a force in a first direction to any of the right-side portions results in a first contortion of the exterior surface 28 to a different extent than user provision of the same force in the first direction to the left-side portion(s). That is the compliance of the portions may be different depending upon location.

30 The apparatus 2 may be rotatable such that the right-side portions are positioned for use by a user's left-hand in providing the first functions and the left-side portion(s) is positioned for use by a user's right-hand in providing the second function. For example, there may be a detector (e.g. a gyroscope or

accelerometer, for example) that detects the orientation of the apparatus and adjusts output on the display accordingly and interprets input from the user via contortion of the apparatus 2 accordingly. It will, for example, be appreciated that the mappings of particular deformations to commands are inverted so that, for the deformations, 'top' exchanges with 'bottom' and 'left' exchanges with 'right' when the apparatus is rotated through 180 degrees.

Figs 5A, 5B and 6 schematically illustrate embodiments where the body 20 is configured for resilient user-deformation of the exterior surface 28 of the body 20. The body 20 may be as illustrated in Figs 3A to 3G and Figs 4A and 4B or it may be different, such as the body 20 illustrated in Figs 7A and 7B. The sensors 12 are configured to detect a time varying user-defined deformation of the exterior surface 28 of the body 20.

The Figs 5A, 5B and 6 schematically illustrate embodiments where the body 20 is configured at portions 24 for resilient user-deformation of the exterior surface 28 of the body 20 by a digit 32. The user digit contacts the exterior surface 28 of the body 20 which deforms to form a depression 30. The contact defines a contact area 34. The sensors 12 are configured to detect a motion of the contact area 34 as a user input command.

In Figs 5A and 5B, the user pivots the digit 32 about its point of contact. As the digit pivots downwards reducing the contact angle between the digit and the exterior surface 28, the contact area 34 changes shape and typically increases in size. The sensors 12 are configured to detect a dynamic change in the contact area and interpret it as an input joy-stick command where the digit 32 is the joy-stick.

In Fig 6, the user traces the digit 32 along the exterior surface 28 while still creating the depression 30. As the digit moves the contact area 34 changes position. The sensors 12 are configured to detect a dynamic change in the

18

position of the contact area 34 and interpret it as an input scrolling or browsing command.

5 Although embodiments of the present invention have been described in the preceding paragraphs with reference to various examples, it should be appreciated that modifications to the examples given can be made without departing from the scope of the invention as claimed.

10 Features described in the preceding description may be used in combinations other than the combinations explicitly described.

Although functions have been described with reference to certain features, those functions may be performable by other features whether described or not.

15

Although features have been described with reference to certain embodiments, those features may also be present in other embodiments whether described or not.

20 Whilst endeavoring in the foregoing specification to draw attention to those features of the invention believed to be of particular importance it should be understood that the Applicant claims protection in respect of any patentable feature or combination of features hereinbefore referred to and/or shown in the drawings whether or not particular emphasis has been placed thereon.

25

I/we claim:

30

## CLAIMS

1. An apparatus comprising:  
a body configured for resilient contortion from a neutral equilibrium shape by a  
5 user, the body having an exterior surface that resiliently contorts in response  
to user provision of a force, wherein the body defines, proximal to a perimeter  
of a face of the body, at least a first portion of an exterior surface of the  
apparatus and a second portion of an exterior surface of the apparatus that  
10 opposes the first portion across the face, wherein user provision of a force in  
a first direction results in a first contortion of the exterior surface and user  
provision of a force in a second direction, opposite to the first direction, results  
in a second contortion of the exterior surface; and  
electronic circuitry including at least a processor configured to provide  
15 consistent meaning across a plurality of different software applications  
for user provision of a force in the first direction to the first portion of the  
exterior surface and to provide consistent meaning across the plurality of  
software applications for user provision of a force in the first direction to the  
second portion of the exterior surface.
- 20 2. An apparatus as claimed in claim 1, wherein a first contortion of the first  
portion provides, in the plurality of software applications, a command for  
advancement and wherein a first contortion of the second portion provides, in  
the plurality of applications, a command for retreat.
- 25 3. An apparatus as claimed in claim 1 or 2, wherein a first contortion of the  
first portion provides, in the plurality of software applications, a navigation  
command consistent with a location of the first portion and wherein a first  
contortion of the second portion provides, in the plurality of software  
30 applications, a navigation command consistent with a location of the second  
portion.

20

4. An apparatus as claimed in claim 3, wherein the navigation commands enable, in the software applications, one or more of:

navigating through a hierarchical menu structure;

scrolling;

5 panning; and

positioning a pointer.

5. An apparatus as claimed in any preceding claim, wherein a first contortion of the first portion consistently provides, in the plurality of software

10 applications, a command that completes an action defined by an in-use one of the software applications and a subsequent first contortion of the second portion consistently provides a command that at least partially undoes the completed action.

15 6. An apparatus as claimed in any preceding claim, wherein user provision of a force in a first direction to the first portion of the exterior surface results in a backward bending of the first portion;

wherein user provision of a force in a first direction to the second portion of the exterior surface results in a backward bending of the second portion;

20 wherein user provision of a force in a second direction to the first portion of the exterior surface results in a forward bending of the first portion; and

wherein user provision of a force in the second direction to the second portion of the exterior surface results in a forward bending of the second portion.

25 7. An apparatus as claimed in any preceding claim, wherein the first portion is an edge portion and the second portion is an edge portion .

8. An apparatus as claimed in any of claims 1 to 5, wherein the first portion is a corner portion and the second portion is an adjacent corner portion or a  
30 non- adjacent corner portion.

9. An apparatus as claimed in any preceding claim, wherein the electronic circuitry is configured to provide consistent meaning across a plurality of different software applications for user provision of a force in the second direction to the first portion of the exterior surface and to provide consistent  
5 meaning across the plurality of software applications for user provision of a force in the second direction to the second portion of the exterior surface.

10. An apparatus as claimed in any preceding claim, wherein the electronic circuitry is configured to provide consistently a common meaning across a  
10 plurality of different software applications for user provision of a force in the first direction to the first portion of the exterior surface and user provision of a force in the second direction to the second portion of the exterior surface.

11. An apparatus as claimed in any preceding claim, wherein the electronic  
15 circuitry is configured to provide consistently a common meaning across a plurality of different software applications for user provision of a force in the first direction to the second portion of the exterior surface and user provision of a force in the second direction to the first portion of the exterior surface.

20 12. An apparatus as claimed in any preceding claim, wherein the electronic circuitry is configured to provide consistent meaning across a plurality of different software applications in response to simultaneous user provision of a force in the first direction to the first portion of the exterior surface and a force in the first direction to the second portion of the exterior surface.

25 13. An apparatus as claimed in any preceding claim, wherein the electronic circuitry is configured to provide consistent meaning across a plurality of different software applications in response to simultaneous user provision of a force in the second direction to the first portion of the exterior surface and a  
30 force in the second direction to the second portion of the exterior surface

14. An apparatus as claimed in any preceding claim, wherein the electronic circuitry is configured to provide consistent meaning across a plurality of different software applications for simultaneous user provision of a force in the first direction to the first portion of the exterior surface and a force in the first direction to the second portion of the exterior surface and to provide the same consistent meaning across the plurality of different software applications for simultaneous user provision of a force in the second direction to the first portion of the exterior surface and a force in the second direction to the second portion of the exterior surface.

5  
10

15. An apparatus as claimed in claim 12, wherein the consistent meaning across a plurality of different software applications for simultaneous user provision of a force in the first direction to the first portion of the exterior surface and a force in the first direction to the second portion of the exterior surface is different to

15

the consistent meaning across a plurality of different software applications for user provision of a force in the first direction only to the first portion of the exterior surface;

20

the consistent meaning across the plurality of applications for user provision of a force in the first direction only to the second portion of the exterior surface;

25

the consistent meaning across a plurality of different software applications for user provision of a force in the second direction only to the first portion of the exterior surface; and

the consistent meaning across the plurality of applications for user provision of a force in the second direction only to the second portion of the exterior surface.

30

16. An apparatus as claimed in claim 15, wherein the consistent meaning across the plurality of different software applications for simultaneous user provision of a force in the first direction to the first portion of the exterior

surface and a force in the first direction to the second portion of the exterior surface is selection.

5 17. An apparatus as claimed in claim 15 or 16, wherein the consistent meaning across a plurality of different software applications for user provision of a force in the first direction to the first portion of the exterior surface, the consistent meaning across the plurality of applications for user provision of a force in the first direction to the second portion of the exterior surface, the consistent meaning across a plurality of different software applications for  
10 user provision of a force in the second direction to the first portion of the exterior surface, and the consistent meaning across the plurality of applications for user provision of a force in the second direction to the second portion of the exterior surface is pre-selection navigation.

15 18. An apparatus as claimed in any preceding claim, wherein the first portion is displaced relative to an origin along a first vector and the second portion displaced relative to an origin along a second vector, wherein user provision of a force in the first direction to the first portion of the exterior surface navigates in a direction of the first vector and user provision of a force in the  
20 first direction to the second portion of the exterior surface navigates in a direction of the second vector.

19. An apparatus as claimed in claim 18, wherein the first portion is a first edge and the second portion is a second different edge, wherein the first edge and the second edge are a pair of edges from a group comprising: left edge,  
25 top edge, bottom edge, right edge.

20. An apparatus as claimed in claim 19, wherein bending the right edge back navigates right; and/or wherein bending the right edge forward navigate left;  
30 and/or wherein bending top edge back navigates up; and/or wherein bending the bottom edge forward navigates down; and/or wherein bending the bottom

24

edge back navigates down; and/or wherein bending the bottom edge up navigates up.

5 21. An apparatus as claimed in any preceding claim, comprising sensors configured to detect an extent and/or timing of contortion.

22. An apparatus as claimed in any preceding claim sized as a hand-portable apparatus.

10 23. An apparatus as claimed in any preceding claim further comprising a flexible display.

24. An apparatus as claimed in any preceding claim further comprising a touch screen display.

15

25. An apparatus as claimed in any preceding claim comprising:  
wherein the body has an exterior surface that resiliently contorts in response to user provision of a force but contorts differentially dependent upon which side of the body the force is provided;

20 wherein the body defines, proximal to a first portion of a perimeter of a first side of a face of the body, first portions of an exterior surface of the apparatus and defines, proximal to a second portion of the perimeter of a second side of the face of the body, at least a second portion of an exterior surface of the apparatus ;

25 wherein user provision of a force in a first direction to any of the first portions results in a first contortion of the exterior surface to a different extent than user provision of the same force in the first direction to the second portion;  
and

30 wherein the electronic circuitry is configured to provide different functions in response to user provision of a force in a first direction to the first portions and user provision of the same force in the first direction to the second portion.

26. An apparatus comprising:

a body configured for resilient contortion from a neutral equilibrium shape by a user, the body having an exterior surface that resiliently contorts in response to user provision of a force but contorts differentially dependent upon which  
5 side of the body the force is provided;

wherein the body defines, proximal to a first portion of a perimeter of a first side of a face of the body, first portions of an exterior surface of the apparatus and defines, proximal to a second portion of the perimeter of a second side of the face of the body, at least a second portion of an exterior surface of the  
10 apparatus ;

wherein user provision of a force in a first direction to any of the first portions results in a first contortion of the exterior surface to a different extent than user provision of the same force in the first direction to the second portion;  
and

15 electronic circuitry including at least a processor configured to provide a first function in response to user provision of a force in a first direction to the first portions and to provide a second function in response to user provision of the same force in the first direction to the second portion.

20 27. An apparatus as claimed in claim 26, wherein the first portions are positioned for use by a user's right-hand in providing the first function and the second portion is positioned for use by a user's left-hand in providing the second function.

25 28. An apparatus as claimed in claim 26 or 27, wherein the apparatus is rotatable such that the first portions are positioned for use by a user's left-hand in providing the first function and the second portion is positioned for use by a user's right-hand in providing the second function.

30 29. An apparatus as claimed in claim 26, 27 or 28, wherein the first portions provide for pre-selection navigation control.

26

30. An apparatus as claimed in claim 26, 27, 28 or 29, wherein the first portions provide functionality of an analog joystick.

5 31. An apparatus as claimed in any of claims 26 to 30, wherein the first portions are configured to be contorted as part of a global contortion of the whole apparatus.

32. An apparatus as claimed in any of claims 26 to 31, wherein the first portions include a top edge, a bottom edge, and a side edge.

10

33. An apparatus as claimed in claim 32, wherein the side edge is a right edge and bending the right edge back navigates right.

15 34. An apparatus as claimed in claim 32 or 33, wherein the side edge is a right edge and bending the right edge forward navigates left.

35. An apparatus as claimed in any of claims 32 to 34, wherein bending top edge back navigates up.

20 36. An apparatus as claimed in any of claims 32 to 35, wherein bending the bottom edge forward navigates down.

37. An apparatus as claimed in any of claims 32 to 36, wherein bending the bottom edge back navigates down.

25

38. An apparatus as claimed in any of claims 32 to 37, wherein bending the bottom edge up navigates up.

30 39. An apparatus as claimed in any of claims 26 to 38, wherein the second portion is configured to be contorted as part of a local contortion of a part of the apparatus as opposed to a global contortion of the whole apparatus.

27

40. An apparatus as claimed in any of claims 26 to 39, wherein the second portion provides for post-navigation selection.

5 41. An apparatus as claimed in any of claims 26 to 40, wherein the second portion is at a rim.

42. An apparatus as claimed in claim 41, wherein the second portion is contorted by bending the rim.

10 43. An apparatus as claimed in any of claims 26 to 42, sized as a hand-portable apparatus.

44. An apparatus as claimed in any of claims 26 to 43, further comprising a flexible display.

15

45. An apparatus as claimed in any of claims 26 to 44, further comprising a touch screen display.

46. An apparatus comprising:

20 a body configured for resilient contortion from a neutral equilibrium shape, the body having an exterior surface that resiliently contorts in response to provision of a force, wherein the body defines, proximal to a perimeter of a face of the body, at least a first portion of an exterior surface of the apparatus and a second portion of an exterior surface of the apparatus that opposes the  
25 first portion across the face, wherein provision of a force in a first direction results in a first contortion of the exterior surface and provision of a force in a second direction, opposite to the first direction, results in a second contortion of the exterior surface; and

30 electronic circuitry including at least a processor configured to provide consistent meaning across a plurality of different software applications for provision of a force in the first direction to the first portion of the exterior surface and to provide consistent meaning across the plurality of software

applications for provision of a force in the first direction to the second portion of the exterior surface.

47. An apparatus comprising:

- 5 a body configured for resilient manual contortion from a neutral equilibrium shape, the body having an exterior surface that resiliently contorts in response to manual provision of a force, wherein the body defines, proximal to a perimeter of a face of the body, at least a first portion of an exterior surface of the apparatus and a second portion of an exterior surface of the apparatus
- 10 that opposes the first portion across the face, wherein manual provision of a force in a first direction results in a first contortion of the exterior surface and manual provision of a force in a second direction, opposite to the first direction, results in a second contortion of the exterior surface; and
- 15 electronic circuitry including at least a processor configured to provide consistent meaning across a plurality of different software applications for manual provision of a force in the first direction to the first portion of the exterior surface and to provide consistent meaning across the plurality of software applications for manual provision of a force in the first direction to the second portion of the exterior surface.

20

25

30

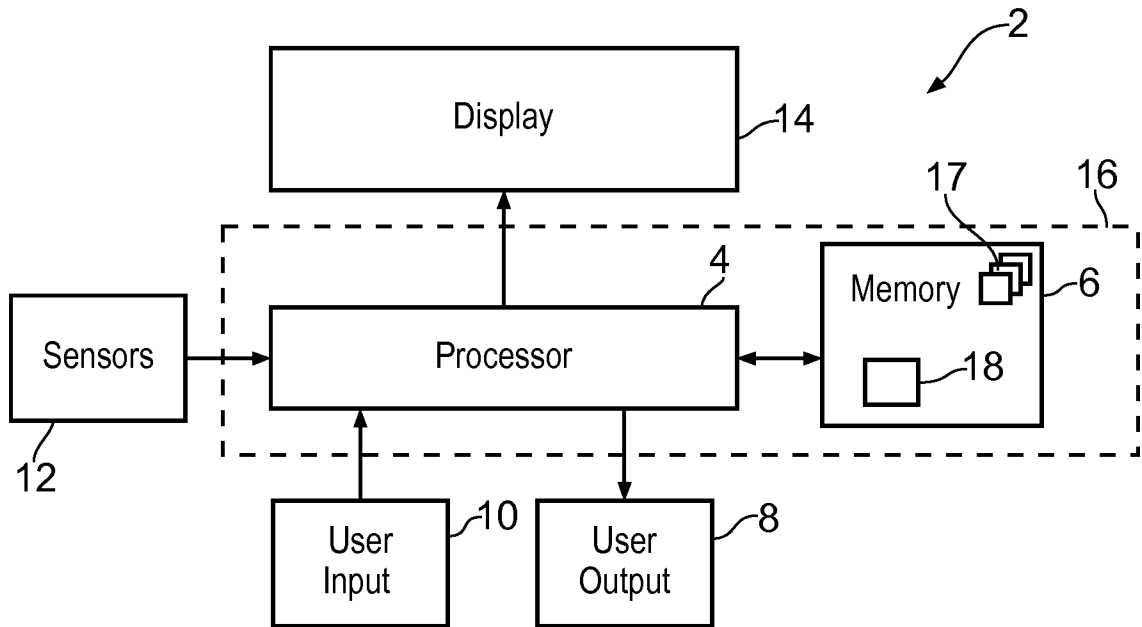

FIG. 1

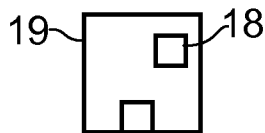

FIG. 2

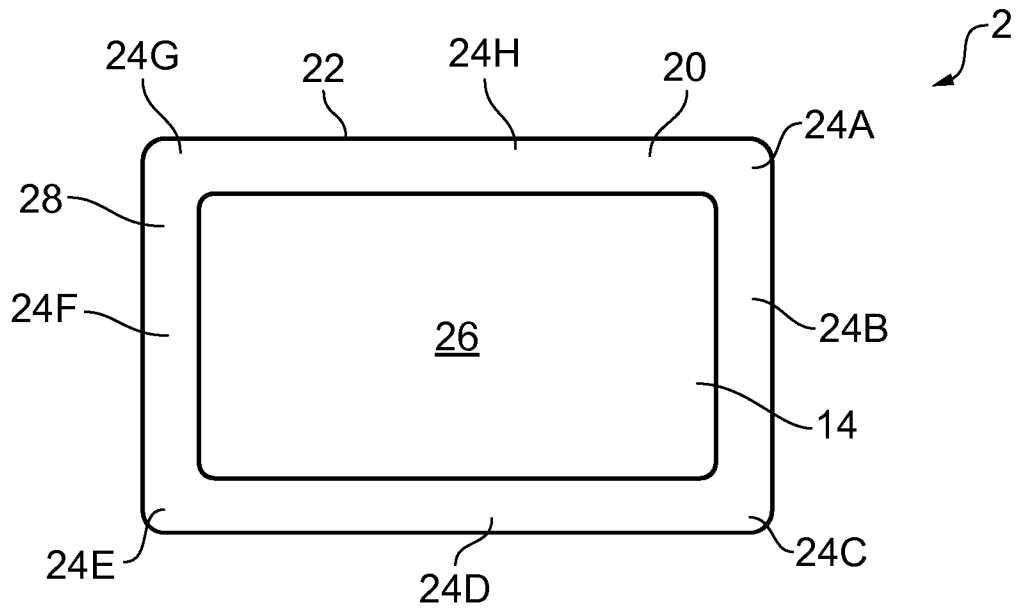

FIG. 3

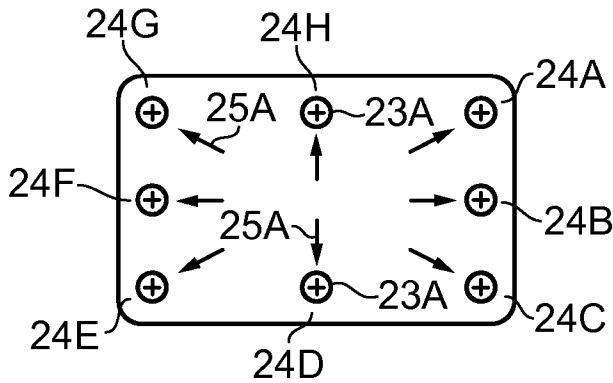

FIG. 4A

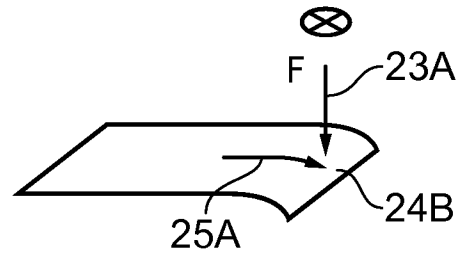

FIG. 4B

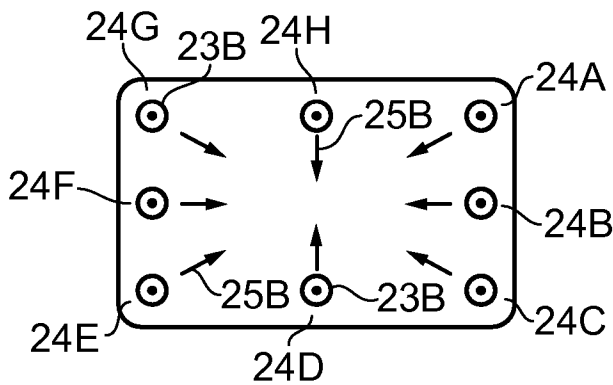

FIG. 4C

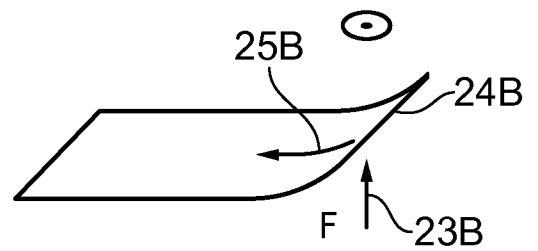

FIG. 4D

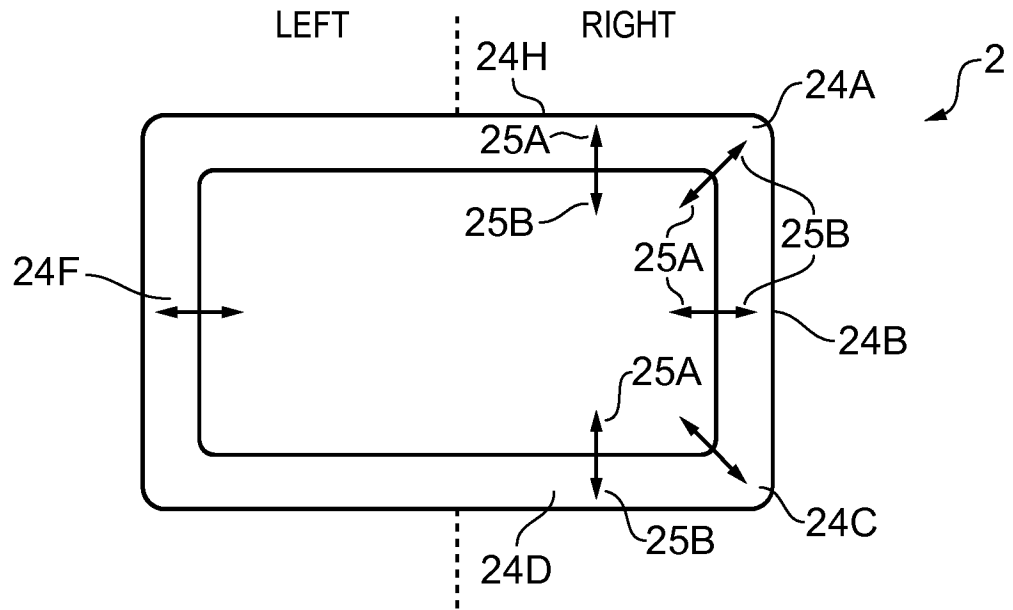

FIG. 4E

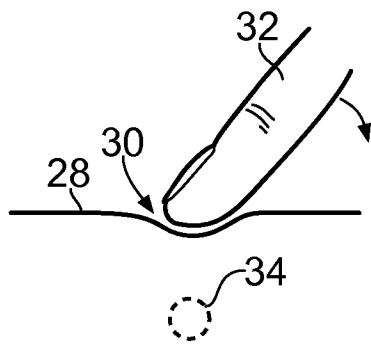

FIG. 5A

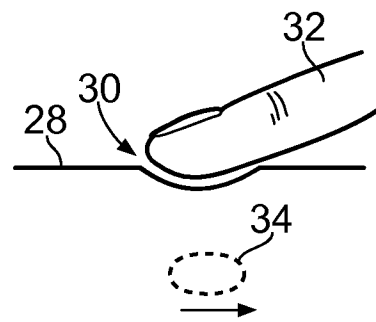

FIG. 5B

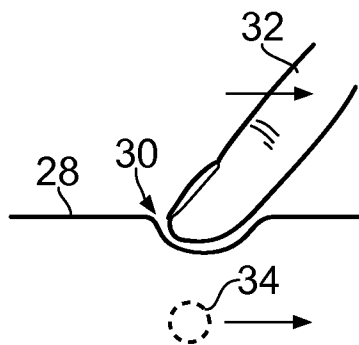

FIG. 6