



US 20070114235A1

(19) **United States**

(12) **Patent Application Publication**
Neasham et al.

(10) **Pub. No.: US 2007/0114235 A1**

(43) **Pub. Date: May 24, 2007**

(54) **FOOD SUPPORT DEVICE**

Publication Classification

(76) Inventors: **Cathryn Neasham**, Marietta, GA (US);
Brad Kofoed, Walnut Creek, CA (US)

(51) **Int. Cl.**
A47G 19/00 (2006.01)

Correspondence Address:
WEST & ASSOCIATES, A PC
2815 MITCHELL DRIVE
SUITE 209
WALNUT CREEK, CA 94598 (US)

(52) **U.S. Cl.** **220/574**

(57) **ABSTRACT**

(21) Appl. No.: **11/532,901**

(22) Filed: **Sep. 18, 2006**

Related U.S. Application Data

(60) Provisional application No. 60/737,935, filed on Nov. 18, 2005.

A food support device that serves to prevent melting frozen food from running onto the hands (and shirts, pants, shoes, etc.) of the consumer. The described apparatus can be adapted to receive and/or selectively engage various food items and capture any melted food and/or drippings from the food.

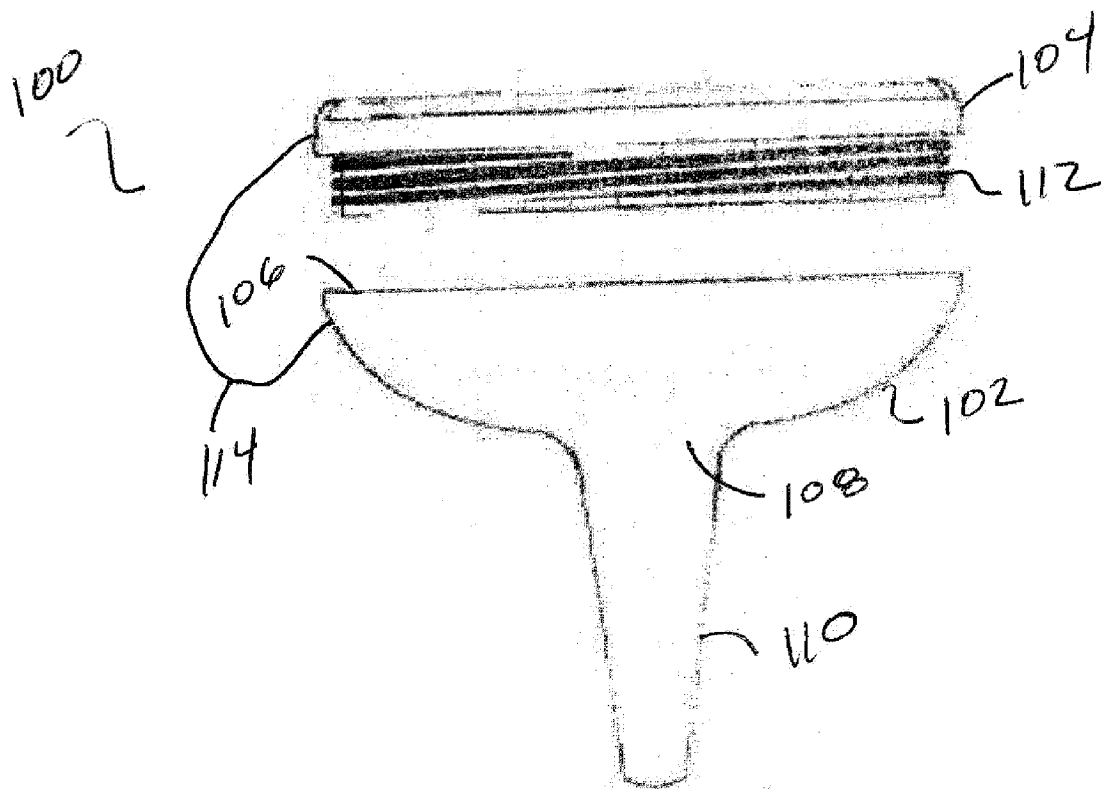

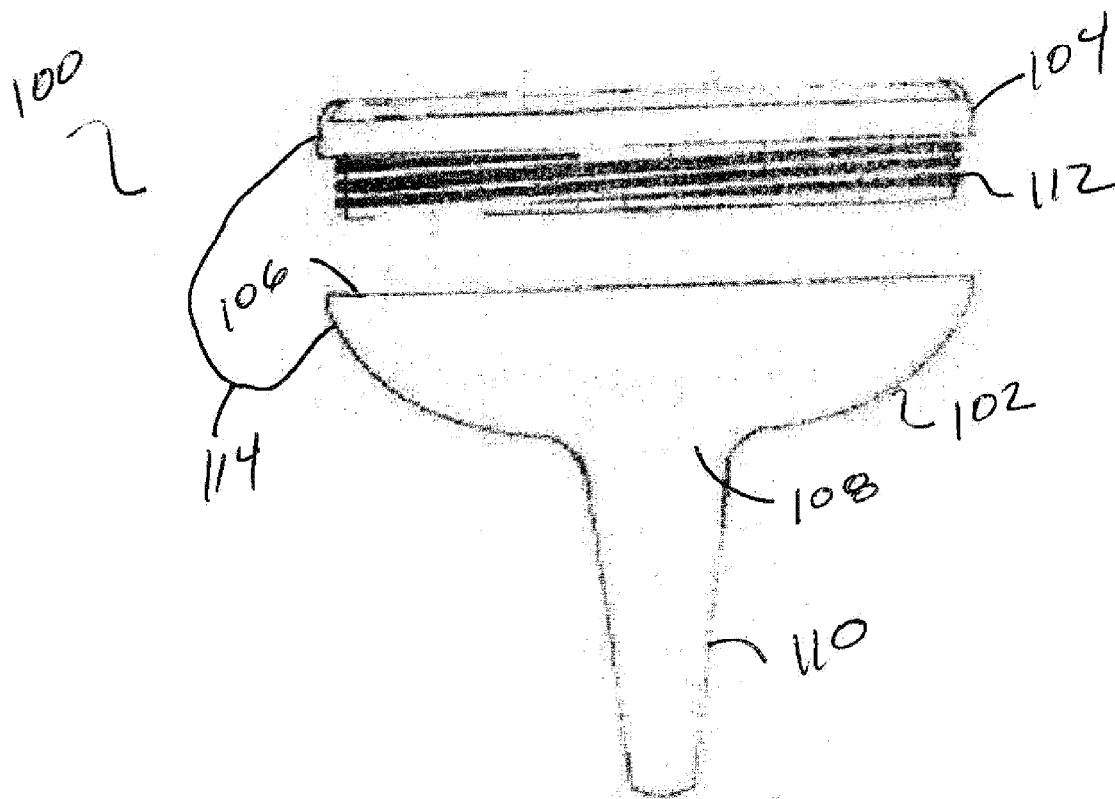

FIG. 1

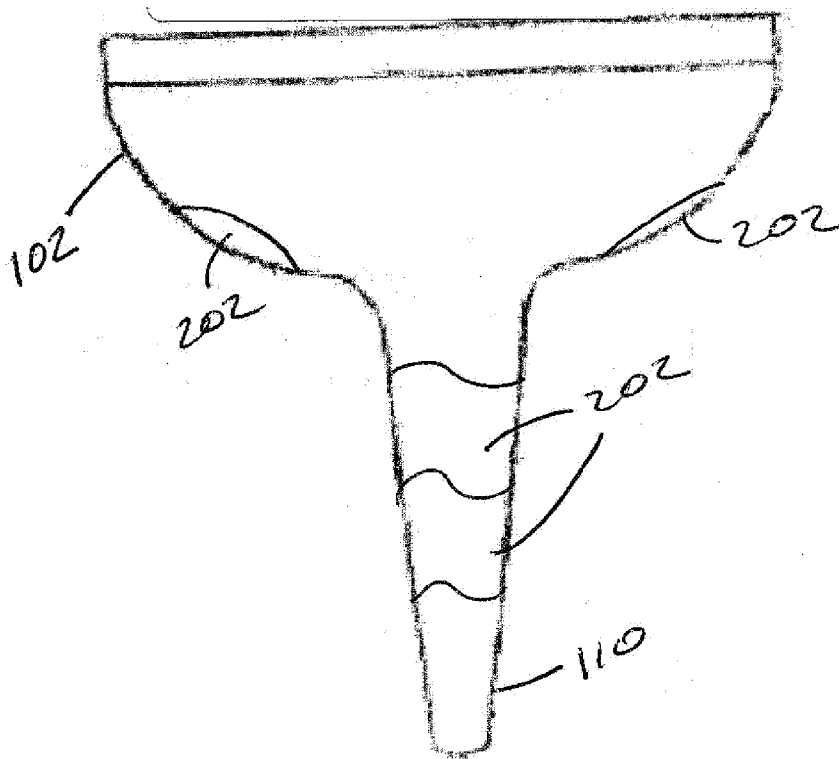

FIG. 2A

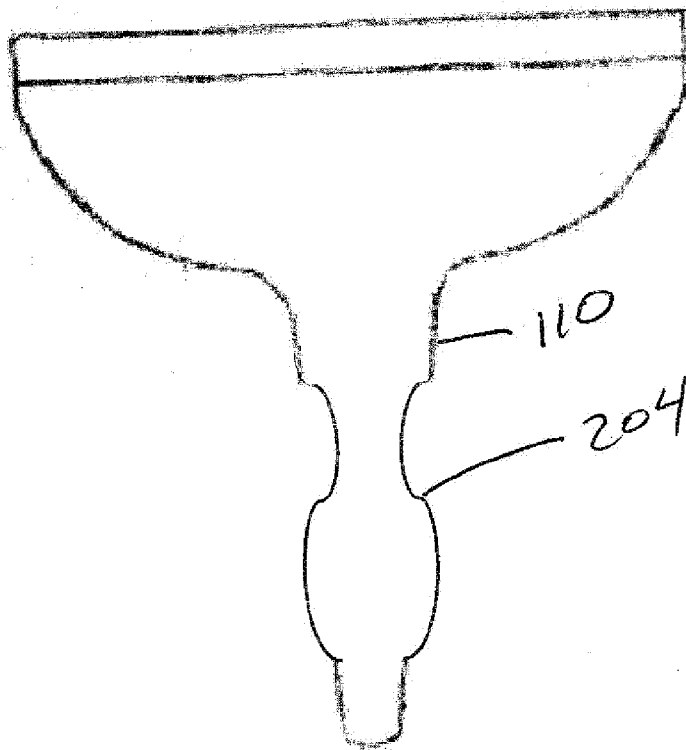

FIG. 2B

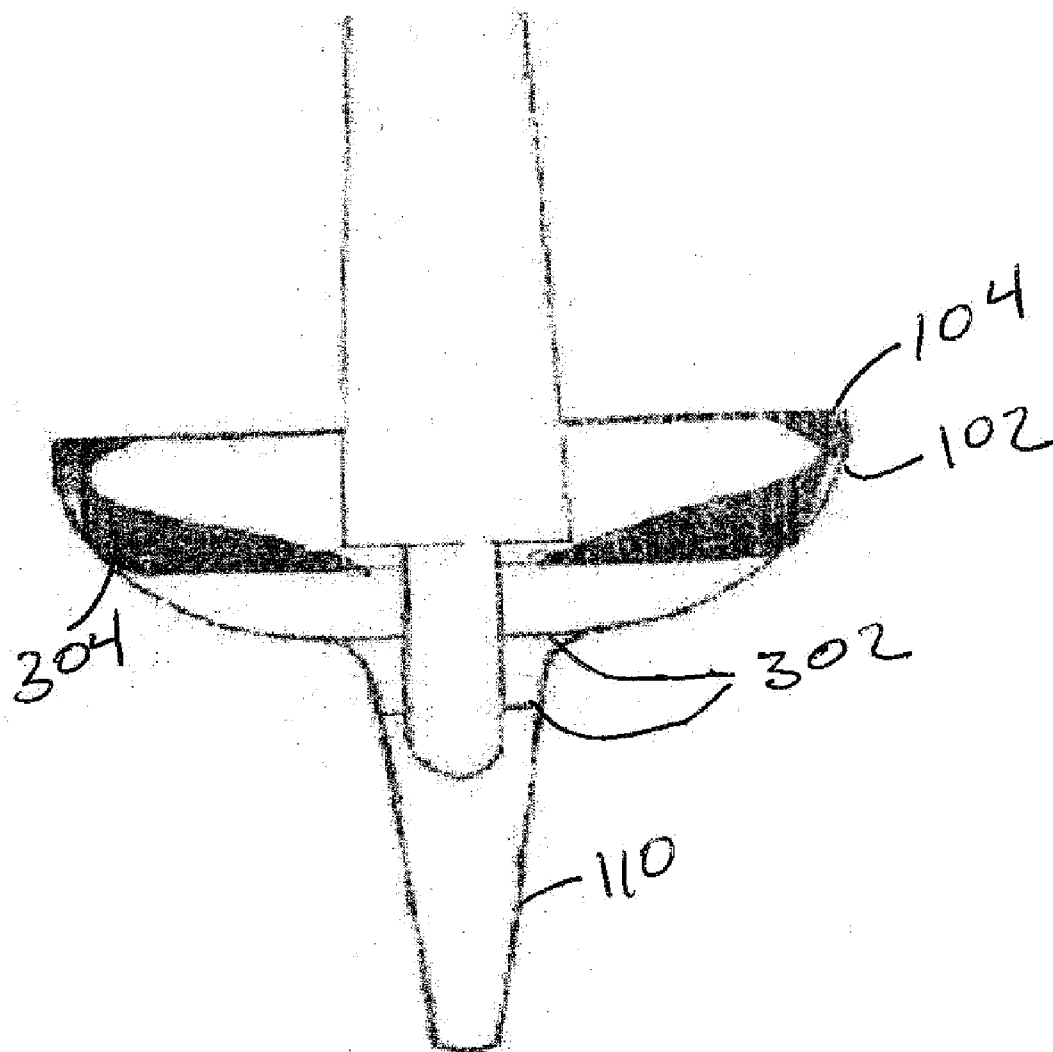

FIG. 3

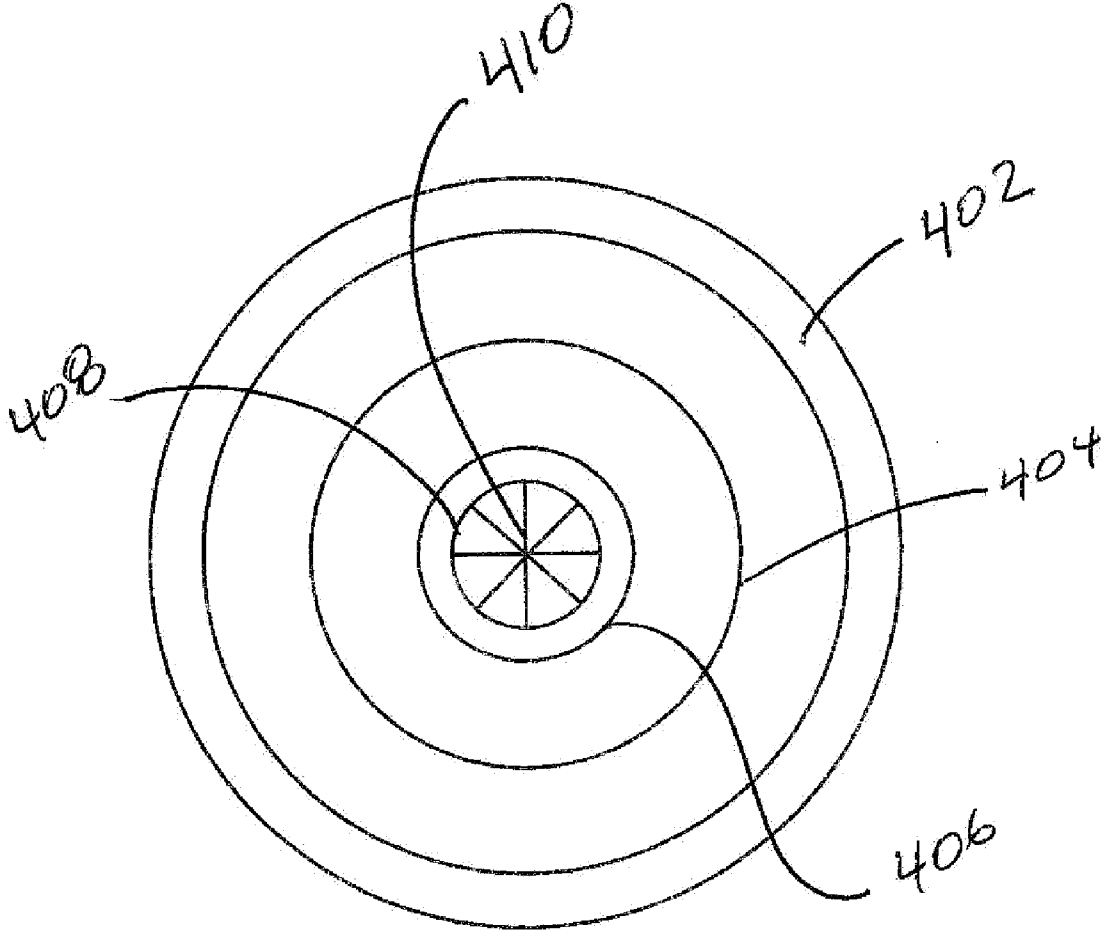

FIG. 4

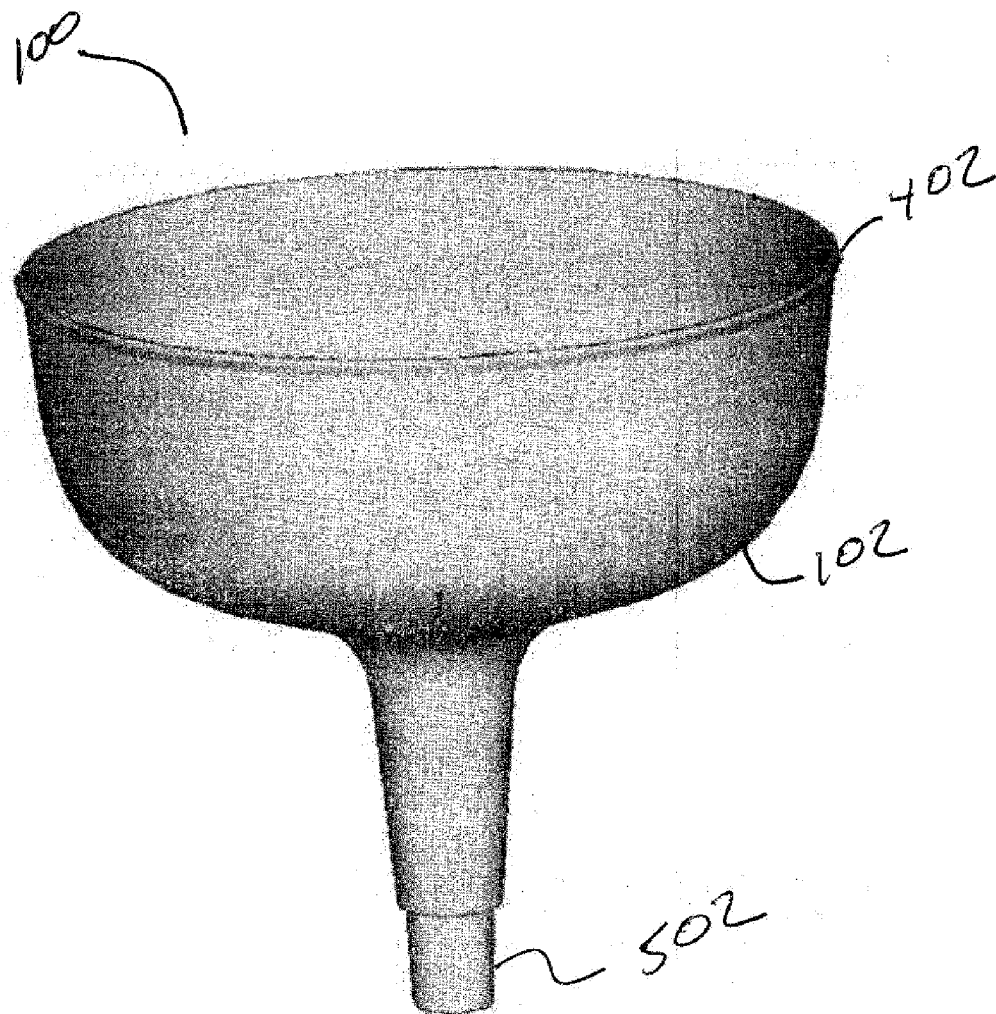

FIG. 5

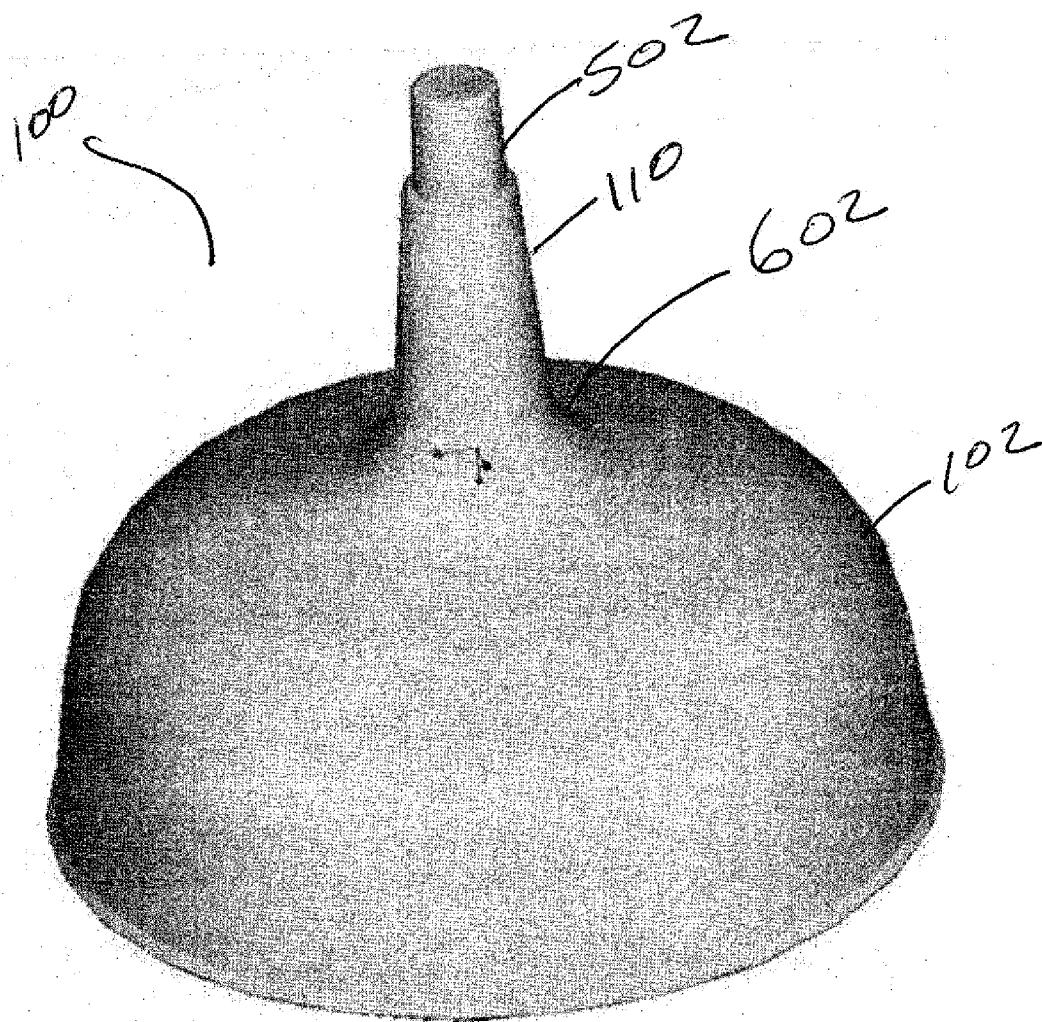

FIG. 6

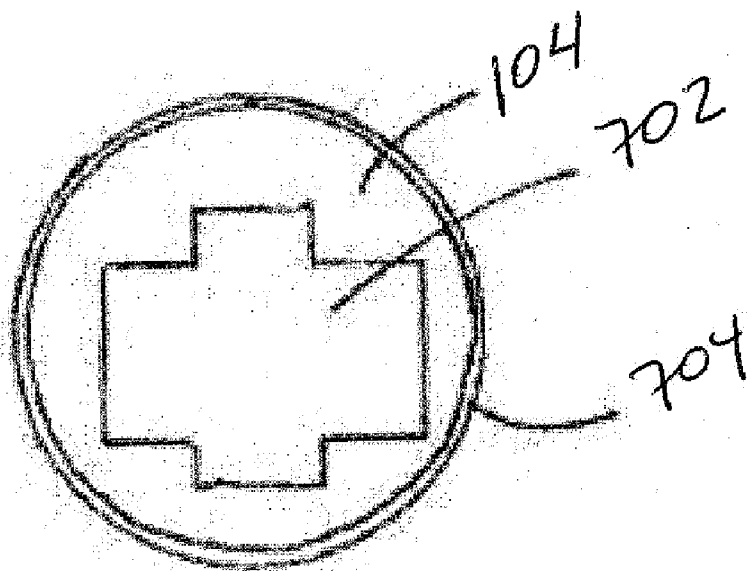

FIG. 7

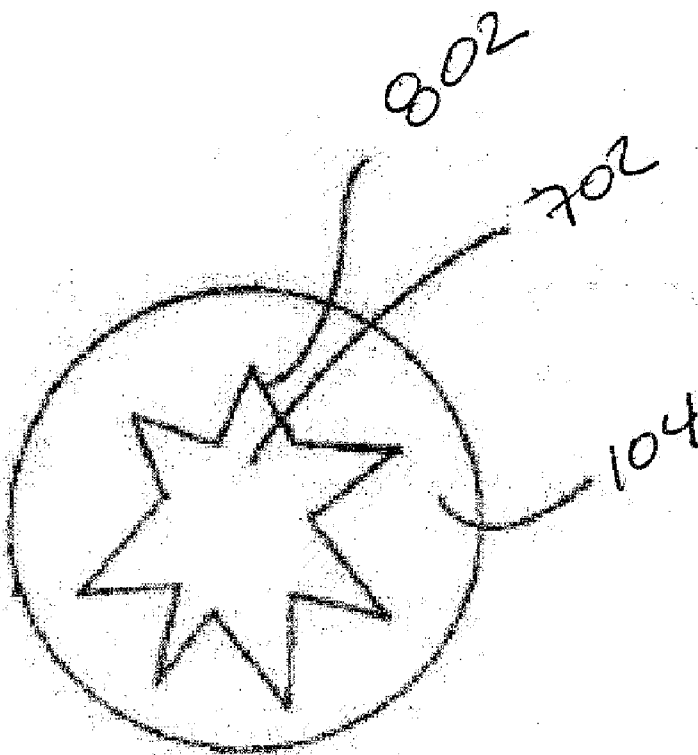

FIG. 8

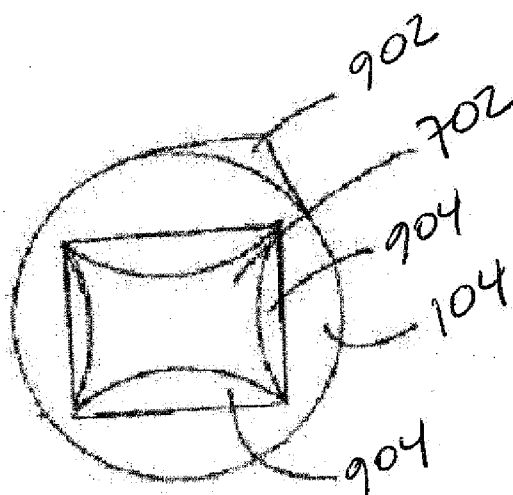
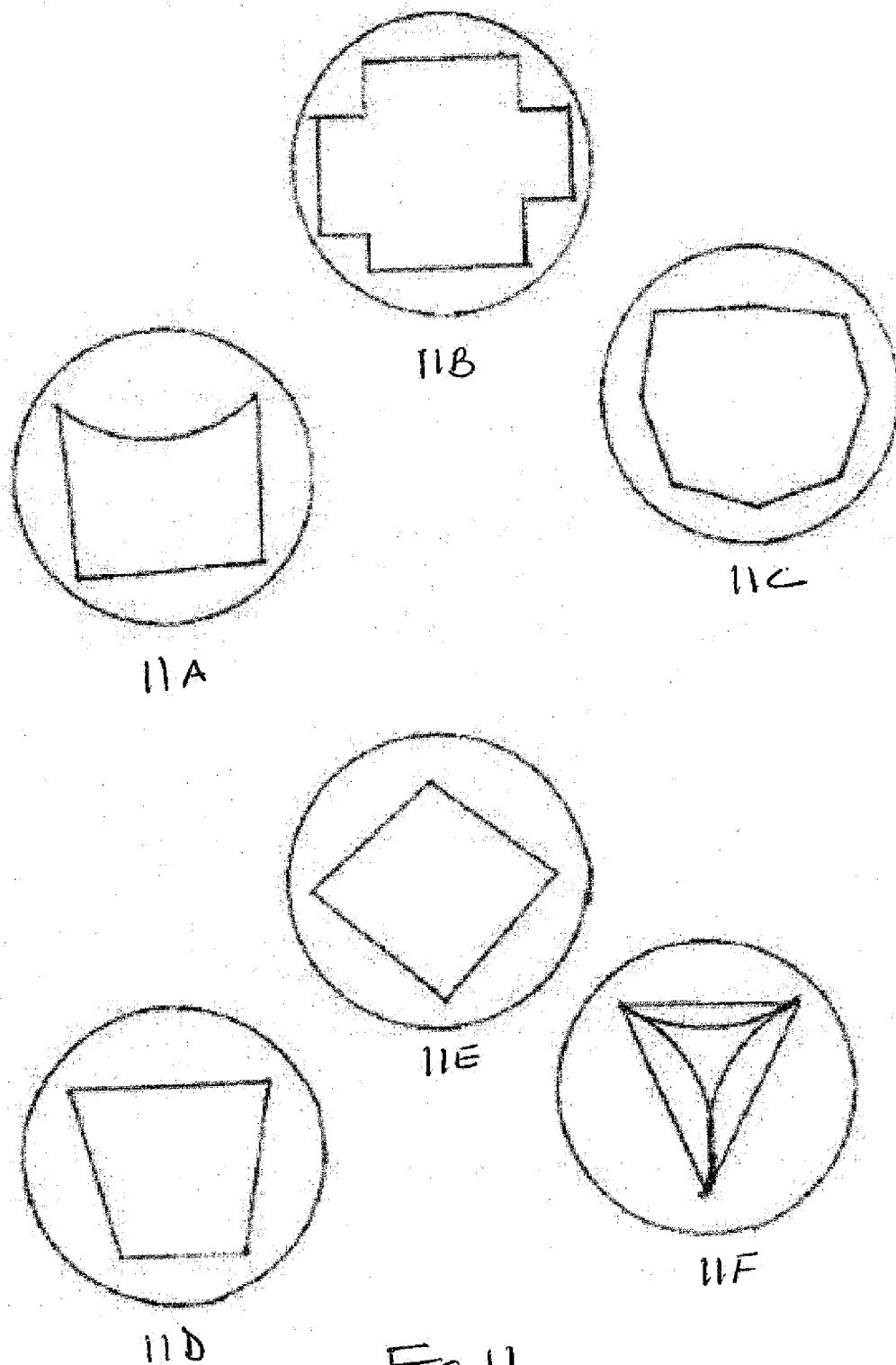

FIG. 9



FIG. 10



FOOD SUPPORT DEVICE

CLAIM OF PRIORITY

[0001] This application claims the benefit of U.S. Provisional Patent Application No. 60/737,935, filed Sep. 16, 2005, the complete contents of which is hereby incorporated herein by reference.

BACKGROUND

[0002] 1. Field of the Invention

[0003] This disclosure relates to a device for supporting food and more particularly an apparatus for supporting and containing drippings from frozen foods.

[0004] 1. Related Art

[0005] Many parents have experience frustration with repeated attempts to decrease the mess and hassle of serving popsicles and other frozen foods to their children. Although children thoroughly enjoy eating popsicles and other frozen foods, parents are always hesitant to serve their children such foods due to the sticky mess that is usually created by the melting and dripping of the frozen food.

[0006] In the past, parents have tried to contain the mess associated with eating frozen foods by surrounding the food with napkins or other absorbent items. However the use of other barriers typically results in additional soiled items rather than the desired result of a mess-free area.

[0007] What is needed is a device that can support a food item that is adapted to contain the mess (i.e. dripping and/or melting food stuff).

SUMMARY

[0008] The described apparatus is a food support device that serves to prevent melting frozen food from running onto the hands (and shirts, pants, shoes, etc.) of the consumer. The described apparatus can be adapted to receive and/or selectively engage various food items and capture any melted food and/or drippings from the food.

BRIEF DESCRIPTION OF THE DRAWINGS

[0009] FIG. 1 depicts an embodiment of a food support device.

[0010] FIGS. 2a and 2b depict alternate embodiments of the food support device depicted in FIG. 1

[0011] FIG. 3 depicts a view of the food support device depicted in FIG. 2 in use.

[0012] FIG. 4 depicts a top view of an alternate embodiment of the food support device shown in FIGS. 1-3.

[0013] FIG. 5 depicts an alternate embodiment of the food support device depicted in FIGS. 1-4.

[0014] FIG. 6 depicts an alternate view of the food support device depicted in FIG. 5.

[0015] FIG. 7 depicts one embodiment of a lid for the device depicted in FIGS. 1-6.

[0016] FIG. 8 depicts an alternate embodiment of a lid depicted in FIG. 7.

[0017] FIG. 9 depicts an alternate embodiment of the lid depicted in FIG. 7.

[0018] FIG. 10 depicts a cross section of the lid depicted in FIG. 9.

[0019] FIGS. 11a-f depict various alternate embodiments of the lid depicted in FIG. 7.

DETAILED DESCRIPTION

[0020] FIG. 1 depicts an embodiment of a food support device 100. In the embodiment shown in FIG. 1, the device 100 includes a base 102 and a lid 104.

[0021] In the embodiment shown in FIG. 1, the base 102 has a top opening 106 that is substantially round. The top opening 106 is sloped towards an opening 108 in the reservoir end 110 of the base 102. In some embodiments, the top opening may not be substantially round, but may have any known and/or convenient geometry. Moreover, while depicted in FIG. 1 as having a generally rounded exterior geometry, in alternate embodiments, the interior surfaces and exterior surfaces can have any known and/or convenient geometric properties.

[0022] In the embodiment shown in FIG. 1 the slope of the interior surface varies from the top opening 106 to the opening 108 in the reservoir end 110. However, in alternate embodiments, the slope can be constant and have any known and/or convenient geometric properties which would allow viscous material to flow from the top opening 106 toward the opening 108 in the reservoir 110 when the device 100 is oriented such that the top opening 106 is up.

[0023] In the embodiment shown in FIG. 1, the lid 104 is adapted to selectively mate with the base 102 by means of a threaded mechanism 112. However, in alternate embodiments, the base 102 and lid 104 can selectively couple in any known and/or convenient manner using any known and/or convenient mechanism.

[0024] In some embodiments the device 100 can include a tether 114 adapted to couple the base 102 and the lid 104. In some embodiments the tether 104 can be coupled with either the base 102 and/or the lid 104 such that the lid 104 can rotate relative to the base 102 without substantially impacting the relative geometric relationship of the ends of the tether 114. In still further alternate embodiments, the tether 104 and/or the lid 104 may be absent.

[0025] In the embodiment shown in FIG. 1, the lid 104 can be configured to mate with the base 102 such that if the lid 104 is coupled with the base 102, liquids and/or solids could be substantially contained within the device 100. In alternate embodiments, the lid 104 can include various apertures such that liquids and/or solids could be partially contained within said device 100 when the lid 104 is coupled with the base 102.

[0026] In the embodiment shown in FIG. 1, both the base 102 and the lid 104 are comprised of a dishwasher-safe and freezer-safe, food-grade plastic. However, in alternate embodiments the base 102 and/or the lid 104 can be comprised of any known and/or convenient material.

[0027] FIGS. 2a and 2b depict alternate embodiments of the base shown in FIG. 1. In the embodiment shown in FIG. 2a, the exterior of the reservoir end 110 includes various grip

regions **202**. In the embodiment shown in FIG. *2a*, the grip regions **202** are comprised of a material selected to facilitate gripping of the device **100**. In some embodiments, the grip regions **202** can be comprised of rubber, latex and/or any other known and/or convenient material. In alternate embodiments, the grip regions can be comprised of the same material as the body of the base **102**, but can be textured to facilitate gripping of the base **102**.

[0028] In the embodiment shown in FIG. *2a*, the gripping regions **202** are depicted as being associated with the underside of the upper portion of the base **102** and the exterior surface of the reservoir end **110**. However, in alternate embodiments, the gripping regions can be located in any known and/or convenient locations on the base **102** and/or lid **104** of the device **100** and/or can be absent.

[0029] In the embodiment shown in FIG. *2b*, the exterior surface of the reservoir end **110** includes a contoured region **204**. The contoured region **204** is configured to facilitate gripping of the base **102** and can have any known and/or convenient geometry to facilitate the gripping of the base **102**. Moreover, in some embodiments, the contoured region **204** can include gripping regions **202**, as described with regard to FIG. *2a*. Although, FIG. *2b* depicts the contoured regions as impacting the interior surface of the reservoir end **110** in alternate embodiments, the contoured region **204** can be included with any impact to the interior surface of the reservoir end **110**.

[0030] FIG. *3* depicts an alternate embodiment of the device **100** shown in FIGS. *1-2b*, in use. In the embodiment shown in FIG. *3*, the base **102** includes stabilizers **302** that are adapted to receive the stick of a food, like a popsicle and/or ice cream, and substantially inhibit movement of the both the food and the stick. In the embodiment shown in FIG. *3*, two stabilizers **302** are depicted. However, in alternate embodiments any number of stabilizers **302** can be used and the stabilizers can be located in any convenient location within the device **100**. In the embodiment shown in FIG. *3*, the stabilizers can be flexible elements that can adapt to receive and restrict movement. However, in alternate embodiments, the stabilizers can be comprised of any known and/or convenient material and can have any known and/or convenient geometric and/or chemical properties,

[0031] In the embodiment shown in FIG. *3*, the device **100** also includes a barrier **304**. The barrier **304** is adapted to allow viscous material to easily flow around the base of the food and into the reservoir end **110**, but is also configured to restrict the flow of viscous material from the below the barrier **304** to the opening above. Thus, the likelihood and/or amount liquid which could flow from below the barrier **304** to the exterior of the device **100**, if the device **100** were inverted, would be reduced. Moreover, the barrier **304** can be adapted to receive and/or stabilize items of various sizes. In some embodiments, the barrier **304** can be comprised of flexible material that can adapt to receive an ice cream cone having a substantially cylindrical shape and/or an ice cream cone having a substantially conical shape.

[0032] FIG. *4* depicts a top view of, an alternate embodiment of the base **102** depicted in FIGS. *1-3*. In the embodiment shown in FIG. *4*, the base **102** includes a perimeter lip **402**. The perimeter lip can be adapted to selective couple with the lid **104** via a press-fit mechanism and/or in any other known and/or convenient manner using any other

known and/or convenient mechanism. Additionally, in some embodiments, the lip **402** can include a return that has been adapted to at least partially contain liquid from being poured from the base **102**.

[0033] In the embodiment shown in FIG. *4*, the base **102** includes a first recessed region **404** adapted to receive a standard cylindrical ice cream cone. The first recessed region **404** can be configured such that it can selectively receive a standard cylindrical ice cream cone and stabilize the ice cream cone against undesired movement. In alternate embodiments, the first recessed region **404** can be adapted to receive any desired food and/or food support and stabilize the same against movement.

[0034] In the embodiment shown in FIG. *4*, the base **102** includes a second recessed region **406** adapted to receive a standard conical ice cream cone. The second recessed region **406** can be configured such that it can selectively receive a standard conical ice cream cone and stabilize the ice cream cone against undesired movement, in alternate embodiments, the second recessed region **406** can be adapted to receive any desired food and/or food support and stabilize the same against movement.

[0035] In the embodiment shown in FIG. *4*, the base **102** includes a third recessed region **408** adapted to receive a standard popsicle stick. The third recessed region **408** can be configured such that it can selectively receive a standard popsicle stick and stabilize it against undesired movement. In alternate embodiments, the third recessed region can be adapted to receive any desired food and/or food support and stabilize the same against movement.

[0036] In the embodiment shown in FIG. *4*, the base can include a plurality of stabilizer elements **410**. In some embodiments, the stabilizer elements **410** can be configured to allow fluid to more easily pass into the reservoir end **110** of the base **102** than to pass from the reservoir end **110** of the base. In the embodiment shown in FIG. *4*, the stabilizer elements **410** can be comprised of a synthetic rubberized material, such as Neoprene™ and/or any other known and/or convenient material. Additionally, in some embodiments, the stabilizer element **410** may not be present.

[0037] FIG. *5* depicts an alternate embodiment of the device **100** depicted in FIGS. *1-4*. In the embodiment shown in FIG. *5*, the device **100** does not include a lid **104**. Additionally, the device is comprised of a disposable material, such as wax-coated paper, paper, card, thin plastic and/or any other known and/or convenient material. In the embodiment shown in FIG. *5*, the device **100** also includes a constricted region **502** that can be adapted to selectively couple with any convenient element. In some embodiments, the constricted region **502** can be absent.

[0038] FIG. *6* depicts an alternate embodiment of the device **100** shown in FIG. *5*. In the embodiment shown in FIG. *6*, reservoir end **110** of the device is small in proportion to the balance of the device **100** than in alternate embodiments depicted herein. Additionally, the curvature **602** of the interface between the reservoir end **110** and the upper portion of the base **102** is higher than in alternate embodiments depicted here. However, in alternate embodiments the relative proportions and geometric relations between the various sections and components of the device **100** can have any known and/or convenient relationship.

[0039] FIG. 7 depicts an alternate embodiment of the lid 104 depicted in FIG. 1. In the embodiment shown in FIG. 7, the lid 104 includes an aperture 702 and a perimeter recess 704. In the embodiment shown in FIG. 7, the aperture 702 is substantially cruciform in shape and occupies a substantial portion of the lid 104. However, in alternate embodiments the aperture can have any known and/or convenient shape and/or can be absent and can occupy any portion and/or no portion of the lid 104.

[0040] In the embodiment shown in FIG. 7, the lid includes a perimeter recess 704. In the embodiment shown in FIG. 7, the perimeter recess is adapted to selectively engage the lip 402 of the base to form a substantially fluid-tight seal.

[0041] FIG. 8 depicts an alternate embodiment of the lid 104 depicted in FIG. 7. In the embodiment shown in FIG. 8, the lid includes an aperture 702 that is substantially star shaped. Additionally, in the embodiment shown in FIG. 8, at least some portions of the edges 802 of the aperture can be comprised of a material different from the balance of the lid 104. In the embodiment shown in FIG. 8, some portions of the edges 802 are comprised of a flexible synthetic rubber, such as Neoprene™. However, in alternate embodiment, at least some portions of the edges 802 can be comprised of any known and/or convenient material.

[0042] FIG. 9 depicts an alternate embodiment of the lid 104 depicted in FIG. 1. In the embodiment shown on FIG. 9, the lid 104 includes a tab 902, an aperture 702 and four elastomeric elements 904. In the embodiment shown in FIG. 9, the lid 104 includes a tab 902 to facilitate removal of the lid 104 from the base 102. In the embodiment shown in FIG. 9, the tab 902 has a substantially triangular shape. However, in alternate embodiments the tab can have any convenient shape and/or the lid 104 can include more than one tab 902.

[0043] In the embodiment shown in FIG. 9, the lid 104 includes four elastomeric elements 904 uniformly spaced around the perimeter of the aperture 702. However, in alternate embodiments, any convenient number of elastomeric elements 904 can be included and the elements 904 can be spaced in any uniform or non-uniform pattern around the perimeter of the aperture 702. In the embodiment shown

in FIG. 9, the elastomeric elements 904 can have a semi-circular shape. However, in alternate embodiments, the elastomeric elements 904 can have any convenient shape.

[0044] In the embodiment shown in FIG. 9, the elastomeric elements can be adapted to at least partially stabilize the them being supported by the base 102 and/or to at least partially restrict flow of a liquid from inside the base 102.

[0045] FIG. 10 depicts a cross-sectional view of a lid 104 with an aperture 702 and a perimeter recess 704.

[0046] FIGS. 11a-11f depicts various geometric configurations of the apertures 702 in a lid 104 including various elastomeric and/or stabilizing elements.

[0047] Any and all dimensions, geometric relations and angles stated here are provided for exemplary purposes only and are not intended in any manner to limit the scope of the disclosed matter. Those skilled in the art will readily understand and recognize that the device can function in a similar fashion with alternate dimensions, geometric relations and angles and readily recognize that alternate dimension, geometric relations and angles are possible without deviation from the spirit of the disclosure.

[0048] Additionally, in the foregoing specification, the embodiments have been described with reference to specific elements thereof. It will, however, be evident that various modifications and changes may be made thereto without departing from the broader spirit and scope of the embodiments. For example, the reader is to understand that the specific ordering and combination of process actions shown in the process flow diagrams described herein is merely illustrative, and that using different or additional process actions, or a different combination or ordering of process actions can be used to enact the embodiments. The specification and drawings are, accordingly, to be regarded in an illustrative rather than restrictive sense.

What is claimed is:

1. An apparatus adapted to receive a food item and contain at least a portion of any spillage of said food item.

* * * * *