



- (51) International Patent Classification:
A61M 1/10 (2006.01)
- (21) International Application Number:
PCT/EP2013/071273
- (22) International Filing Date:
11 October 2013 (11.10.2013)
- (25) Filing Language: English
- (26) Publication Language: English
- (30) Priority Data:
12188316.9 12 October 2012 (12.10.2012) EP
- (71) Applicant: **ABIOMED EUROPE GMBH** [DE/DE];
Neuenhofer Weg 3, 52074 Aachen (DE).
- (72) Inventors: **SIEB, Thorsten**; c/o Abiomed Europe GmbH,
Neuenhofer Weg 3, 52074 Aachen (DE). **SPANIER,
Gerd**; c/o Abiomed Europe GmbH, Neuenhofer Weg 3,
52074 Aachen (DE).
- (74) Agent: **KSNH Patentanwälte, Klunker-
Schmitt-Nilson.Hirsch**; Destouchesstrasse 68, 80796
München (DE).
- (81) Designated States (unless otherwise indicated, for every
kind of national protection available): AE, AG, AL, AM,
AO, AT, AU, AZ, BA, BB, BG, BH, BN, BR, BW, BY,

BZ, CA, CH, CL, CN, CO, CR, CU, CZ, DE, DK, DM,
DO, DZ, EC, EE, EG, ES, FI, GB, GD, GE, GH, GM, GT,
HN, HR, HU, ID, IL, IN, IR, IS, JP, KE, KG, KN, KP, KR,
KZ, LA, LC, LK, LR, LS, LT, LU, LY, MA, MD, ME,
MG, MK, MN, MW, MX, MY, MZ, NA, NG, NI, NO, NZ,
OM, PA, PE, PG, PH, PL, PT, QA, RO, RS, RU, RW, SA,
SC, SD, SE, SG, SK, SL, SM, ST, SV, SY, TH, TJ, TM,
TN, TR, TT, TZ, UA, UG, US, UZ, VC, VN, ZA, ZM,
ZW.

- (84) Designated States (unless otherwise indicated, for every
kind of regional protection available): ARIPO (BW, GH,
GM, KE, LR, LS, MW, MZ, NA, RW, SD, SL, SZ, TZ,
UG, ZM, ZW), Eurasian (AM, AZ, BY, KG, KZ, RU, TJ,
TM), European (AL, AT, BE, BG, CH, CY, CZ, DE, DK,
EE, ES, FI, FR, GB, GR, HR, HU, IE, IS, IT, LT, LU, LV,
MC, MK, MT, NL, NO, PL, PT, RO, RS, SE, SI, SK, SM,
TR), OAPI (BF, BJ, CF, CG, CI, CM, GA, GN, GQ, GW,
KM, ML, MR, NE, SN, TD, TG).

Declarations under Rule 4.17:

- as to applicant's entitlement to apply for and be granted a
patent (Rule 4.17(ii))

Published:

- with international search report (Art. 21(3))

(54) Title: CENTRIFUGAL BLOOD PUMP

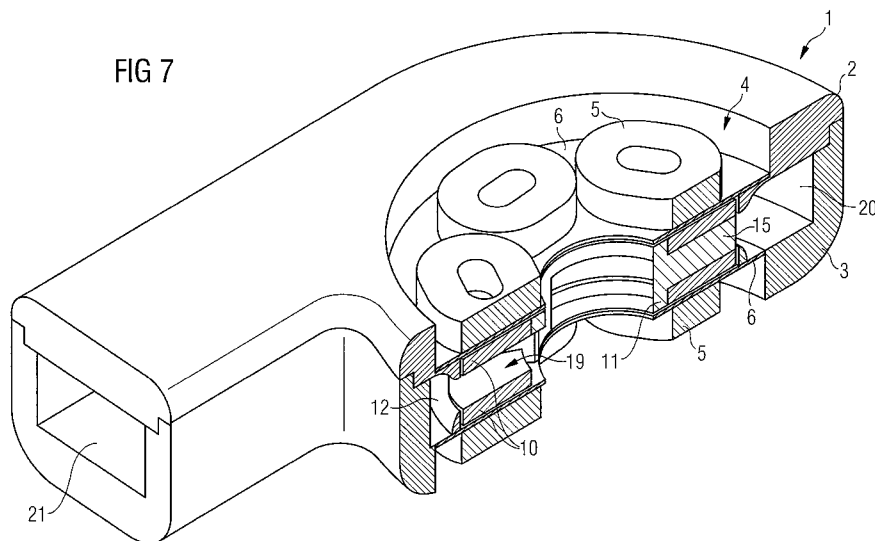

(57) Abstract: A centrifugal blood pump without a mechanical bearing comprises a pump casing (1), an impeller (9) arranged in the pump casing rotatably about the central axis and freely movable axially and radially within a limited clearance. The impeller has permanent magnets or permanently magnetized magnetic regions (N/S) which cooperate with an electromagnetic drive to set the impeller rotating. A circular wall (12) or circularly arranged wall sections are provided within the pump casing, their inner surfaces defining a radial clearance together with the outer circumference of the impeller to form a hydrodynamic radial bearing for the impeller.



Centrifugal blood pump

BACKGROUND OF THE INVENTION

5

The invention relates to a centrifugal blood pump, i.e. a pump having a rotating impeller by means of which blood is transported in an outward radial direction.

10 The blood pump is particularly suitable for long-term blood conveyance but may likewise be used only temporarily and offers a delivery rate of at least 4 and up to 10 liters per minute.

Centrifugal blood pumps for long-term use are described e.g. in US 6,623,475
15 B1. In order to render the blood pump suitable for long-term use, mechanical bearings are omitted in this type of blood pump so as to avoid the danger of abrasive particles of the bearings contaminating the blood and further to prevent thrombosis from occurring at the bearings. In addition, bearing wear is commonly the most life-shortening parameter of a blood pump. Instead,
20 the impeller of the pump is freely movable within a limited clearance in the pump casing. The impeller is rotated by means of an external electromagnetic drive cooperating with magnets provided on the blades of the impeller. Radial centering of the impeller results from the impeller magnets axially cooperating with the driving means. However, the magnetic forces of the im-
25 peller magnets tend to pull the impeller axially towards the electromagnetic drive and, thus, against the wall separating the drive from the impeller. In order to overcome such axial attraction forces, the impeller blades comprise supporting surfaces which hydrodynamically lift the impeller during rota-

tion such that the impeller slides on a fluid cushion, i.e. a blood cushion, thus being kept at an axial distance from said wall. In this way, the impeller is centered in the pump casing both radially and axially without any bearing and without any impeller mounting shaft.

5

Blood pumps of the afore-described present type may be attached to the apex of the left ventricle. An outflow graft of the blood pump is attached to the ascending or descending aorta. Once in place, blood flows from the left ventricle through the blood pump into the aorta and circulates into the body.

10 The pump is electrically driven and the drive line cable accesses the patient's skin and connects the implanted pump to an externally worn controller, which may be powered by batteries. The required power consumption lies below 10 W, preferably in the range of 6 W under physiologically relevant operating conditions, such that the pump has a long service life even when
15 configured as a battery-operated portable device or when used with a wireless TET (transcutaneous energy transport) or TEIT (transcutaneous energy and information transport) device.

The poles of horse-shoe-like electromagnets of the electromagnetic drive are
20 arranged outside the pump casing above and below the respective poles of the magnets of the impeller. Cyclically changing the poles of the electromagnets causes them to generate a rotating magnetic field carrying along the impeller. A maximum efficiency can be achieved with this type of electromagnetic drive when the change of the poles of the electromagnets is coordinated
25 close to the breakdown torque, i.e. with a relatively large distance between the carrying electromagnets and the respectively carried magnets of the impeller. However, this has the adverse effect that the axial attracting forces between the electromagnets and the impeller magnets become relatively small so that the radial self-centering effect on the impeller is also small. Thus, in

- 3 -

order to maintain a radial self-centering effect, the blood pump is not operated with its maximum efficiency.

In order to increase the torque on the prior art impeller, the strength of the
5 impeller magnets, i.e. the amount of magnetic material on the impeller, could
be increased, but this is limited due to the size and maximum weight of the
blood pump, which, for the present invention, should not exceed a diameter
of 40 mm and a height of 12 mm and which should weigh less than 50 grams,
preferably less than 40 grams. In addition, the stronger the magnets are, the
10 more difficult it is to get the pump started, because in the starting phase the
magnets of the impeller cling to the horseshoe-like electromagnets of the
electromagnetic drive means.

Alternatively, the energy supplied to the electromagnets could be increased.
15 But this is difficult to achieve, because the energy consumption of the pump
should be kept low at less than 10 W, preferably no more than 6 W, such that
the pump has a long service life when configured as a battery-operated port-
able device or such that it can be driven by a TET or TEIT device.

20 There is thus the general problem of increasing the torque on the impeller of
the blood pump while at the same time ensuring that the impeller remains
axially and radially centered without any mechanical bearing.

A centrifugal blood pump of the general type as described above is known
25 from HeartWare International Inc., Framingham, Massachusetts. The impel-
ler is radially centered with passive magnetic forces using static magnets cen-
trally arranged in the pump housing, on the one hand, and repelling magnets
mounted on an inner circumference of the impeller, on the other hand. How-
ever, the provision of additional magnets for the radial centering of the im-

- 4 -

5 peller substantially adds to the overall weight of the pump. In addition, the repelling magnets of the impeller tend to be drawn axially towards the electromagnets of the drive means. Therefore, only a few starts are guaranteed with this pump. In addition, the axial magnetic forces are twice as high as the radial balancing forces. This massive axial force has to be levitated by the axial hydrodynamic lifting forces, which limits the pump's maximum rotational speed.

BRIEF SUMMARY OF THE INVENTION

10

It is therefore a primary object of the present invention to provide a centrifugal blood pump which has a low weight and can offer high torque on the impeller, wherein the impeller is axially and radially centered without any mechanical bearing. A secondary object of the present invention is to provide a centrifugal blood pump with reduced frictional forces at the time when the pump is started.

15

The primary object is achieved according to the present invention by a centrifugal blood pump with the features of independent claim 1. Preferred embodiments and further developments of the invention are specified in the claims dependent thereon.

20

The centrifugal blood pump of the present invention without a mechanical bearing has a pump casing with a central axis, a blood flow inlet disposed along said central axis and a blood flow outlet disposed on a circumference of the pump casing, as is generally known e.g. from US 6,623,475 B1. Furthermore, the centrifugal blood pump has an impeller that is rotatably arranged about said central axis in the pump casing and has radially extending blades defining passages therebetween for radial blood flow. The impeller is

25

- 5 -

freely movable both axially and radially within a limited axial clearance and a limited radial clearance. The impeller is provided with permanent magnets or permanently magnetized magnetic regions which cooperate with an electromagnetic drive such that the impeller can be set rotating about said central axis, as is also generally known from US 6,623,475 B1. According to the invention, the radial clearance within which the impeller is freely movable is defined by an outer circumference of the impeller and an inner surface of a circular wall or plurality of wall sections arranged in a circle about the central axis within the pump casing. The radial clearance is 100 μm or less, so as to provide a hydrodynamic radial bearing for the impeller in the pump casing. Preferably, the radial clearance is 50 μm or less. With a clearance of about 50 μm , a constant lifting force can be guaranteed while allowing for sufficient blood to pass through the narrow gap to wash all pump and impeller surfaces. The hydrodynamic radial bearing makes it possible to dispense with any mechanical radial bearing and further makes it possible to dispense with or at least reduce the size of a static magnetic radial bearing.

The radial clearance between the impeller and the wall or wall sections preferably comprises a plurality of sections in which the clearance converges radially, when seen in the direction of rotation of the impeller. In other words, in these sections the gap defined by the radial clearance between the impeller and the wall or wall sections becomes smaller in a circumferential direction. As a result, upon rotation of the impeller, blood is transported into the clearance and, due to the clearance converging in the direction of rotation of the impeller, tends to urge the impeller away from the wall or wall sections, thereby contributing to the radial centering of the impeller about the central axis of the pump casing while minimizing the time during which the blood components are exposed to significant shear forces.

The converging sections can be realized by providing corresponding recesses in the radially inner surface of the wall or wall sections or by providing the outer circumferential surface of the impeller with respective recesses or ramps, or by a combination of recesses or ramps on the outer circumferential surface of the impeller and radially inner surface of the wall or wall sections.

In order to prevent the impeller from axially clinging to an adjacent wall due to attracting forces acting between the permanent magnets of the impeller and the electromagnets, it is preferably provided to construct the electromagnetic drive with coils having no ferromagnetic core. In this situation, for the coils to generate the necessary magnetic fields that are usually provided by the ferromagnetic cores penetrating the prior art coils, the coils (without a core) are arranged in a plane axially spaced from the impeller, namely immediately above or below or, preferably, above and below the impeller magnets, at a minimum distance. For instance, the wall separating the coils from the impeller may consist of a 100 μm thick, or even thinner, ceramic plate. Without the ferromagnetic core, the magnets of the impeller are not magnetically attracted to the electromagnetic drive when the electromagnetic drive is not in operation. This substantially reduces the friction between the impeller and the axially adjacent walls, not only at the time when the impeller is set rotating but also during its operation, since the two sets of electromagnetic drive coils are perfectly mirror imaged on both sides of the impeller and, as such, balance the axial forces. Accordingly, the magnets on the impeller may be made stronger as compared to the prior art impeller magnets, thereby further increasing the maximum possible torque that can be imposed on the impeller by the electromagnetic drive.

The thickness of the ceramic plate is chosen such that it does not severely affect the magnetic field created by the coils, but is sufficiently strong to with-

- 7 -

stand sliding contact with the impeller. Accordingly, a preferred thickness of the ceramic plate is within the range of 50 to 150 μm , preferably 80 to 120 μm , more preferably about 100 μm .

- 5 The coils are preferably potted in a polymer matrix to stabilize them and protect them from corrosion. It is preferred to mount the coils preferably directly, or alternatively indirectly, on the aforementioned ceramic disc, which limits the axial movement of the impeller, so that the coil and the ceramic disc form an integral component. The polymeric material in which the coils are
- 10 potted can be cast directly on the ceramic disc.

The coils preferably have a non-circular axial cross section, more preferably a substantially oval or trapezoidal one, so as to better fill the available space or, in other words, so as to increase the overall axial cross section of the set of

15 coils. Due to the increased coil cross sections, stronger magnetic fields can be created and, thus, the torque on the impeller can be increased.

In some embodiments of the invention, the radially outer surface of the impeller blades, together with the circular wall or circularly arranged wall sections, may define the hydrodynamic radial clearance. In these cases it is advantageous when the radially outer surfaces of the impeller blades cover a

20 large part of the impeller's outer circumference. Thus, the circumferential dimension of at least one or all of the impeller blades preferably increases radially, so that an axial cross section of the impeller may roughly have a triangular or trapezoidal form. As stated above, the radially outer surfaces of the

25 impeller blades may have recesses which, together with the inner surface of the circular wall or circularly arranged wall sections, form converging sections into which blood is transported upon rotation of the impeller so as to urge the impeller away from the wall or wall sections.

- 8 -

It is further advantageous if an impeller blade has a leading surface, as seen in the direction of rotation of the impeller, which is convex with respect to the blade's radial extension. This design supports the radial centering of the impeller and offers a more laminar blood flow as compared to an impeller
5 with straight or concave blades. It further provides a higher primary pressure increase within the impeller.

It has been found to be particularly advantageous if the aspect ratio (i.e. the ratio of the diameter versus the height) of the impeller is 4 : 1 or more, preferably 6 : 1 or more. The higher the aspect ratio is, the more stable the impeller is with respect to wobbling about the axis of rotation.
10

It is further generally advantageous if the radial blood flow passages defined between the impeller blades are relatively wide. Therefore, instead of providing each impeller with one magnet or one magnetic region, it is preferable to
15 combine two magnets or magnetic regions in one impeller blade. In this way, the number of impeller blades can be halved, thereby doubling the width of the impeller blades as well as the width of the blood flow passages therebetween. Accordingly, in a preferred embodiment, a first magnet or magnetic
20 region and a second magnet or magnetic region, each having a north pole and a south pole, are combined in one impeller blade, with the north and south poles of the first magnet or magnetic region being arranged upside down with respect to the north and south poles of the second magnet or magnetic region.

25

Since the blood pump according to the invention is designed for long-term use, the magnetic material of the impeller must be protected from corrosion caused by the contact with blood. Therefore, the magnets or magnetic regions of the impeller are preferably covered all over with metal, such as tita-

nium or a biocompatible precious metal. The thickness thereof is preferably no more than 50 μm , more preferably no more than 20 μm , in order not to inordinately reduce the effectiveness of the magnet.

- 5 If a circular wall is provided within the pump casing to define the hydrodynamic radial clearance together with the outer circumference of the impeller, such wall preferably has a plurality of circumferentially spaced through openings for blood to flow from the impeller towards the pump casing's blood flow outlet. In one embodiment, however, the circular wall can be
- 10 subdivided into two circular rings on each side of the rotor, which eliminates the need for such openings and leads to a 360° ring-like opening. The 360° through flow opening can in addition – depending on the wall thickness of the two circular wall rings – serve as a first diffuser providing a first pressure increase. Likewise, the circumferentially spaced through openings can serve
- 15 as a first diffuser. Such through openings are not needed where the circular wall is replaced with wall sections arranged in a circle about the central axis of the pump casing, because in this case the through openings are formed by the gaps between neighbouring wall sections.
- 20 In case the wall thickness is used to provide a first diffuser, the wall thickness is preferably at least 2 mm. Preferably, the cross-section of the ring-like opening or the spaced apart opening increases in a radially outward direction, wherein the opening angle of the opening or openings preferably does not exceed 7°. Greater opening angles would cause a detachment of the flow and
- 25 lead to undesired turbulences. The openings may be equal along the circumference of the circular wall and/or the wall thickness may be constant. In an embodiment the height, width and/or diameter of the openings may be different and/or the wall thickness (i.e. the length of the openings) may vary along the circumference of the circular wall. This means that the deceleration

of the blood in the first diffuser may either be constant or may vary along the circumference of the circular wall. This way, by means of the first diffuser a constant pressure along the circumference of the impeller can be achieved such that the radial hydrodynamic bearing is stable and does not oscillate or
5 vibrate due to pressure variations at the pump inlet. Although a diffuser effect could also be achieved by increasing the diameter of the impeller, such that the passages serve as a diffuser, it is preferred to provide the diffuser in the circular wall or wall sections because a greater diameter of the impeller leads to greater shear forces at the outer circumference of the impeller.

10

In order to avoid pulsation of the blood flow, caused by the blood flowing from the impeller through the circular wall or circularly arranged wall sections towards the pump casing's blood flow outlet, all distances between adjacent through openings in the wall or wall sections are made smaller than all
15 distances between the radially outer ends of the impeller blades. Accordingly, a passage defined between two adjacent impeller blades is always open to at least one through opening provided in the circular wall or circularly arranged wall sections.

20 A ring diffuser is preferably provided peripherally of the circularly arranged wall or wall sections, and the blood flow outlet of the pump casing is preferably tangentially disposed on the pump casing's circumference, i.e. the ring diffuser preferably ends in a tangential outlet. The cross section of the ring diffuser preferably increases linearly or exponentially along its circumferen-
25 tial direction. Alternatively, the ring diffuser may have a constant cross section.

The invention will be described in further detail in relation to two preferred embodiments and some variants thereof. According to the first embodiment,

- 11 -

the impeller comprises a first disc and a second disc which are axially spaced apart. Each disc has magnetic regions and a central opening arranged for axial blood flow centrally through the discs, such as axial blood inflow through the first disc and axial blood outflow through the second disc, or axial blood inflow through both the first and second discs. In this first embodiment, the blades of the impeller are arranged between the two magnetic discs so that blood flows mainly radially between the two discs through the passages defined by the blades.

10 However, a small part of the blood flows above and below the plates so that the impeller is hydrodynamically supported on both axial sides thereof and thorough washing of all surfaces is guaranteed. The blood flow above and below the two discs is relatively low, but sufficient to keep the impeller axially spaced apart from the pump housing. The respective surfaces of the discs are preferably planar and the respectively adjacent walls, such as the aforementioned ceramic plates, are preferably likewise planar so that the blood flows between the planar disc surfaces and the adjacent planar walls. Thus, the overall construction is relatively simple.

20 However, the hydrodynamic lifting effect may be increased if one or both of the disc surfaces and/or one or both of the adjacent walls provides ramps extending about the central axis in a circumferential direction.

The radially outer circumference of the first and second magnetic discs of the impeller is preferably circular and forms at least a part or all of the radially outermost circumference of the impeller which, together with the inner surface of the wall or plurality of wall sections, defines the radial clearance forming the hydrodynamic radial bearing for the impeller. As mentioned above, in the case that the outer circumference of the first and second discs

are the sole impeller portions contributing to the hydrodynamic radial bearing for the impeller, the plurality of wall sections may comprise an upper circular wall section and a lower circular wall section which are axially spaced apart so as to form one continuous circumferential through opening for
5 blood flow from the impeller towards the blood flow outlet of the pump casing. Thus, any wall sections blocking or hindering the blood which leaves the impeller radially can be omitted. As a result, the blood flow is more laminar and blood damage is reduced.

10 However, where the wall or plurality of wall sections provide a plurality of circumferentially spaced through openings for blood to flow from the impeller towards the blood flow outlet, as explained above, all distances between two adjacent through openings are preferably smaller than all distances between the radially outer ends of the impeller blades, in order to avoid pulsa-
15 tion of the blood flow. In this way, all of the radial blood flow passages defined between the impeller blades are always in flow communication with the outflow opening of the pump casing.

According to a variant of the first embodiment, the first and second discs do
20 not form an outer circumference of the impeller, but rather one or both of the first and second discs are circumferentially surrounded by a circular rim which axially extends from the axial side or sides of the impeller blades and integrally interconnects the blades. In this variant, the circular rim forms a part or all of the radially outermost circumference of the impeller and as-
25 sumes the same hydrodynamic bearing function that has been explained above in respect of the variant where the outer circumference of the first and/or second magnetic discs contributes to the hydrodynamic radial bearing of the impeller.

It is preferable in this variant of the first embodiment as well as in other variants of this and all other embodiments of the invention to form all blades of the impeller together as an integral injection moulded piece, except in the case where the blades are formed entirely from magnetic material.

5

The second embodiment differs from the first embodiment in that the impeller comprises only one disc rather than two discs. The single disc has a central opening arranged for axial blood flow through the disc, and the impeller blades are arranged on the disc so as to extend axially from both axial sides of the disc. In this second embodiment, the impeller blades are either formed as magnets, i.e. they are entirely formed from magnetic material, or have magnetic regions. This is important because the disc is centrally arranged within the impeller and, therefore, relatively far away from the coils of the magnetic drive. The disc can therefore contribute only little to the maximum torque achievable with the blood pump, even if it is made from magnetic material. Nevertheless, according to one variant of the second embodiment, both the disc and the blades may be made of ferromagnetic metal. The ferromagnetic metal is permanently magnetized so that alternating magnetic regions are provided, preferably without interruption, along the entire circumference of the impeller. It is even possible and further preferable in this variant to form the disc and the blades as an integral piece of ferromagnetic metal, said piece, including the disc, being magnetized.

Since a disc made of metal substantially adds to the overall weight of the blood pump, another preferred variant of the second embodiment provides for the disc comprising or being entirely made of polymer material. The overall weight of the blood pump can thus be reduced.

25

According to another variant of the second embodiment, the disc and the impeller blades may be composed as two semi-shells, within which the magnets are housed. The shells may be injection moulded.

- 5 In this second embodiment, the circular wall or circularly arranged wall sections may also provide a plurality of circumferentially spaced apart through openings for blood to flow from the impeller towards the blood flow outlet, whereby, as explained, all distances between two adjacent through openings are preferably smaller than all distances between radially outer ends of the
10 impeller blades, in order to prevent pulsation of the blood flow.

However, in a variant, the wall may extend radially inward so as to form, together with the circular radially outer surface of the impeller disc, the hydrodynamic radial bearing for the impeller. Accordingly, the blood may
15 leave the impeller towards the pump casing's blood flow outlet partially above the radially extending wall and partially below the radially extending wall without any wall sections blocking or hindering such blood flow.

In the second embodiment, similarly to the prior art blood pump disclosed in
20 US 6,623,475 B1, a hydrodynamic bearing is provided for axially mounting the impeller so as to lift the impeller from the adjacent wall or walls, such as the afore-mentioned ceramic plate, upon rotation of the impeller. Accordingly, the impeller blades have upper and lower surfaces, whereby one or both of the upper and lower surfaces, together with the respective adjacent wall,
25 define an axial clearance having sections in which the clearance converges in a circumferential direction. More specifically, the upper and lower surfaces provide ramps extending about the central axis in a circumferential direction so as to create a hydrodynamic axial force on the impeller. The ramp of one or more of the upper and lower surfaces may be formed as a curved or ta-

- 15 -

pered leading edge of the respective blade, as seen in the direction of rotation of the impeller, passing into a straight section, which may be horizontal, i.e. perpendicular to the central axis, or inclined.

5

BRIEF DESCRIPTION OF THE DRAWINGS

Preferred embodiments of the invention will hereinafter be described in more detail with reference to the accompanying drawings, in which:

- 10 Figure 1 shows a perspective view of a blood pump according to a first embodiment of the invention,
- Figure 2 shows the blood pump as shown in Figure 1 without the upper set of electromagnetic coils and the planar ceramic surface,
- 15 Figure 3 shows the blood pump as shown in Figure 2 without the impeller,
- Figure 4 shows the blood pump as shown in Figure 2 without the upper pump housing shell and without the upper magnetic disc of the
- 20 impeller,
- Figure 5 shows an alternative upper pump housing shell upside down, having a wall without hydrodynamic pockets,
- 25 Figure 6 shows the lower pump housing shell of the blood pump with the lower set of electromagnetic coils arranged on a thin ceramic disc,
- Figure 7 shows a cross sectional view of the blood pump of Figure 1,

- 16 -

Figure 8 shows the blade rotor of the impeller of the blood pump of Figure 1,

Figure 9 shows a first alternative blade rotor,

5

Figure 10 shows a second alternative blade rotor,

Figure 11 shows a third alternative blade rotor,

10 Figure 12 shows an alternative impeller for the blood pump of Figure 1 entirely made of ferromagnetic material,

Figure 13 schematically shows top views of various blade rotor forms,

15 Figure 14 shows a first variant of an impeller of a second embodiment of the blood pump,

Figure 15 shows a second variant of the impeller of the second embodiment,

20 Figure 16 shows a third variant of the impeller of the second embodiment,

Figure 17 shows a fourth variant of the impeller of the second embodiment,

25 Figure 18 shows an alternative upper pump housing shell upside down, similar to that of Figure 5, having a wall with a sufficient thickness such that the openings may serve as a diffuser, and

Figure 19 shows a cross sectional view of the wall of the upper pump housing shown in Figure 18.

DETAILED DESCRIPTION OF PREFERRED EMBODIMENTS

- 5 Figure 1 shows a first embodiment of a centrifugal blood pump with a casing 1 comprising an upper shell 2 and a lower shell 3. The upper shell 2 as well as the lower shell 3 each have a circular recess 4 accommodating a set of six electromagnetic coils 5 therein. The number of coils can be different and is preferably dividable by three. The coils 5 do not have any ferromagnetic
- 10 core. Preferably, they have an oval shape and may alternatively have a trapezoidal shape, so as to fully exploit the available space within the recess 4. The coils 5 are encapsulated in a polymer matrix directly on a very thin circular ceramic plate 6 having a thickness of only about 100 μm . The ceramic plate 6 has a central hole 7 constituting a blood flow inlet through which
- 15 blood can enter the blood pump when the blood pump is appropriately connected e.g. to the apex of the left ventricle. The blood will exit the blood pump through the blood flow outlet 21. The ceramic plate 6 with the electromagnetic coils 5 mounted thereon together form a unitary coil assembly.
- 20 Figure 2 shows the blood pump of Figure 1 without the coil assembly 5, 6. As can be seen, the recess 4 in the upper shell 2 of the pump casing 1 has a ledge 8 on which the ceramic plate 6 rests. The ledge 8 defines a step or further recess within the recess 4, within which the impeller 9 is accommodated so that it can rotate about a central axis of the pump casing 1. The impeller 9 comprises an upper magnetic disc 10 and a lower magnetic disc (not shown) and
- 25 further a blade rotor 11 sandwiched between the two magnetic discs 10. The upper and lower surfaces of the impeller 9 and the axially inner surfaces of the upper and lower ceramic plates 6 of the two coil assemblies define a limited axial clearance within which the impeller 9 is freely axially movable. The

- 18 -

radially outer circumference of the impeller 9 together with the lower inner surface of the stepped recess 4 define a radial clearance within which the impeller 9 is freely radially movable.

- 5 The lower wall 12 of the recess 4 limiting the radial clearance for the impeller 9 can be seen better in Figure 3. The wall 12 is free-standing and has through openings 13 through which blood being radially propelled by the impeller can pass into a ring diffuser 20 (Figure 4) arranged peripherally of the wall 12. Instead of the wall 12 having through openings 13, the wall may alternatively be composed of axially extending, spaced apart wall sections providing through openings therebetween.
- 10

The wall 12 is further provided with pockets 14 which are configured to enhance a hydrodynamic radial bearing effect on the impeller 9, when the impeller rotates about the pump casing's central axis. In the wall sections of the pockets 14, the radial clearance defined between the impeller's 9 outer circumference and the inner surface of the wall 12 radially converges, as seen in the direction of rotation of the impeller, which is indicated in Figure 3 by an arrow.

15

20 Figure 4 shows the lower shell 3 with the blade rotor 11, the upper and lower magnetic discs 10 of the impeller 9 being removed. As can be seen, the blade rotor 11 has three radially extending blades 15 held together by a central circular ring 16 and two upper and lower circumferential rings 17, 18. Passages 19 are defined between the blades 15 for blood to flow radially from a blood flow inlet, corresponding to the central hole 7, to the ring diffuser 20 arranged peripherally of the blade rotor 11 and further to a blood flow outlet 21 of the pump casing. Upon rotation of the impeller 9, the upper and lower circumferential rings 17, 18 will slide along the wall 12, namely above and

25

- 19 -

below the wall's 12 through openings 13, whereas the radially outer surfaces 22 of the blade 15 and the passages 19 defined therebetween will pass along the through openings 13 of the wall 12 (see Figure 3). The distances between two adjacent through openings 13 in the wall 12 (or between corresponding
5 axially extending wall sections) are dimensioned so that they are smaller than all distances between the radially outer ends of the blades 15 of the blade rotor 11. In this way, pulsation of the blood flow through the impeller 9 can be avoided, as the blood flow passages of the impeller are always open in a radially outward direction.

10

Figure 5 shows an alternative upper shell 2' which differs from the upper shell 2 in Figure 3 in that it has a larger number of through openings 13 and, more importantly, the inner surface of the wall 12 lacks pockets 14. A hydrodynamic radial bearing will nevertheless be established once the impeller 9 is set rotating. Alternatively (not shown), the wall 12 may be divided into an
15 upper circular wall section forming part of the upper shell 2 and a lower circular wall section of the lower shell 3, each wall section preferably being provided with the afore-mentioned pockets 14, a continuous circular through opening 13 being formed between the two circular wall sections.

20

Figure 6 shows the lower shell 3 of the pump casing 1 with only the lower coil assembly 5, 6 positioned in a recess (not shown) of the lower shell 3. The central opening 7 in the coil assembly 5, 6 can be provided on one or both coil assemblies, thus allowing axial blood inflow from only one side or on
25 both sides of the impeller.

Figure 7 shows a cross-sectional view of the blood pump described above with all elements accordingly numbered. As can be seen, the upper and lower coil assemblies 5, 6 are identical in size and structure. The lower ceramic

- 20 -

plate 6 can be supported on the free end of the wall 12 of the upper shell 2. The blade rotor 11 of the impeller 9 carrying a magnetic disc 10 on each side, as shown in the cross-sectional view in Figure 7, is cut at one side through a blade 15 and at the other side through a passage 19 defined between two
5 blades 15. As further becomes apparent from the cross-sectional view in Figure 7, the cross section of the ring diffuser 20 increases in the circumferential direction of the blood pump in this embodiment.

Upon rotation of the impeller 9, blood flows radially through the passages 19
10 and also above and below the impeller's 9 magnetic discs 10 between the discs 10 and the ceramic plates 6. Their mutual contact surfaces are planar. Alternatively, one or both of these surfaces may have ramps extending in a circumferential direction so as to create a hydrodynamic lifting effect on the impeller. Although the lower ceramic plate 6 is shown as having a central
15 hole, similar to the central hole 7 of the upper ceramic plate 6, the lower ceramic plate 6 preferably has no central hole but completely seals against blood leakage.

Figure 8 shows the blade rotor 11 separately, including the blades 15 and
20 their radially outer surfaces 22, the through openings 13 defined between the blades 15, the central circular ring 16 as well as the upper and lower circumferential outer rings 17 and 18 connecting the blades 15 to form an integral piece, which is preferably injection moulded. The blades 15 of the impeller 9 have an axially extending leading edge 23, as seen in the direction of rotation
25 of the impeller, which is curved or tapered in order to enhance the hydrodynamic effect of the radially outer surfaces 22 and reduce blood damage. The number of blades 15 can be more than three, e.g. four, five or six. Likewise, the angular extension α of the blades may be larger or smaller than shown in

Figure 8. Also, the inner diameter of the blades may be larger or smaller than shown in Figure 8.

Figures 9, 10 and 11 show a first, a second and a third variant of the blade rotor 11. The blade rotor 11 in Figure 9 differs from the blade rotor 11 in Figure 8 in that the upper and lower circumferential rings 17, 18 are interrupted. The hydrodynamic radial bearing for the impeller 9 is achieved with this variant of the blade rotor 11 mainly by the radially outer surfaces 22 of the blades 15. Alternatively, the magnetic disc 10 (not shown in Figure 9) may be formed such that it fills the space of the missing sections of the upper and lower circumferential rings 17, 18. Here, too, it is advantageous if the blades 15 of the impeller have an axially extending leading edge, as seen in the direction of rotation of the impeller, which is curved or tapered in order to increase the hydrodynamic effect for the hydrodynamic radial bearing of the impeller and in order to reduce blood damage.

Figure 10 shows a second variant of the blade rotor 11 in which the blades 15 are formed as straight bars, so that the passages 19 defined between adjacent blades 15 are accordingly increased.

The blade rotor 11 in Figure 11 is formed from a polymeric washer-like disc having a number of radially extending passages 19 which may overlap in a central area of the blade rotor 11. The radial passages 19 may have a constant cross section or, as shown at 19.1, may have a cross section which increases towards the outer circumference.

In the embodiments described so far and in all variants thereof, the magnetic discs 10 are magnetized in sections in opposite directions. Each section has a first pole at the upper side of the disc and the respective opposite pole on the

lower side of the disc. The number of magnetized sections is preferably eight but may likewise be four or twelve and should be different from the number of coils 5. Furthermore, instead of the upper and lower circumferential rings 17, 18, the radial dimensions of the circular magnetic discs 10 may be such
5 that the outer circumferential radial surfaces of the magnetic discs replace the upper and lower circumferential rings 17, 18. In this case, the blades 15 are interconnected only by the central circular ring 16. The advantage is that more magnetic material is present, so that the maximum torque provided by the impeller may accordingly be increased.

10

Figure 12 shows a further variant of an impeller that can be used in connection with the blood pump according to the first embodiment. Here the impeller is entirely made from permanently magnetized ferromagnetic material, i.e. not only the upper and lower magnetic discs 10 but also the radially extending blades 15 are magnetic. Again, the blades 15 have an axially extending leading edge 23, as seen in the direction of rotation of the impeller, which is curved or tapered in order to reduce blood damage. To reduce the likelihood of corrosion and increase the hemo-compatibility, the rotor may be encapsulated or shielded by a polymeric or metal housing. The encapsulation
15 can be provided in a polymeric moulding process or by galvanic metal deposition.
20

The blade rotor 11 may have more than three blades 15, and the form of the blades 15 need not be triangular or trapezoidal or straight. Figure 13 schematically shows top views of various blade rotor forms. Among these forms,
25 blade rotors with curved blades are preferred. It is particularly preferred when the leading surface 22b of the impeller blades 15, as seen in the direction of rotation of the impeller, is convex with respect to its radial extension.

- 23 -

Figure 14 shows a first variant of an impeller 9 of a second embodiment of a blood pump. The pump casing 1, upper shell 2, lower shell 3, recesses 4, coil assemblies comprising the coils 5 and ceramic plates 6, wall 12 or wall sections within the pump casing 1, through openings 13 extending through the wall 12 or between corresponding wall sections, ring diffuser 20 and blood flow outlet 21 in the second embodiment are identical to those of the first embodiment described above. The only difference in the second embodiment is the impeller 9, which comprises only one disc 10 with a central opening 7, rather than two magnetic discs 10. The disc 10 in the second embodiment is centrally arranged, as seen in an axial direction, and may or may not be magnetic. The blades 15 of the impeller 9 extend axially from both axial sides of the disc 10 and are formed as magnets or may have magnetic regions. Blood flow passages 19 are defined between adjacent blades 15.

In addition, in a variant of the second embodiment, the wall 12 or wall sections arranged within the pump casing may be formed as a radially inward extending wall arranged horizontally, so as to form together with the circular radially outer surface of the central disc 10 the afore-described hydrodynamic radial bearing.

20

In the first variant of the second embodiment shown in Figure 14, both the blades 15 and the disc 10 of the impeller 9 are made from magnetized material. The borders between adjacent magnetized regions are indicated by dotted lines. The direction of rotation of the impeller 9 is indicated by an arrow.

25 Here again, the axially extending leading edges of the blades 15 are rounded or tapered so as to enhance the radial hydrodynamic bearing effect and reduce blood damage. In addition, the horizontal leading edges 24 of the blades 15 are also rounded or tapered to enhance the axial hydrodynamic bearing effect and reduce blood damage. Further in addition, although not

easy to recognize from the drawing, the upper and lower axial surfaces 25 of the blades are slightly tapered so as to provide a circumferentially extending ramp to create a hydrodynamic axial force lifting the impeller from the respective adjacent wall (not shown) upon rotation of the impeller. Similarly,
5 as has already been explained in connection with the first embodiment, the radially outer surfaces 22 of the blades 15 may likewise change from a smaller radius to a larger radius, as seen in the direction of rotation of the impeller, so as to form, together with the circular wall 12 or circularly arranged wall sections in the pump casing 1, radially converging clearance sections, so
10 as to enhance the radial hydrodynamic bearing effect on the impeller.

Figure 15 shows a second variant of the impeller 9 similar to that shown in Figure 14, except that the disc 10 and the blades 15 are composed of two semi-shells 26, 27 within which the magnets are housed. The semi-shells 26,
15 27 may be injection moulded.

Figure 16 shows a third variant of the impeller 9 of the second embodiment, similar to the variant shown in Figure 15. Here, two magnets are housed within each of the blades 15, the alternation of the north and south poles of the respective magnets being indicated with N and S. Again, alternatively
20 both the blades 15 and the disc 10 may be integrally formed from ferromagnetic material and magnetized in sections, as described above in relation to Figure 14.

25 Finally, a fourth variant of the impeller 9 of the second embodiment is shown in Figure 17. This variant is similar to the variant shown in Figure 14, except that the disc 10 is not necessarily made from a magnetized material. Here the disc 10 may instead be made of a polymer and has a plurality of circularly

arranged axial through openings into which the blades 15 are inserted so that they extend from one axial side of the disc 10 to the other axial side thereof.

In all variants of the second embodiment described above, the blades 15 may
5 have a different axial cross section, similar to one of those schematically shown in Figure 13. However, since only the upper and lower axial surfaces of the blades 15 contribute to the hydrodynamic axial bearing in the second embodiment, blades 15 with a large axial cross section are preferred.

10 Figure 18 shows an alternative upper shell 2' which differs from the upper shell 2' in Figure 5 in that the free-standing wall 12 has a greater thickness and the openings 13 are diverging in a radially outward direction. Alternatively (not shown), the free-standing wall 12 may be divided into an upper
15 circular wall section forming part of the upper shell 2 and a lower circular wall section of the lower shell 3, a continuous circular through opening being formed between the two circular wall sections. The continuous circular through opening also may have a diverging or increasing cross-section in a radial outward direction. The increasing cross section is illustrated in Figure
20 19 showing a cross sectional view of the wall of Figure 18 in an axial direction. The blood flows in the direction of the arrow. It is noted that, in case a wall with circumferentially spaced apart openings 13 is provided, the openings preferably also diverge as seen in a radial cross sectional view. The opening angle is 7° or less in order to avoid detachment of the flow. In this variant the openings 13 or the circular opening serve as a first diffuser
25 providing a pressure increase, i.e. an additional pump effect. The first diffuser may also stabilize the radial hydrodynamic bearing of the impeller by keeping the pressure along the circumference of the impeller constant. For this purpose the deceleration of the blood in the first diffuser may either be constant or may vary along the circumference of the circular wall 12, for in-

- 26 -

stance by varying the height, width and/or diameter of the openings 13 and/or the wall thickness (i.e. the length of the openings 13).

CLAIMS

1. A centrifugal blood pump without a mechanical bearing, comprising:
 - a pump casing (1) with a central axis, a blood flow inlet disposed on the
5 central axis and a blood flow outlet (21) disposed on a circumference of the pump casing,
 - an impeller (9) arranged in the pump casing so as to be rotatable about said central axis and freely movable axially and radially within a limited axial clearance and limited radial clearance, the impeller being provided
10 with permanent magnets or permanently magnetized magnetic regions (N/S) and further with radially extending blades (15) defining passages therebetween for radial blood flow, and
 - an electromagnetic drive (5) adapted to cooperate with the magnets or
15 magnetic regions (N/S) of the impeller so as to set the impeller rotating about said central axis,wherein said radial clearance is defined by an outer circumference (17, 18, 22) of the impeller and an inner surface of a wall (12), or a plurality of wall sections, arranged in a circle about said central axis within the pump casing, the radial clearance being 100 μm or less, preferably 50 μm or less and more
20 preferably 20 μm or less, so as to form a hydrodynamic radial bearing for the impeller.

2. The centrifugal blood pump according to claim 1, wherein the radial clearance comprises a plurality of radially converging clearance sections (14), as
25 seen in the direction of rotation of the impeller

3. The centrifugal blood pump according to claim 1 or 2, wherein the electromagnetic drive comprises a plurality of coils (5) without a ferromagnetic core, the coils being arranged in a plane axially spaced from the impeller (9).

- 28 -

4. The centrifugal blood pump according to any of claims 1 to 3, wherein the electromagnetic drive comprises a plurality of coils (5) arranged in a plane axially spaced from the impeller (9) on both sides of the impeller.
- 5
5. The centrifugal blood pump according to claim 3 or 4, wherein the coils (5) are potted in a polymer matrix.
6. The centrifugal blood pump according to any of claims 3 to 5, wherein the
10 coils (5) are directly or indirectly mounted on a ceramic plate (6) so as to form an integral component therewith, the ceramic plate limiting said axial clearance.
7. The centrifugal blood pump according to any of claims 1 to 6, wherein the
15 plurality of wall sections comprise an upper circular wall section and a lower circular wall section, the upper and lower circular wall sections being axially spaced apart so as to form one continuous circumferential through opening (13) for blood to flow from the impeller (9) towards the blood flow outlet (21).
- 20
8. The centrifugal blood pump according to any of claims 1 to 6, wherein said wall (12) or plurality of wall sections provide a plurality of circumferentially spaced through openings (13) for blood to flow from the impeller (9) towards the blood flow outlet (21), all distances between two adjacent through open-
25 ings (13) being smaller than all distances between adjacent radially outer ends of the impeller blades (15).
9. The centrifugal blood pump according to any of claims 1 to 8, wherein the impeller (9) comprises a first disc (10) and a second disc (10) which are axial-

ly spaced apart, each disc having magnetic regions and a central opening (7) arranged for axial blood flow through the first and second discs, the blades (15) of the impeller (9) being arranged between the discs (10).

5 10. The centrifugal blood pump according to claim 9, wherein the blades (15) are integrally connected by at least one circular rim (17, 18) axially extending from an axial side or both axial sides of the blades (15) and surrounding an outer circumference of at least one or both of said first and second discs (10),
10 said circular rim (17, 18) forming a part or all of said outer circumference of the impeller (9).

11. The centrifugal blood pump according to claim 9, wherein at least one or both of said first and second discs (10) have a circular outer circumference which forms a part or all of said outer circumference of the impeller (9).
15

12. The centrifugal blood pump according to any of claims 9 to 11, wherein surfaces of the first and second discs (10) which axially face away from each other are planar and are each axially spaced from an adjacent planar wall (6) so as to allow blood to flow between the planar disc surfaces and the adjacent
20 planar walls (6).

13. The centrifugal blood pump according to any of claims 9 to 11, wherein surfaces of the first and second discs (10) which axially face away from each other are each axially spaced from an adjacent wall (6) provided by or arranged in the pump casing (1) so as to allow blood to flow between the disc
25 surfaces and the adjacent walls, whereby one or both of the disc surfaces and/or one or both of the adjacent walls provide ramps extending about the central axis in a circumferential direction so as to create a hydrodynamic axi-

- 30 -

al force lifting the impeller from the respective adjacent wall (6) upon rotation of the impeller.

14. The centrifugal blood pump according to any of claims 1 to 6, wherein the
5 impeller (9) comprises a disc (10) with a central opening (7) arranged for axial blood flow through the disc and wherein the blades (15) of the impeller extend axially from both axial sides of the disc (10) and are formed as magnets or have magnetic regions (N/S).

10 15. The centrifugal blood pump according to claim 14, wherein said wall (12) or plurality of wall sections provide a plurality of circumferentially spaced apart through openings (13) for blood to flow from the impeller (9) towards the blood flow outlet (21), all distances between two adjacent through openings (13) being smaller than all distances between adjacent radially outer
15 ends of the impeller blades (15).

16. The centrifugal blood pump according to claim 14 or 15, wherein the disc (10) has a circular radially outer surface and wherein said wall extends radially inward so as to form together with the circular radially outer surface of
20 the disc said hydrodynamic radial bearing.

17. The centrifugal blood pump according to any of claims 14 to 16, wherein the impeller blades (15) have upper and lower surfaces (25) axially spaced from adjacent walls provided by or arranged in the pump casing (1) so as to
25 allow blood to flow between said upper and lower surfaces and the adjacent walls, either or both of said upper and lower surfaces providing ramps extending about the central axis in a circumferential direction so as to create a hydrodynamic axial force lifting the impeller from the respective adjacent wall upon rotation of the impeller.

18. The centrifugal blood pump according to claim 17, wherein the ramp of one or more of the upper and lower surfaces (25) of the impeller blades (15) is formed by a curved or tapered leading edge of the blade, as seen in the direction of rotation of the impeller, preferably passing into a straight section.

19. The centrifugal blood pump according to any of claims 14 to 18, wherein the disc (10) has a plurality of circularly arranged axial through openings and wherein the blades (15) are inserted through the circularly arranged through openings so as to extend from one axial side of the disc to the other axial side thereof.

20. The centrifugal blood pump according to claim 19, wherein the disc (10) comprises or is entirely made up of a polymer material.

21. The centrifugal blood pump according to any of claims 14 to 18, wherein the disc (10) and the blades (15) are composed of two semi-shells (26, 27) within which the magnets are housed.

22. The centrifugal blood pump according to any of claims 1 to 21, wherein the blades (15) of the impeller (9) are formed together as an integral injection moulded piece (11).

23. The centrifugal blood pump according to any of claims 14 to 19, wherein both the disc (10) and the blades (15) are made of magnetized ferromagnetic material.

24. The centrifugal blood pump according to any of claims 14 to 18, wherein the disc (10) and the blades (15) are formed as an integral piece of ferromagnetic material, said piece, including the disc (10), being magnetized.
- 5 25. The centrifugal blood pump according to any of claims 1 to 24, wherein the radial dimension of at least one or all of the impeller blades (15) increases circumferentially, radially outer surfaces (22) of these blades forming part or all of said outer circumference of the impeller (9).
- 10 26. The centrifugal blood pump according to any of claims 1 to 25, wherein the blades (15) of the impeller (9) have a leading surface (22a), as seen in the direction of rotation of the impeller, which is convex with respect to its radial extension.
- 15 27. The centrifugal blood pump according to any of claims 1 to 26, wherein the blades (15) of the impeller (9) have an axially extending leading edge (23), as seen in the direction of rotation of the impeller, which is curved or tapered.
- 20 28. The centrifugal blood pump according to any of claims 1 to 27, wherein the impeller (9) has an aspect ratio of 4 : 1 (diameter : height) or more, preferably 6 : 1 or more.
- 25 29. The centrifugal blood pump according to any of claims 1 to 28, wherein a first magnet or magnetic region and a second magnet or magnetic region, each having a north pole (N) and a south pole (S), are combined in one impeller blade (15), with the north and south poles of the first magnet or magnetic region being arranged upside down with respect to the north and south poles of the second magnet or magnetic region.

30. The centrifugal blood pump according to any of claims 1 to 29, wherein the magnets or magnetic regions are covered all over with a polymer or a metal, such as titanium or a biocompatible precious metal, the coating preferably having a thickness of no more than 50 μm .

31. The centrifugal blood pump according to any of claims 1 to 30, wherein the blood flow outlet (21) is tangentially disposed on the pump casing's circumference.

10

32. The centrifugal blood pump according to any of claims 1 to 31, comprising a ring diffuser (20) arranged peripherally of said wall (12) or wall sections.

33. The centrifugal blood pump according to any of claims 1 to 32, wherein said wall (12) or plurality of wall sections provide a plurality of circumferentially spaced apart through openings (13) or a ring-like opening for blood to flow from the impeller (9) towards the blood flow outlet (21), a cross-section of the through openings (13) or the ring-like opening increasing in a radially outward direction.

20

34. The centrifugal blood pump according to claim 33, wherein an opening angle of the through openings (13) or the ring-like opening does not exceed 7° .

25

35. The centrifugal blood pump according to claim 33 or 34, wherein the wall (12) or plurality of wall sections have a thickness of at least 2 mm.

- 34 -

36. The centrifugal blood pump according to any of claims 33 to 35, wherein the through openings (13) have a different height, width or diameter.
- 5 37. The centrifugal blood pump according to any of claims 33 to 36, wherein the thickness of the wall (12) varies along the circumference of the wall (12).

FIG 1

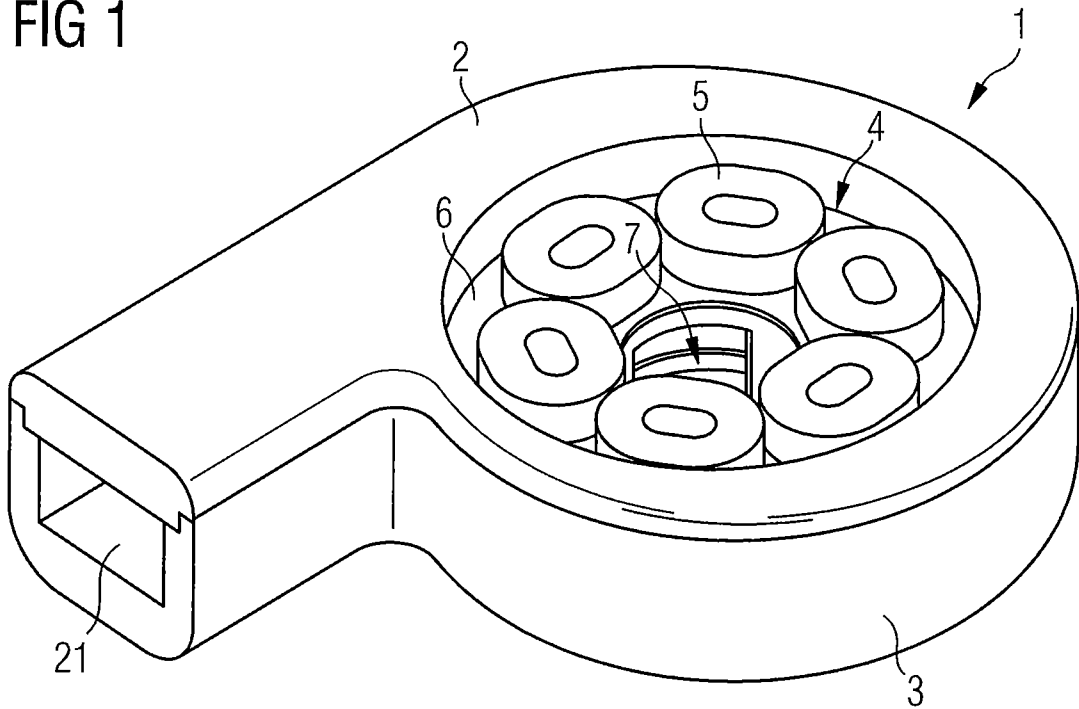

FIG 2

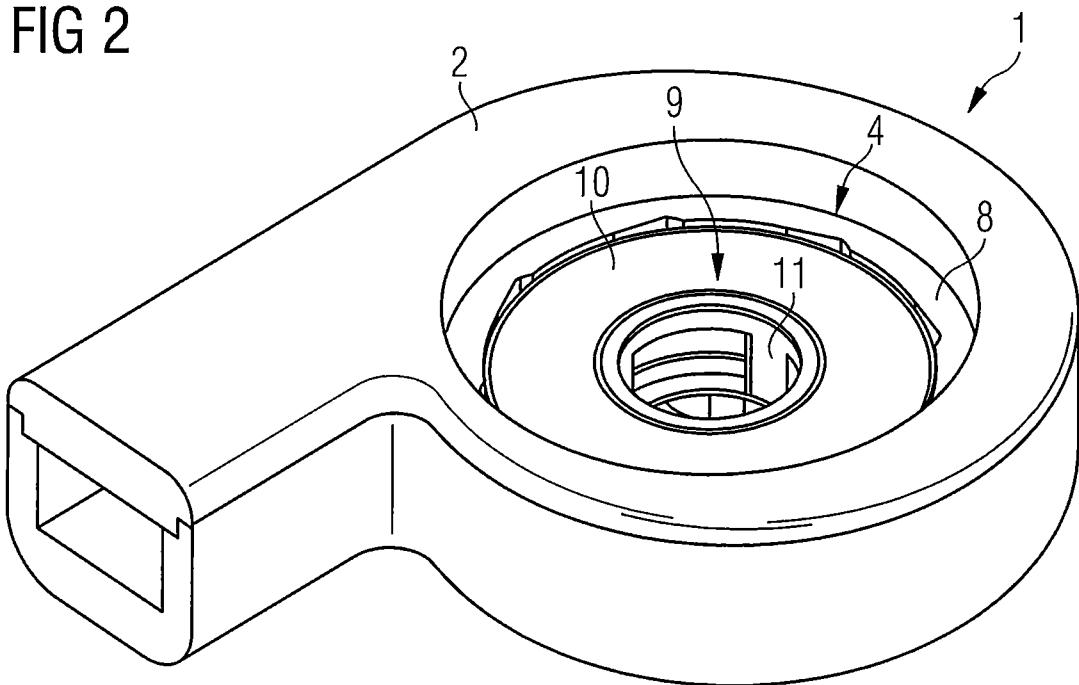

FIG 3

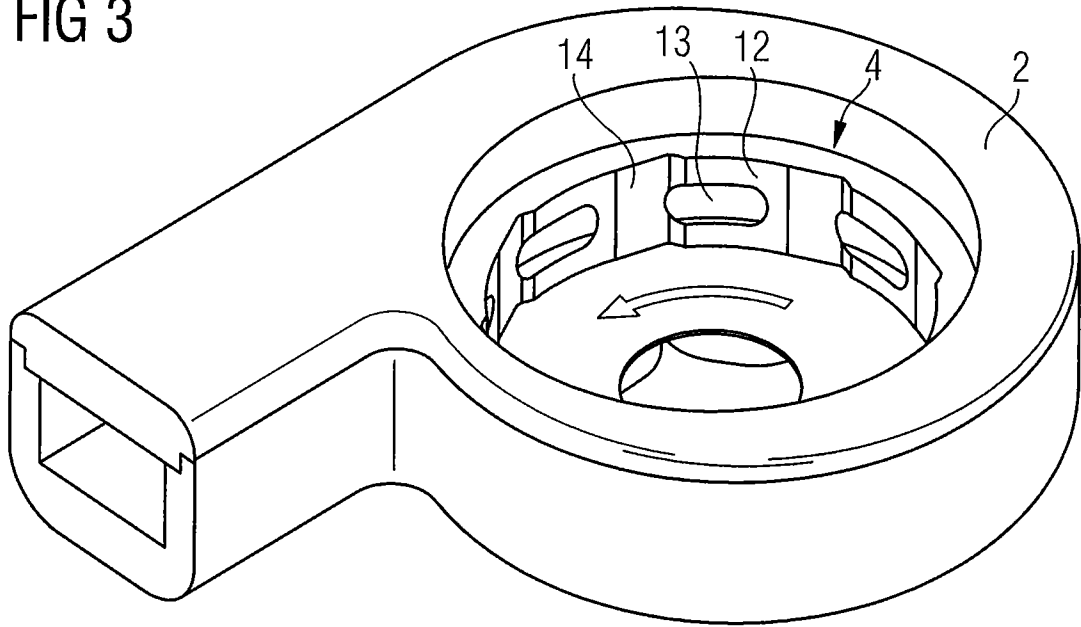

FIG 4

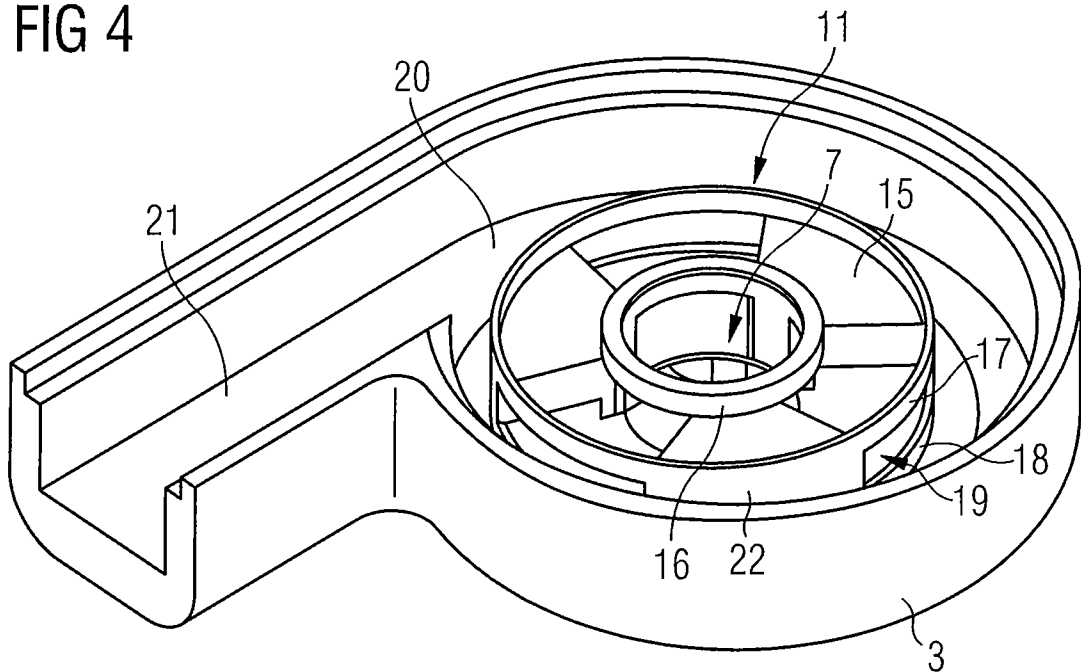

FIG 5

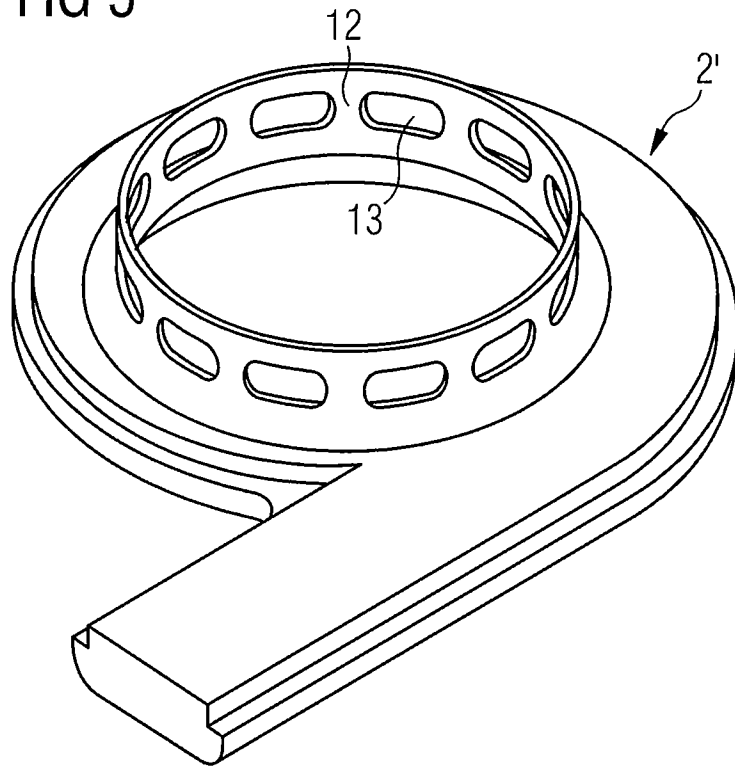
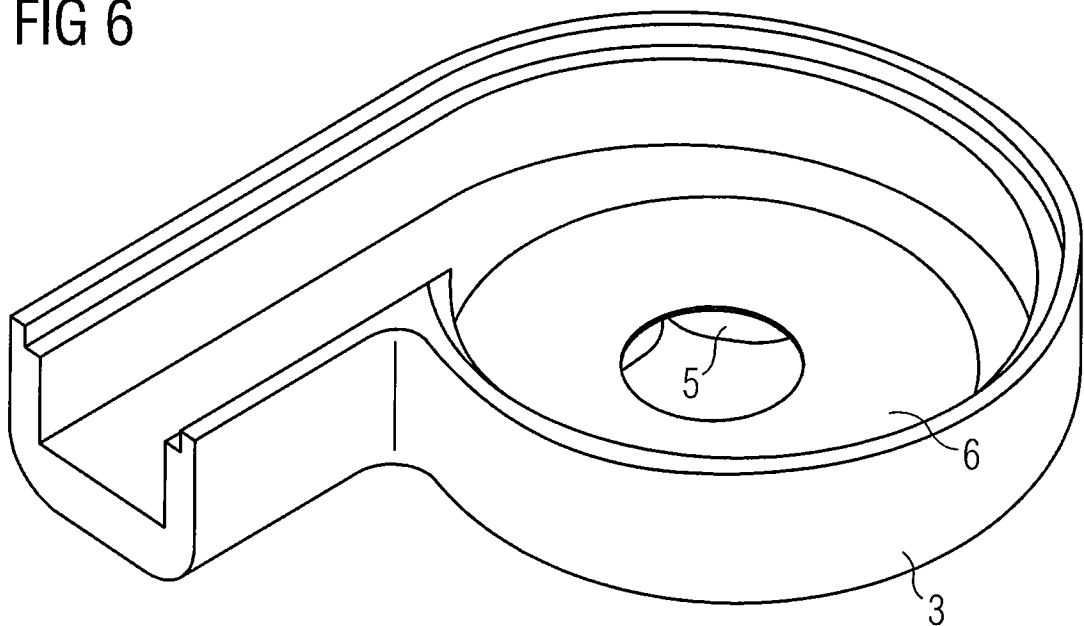

FIG 6



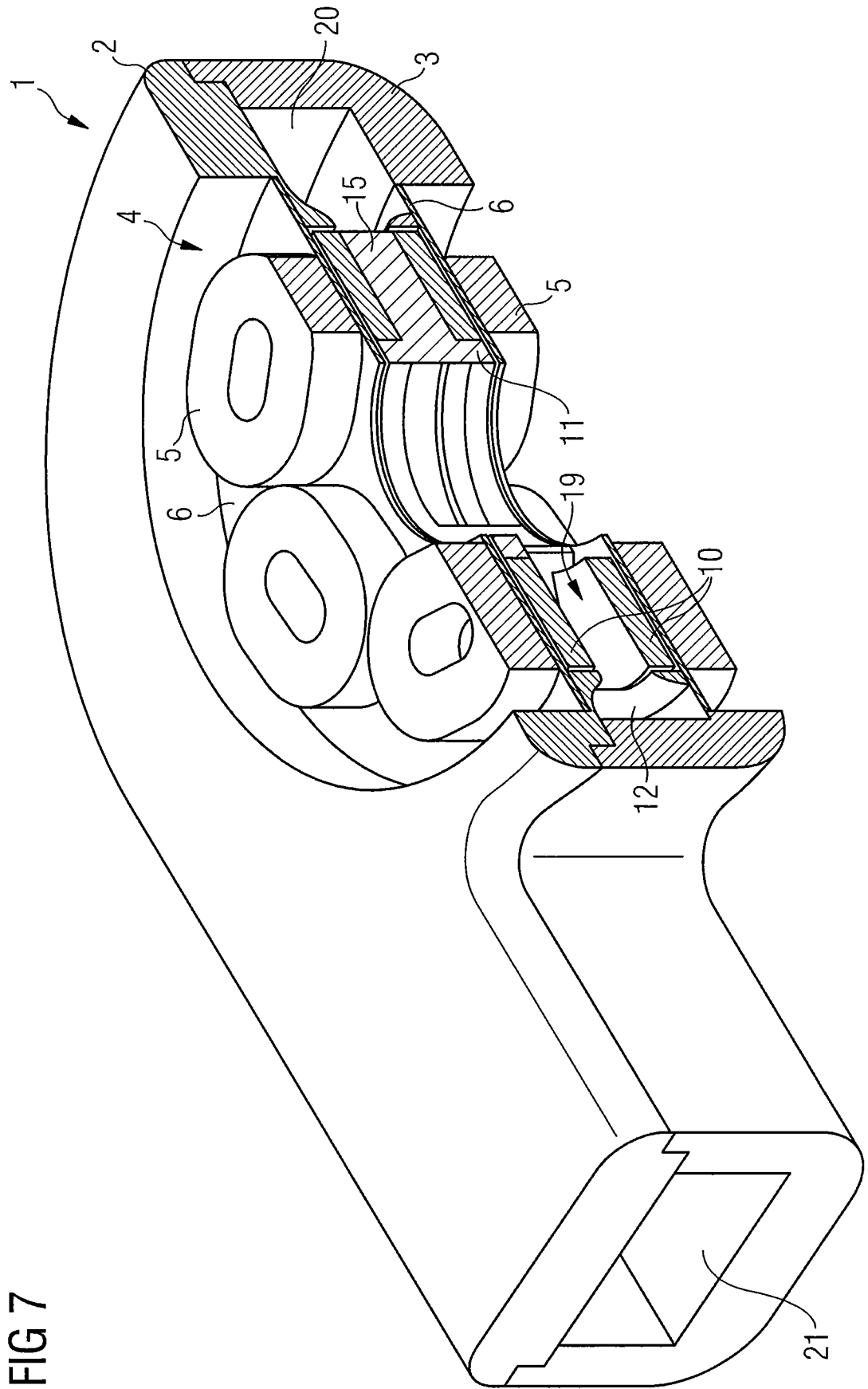

FIG 7

FIG 8

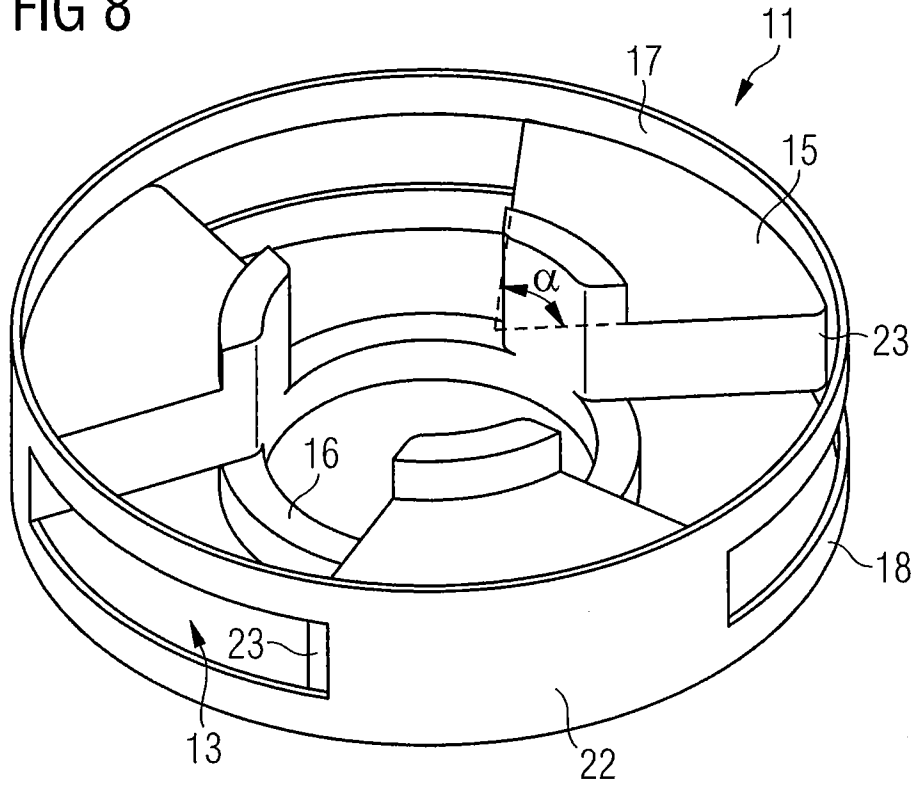

FIG 9

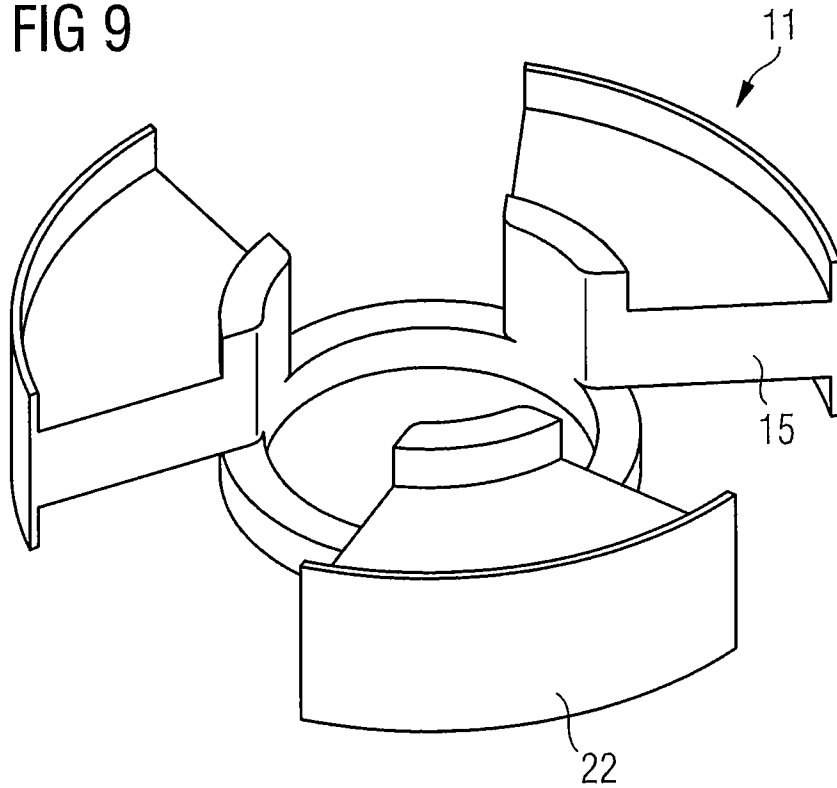

FIG 10

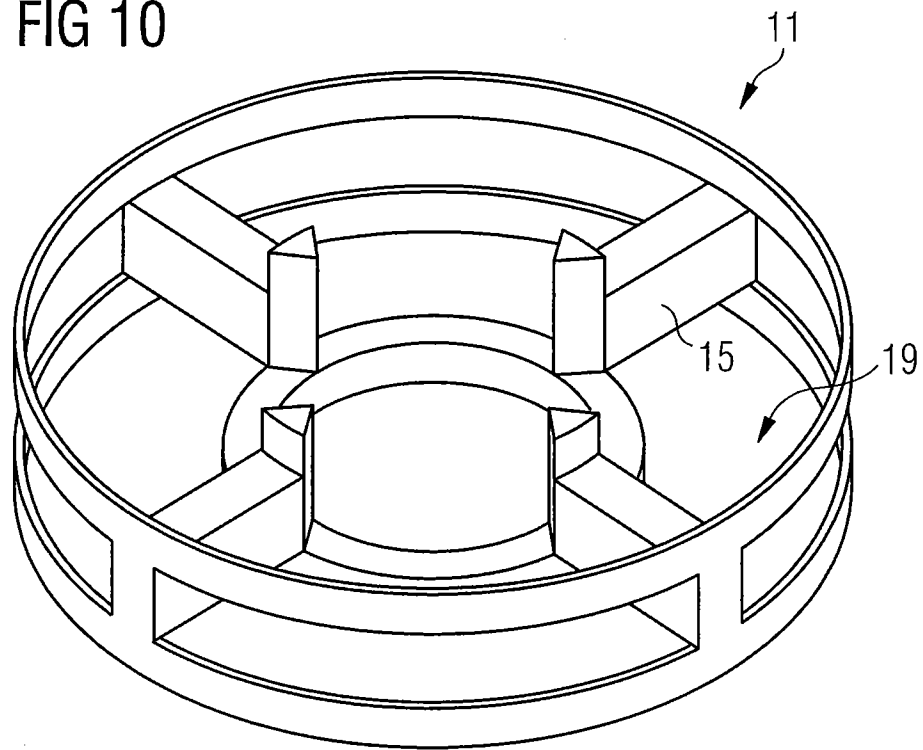

FIG 11

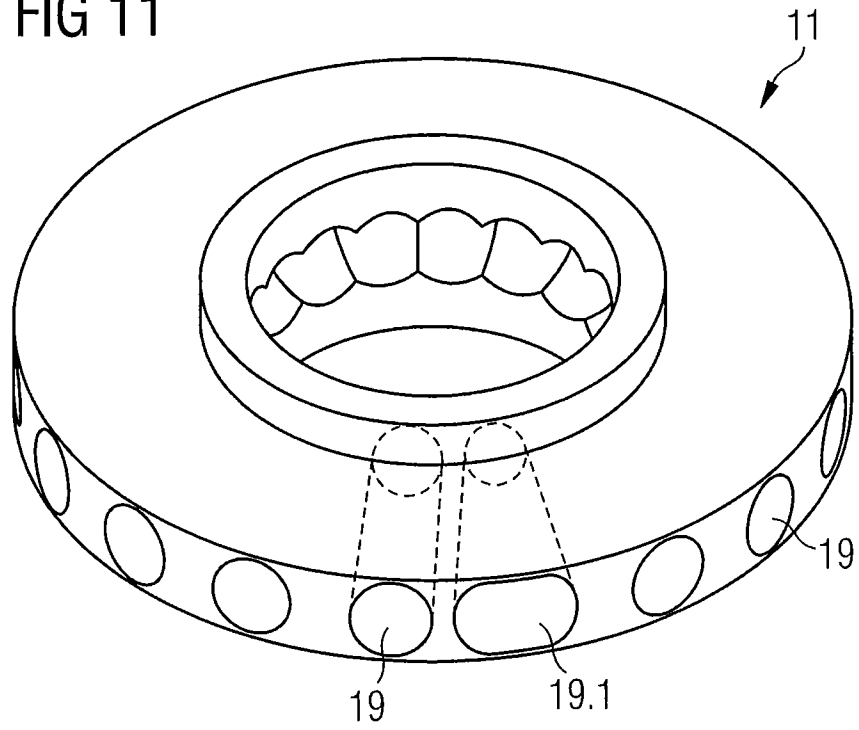

FIG 12

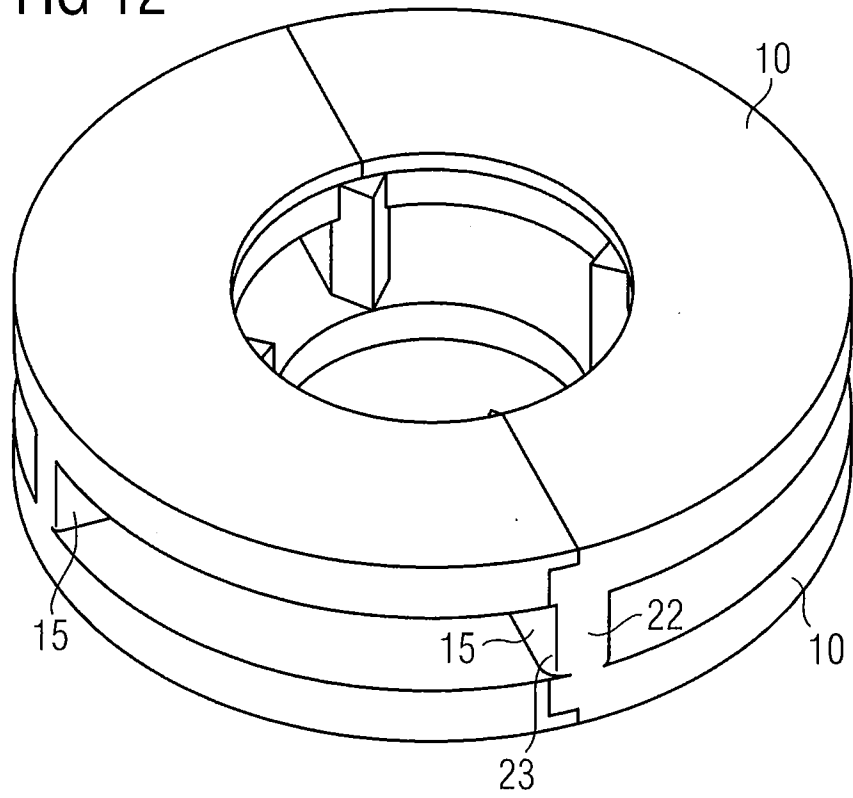

FIG 13

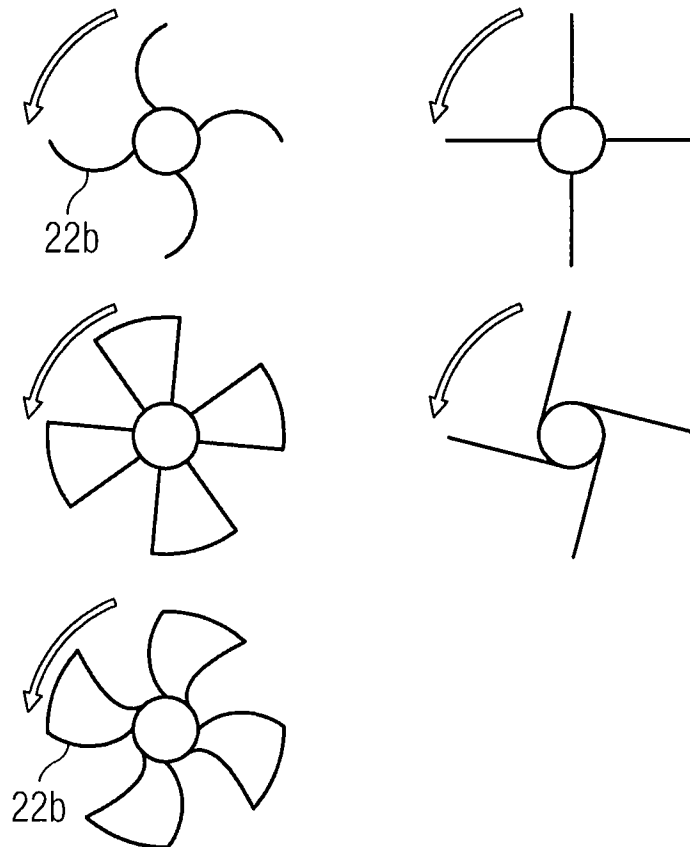

FIG 14

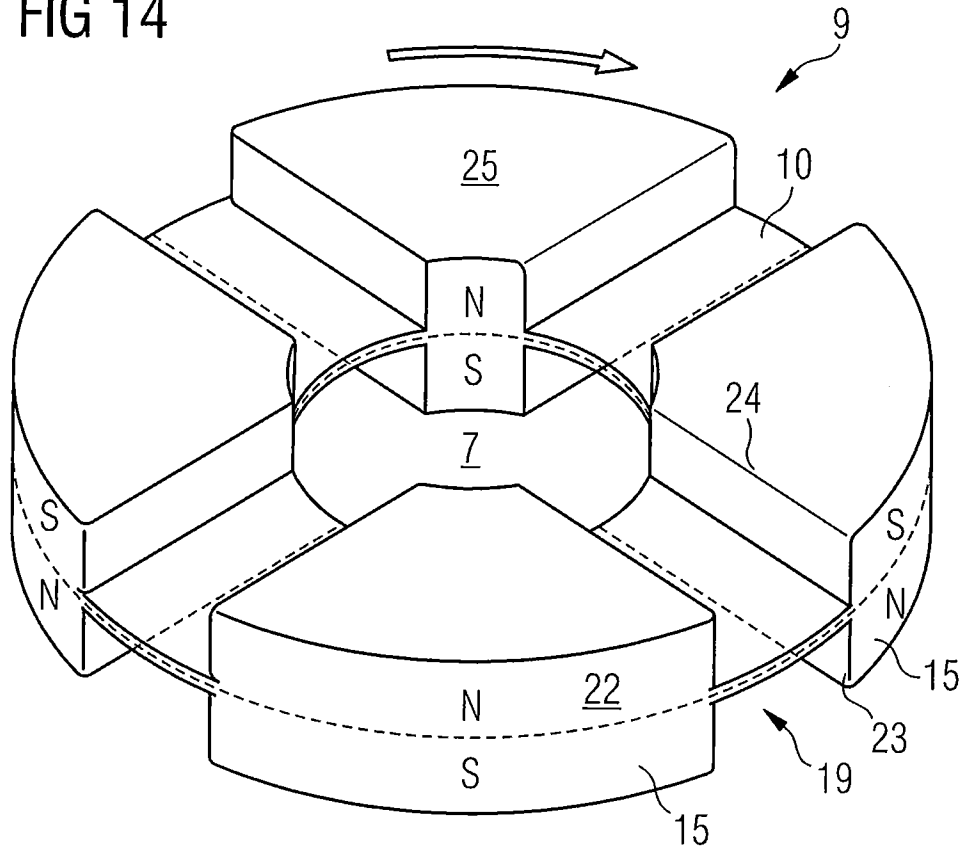

FIG 15

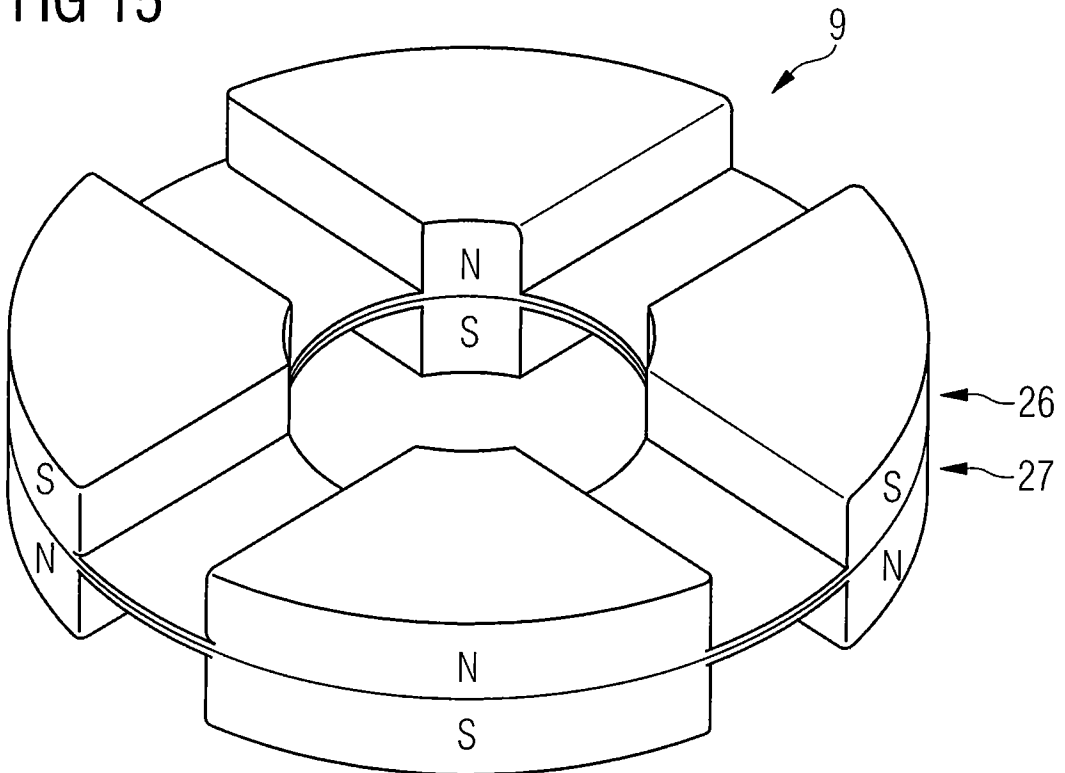

FIG 16

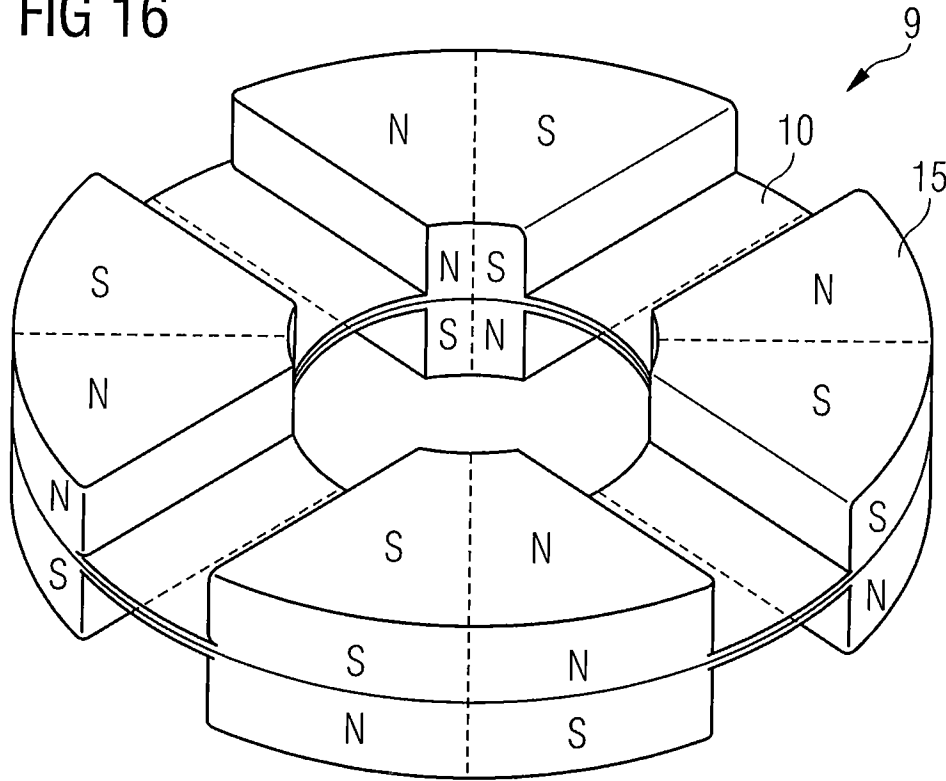

FIG 17

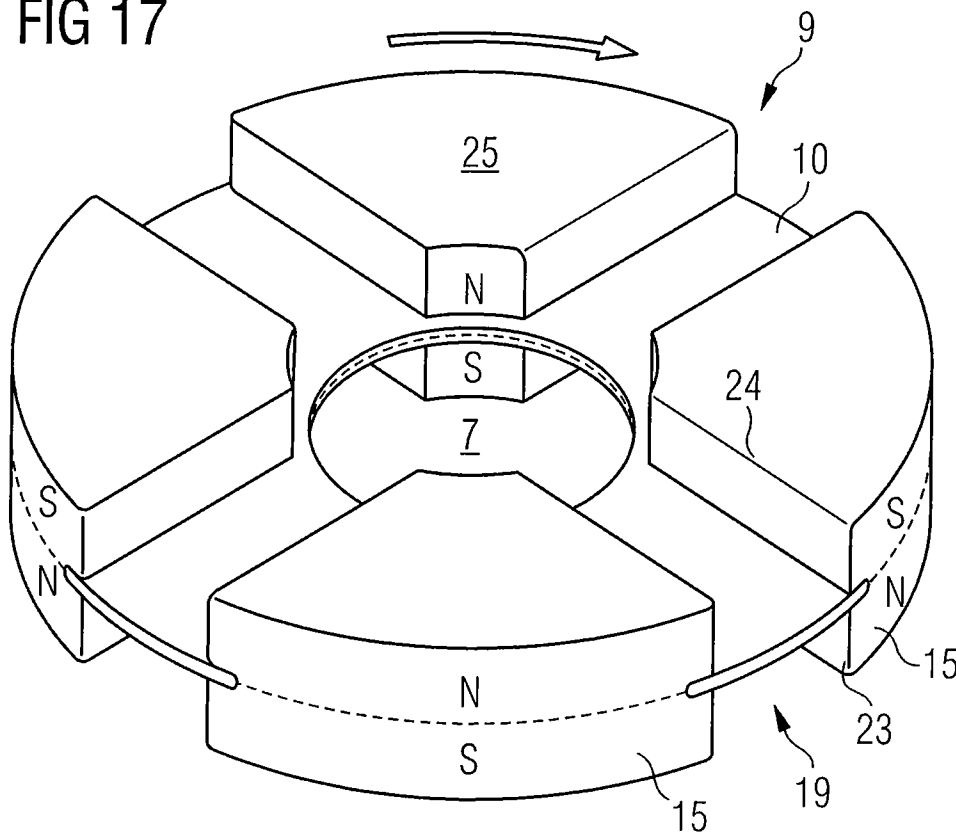

FIG 18

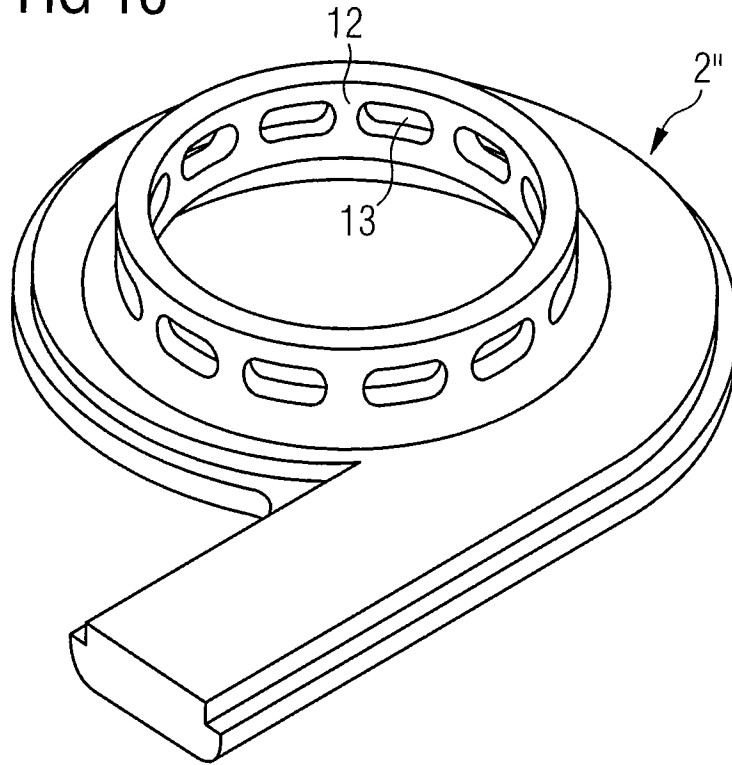
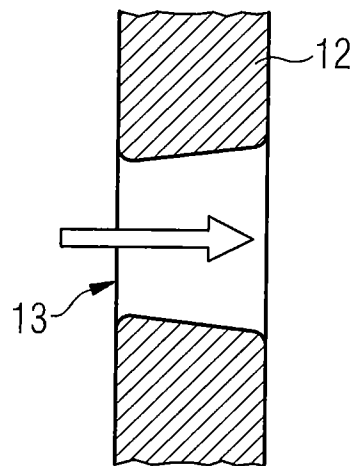

FIG 19



INTERNATIONAL SEARCH REPORT

International application No
PCT/EP2013/071273

A. CLASSIFICATION OF SUBJECT MATTER
INV. A61M1/10
ADD.
According to International Patent Classification (IPC) or to both national classification and IPC

B. FIELDS SEARCHED
Minimum documentation searched (classification system followed by classification symbols)
A61M

Documentation searched other than minimum documentation to the extent that such documents are included in the fields searched

Electronic data base consulted during the international search (name of data base and, where practicable, search terms used)
EPO-Internal, WPI Data

C. DOCUMENTS CONSIDERED TO BE RELEVANT

| Category* | Citation of document, with indication, where appropriate, of the relevant passages | Relevant to claim No. |
|-----------|--|-----------------------------|
| X | US 2001/002234 A1 (WOODARD JOHN C [AU] ET AL) 31 May 2001 (2001-05-31) | 1-7,14, 16, 19-27, 30-35,37 |
| Y | paragraphs [0071] - [0130], [0145] figures 1-3, 7, 11, 20 | 8-13,15, 17,18, 28,29,36 |
| Y | ----- US 2012/253103 A1 (ROBERT JARVIK MD [US] ROBERT JARVIK [US]) 4 October 2012 (2012-10-04) | 8,15,36 |
| A | paragraphs [0035], [0036] figure 6 ----- -/-- | 1 |

Further documents are listed in the continuation of Box C.

See patent family annex.

* Special categories of cited documents :

- "A" document defining the general state of the art which is not considered to be of particular relevance
- "E" earlier application or patent but published on or after the international filing date
- "L" document which may throw doubts on priority claim(s) or which is cited to establish the publication date of another citation or other special reason (as specified)
- "O" document referring to an oral disclosure, use, exhibition or other means
- "P" document published prior to the international filing date but later than the priority date claimed

- "T" later document published after the international filing date or priority date and not in conflict with the application but cited to understand the principle or theory underlying the invention
- "X" document of particular relevance; the claimed invention cannot be considered novel or cannot be considered to involve an inventive step when the document is taken alone
- "Y" document of particular relevance; the claimed invention cannot be considered to involve an inventive step when the document is combined with one or more other such documents, such combination being obvious to a person skilled in the art
- "&" document member of the same patent family

| | |
|---|--|
| Date of the actual completion of the international search 7 January 2014 | Date of mailing of the international search report 15/01/2014 |
|---|--|

| | |
|--|---|
| Name and mailing address of the ISA/ European Patent Office, P.B. 5818 Patentlaan 2 NL - 2280 HV Rijswijk Tel. (+31-70) 340-2040, Fax: (+31-70) 340-3016 | Authorized officer Schlaug, Martin |
|--|---|

INTERNATIONAL SEARCH REPORT

International application No
PCT/EP2013/071273

| C(Continuation). DOCUMENTS CONSIDERED TO BE RELEVANT | | |
|--|--|-----------------------|
| Category* | Citation of document, with indication, where appropriate, of the relevant passages | Relevant to claim No. |
| Y | EP 1 598 087 A2 (TERUMO CORP [JP]; NTN TOYO BEARING CO LTD [JP]) 23 November 2005 (2005-11-23) | 9-13,28 |
| A | paragraphs [0033], [0109] - [0111] figures 24, 25 ----- | 1 |
| Y | WO 2008/136979 A1 (HEARTWARE INC [US]) 13 November 2008 (2008-11-13) | 13,17,18 |
| A | paragraph [0072] figure 11 ----- | 1 |
| Y | WO 00/64508 A1 (KRITON MEDICAL INC [US]; WAMPLER RICHARD K [US]; LANCISI DAVID M [US]) 2 November 2000 (2000-11-02) | 29 |
| A | page 8, line 3 - page 10, line 14 page 12, lines 3-9 figures 3, 4, 10, 10a ----- | 1 |
| A | US 6 623 475 B1 (SIESS THORSTEN [DE]) 23 September 2003 (2003-09-23) cited in the application column 4, lines 23-59 figures 5-7 ----- | 1 |
| A | EP 1 495 773 A2 (TERUMO CORP [JP]) 12 January 2005 (2005-01-12) paragraph [0053] figure 9 ----- | 1 |

INTERNATIONAL SEARCH REPORT

Information on patent family members

International application No

PCT/EP2013/071273

| Patent document cited in search report | Publication date | Patent family member(s) | Publication date |
|--|------------------|-------------------------|-----------------------------|
| US 2001002234 | A1 | 31-05-2001 | US 2001002234 A1 31-05-2001 |
| | | | US 2002018713 A1 14-02-2002 |
| | | | US 2004028525 A1 12-02-2004 |
| | | | US 2005281685 A1 22-12-2005 |
| ----- | | | |
| US 2012253103 | A1 | 04-10-2012 | US 2012253103 A1 04-10-2012 |
| | | | WO 2012135495 A1 04-10-2012 |
| ----- | | | |
| EP 1598087 | A2 | 23-11-2005 | AT 456963 T 15-02-2010 |
| | | | EP 1598087 A2 23-11-2005 |
| | | | US 2005287022 A1 29-12-2005 |
| | | | US 2010221130 A1 02-09-2010 |
| ----- | | | |
| WO 2008136979 | A1 | 13-11-2008 | EP 2145108 A1 20-01-2010 |
| | | | JP 2010525871 A 29-07-2010 |
| | | | US 2009234447 A1 17-09-2009 |
| | | | WO 2008136979 A1 13-11-2008 |
| ----- | | | |
| WO 0064508 | A1 | 02-11-2000 | AT 446778 T 15-11-2009 |
| | | | AU 773136 B2 20-05-2004 |
| | | | AU 4330200 A 10-11-2000 |
| | | | CA 2370740 A1 02-11-2000 |
| | | | EP 1173238 A1 23-01-2002 |
| | | | ES 2334633 T3 15-03-2010 |
| | | | JP 4184611 B2 19-11-2008 |
| | | | JP 2002541985 A 10-12-2002 |
| | | | US 6234772 B1 22-05-2001 |
| | | | WO 0064508 A1 02-11-2000 |
| ----- | | | |
| US 6623475 | B1 | 23-09-2003 | AT 281191 T 15-11-2004 |
| | | | AU 1554000 A 19-06-2000 |
| | | | CA 2349483 A1 08-06-2000 |
| | | | DE 29821565 U1 15-06-2000 |
| | | | EP 1135182 A1 26-09-2001 |
| | | | JP 4018342 B2 05-12-2007 |
| | | | JP 2002531184 A 24-09-2002 |
| | | | US 6623475 B1 23-09-2003 |
| | | | WO 0032256 A1 08-06-2000 |
| ----- | | | |
| EP 1495773 | A2 | 12-01-2005 | AT 422914 T 15-03-2009 |
| | | | EP 1495773 A2 12-01-2005 |
| | | | JP 4308723 B2 05-08-2009 |
| | | | JP 2005028137 A 03-02-2005 |
| | | | US 2005008496 A1 13-01-2005 |
| ----- | | | |