



- (51) International Patent Classification: *B60S 1/38* (2006.01)
- (21) International Application Number: PCT/EP2011/055787
- (22) International Filing Date: 13 April 2011 (13.04.2011)
- (25) Filing Language: English
- (26) Publication Language: English
- (71) Applicant (for all designated States except US): **FEDERAL-MOGUL S.A.** [BE/BE]; Avenue Champion, B-6790 Aubange (BE).
- (72) Inventors; and
- (75) Inventors/Applicants (for US only): **BOUDJENAH, Daniel** [BE/BE]; 10 Route de St. Walfroy, B-08370 Mar-gut (BE). **ROUSSEL, Gerald** [BE/BE]; Rue des Chas-seurs Ardennais, 135, B-6730 St. Vincent (BE).

- (74) Agents: **HOOIVELD, Arjen Jan Winfried** et al.; Sweelinckplein 1, NL-2517 GK Den Haag (NL).
- (81) Designated States (unless otherwise indicated, for every kind of national protection available): AE, AG, AL, AM, AO, AT, AU, AZ, BA, BB, BG, BH, BR, BW, BY, BZ, CA, CH, CL, CN, CO, CR, CU, CZ, DE, DK, DM, DO, DZ, EC, EE, EG, ES, FI, GB, GD, GE, GH, GM, GT, HN, HR, HU, ID, IL, IN, IS, JP, KE, KG, KM, KN, KP, KR, KZ, LA, LC, LK, LR, LS, LT, LU, LY, MA, MD, ME, MG, MK, MN, MW, MX, MY, MZ, NA, NG, NI, NO, NZ, OM, PE, PG, PH, PL, PT, RO, RS, RU, SC, SD, SE, SG, SK, SL, SM, ST, SV, SY, TH, TJ, TM, TN, TR, TT, TZ, UA, UG, US, UZ, VC, VN, ZA, ZM, ZW.
- (84) Designated States (unless otherwise indicated, for every kind of regional protection available): ARIPO (BW, GH, GM, KE, LR, LS, MW, MZ, NA, SD, SL, SZ, TZ, UG, ZM, ZW), Eurasian (AM, AZ, BY, KG, KZ, MD, RU, TJ, TM), European (AL, AT, BE, BG, CH, CY, CZ, DE, DK, EE, ES, FI, FR, GB, GR, HR, HU, IE, IS, IT, LT, LU, LV, MC, MK, MT, NL, NO, PL, PT, RO, RS, SE, SI, SK, SM,

[Continued on next page]

(54) Title: WINDSCREEN WIPER DEVICE

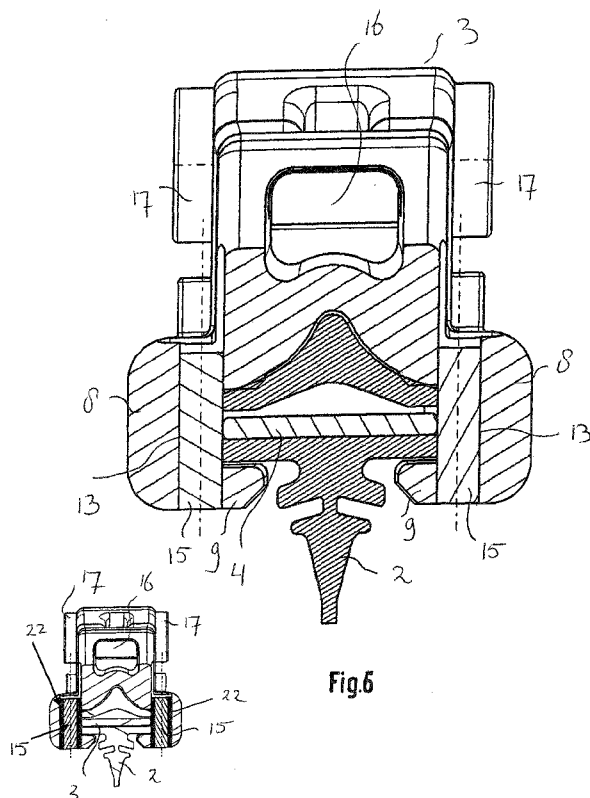

(57) Abstract: A windscreen wiper device (1) of the flat blade type, comprising an elongated wiper blade (2) of a flexible material including at least one longitudinal groove, in which at least one longitudinal strip (4) is disposed and comprising a connecting device (5) for an oscillating arm, being connected to the flexible material of said wiper blade by at least one pin (14), wherein said pin cooperates with a recess (21) provided along an exterior edge of said longitudinal strip in order to block any movement of said wiper blade in longitudinal direction thereof relative to said longitudinal strip at the location of the interconnection of said connecting device and said wiper blade, wherein said pin allows a movement of said longitudinal strip in upward and downward direction at least substantially perpendicular to the windscreen to be wiped.

TR), OAPI (BF, BJ, CF, CG, CI, CM, GA, GN, GQ, GW, ML, MR, NE, SN, TD, TG). **Published:**

— with international search report (Art. 21(3))

WINDSCREEN WIPER DEVICE

5 The present invention relates to a windscreen wiper device of the flat blade type, particularly for automobiles, comprising an elastic, elongated carrier element, as well as an elongated wiper blade of a flexible material, which can be placed in abutment with a windscreen to be wiped, which
10 wiper blade includes at least one longitudinal groove, in which groove at least one longitudinal strip of the carrier element is disposed, which windscreen wiper device comprises a connecting device for an oscillating arm, wherein said oscillating arm can be pivotally connected to said
15 connecting device about a pivot axis near one end thereof. Particularly, said oscillating arm can be pivotally connected to said connecting device with the interposition of a joint part. More in particular, said wiper blade comprises a spoiler at a side thereof facing away from the
20 windscreen to be wiped. Said longitudinal groove is preferably a central longitudinal groove accommodating said longitudinal strip. Said longitudinal strip is also called a "flexor", while said connecting device is also indicated as a "connector". In the framework of the present invention
25 said connector is preferably made in one piece, also called a "one piece connector".

Such a windscreen wiper device is generally known. This prior art windscreen wiper device is designed as a so-called
30 "flat blade" or "yokeless blade", wherein no use is made of several yokes pivotally connected to each other, but wherein the wiper blade is biased by the carrier element, as a

result of which it exhibits a specific curvature. The spoiler is also called an "air deflector".

The object of the invention is to provide an improved
5 windscreen wiper device.

In order to accomplish that objective, a windscreen wiper device of the type referred to in the introduction is characterized according to the invention in that said
10 connecting device is connected to the flexible material of said wiper blade by at least one pin, wherein said pin cooperates with a recess provided along an exterior edge of said longitudinal strip in order to block any movement of said wiper blade in longitudinal direction thereof relative
15 to said longitudinal strip at the location of the interconnection of said connecting device and said wiper blade, wherein said pin allows a movement of said longitudinal strip in upward and downward direction at least perpendicular to the windscreen to be wiped. Advantageously,
20 at least two of such pins are provided on opposite sides of said longitudinal strip, wherein said pins are preferably located opposite one another. In a preferred embodiment said connecting device is connected to the flexible material of said wiper blade by said at least one pin being of the first
25 type and at least one pin of a second type, wherein said pin of the second type is mounted through the flexible material of said wiper blade at the location of the interconnection of said connecting device and said wiper blade in order to block any lateral movement of longitudinal strip at the
30 location of the interconnection of said connecting device and said wiper blade, and wherein said pins of the first and of the second type allow a movement of said longitudinal

strip in upward and downward direction at least substantially perpendicular to the windscreen to be wiped. In other words, said pin of the first type ensures that the wiper blade and the longitudinal strip are not allowed to mutually move under the connecting device, but particularly in all other areas along the wiper blade a slight movement thereof is made possible in order to allow said wiper blade to follow any curvature of the windscreen to be wiped. It is this interaction between the pin of the first type and the wiper blade that elastomeric material (i.e. usually rubber) of said wiper blade and material of the longitudinal strip (i.e. usually steel) are forced to engage with each other in a locking manner when the connecting device is finally mounted onto the wiper blade, all at the location under the connecting device. Said pin of the second type ensures that the so-called "fishtailing phenomenon" is avoided at all times. Said wiper blade at the location outside said connecting device would normally suffer from this "fishtailing phenomenon", wherein said wiper blade on opposite sides of said connecting device vibrates in an uncontrollable manner parallel to the windscreen to be wiped. Obviously, the "fishtailing phenomenon" results in deteriorated wiping properties, with all negative consequences involved, particularly at high speeds. Said pin of the second type going through the material of said wiper blade is realized at the time of mounting the connecting device onto the wiper blade during assembly of all relevant parts of the wiper blade, wherein said going through is particularly effected in a side region of the wiper blade, without having any influence on a bottom region thereof (i.e. containing a wiping lip of the wiper blade). Consequently, wiping properties of said wiper blade are not adversely affected. By allowing the longitudinal strip to

move in upward and downward direction perpendicular to the
windscreen to be wiped against the resiliency of the
flexible material of the wiper blade, the wiper blade is
optimally capable to follow any curvature of the windscreen
5 to be wiped, thereby enhancing the wiping properties. Said
connecting device is preferably in one piece.

It is noted that the present invention is not restricted to
the use of only one longitudinal strip forming the elastic
10 carrier element that is particularly located in a central
longitudinal groove of the wiper blade. Instead, said
carrier element may also comprise two longitudinal strips,
wherein said strips are disposed in opposite longitudinal
grooves of the wiper blade. Said groove(s) may be closed at
15 one outer end.

In a preferred embodiment of a windscreen wiper device in
accordance with the invention said pin of the first type
allows movement of said wiper blade in longitudinal
20 direction thereof relative to said longitudinal strip
outside the location of the interconnection of said
connecting device and said wiper blade. Hence, it is made
possible to allow said wiper blade to follow any curvature
of the windscreen to be wiped.

25

In another preferred embodiment of a windscreen wiper device
according to the invention said pins of the first and of the
second type are stamped through the flexible material of
said wiper blade. Preferably, said pin of the second type
30 exerts a transverse force on said longitudinal strip in
order to block any lateral movement of longitudinal strip at
the location of the interconnection of said connecting
device and said wiper blade. Preferably, no other force than

said transverse force is exerted by said pin of the second type.

In another preferred embodiment of a windscreen wiper device
5 in accordance with the invention said pin of the first type
and said pin of the second type are separate, i.e. single
constructional elements extending in mounted position at
least substantially perpendicular to the windscreen to be
wiped. Said pins of the first and of the second type are
10 preferably sharpened in order to cut through the flexible
material of said wiper blade. The pins of the first and of
the second type are particularly identical in shape and
size.

15 In another preferred embodiment of a windscreen wiper device
according to the invention said connecting device has a
substantially U-shaped cross-section, wherein free ends of
legs of said U-shaped cross-section extend inwardly so as to
form grooves for receiving longitudinal sides of said wiper
20 blade, and wherein said free ends are provided with holes,
preferably through holes, for receiving said pins of the
first type and of the second type. Particularly, said
connecting device is connected to the flexible material of
said wiper blade by one pin of the first type
25 interconnecting said connecting device and said wiper blade
(by inserting it into a hole of said connecting device) near
the middle longitudinal plane of said connecting device
perpendicular to the windscreen to be wiped and by two pairs
of opposite pins of the second type interconnecting said
30 connecting device and said wiper blade (by inserting them
into holes of said connecting device) near the outer ends of
said connecting device. More in particular, said connecting
device is connected to the flexible material of said wiper

blade by one pair of opposite pins of the first type
interconnecting said connecting device and said wiper blade
near the middle longitudinal plane of said connecting device
perpendicular to the windscreen to be wiped and by two pairs
5 of opposite pins of the second type interconnecting said
connecting device and said wiper blade near the outer ends
of said connecting device. Even more in particular, said
connecting device is connected to the flexible material of
said wiper blade by one pair of opposite pins of the first
10 type and by one pair of opposite pins of the second type
interconnecting said connecting device and said wiper blade
near the outer ends of said connecting device. Even more in
particular, said connecting device is connected to the
flexible material of said wiper blade by two pairs of
15 opposite pins of the first type interconnecting said
connecting device and said wiper blade near the outer ends
of said connecting device.

In another preferred embodiment of a windscreen wiper device
20 in accordance with the invention said connecting device is
pivotally connected to said oscillating arm with the
interposition of a joint part, wherein said joint part is
detachably connected to said connecting device by engaging
protrusions of said connecting device, at the location of
25 said pivot axis, in recesses provided in said joint part.
This is preferably realized through a snapping or clipping
operation.

In another preferred embodiment of a windscreen wiper device
30 according to the invention said joint part has an at least
substantially U-shaped cross-section at the location of its
connection to said connecting device, wherein said joint
part is provided with a recess provided coaxially with said

pivot axis. In particular, the protrusions extend outwards on either side of said connecting device and are preferably cylindrical in shape. In the alternative, said protrusions are spherical or frusto-conical in shape. Said protrusions that function as bearing surfaces are thus spaced far apart, 5 so that forces exerted thereon will be relatively low. In yet another preferred variant said joint part is provided with co-axial through holes in legs of said U-shaped cross-section thereof, wherein a pivot pin is inserted in said 10 through holes.

In another preferred embodiment of a windscreen wiper device in accordance with the invention said protrusions are provided with co-axial through holes. Accordingly, the wiper 15 blade may then be connected to the oscillating arm on the basis of a so-called "sidelock system". The oscillating arm is provided with a joint pin or a pivot pin to be inserted in said co-axial through holes. Said pivot pin protrudes in a direction towards the wiper blade and has a pivot axis 20 extending in a direction of the oscillating movement of the oscillating arm.

In another preferred embodiment of a windscreen wiper device according to the invention said joint part comprises at 25 least one resilient tongue engaging in a correspondingly shaped hole provided in a base of a U-shaped cross-section of said oscillating arm, and wherein said resilient tongue is rotatable along a hinge axis between an outward position retaining said wiper blade onto said oscillating arm and an 30 inward position releasing said wiper blade from said oscillating arm. Accordingly, the wiper blade may then be connected to the oscillating arm on the basis of a so-called "toplock system" on the basis of a bayonet connection. In

order to connect the wiper blade onto the oscillating arm, the resilient tongue is initially pushed in against a spring force - as if it were a push button - and then allowed to spring back into the hole provided in the oscillating arm, thus snapping, that is clipping the resilient tongue into the hole. By subsequently pushing in again the resilient tongue against the spring force, the wiper blade may be released from the oscillating arm.

10 The present invention also refers to a method for manufacturing a windscreen wiper device of the flat blade type, particularly for automobiles, comprising an elastic, elongated carrier element, as well as an elongated wiper blade of a flexible material, which can be placed in
15 abutment with a windscreen to be wiped, which wiper blade includes at least one longitudinal groove, in which groove at least one longitudinal strip of the carrier element is disposed, which windscreen wiper device comprises a connecting device for an oscillating arm, wherein said
20 oscillating arm can be pivotally connected to said connecting device about a pivot axis near one end thereof, characterized in that first a recess is cut along an exterior edge of said longitudinal strip, wherein said connecting device is subsequently mounted onto said wiper
25 blade, wherein said longitudinal strip is subsequently inserted inside said groove, whereinafter at least one pin of the first type and at least one pin of the second type are used, wherein

- first said pin of the second type is used, said pin of
30 the second type being mounted through the flexible material of said wiper blade at the location of the interconnection of said connecting device and said wiper blade in order to block any lateral movement of

longitudinal strip at the location of the interconnection of said connecting device and said wiper blade;

- secondly said pin of the first type is used, said pin of the first type cooperating with said recess provided along said exterior edge of said longitudinal strip in order to block any movement of said wiper blade in longitudinal direction thereof relative to said longitudinal strip at the location of the interconnection of said connecting device and said wiper blade; and
- said pins of the first and of the second type allow a movement of said longitudinal strip in upward and downward direction at least substantially perpendicular to the windscreen to be wiped.

Preferably, when mounting the connecting device, the wiper blade is stressed in longitudinal direction away from the connecting device to be wiped.

It is noted that in the invention use is made of a mounting head fixed for rotation to a shaft, wherein said shaft is rotatable alternately in a clockwise and in a counter-clockwise sense carrying said mounting head into rotation.

Thus, in turn said mounting head draws said connecting device into rotation and thereby moves said wiper blade. In the alternative, said mounting head is fixed for translation to a carriage, wherein said carriage can be translated alternately in a one linear direction and in another counter linear direction carrying said mounting head into translation. The present invention can therefore be used for circular or linear movement of said mounting head.

The invention will now be explained more in detail with reference to figures illustrated in a drawing, wherein

- 5 - figure 1 is a perspective, schematic view of a preferred embodiment of a windscreen wiper device according to the invention, with a joint part;
- figures 2 through 4 are several perspective, schematic views of a connecting device, as used in a windscreen wiper device of figure 1;
- 10 - figure 5 shows in detail a schematic view from below of the connecting device of figure 2, further elucidating the working principle of the mutual fixation of the wiper blade and the longitudinal strip at the location of the connecting device of figure 2 according the
15 invention;
- figure 6 is a cross-sectional view of the windscreen wiper device of figure 1 along the line A-A in figure 1;
- figure 7 is a schematic, perspective view of a pin, as
20 used in fixating the wiper blade and the longitudinal strip at the location of the connecting device of figure 3;
- figure 8 shows in detail a schematic side view of a disassembled wiper blade, as used in figure 1; and
- 25 - figures 9 through 11 correspond to figure 5, but relate to other embodiments of the mutual fixation of the wiper blade and the longitudinal strip at the location of the connecting device.

30 Figures 1 shows a preferred variant of a windscreen wiper device 1 according to the invention. Said windscreen wiper device 1 is built up of an elastomeric wiper blade 2 comprising a central longitudinal groove 3, wherein a

longitudinal strip 4 made of spring band steel is fitted in said longitudinal groove 3 (see figures 5, 6 and 7). Said strip 4 forms a flexible carrier element for the rubber wiper blade 2, as it were, which is thus biased in a curved position (the curvature in operative position being that of a windscreen to be wiped). The windscreen wiper device 1 is furthermore built up of a connecting device 5 of metal or plastic for connecting an oscillating wiper arm thereto, with the interposition of a joint part 6. The oscillating wiper arm is pivotally connected to the connecting device 5 about a pivot axis near one end. The preferred embodiment of figure 1 according to the invention comprises a spoiler or "air deflector" 7 which is made in one piece with the rubber wiper blade 2 and which extends along the entire length thereof. No end caps are used, but the free ends of the wiper blade are cut at an oblique angle.

Although not shown in figure 1, but fully understood by a skilled person, said oscillating arm is connected to a mounting head fixed for rotation to a shaft driven by a small motor. In use, the shaft rotates alternately in a clockwise and in a counter-clockwise sense carrying the mounting head into rotation also, which in turn draws said oscillating arm into rotation and by means of said connecting device 5 moves said wiper blade 2.

Figures 2 through 4 show in perspective several views of a connecting device 5 used in the windscreen wiper device 1 of figure 1. As mentioned earlier, this connecting device 5 has a more or less U-shaped cross-section with legs 8. Free ends 9 of said legs 8 of said U-shaped cross-section extend inwardly so as to form grooves or slits 10 for receiving longitudinal sides 11 of said wiper blade 2. Said free ends

9 and parallel walls 12 of said connecting device 5 are provided with holes 13 for receiving one pin 14 of the first type and two pairs of opposite pins 15 of the second type, as will be further explained hereunder. Said connecting device 5 further comprises an interior space 16 functioning as a water channel extending in longitudinal direction of said connecting device 5. During use said water channel 16 transports rain water therethrough. In other words, in use rain water is carried away from a first side of said connecting device 5 facing away from said free end of said oscillating arm to a second side of said connecting device 5 facing towards said free end of said oscillating arm. As a result of the oscillatory movement of said oscillating arm, in practice an over pressure relative to the environment exists at the location of said first side of said connecting device 5, while an under pressure relative to the environment is present at the location of said second side of said connecting device 5. Due to said over pressure and said under pressure rain water is "automatically" pressed through said water channel.

With reference to figures 1 through 4 said joint part 6 is detachably connected to said connecting device 5 by engaging protrusions 17 of said connecting device 5, at the location of said pivot axis, in co-axial recesses 18 provided in said joint part 6. As shown, said protrusions 17 extend outwards on either side of said connecting device 5. The joint part 6 comprises a resilient tongue 19 extending outwardly, while the oscillating arm has a U-shaped cross-section at the location of its connection to said joint part 6, so that the tongue 19 engages in an identically shaped hole provided in a base of said U-shaped cross-section. The connecting device 5 with the wiper blade 2 is mounted onto the oscillating arm

as follows. The joint part 6 being already clipped onto the connecting device 5 is pivoted relative to the connecting device 5, so that said joint part 6 can be easily slid on a free end of the oscillating arm. During this sliding movement the resilient tongue 19 is initially pushed in against a spring force and then allowed to spring back into said hole in said oscillating arm, thus snapping, that is clipping the resilient tongue 19 into the hole of the oscillating arm. This is a so-called bayonet-connection. The oscillating arm together with the joint part 6 may then be pivoted back in a position parallel to the wiper blade 2 in order to be ready for use. By subsequently pushing in again said resilient tongue 19 against the spring force (as if it were a push button), the connecting device 5 and the joint part 6 together with the wiper blade 2 may be released from the oscillating arm. Dismounting the connecting device 5 with the wiper blade 2 from the oscillating arm is thus realized by sliding the connecting device 5 and the joint part 6 together with the wiper blade 2 in a direction away from the oscillating arm.

Said longitudinal strip 4, as shown in figure 5, is provided along an exterior edge 20 thereof with a recess 21 cooperating with said corresponding pin 14 of the first type. Said recess 21 is made through a stamping operation in order to accurately control the shape of said recess 21. In mounted position said wiper blade 2 is allowed to move in longitudinal direction relative to said longitudinal strip 4 outside the location of the interconnection of said connecting device 6 and said wiper blade 2, whereas the pin 14 of the first type ensures that any such longitudinal movement of said wiper blade 2 inside said connecting device 5 is blocked. The pin 14 of the first type locally deforms

the rubber. The retention of the wiper blade 2 additionally may also be the result of friction between legs 8 or the connecting device 5 and the rubber of the wiper blade 2.

5 Referring to figures 5 and 6, in assembled position, the four pins 15 of the second type exert a controllable, predetermined pressure on the longitudinal strip 4, since they are stamped through the rubber material of the wiper blade 2. Thus, any lateral movement between said
10 longitudinal strip 4 and said wiper blade 2 at the location of their interconnection and between said connecting device 5 and said wiper blade 2 at the location of their interconnection is blocked. In use, during each oscillatory movement of the oscillatory arm, said wiper blade 2 at the
15 location outside said connection device 5 would normally suffer from the so-called "fishtailing phenomenon", wherein said wiper blade 2 on opposite sides of said connecting device 5 vibrates in an uncontrollable manner parallel to a windscreen to be wiped. Obviously, this "fishtailing
20 phenomenon" results in deteriorated wiping properties, with all negative consequences involved, particularly at high speeds. Hence, said longitudinal strip 4 is allowed to exhibit a curvature at the location of the interconnection of said connecting device 5 and said wiper blade 2.
25 Experimental results have shown that the "fishtailing phenomenon" is now avoided according to the invention at least to a large extend.

Said pins 14,15 of the first and of the second type are
30 preferably sharpened in order to cut through the flexible material of said wiper blade 2.

Figure 8 shows a perspective side view of a longitudinal side 11 of the wiper blade 2, without said pins 14,15 of the first type and of the second type, but with holes 13 showing the longitudinal strip 4 and its recess 21 for the one pin 5 of the first type.

Figures 9, 10 and 11 show alternative embodiments compared to the one shown in figure 5, wherein said figures 5, 9, 10 and 11 correspond to claims 9, 10, 11 and 12 respectively. A skilled person would, for example, easily understand that said pins of the first type and of the second type could have a round cross-section (elliptical or circular), a rectangular cross-section, or a square cross-section.

15 The invention is not restricted to the variants shown in the drawing, but it also extends to other preferred embodiments that fall within the scope of the appended claims.

CLAIMS

1. A windscreen wiper device (1) of the flat blade type, particularly for automobiles, comprising an elastic, elongated carrier element, as well as an elongated wiper blade (2) of a flexible material, which can be placed in abutment with a windscreen to be wiped, which wiper blade (2) includes at least one longitudinal groove (3), in which groove (3) at least one longitudinal strip (4) of the carrier element is disposed, which windscreen wiper device (1) comprises a connecting device (5) for an oscillating arm, wherein said oscillating arm can be pivotally connected to said connecting device (5) about a pivot axis near one end thereof, **characterized in that** said connecting device (5) is connected to the flexible material of said wiper blade (2) by at least one pin (14), wherein said pin (14) cooperates with a recess (21) provided along an exterior edge (20) of said longitudinal strip (4) in order to block any movement of said wiper blade (2) in longitudinal direction thereof relative to said longitudinal strip (4) at the location of the interconnection of said connecting device (5) and said wiper blade (2), wherein said pin (14) allows a movement of said longitudinal strip (4) in upward and downward direction at least substantially perpendicular to the windscreen to be wiped.
2. A windscreen wiper device (1) according to claim 1, wherein said connecting device (5) is connected to the flexible material of said wiper blade (2) by said at least one pin (14) being of a first type and at least one pin (15) of a second type, wherein said pin (15) of

the second type is mounted through the flexible material of said wiper blade (2) at the location of the interconnection of said connecting device (5) and said wiper blade (2) in order to block any lateral movement of longitudinal strip (4) at the location of the interconnection of said connecting device (5) and said wiper blade (2), and wherein said pins (14,15) of the first and of the second type allow a movement of said longitudinal strip (4) in upward and downward direction at least substantially perpendicular to the windscreen to be wiped.

3. A windscreen wiper device (1) according to claim 1 or 2, wherein said pin (14) of the first type allows movement of said wiper blade (2) in longitudinal direction thereof relative to said longitudinal strip (4) outside the location of the interconnection of said connecting device (5) and said wiper blade (2).
4. A windscreen wiper device (1) according to claim 1, 2 or 3, wherein said pins (14,15) of the first and of the second type are stamped through the flexible material of said wiper blade (2).
5. A windscreen wiper device (1) according to claim 2, 3 or 4, wherein said pin (15) of the second type exerts a transverse force on said longitudinal strip (4) in order to block any lateral movement of longitudinal strip (4) at the location of the interconnection of said connecting device (5) and said wiper blade (2).
6. A windscreen wiper device (1) according to claim any of the preceding claims 1 through 5, wherein said pin (14)

of the first type and said pin (15) of the second type are separate constructional elements extending at least substantially perpendicular to the windscreen to be wiped.

5

7. A windscreen wiper device (1) according to any of the preceding claims 1 through 6, wherein said pins (14,15) of the first and of the second type are sharpened in order to cut through the flexible material of said wiper blade (2).

10

8. A windscreen wiper device (1) according to any of the preceding claims 1 through 7, wherein said connecting device (5) has a substantially U-shaped cross-section, wherein free ends (9) of legs (8) of said U-shaped cross-section extend inwardly so as to form grooves (10) for receiving longitudinal sides (11) of said wiper blade (2), and wherein said free ends (9) are provided with holes (13) for receiving said pins (14,15) of the first type and of the second type.

15

20

9. A windscreen wiper device (1) according to any of the preceding claims 1 through 8, wherein said connecting device (5) is connected to the flexible material of said wiper blade (2) by one pin (14) of the first type interconnecting said connecting device (5) and said wiper blade (2) near the middle longitudinal plane of said connecting device (6) perpendicular to the windscreen to be wiped and by two pairs of opposite pins (15) of the second type interconnecting said connecting device (5) and said wiper blade (2) near the outer ends of said connecting device (5).

25

30

10. A windscreen wiper device (1) according to any of the preceding claims 1 through 8, wherein said connecting device (5) is connected to the flexible material of said wiper blade (2) by one pair of opposite pins (14) of the first type interconnecting said connecting device (5) and said wiper blade (2) near the middle longitudinal plane of said connecting device (6) perpendicular to the windscreen to be wiped and by two pairs of opposite pins (15) of the second type interconnecting said connecting device (5) and said wiper blade (2) near the outer ends of said connecting device (5).
11. A windscreen wiper device (1) according to any of the preceding claims 1 through 8, wherein said connecting device (5) is connected to the flexible material of said wiper blade (2) by one pair of opposite pins (14) of the first type and by one pair of opposite pins (15) of the second type interconnecting said connecting device (5) and said wiper blade (2) near the outer ends of said connecting device (5).
12. A windscreen wiper device (1) according to any of the preceding claims 1 through 8, wherein said connecting device (5) is connected to the flexible material of said wiper blade (2) by two pairs of opposite pins (14) of the first type interconnecting said connecting device (5) and said wiper blade (2) near the outer ends of said connecting device (5).
13. A windscreen wiper device (1) according to any of the preceding claims 1 through 12, wherein said connecting

device (5) is pivotally connected to said oscillating arm with the interposition of a joint part (6), and wherein said joint part (6) is detachably connected to said connecting device (5) by engaging protrusions (17) of said connecting device (5), at the location of said pivot axis, in recesses (18) provided in said joint part (6).

14. A windscreen wiper device (1) according to claim 13, wherein said joint part (6) has an at least substantially U-shaped cross-section at the location of its connection to said connecting device (5), and wherein said joint part (6) is provided with a recess (18) provided coaxially with said pivot axis.
15. A windscreen wiper device (1) according to claim 13 or 14, wherein the protrusions (17) extend outwards on either side of said connecting device (5).
16. A windscreen wiper device (1) according to claim 13, 14 or 15, wherein said protrusions (17) are provided with co-axial through holes.
17. A windscreen wiper device (1) according to 13, 14 or 15, wherein said joint part (8) comprises at least one resilient tongue (19) engaging in a correspondingly shaped hole provided in a base of a U-shaped cross-section of said oscillating arm, and wherein said resilient tongue (19) is rotatable along a hinge axis between an outward position retaining said wiper blade (2) onto said oscillating arm and an inward position releasing said wiper blade (2) from said oscillating arm.

18. Method for manufacturing a windscreen wiper device (1) of the flat blade type, particularly for automobiles, comprising an elastic, elongated carrier element, as well as an elongated wiper blade (2) of a flexible material, which can be placed in abutment with a windscreen to be wiped, which wiper blade (2) includes at least one longitudinal groove (3), in which groove (3) at least one longitudinal strip (4) of the carrier element is disposed, which windscreen wiper device (1) comprises a connecting device (5) for an oscillating arm, wherein said oscillating arm can be pivotally connected to said connecting device (5) about a pivot axis near one end thereof, **characterized in that** first a recess (21) is cut along an exterior edge (20) of said longitudinal strip (4), wherein said connecting device (5) is subsequently mounted onto said wiper blade (2), wherein said longitudinal strip (4) is subsequently inserted inside said groove (3), whereinafter at least one pin (14) of the first type and at least one pin (15) of the second type are used, wherein
- first said pin (15) of the second type is used, said pin (15) of the second type being mounted through the flexible material of said wiper blade (2) at the location of the interconnection of said connecting device (5) and said wiper blade (2) in order to block any lateral movement of longitudinal strip (4) at the location of the interconnection of said connecting device (5) and said wiper blade (2);
 - secondly said pin (14) of the first type is used, said pin (14) of the first type cooperating with said recess (21) provided along said exterior edge (20) of said

- longitudinal strip (4) in order to block any movement of said wiper blade (2) in longitudinal direction thereof relative to said longitudinal strip (4) at the location of the interconnection of said connecting device (5) and said wiper blade (2); and
- 5
- said pins (14,15) of the first and of the second type allow a movement of said longitudinal strip (4) in upward and downward direction at least substantially perpendicular to the windscreen to be wiped.

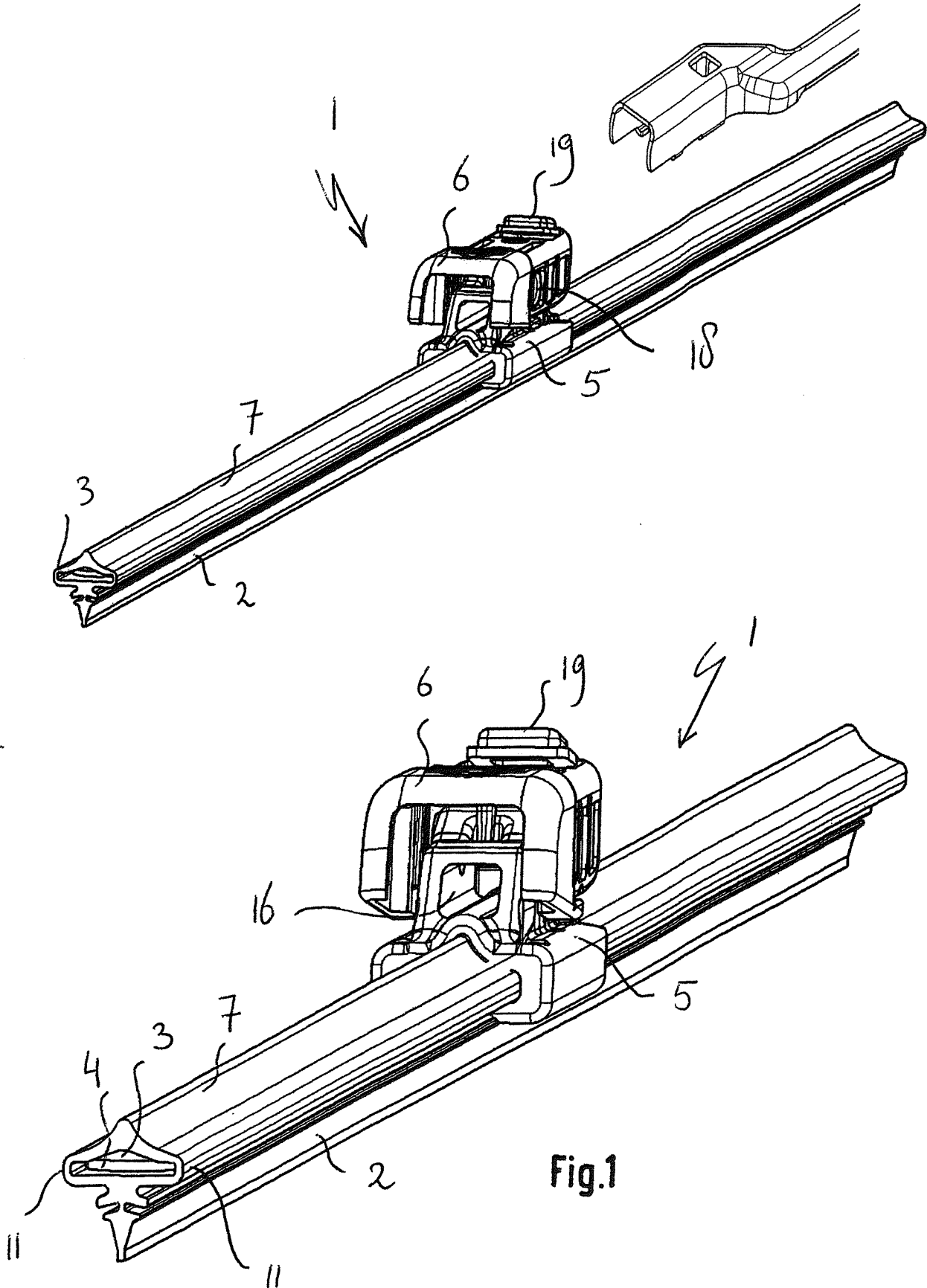

Fig.1

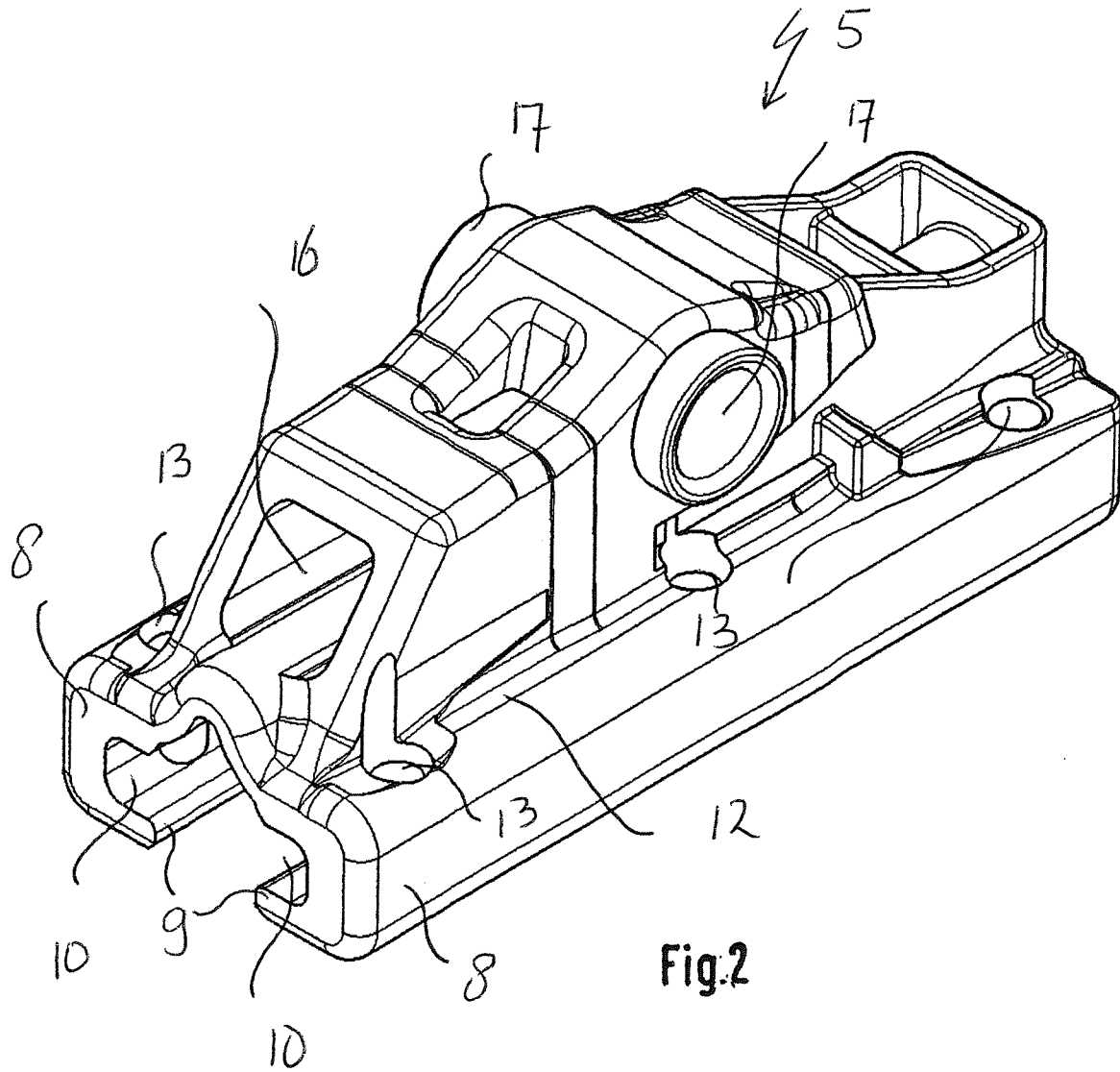

Fig.2

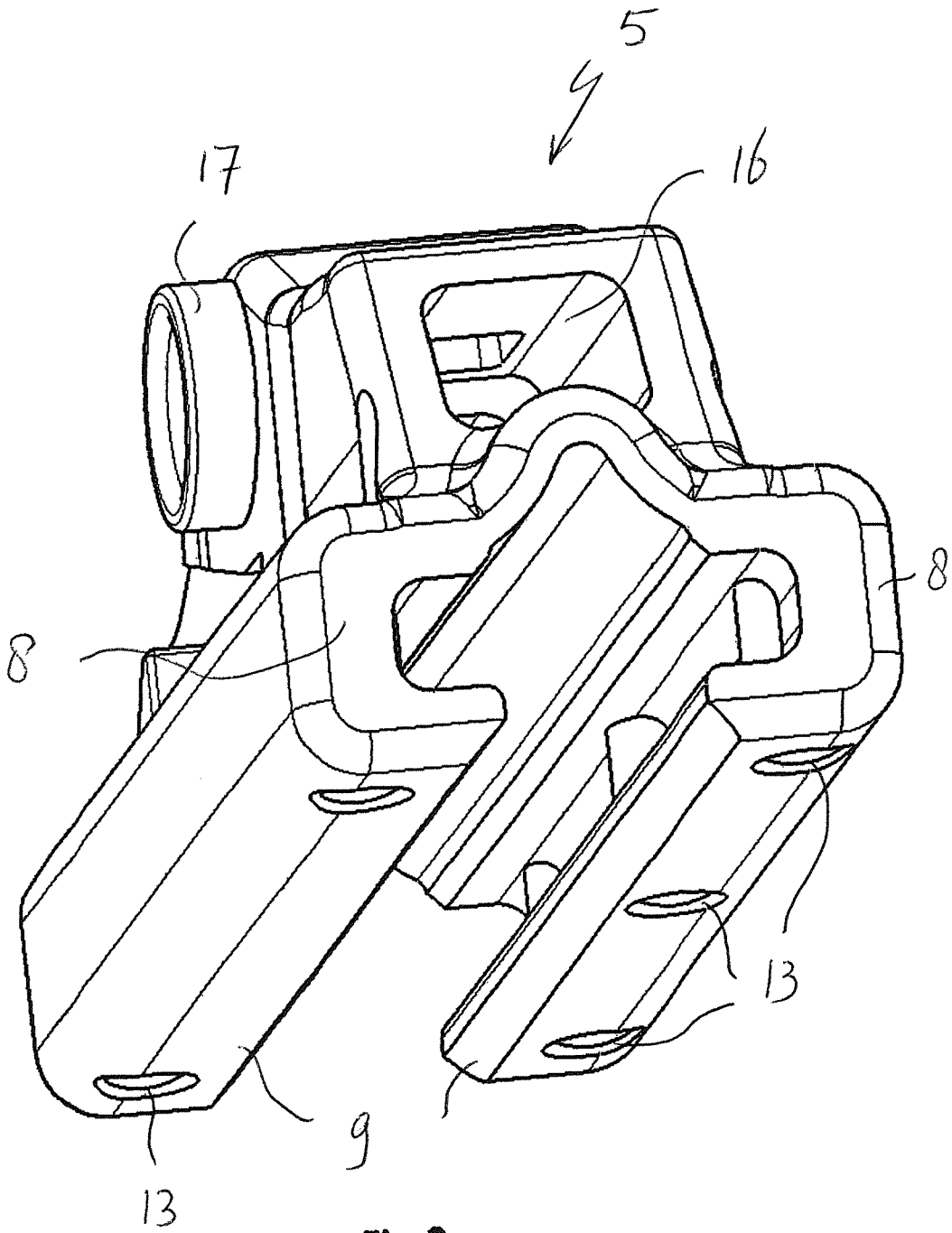

Fig.3

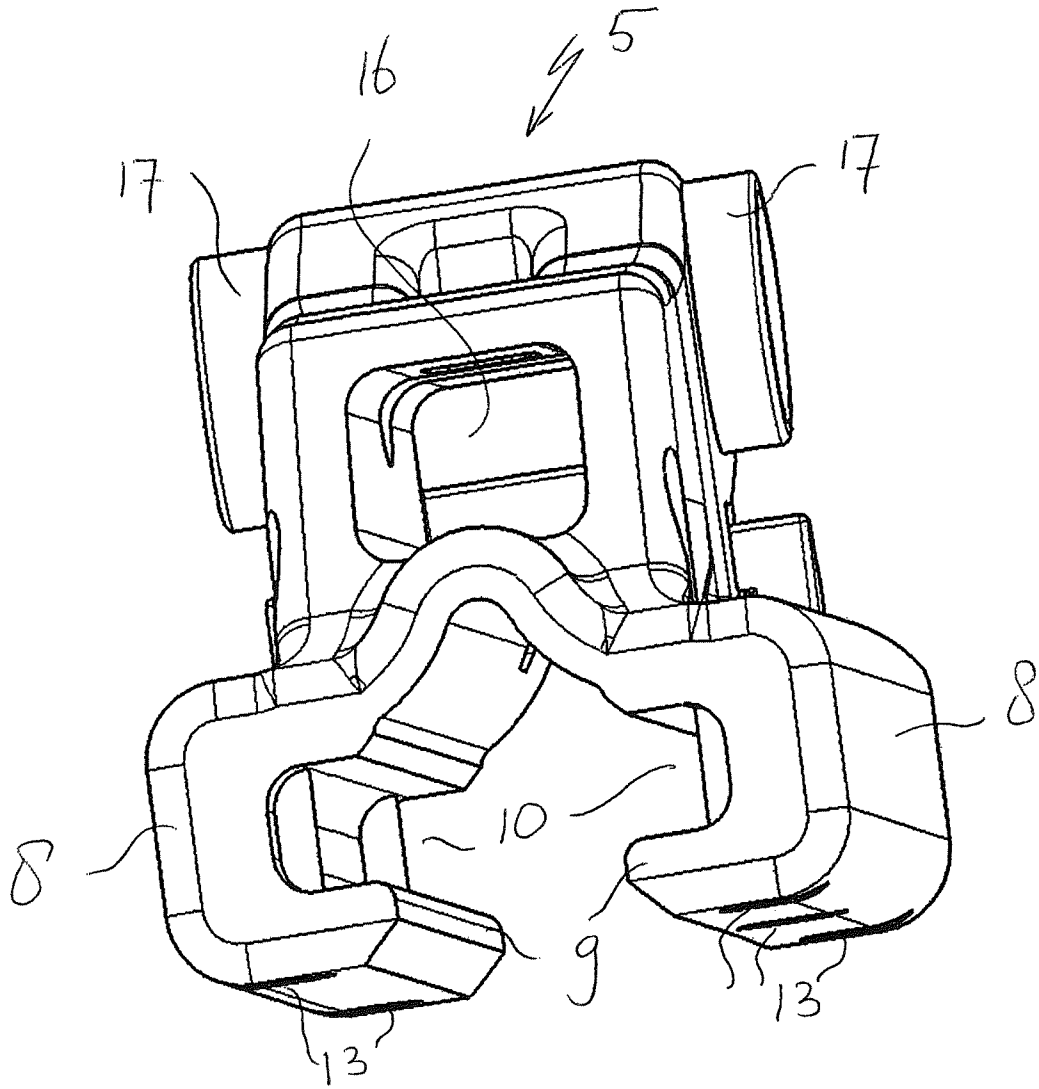

Fig.4

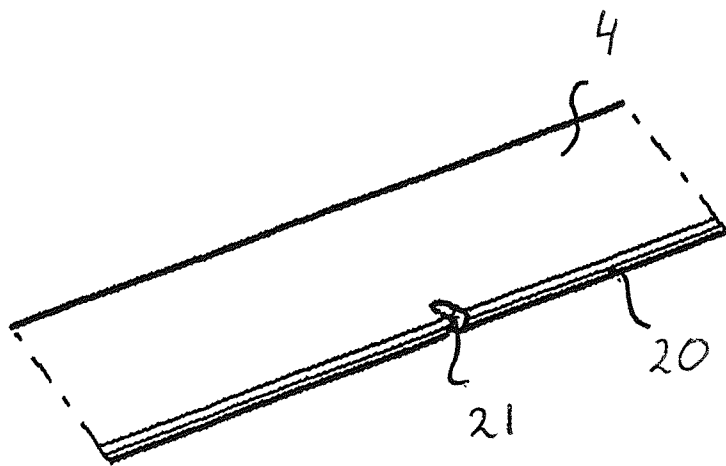
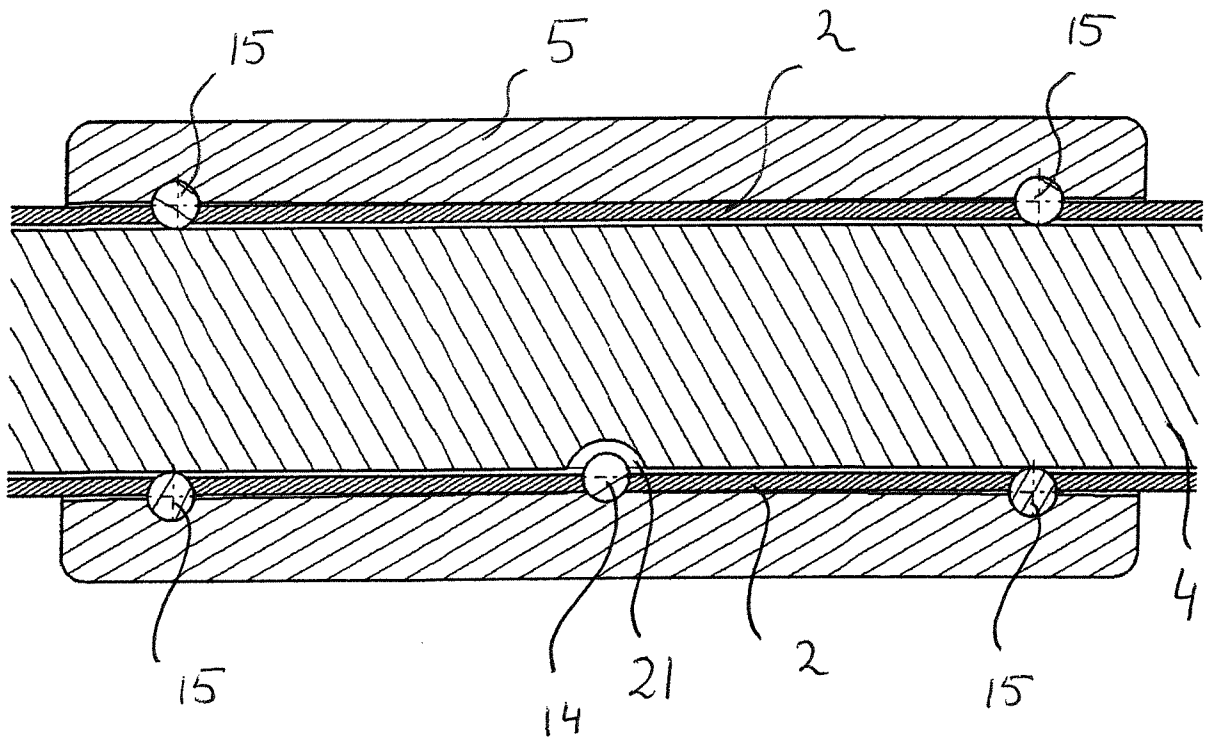

Fig.5

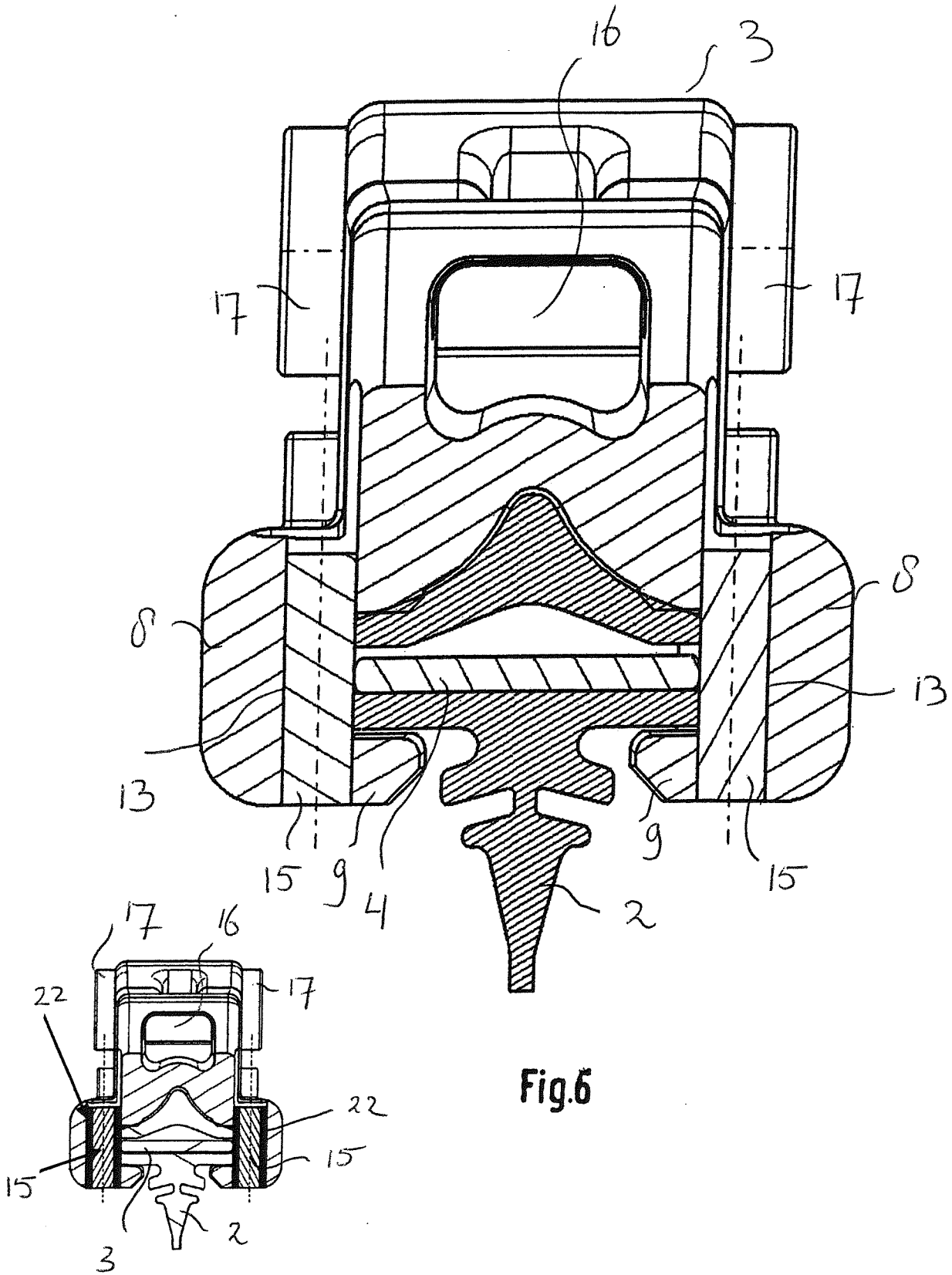

Fig.6

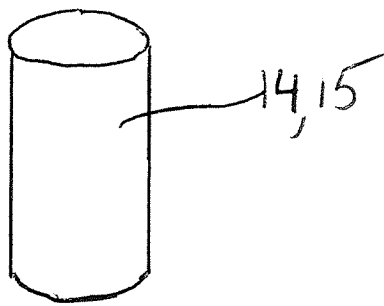

Fig. 7

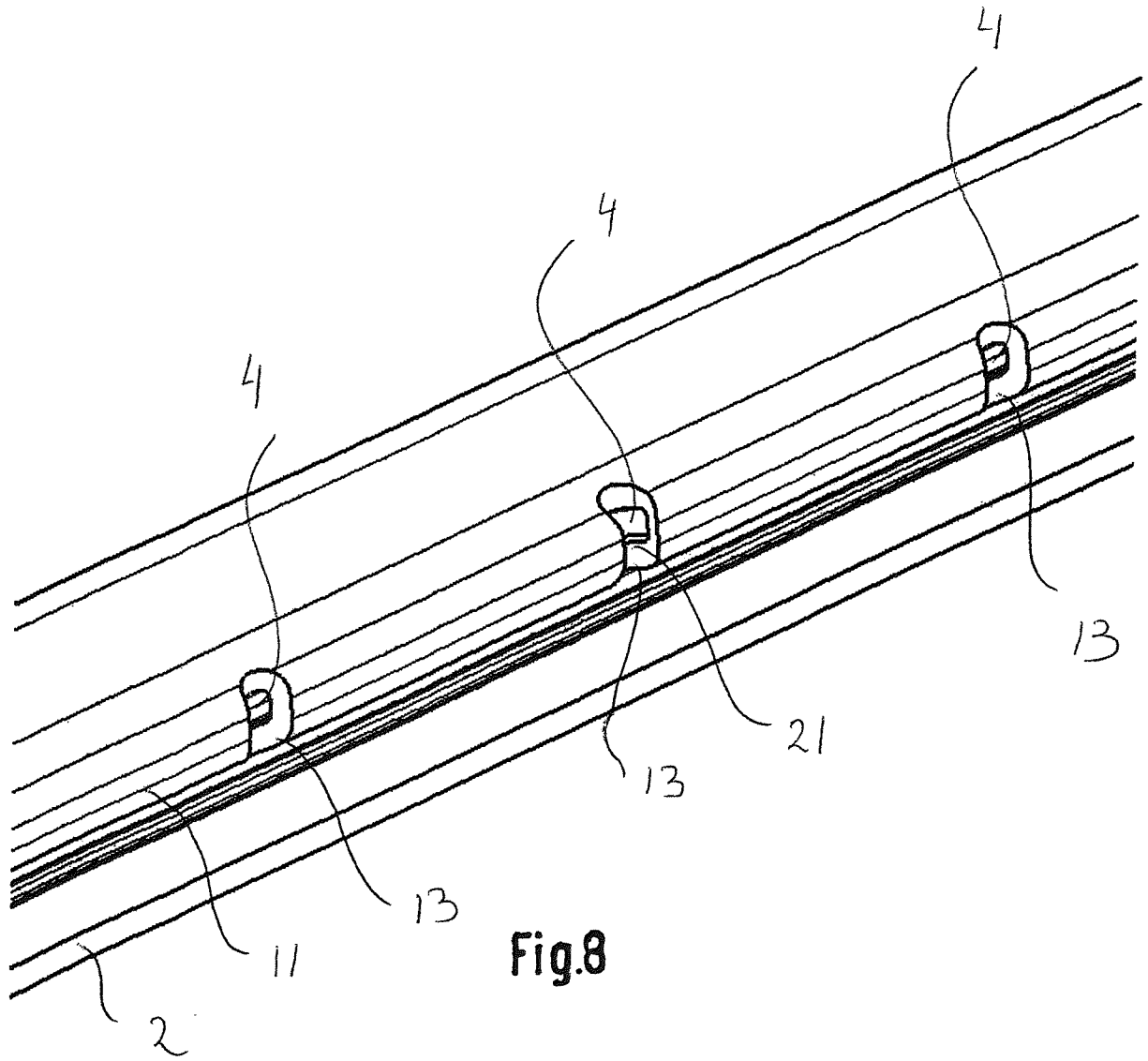

Fig.8

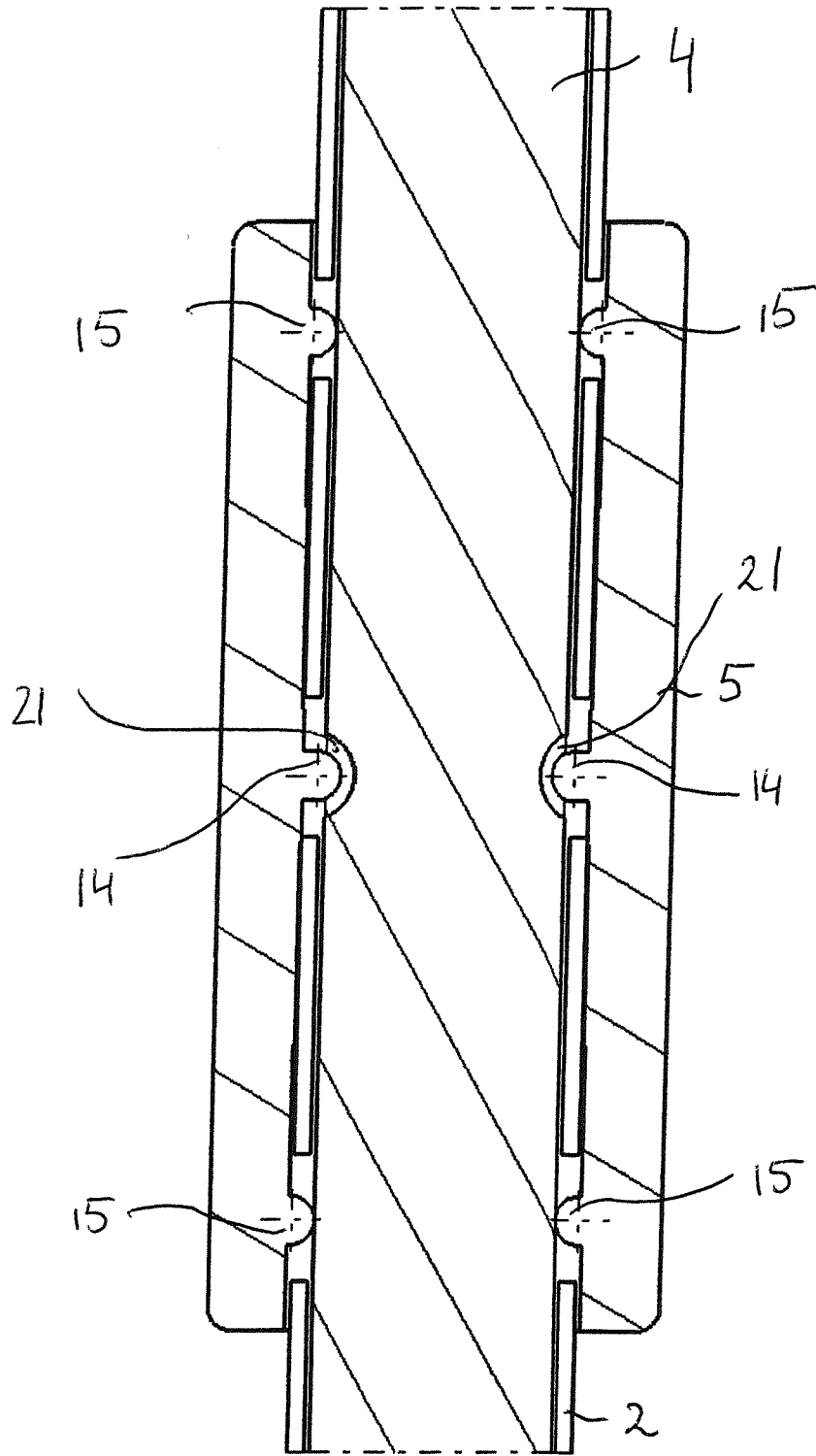

Fig.9

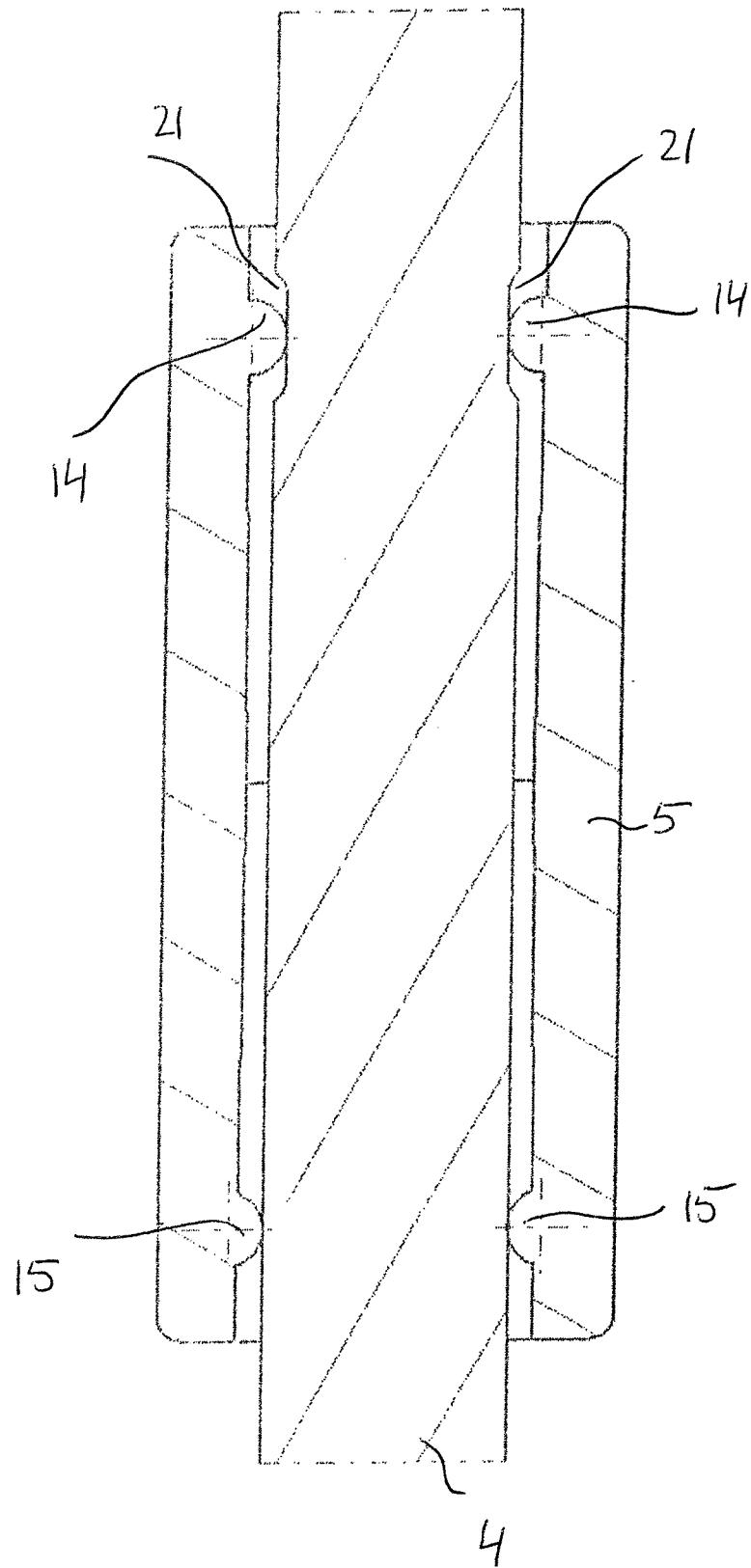

Fig.10

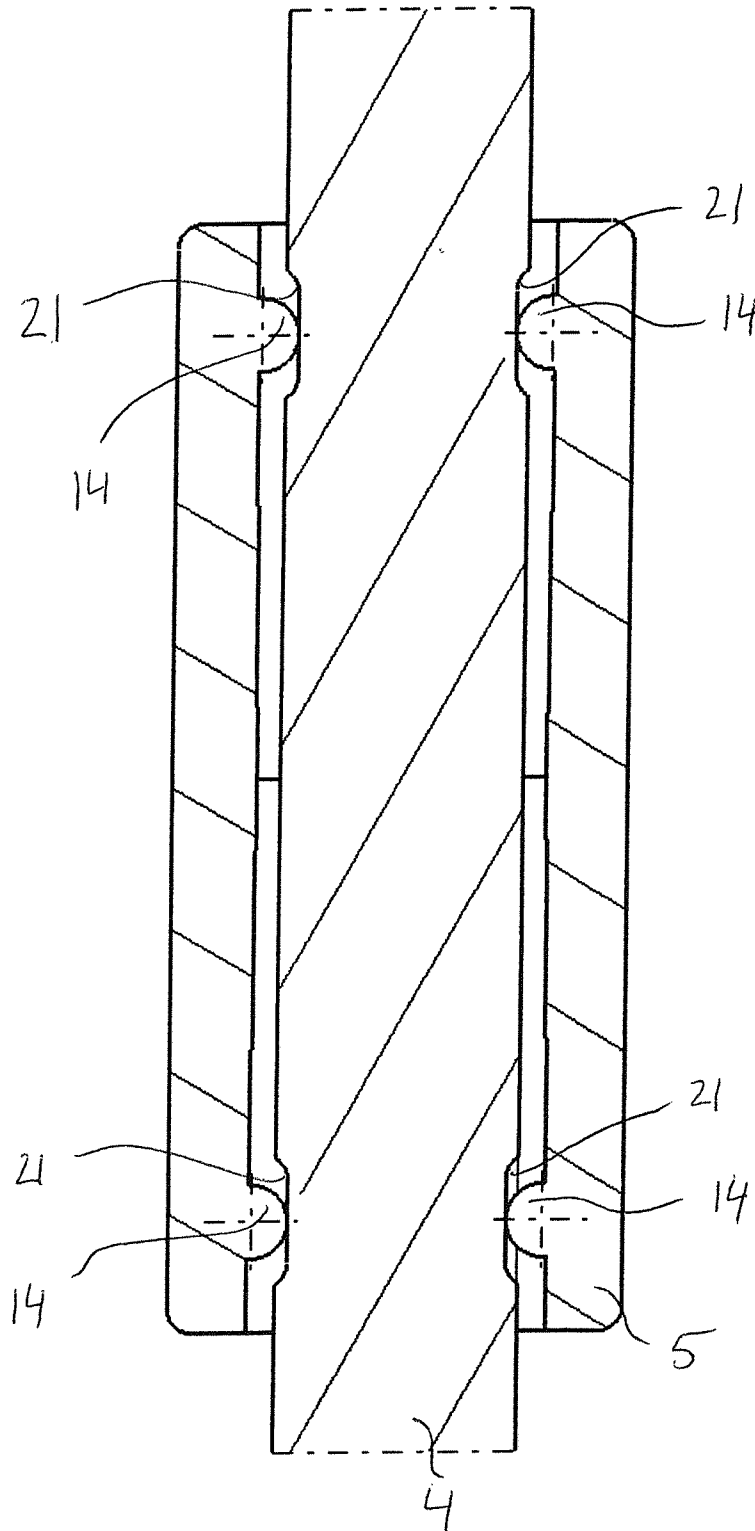

Fig.11

INTERNATIONAL SEARCH REPORT

International application No
PCT/EP2011/055787

A. CLASSIFICATION OF SUBJECT MATTER
INV. B60S1/38
ADD.
According to International Patent Classification (IPC) or to both national classification and IPC

B. FIELDS SEARCHED
Minimum documentation searched (classification system followed by classification symbols)
B60S

Documentation searched other than minimum documentation to the extent that such documents are included in the fields searched

Electronic data base consulted during the international search (name of data base and, where practical, search terms used)
EPO-Internal

C. DOCUMENTS CONSIDERED TO BE RELEVANT

Category*	Citation of document, with indication, where appropriate, of the relevant passages	Relevant to claim No.
X	FR 2 894 544 A1 (VALEO SYSTEMES ESSUYAGE [FR]) 15 June 2007 (2007-06-15) the whole document -----	1-3,5, 9-12,18
X	EP 2 236 366 A1 (FEDERAL MOGUL SA [BE]) 6 October 2010 (2010-10-06) paragraph [0025]; figure 8 -----	1-3, 12-17
X	DE 100 36 115 A1 (VOLKSWAGEN AG [DE]) 2 January 2003 (2003-01-02) paragraphs [0029] - [0030]; figure 5 -----	1,2,5, 12-15,18
X	FR 2 868 376 A1 (VALEO SYSTEMES ESSUYAGE [FR]) 7 October 2005 (2005-10-07) the whole document ----- -/--	1-3,5,7, 12

Further documents are listed in the continuation of Box C.

See patent family annex.

* Special categories of cited documents :

- "A" document defining the general state of the art which is not considered to be of particular relevance
- "E" earlier document but published on or after the international filing date
- "L" document which may throw doubts on priority claim(s) or which is cited to establish the publication date of another citation or other special reason (as specified)
- "O" document referring to an oral disclosure, use, exhibition or other means
- "P" document published prior to the international filing date but later than the priority date claimed

- "T" later document published after the international filing date or priority date and not in conflict with the application but cited to understand the principle or theory underlying the invention
- "X" document of particular relevance; the claimed invention cannot be considered novel or cannot be considered to involve an inventive step when the document is taken alone
- "Y" document of particular relevance; the claimed invention cannot be considered to involve an inventive step when the document is combined with one or more other such documents, such combination being obvious to a person skilled in the art.
- "&" document member of the same patent family

Date of the actual completion of the international search 21 December 2011	Date of mailing of the international search report 29/12/2011
Name and mailing address of the ISA/ European Patent Office, P.B. 5818 Patentlaan 2 NL - 2280 HV Rijswijk Tel. (+31-70) 340-2040, Fax: (+31-70) 340-3016	Authorized officer Blandin, Béatrice

INTERNATIONAL SEARCH REPORT

International application No
PCT/EP2011/055787

C(Continuation). DOCUMENTS CONSIDERED TO BE RELEVANT		
Category*	Citation of document, with indication, where appropriate, of the relevant passages	Relevant to claim No.
X	DE 100 58 208 A1 (VALEO AUTO ELECTRIC GMBH [DE]) 11 July 2002 (2002-07-11)	1-4,9
A	paragraphs [0058] - [0060]; figures 3-6 -----	6,7
X	WO 2010/016000 A1 (TEKLAS KAUCUK SANAYI VE TICARE [TR]; BICICI BANU [TR]; BOZKURLU MURAT) 11 February 2010 (2010-02-11)	1,3
A	paragraphs [0040] - [0043]; figures 5,6,7 -----	6,8
X	DE 202 20 355 U1 (BOSCH GMBH ROBERT [DE]) 1 April 2004 (2004-04-01)	1,2,4,7, 12
A	page 4, paragraph 25-26; figure 6 -----	6

INTERNATIONAL SEARCH REPORT

Information on patent family members

International application No

PCT/EP2011/055787

Patent document cited in search report	Publication date	Patent family member(s)	Publication date
FR 2894544	A1	15-06-2007	AT 474747 T 15-08-2010
			BR PI0619875 A2 25-10-2011
			CA 2631513 A1 21-06-2007
			CN 101312863 A 26-11-2008
			EP 1968828 A1 17-09-2008
			FR 2894544 A1 15-06-2007
			JP 2009519169 A 14-05-2009
			KR 20080086861 A 26-09-2008
			US 2008263809 A1 30-10-2008
			WO 2007068677 A1 21-06-2007

EP 2236366	A1	06-10-2010	AT 514600 T 15-07-2011
			EP 2236366 A1 06-10-2010
			ES 2369052 T3 24-11-2011
			WO 2010112579 A1 07-10-2010

DE 10036115	A1	02-01-2003	NONE

FR 2868376	A1	07-10-2005	AT 402847 T 15-08-2008
			BR PI0509609 A 18-09-2007
			CA 2561372 A1 17-11-2005
			CN 1950242 A 18-04-2007
			EP 1744940 A1 24-01-2007
			ES 2311977 T3 16-02-2009
			FR 2868376 A1 07-10-2005
			HK 1105928 A1 27-08-2010
			JP 4681603 B2 11-05-2011
			JP 2007531663 A 08-11-2007
			KR 20060133055 A 22-12-2006
			RU 2359850 C2 27-06-2009
			US 2009056049 A1 05-03-2009
			WO 2005108176 A1 17-11-2005

DE 10058208	A1	11-07-2002	DE 10058208 A1 11-07-2002
			WO 0242129 A1 30-05-2002

WO 2010016000	A1	11-02-2010	EP 2349796 A1 03-08-2011
			WO 2010016000 A1 11-02-2010

DE 20220355	U1	01-04-2004	DE 20220355 U1 01-04-2004
			EP 1562804 A1 17-08-2005
			EP 2039571 A1 25-03-2009
			WO 2004045927 A1 03-06-2004
