



(12) **EUROPEAN PATENT APPLICATION**

(43) Date of publication:  
**21.04.2010 Bulletin 2010/16**

(51) Int Cl.:  
**F25D 19/00** <sup>(2006.01)</sup> **F25B 21/02** <sup>(2006.01)</sup>  
**F28D 15/02** <sup>(2006.01)</sup>

(21) Application number: **08167022.6**

(22) Date of filing: **20.10.2008**

(84) Designated Contracting States:  
**AT BE BG CH CY CZ DE DK EE ES FI FR GB GR HR HU IE IS IT LI LT LU LV MC MT NL NO PL PT RO SE SI SK TR**  
 Designated Extension States:  
**AL BA MK RS**

(72) Inventors:  
 • **Krosse, Luciënne Jozefina Wilhelmina Maria**  
**6951 HX Dieren (NL)**  
 • **Linnewiel, Arnold Felix**  
**1411 PZ Naarden-Vesting (NL)**  
 • **Oversloot, Hendrik Pieter**  
**4706 AK Roosendaal (NL)**

(71) Applicants:  
 • **Nederlandse Organisatie voor toegepast-natuurwetenschappelijk onderzoek TNO**  
**2628 VK Delft (NL)**  
 • **Coltratech B.V.**  
**5261 BC Vught (NL)**

(74) Representative: **Hatzmann, Martin et al**  
**Vereenigde Johan de Wittlaan 7**  
**2517 JR Den Haag (NL)**

(54) **Container for storing articles at a predetermined temperature**

(57) Container for storing articles at a predetermined temperature, comprising heat insulated walls (9), as well as a Peltier element (1) which, under control of a control module (2), can be energized by a battery (3) in order to collect or emit heat from/to the inside of the container. The Peltier element is connected, via a heat spreader (4), to one or more heat pipes (5) extending through at least one of said insulating walls (9) which is connected

to outside means for emitting or collecting heat to/from the outside environment of the container, as an outside container frame (6) or a part of such frame and/or a heat conducting foil or coating (7), applied on the outside of at least one of said insulating walls (9). The container, moreover, may comprise photovoltaic means (8) outside the container, arranged for converting light into electric energy which can be fed to said Peltier element.

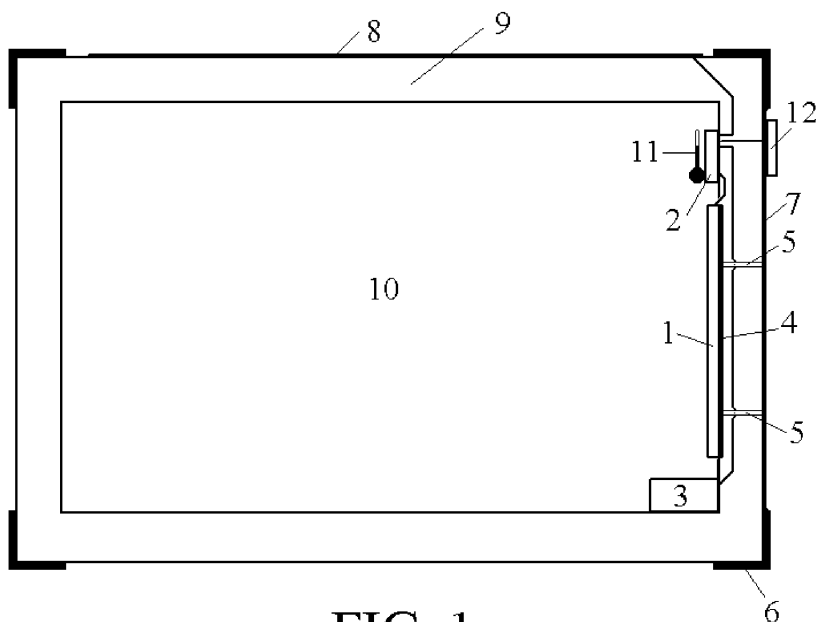

**FIG. 1**

## Description

**[0001]** The transportation sector has a great need for methods and means for the transportation of products in an guaranteed and stable temperature environment. Important conditions for such products are: no increase of mass or volume, self-supporting (i.e. no mains needed), reliable, self regulating and without combustible, toxic or ecotoxic media.

**[0002]** In present cool box configurations no use is made of active refrigeration or heating. The performances are determined by the quality of the isolated walls ( $\lambda \approx 0.0042\text{W/mK}$ ). Alternative cool boxes, e.g. in use in the aviation, may use dry ice.

**[0003]** Both variants have in common that the maximum admissible transportation time is determined by the internal temperature rise in the container. Use is made of a certain buffer of dry ice and/or thermal mass. If the container, during transportation, would have to wait for longer time in the burning sun, the maximum transportation time will be drastically restricted.

**[0004]** Thus, a need exists within the transportation sector for a solution which comprises active cooling, which is self-supporting, reliable, self-regulating, light en small. It is an aim of the present invention to provide this need.

**[0005]** According to the invention it is preferred to provide a container for storing articles at a predetermined temperature, comprising heat insulated walls, the container comprising a Peltier element which, under control of a control module, can be energized by a battery in order to collect or emit heat from/to the inside of the container; the Peltier element being connected, via a heat spreader, to one or more heat pipes extending through at least one of said insulating walls which is connected to outside means for emitting or collecting heat to/from the outside environment of the container.

**[0006]** The outside means may comprise an outside container frame or a part of such frame and/or a heat conducting foil or coating, applied on the outside of at least one of said insulating walls.

**[0007]** Moreover, the container may comprise photovoltaic means outside the container, arranged for converting light into electric energy which can be fed to said Peltier element.

**[0008]** The configuration according to the present will be elucidated hereinafter, referencing to figure 1.

**[0009]** The container for storing articles at a predetermined temperature shown in figure 1, comprises heat insulated walls 9, surrounding the container's inside room 10, which can be filled -via a lid (not shown) with articles to be transported. The container comprises a Peltier element 1 which, under control of a control module 2, connected to a thermometer 11, can be energized by a battery 3 in order to collect or emit heat from/to the inside of the container, depending of the actual and the desired inside temperature and the outside temperature. The Peltier element is connected, via a heat spreader 4, to one

or more heat pipes 5 which extend through at least one of the insulating walls 9 and which are connected to outside means for emitting or collecting heat to/from (again, depending of the actual and the desired inside temperature and the outside temperature) the outside environment of the container.

**[0010]** Container according to claim 1, said outside means for emitting or collecting heat may be formed by an outside container frame 6 or a part of such frame. Instead or additionally, those outside means may comprise a heat conducting foil or coating 7, applied on the outside of at least one of said insulating walls.

**[0011]** The electric power supply of the (self-supporting) container may be supplemented by the electrical output of a photovoltaic layer 8 which is provided outside the container, and which is arranged for converting incident light into electric energy which can be fed, under control of control module 2 to the Peltier element.

**[0012]** Finally, a control/display unit 12 is provided outside the container, which is arranged to switch ON/OFF the circuitry and to set/adjust the container's inside temperature; moreover, unit 12 can display the actual inside temperature, the remaining battery charge, etc.

## Claims

1. Container for storing articles at a predetermined temperature, comprising heat insulated walls, the container comprising a Peltier element (1) which, under control of a control module (2), can be energized by a battery (3) in order to collect or emit heat from/to the inside of the container; the Peltier element being connected, via a heat spreader (4), to one or more heat pipes (5) extending through at least one of said insulating walls which is connected to outside means for emitting or collecting heat to/from the outside environment of the container.
2. Container according to claim 1, said outside means comprising an outside container frame (6) or a part of such frame.
3. Container according to claim 1 or 2, said outside means comprising a heat conducting foil or coating (7), applied on the outside of at least one of said insulating walls.
4. Container according to claim 1, comprising photovoltaic means (8) outside the container, arranged for converting light into electric energy which can be fed to said Peltier element.

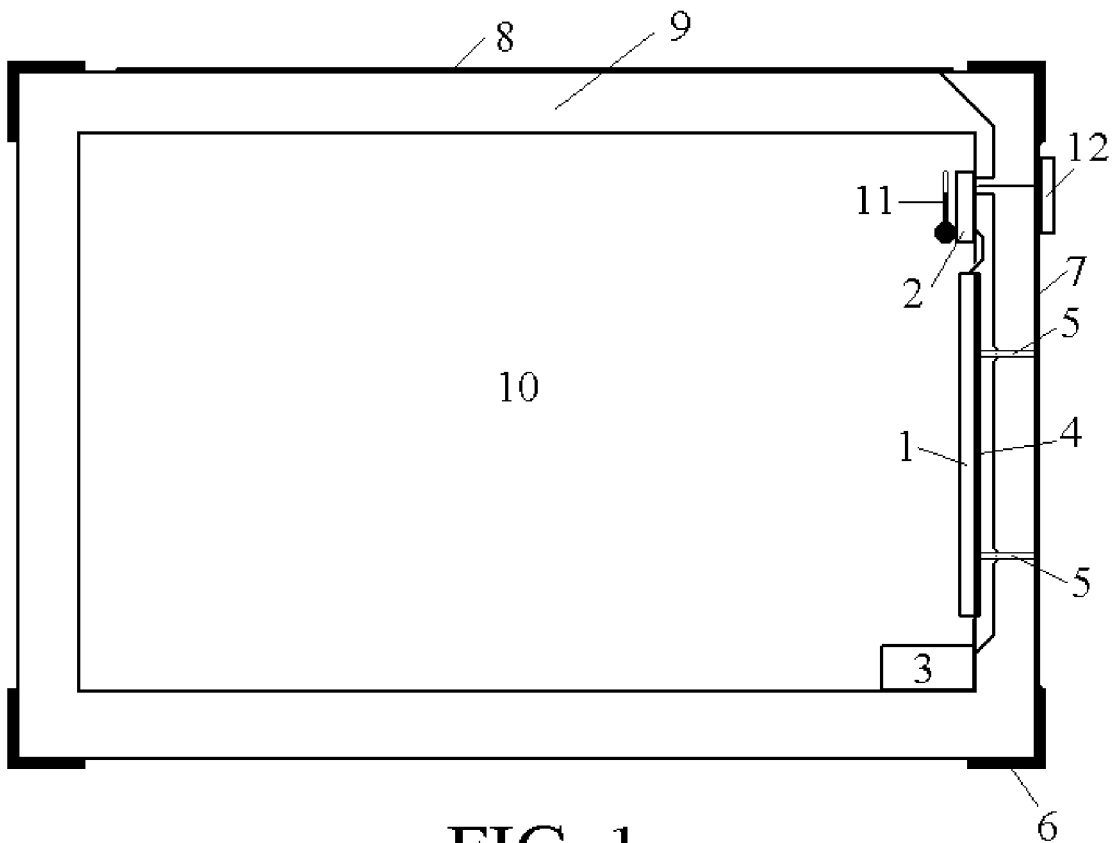

FIG. 1



EUROPEAN SEARCH REPORT

Application Number  
EP 08 16 7022

DOCUMENTS CONSIDERED TO BE RELEVANT			
Category	Citation of document with indication, where appropriate, of relevant passages	Relevant to claim	CLASSIFICATION OF THE APPLICATION (IPC)
X	EP 0 645 593 A (FUJI ELECTRIC CO LTD [JP]) 29 March 1995 (1995-03-29) * columns 2-5; claims 1-4; figures 1,2 * -----	1-4	INV. F25D19/00 F25B21/02 F28D15/02
A	KR 2004 0051119 A (CHO MIN SU) 18 June 2004 (2004-06-18) * pages 2,3; claims 1-3; figure 1 * -----	1	
A	JP 2000 088424 A (MSC TECHNOS KK) 31 March 2000 (2000-03-31) * pages 1-3; claims 1-3; figures 1,2 * -----	1,2	
A	US 4 981 019 A (HICKS CAROLE L [US] ET AL) 1 January 1991 (1991-01-01) * columns 1-4; figures 1-7 * -----	1,2,4	
A	US 2002/104318 A1 (JAAFAR ALI [US] ET AL) 8 August 2002 (2002-08-08) * pages 1,2; figures 1,2 * -----	1,2,4	
The present search report has been drawn up for all claims			TECHNICAL FIELDS SEARCHED (IPC)
			F25B F25D F28D F28F
Place of search		Date of completion of the search	Examiner
Munich		30 January 2009	Amous, Moez
CATEGORY OF CITED DOCUMENTS			
X : particularly relevant if taken alone Y : particularly relevant if combined with another document of the same category A : technological background O : non-written disclosure P : intermediate document T : theory or principle underlying the invention E : earlier patent document, but published on, or after the filing date D : document cited in the application L : document cited for other reasons ..... & : member of the same patent family, corresponding document			

1  
EPO FORM 1503 03.82 (P04C01)

**ANNEX TO THE EUROPEAN SEARCH REPORT  
ON EUROPEAN PATENT APPLICATION NO.**

EP 08 16 7022

This annex lists the patent family members relating to the patent documents cited in the above-mentioned European search report. The members are as contained in the European Patent Office EDP file on The European Patent Office is in no way liable for these particulars which are merely given for the purpose of information.

30-01-2009

Patent document cited in search report		Publication date	Patent family member(s)	Publication date
EP 0645593	A	29-03-1995	DE 69405504 D1	16-10-1997
			DE 69405504 T2	05-02-1998
			JP 7091796 A	04-04-1995
-----				
KR 20040051119	A	18-06-2004	NONE	
-----				
JP 2000088424	A	31-03-2000	NONE	
-----				
US 4981019	A	01-01-1991	NONE	
-----				
US 2002104318	A1	08-08-2002	NONE	
-----				

EPO FORM P0459

For more details about this annex : see Official Journal of the European Patent Office, No. 12/82