

May 16, 1961

G. W. FABEL ET AL
LOUDSPEAKER CONSTRUCTION

2,984,712

Filed Aug. 24, 1959

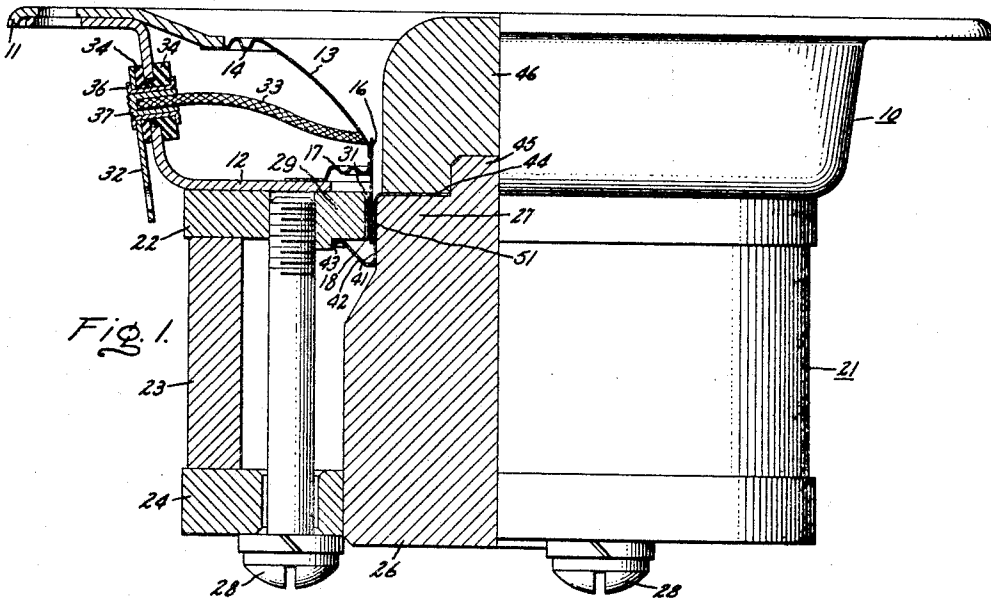

Fig. 1.

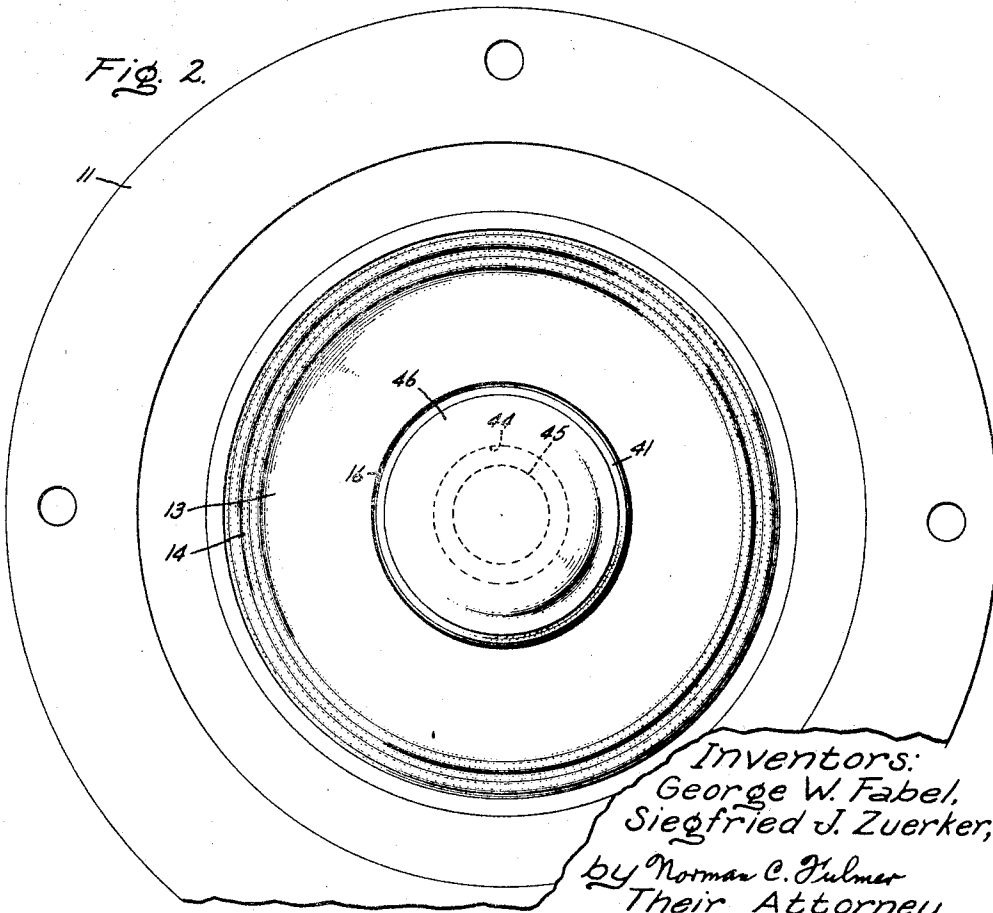

Fig. 2.

Inventors:
George W. Fabel,
Siegfried J. Zuerker,
by Norman C. Hulmer
Their Attorney.

1

2,984,712

LOUDSPEAKER CONSTRUCTION

George W. Fabel, Auburn, and Siegfried J. Zuerker, Utica, N.Y., assignors to General Electric Company, a corporation of New York

Filed Aug. 24, 1959, Ser. No. 835,622

10 Claims. (Cl. 179—115.5)

This invention relates to loudspeakers for producing sound waves in accordance with electrical signals, and more particularly to loudspeakers of the moving coil type wherein a voice coil is positioned in a magnetic field.

A type of loudspeaker that is widely used, and to which the present invention is readily applicable, comprises a diaphragm or cone of generally conical shape, supported at its outer rim by a loudspeaker frame, and having a cylindrically shaped voice coil assembly attached to the cone near the apex thereof. The voice coil includes a winding positioned concentrically with respect to the axis of the cone. A magnet assembly is provided for supplying a magnetic flux radially through the winding of the voice coil. The magnet assembly includes an inner pole piece positioned within the cylindrical voice coil, and an outer pole piece positioned concentrically around the cylindrical voice coil in axial alignment with the inner pole piece.

In designing the construction of a high quality loudspeaker, three important requirements to be considered are: (1) The pole pieces must be properly aligned with respect to each other so as to provide a constant-width annular gap in which the voice coil is positioned; (2) means must be provided for preventing dust and metallic particles from entering into the magnet structure; and (3) a shorted turn should be electrically coupled to the voice coil, to improve the high-frequency response.

An object of the present invention is to provide an improved loudspeaker construction that is simple and economical to manufacture.

Another object is to provide a simple, one-piece element which functions simultaneously as a pole aligning device, a dust seal, and a shorted turn that is coupled to the voice coil winding. Other objects will be apparent from the following description of the invention, and from the claims and the drawing.

In the drawing:

Fig. 1 is a side view, partly in cross-sectional form, of a preferred embodiment of the invention; and

Fig. 2 is a front view of the loudspeaker shown in Fig. 1.

The invention comprises, basically, a cup-shaped element of electrically conductive non-magnetic material positioned over the inner pole piece of a loudspeaker, this cup-shaped element having an outwardly extending flange which curves around the rear end of the voice coil and engages a shoulder of the outer pole piece. In the preferred embodiment of the invention, the cup-shaped element contains an opening in the bottom thereof, through which a nib extends from the inner pole piece, a dome-like element being attached to this nib.

Now referring to the drawing, the preferred embodiment of the loudspeaker construction comprises a frame 10 having a rim 11 at one end thereof and a flange 12 at the other end thereof. A cone or diaphragm 13, which may be made of pressed paper or other suitable material and which has a generally conical shape, is attached to

2

the rim 11 by means of an outer suspension 14 which may comprise a series of concentric folds of the outer edge of the cone 13. A cylindrical voice coil form 16 is attached to the cone 13 near the apex thereof, and is aligned on the axis of the cone 13. The voice coil form 16 may be made from paper or a non-magnetic metal such as aluminum. An inner suspension 17 is attached between the flange 12 and the voice coil form 16, and may be made of impregnated cloth or other suitable material, arranged in concentric folds. A voice coil winding 18 is wound onto, or is otherwise attached to, the form 16, the axis of the winding 18 being aligned with the axis of the form 16 and the cone 13.

A magnet structure 21 comprises a front plate 22 attached to the flange 12, a hollow cylindrical permanent magnet 23 having one end thereof positioned against the rear surface of the front flange 22, a rear plate 24 positioned against the other end of the permanent magnet 23, and a core 26 extending from the rear plate 24, an end of this core being shaped to provide an inner pole piece 27 of circular cross-section and positioned with the confines of the winding 18. Bolts 28 or other suitable means may be used for holding the magnet assembly together.

The front plate 22 is provided with an opening, the part thereof surrounding this opening constituting an outer pole piece 29 which is concentric with, and axially aligned with, the inner pole piece 27. The inner pole piece 27 and the outer pole piece 29 provide an annular gap 31 in which the winding 18 is located, and a fixed magnetic field is provided in this gap, in a radial direction through the winding 18, by the permanent magnet 23 which supplies magnetic flux to the gap via the front plate 22, the rear plate 24, and the core 26, all of which are made from magnetically conductive material such as iron. The ends of the winding 18 are connected to a pair of terminals 32, one of which is shown in the drawing, by means of flexible lead wires 33, one of which is shown in the drawing, the terminals 32 being attached to the frame 10 by means of insulative washers 34 held together by an eyelet 36. The leads 33 are electrically attached to the eyelets 36 by means of solder 37.

In accordance with the present invention, a cup-shaped member 41 is positioned over the inner pole piece 27 and has an annular rim 42 which extends around the lower edge of the voice form 16 and thence outwardly and into engagement with the inner face of an annular shoulder 43 on the rear surface of the front plate 22. Preferably, the outer edge of the rim 42 is curved, as shown, so that it readily engages both the shoulder 43 and rear surface of the front plate 22. The rim 42 is spaced from the lower edge of the voice coil form 16 by an amount sufficient to prevent the form 16 from contacting the rim 42 during operation of the loudspeaker. An opening 44 is provided at the center of the cup-shaped member 41, and a nib 45 extends from the inner pole 27 through the opening 44. A dome-shaped member 46 is attached to the nib 45 and engages against the surface of the cup-shaped member 41 thereby aiding in holding it in place. The cup-shaped member 41 is also held in place by its engagement with the top and side of the inner pole piece 27 and by the engagement of the rim 42 with the shoulder 43 and the rear surface of the front plate 22. The cup-shaped member 41 is made from electrically conductive non-magnetic material, such as copper or aluminum, and is symmetrical and concentric with respect to the axis of the cone 13 and voice coil winding 18.

The loudspeaker functions as follows: The output of an audio amplifier or other signal source is connected to the terminals 32, whereupon an audio signal is applied to the winding 18, and the current thereby applied in the

winding 18 reacts with the magnetic field in the gap 31 in a manner causing the voice coil form 16, and hence the cone 13, to vibrate axially in accordance with the electrical signals, thereby producing sound signals.

The cup-shaped member 41 performs three functions simultaneously, as has been mentioned above. The member 41 functions as an accurate spacer or jig, between the inner and outer poles 27 and 29, due to the engagement of the cylindrical side portion 51 thereof with the outer surface of the inner pole 27 and the engagement of the outer edge of the rim thereof with the shoulder 43 on the outer pole 29. The cup-shaped member 41 functions as a dust seal between the gap 31 and the inner part of the magnet structure 21, due to its aforesaid engagement with the inner and outer pole pieces near the gap 31. The cylindrical side 51 of the cup-shaped member 41 functions as a shorted turn that is inductively coupled to the winding 18. This improves the high-frequency response of the loudspeaker as is well-known, because at the higher frequencies a relatively greater amount of current is induced from the winding 18 into the shorted turn 51, whereby the impedance of the winding 18 is prevented from rising at the higher frequencies. Such a rise in the impedance of the winding 18 at higher frequencies, if allowed to occur, would result in a lower amount of signal current flowing in the winding 18, and this would, of course, cause reduced sound output from the diaphragm 13 at the higher frequencies.

The dome-shaped member 46 functions to fill in the space that would otherwise be present in front of the voice coil assembly 16, 18 and prevents the sound waves from the cone 13 from resonating, and from causing acoustical perturbances, in this space. The outer corners of the dome member 46 are rounded, as shown, to reduce refraction of the acoustical waves. The action of the member 46 can be explained in the following manner: The air gap on both sides of the voice coil at the region of the magnetic poles 27 and 29 constitutes an acoustic coupling between both sides of the cone, this acoustic coupling being provided by the air path down along the inside of the voice coil, around the rear edge thereof, and up along the outside thereof. If the member 46 is omitted, a resonant condition within the frequency range of the loudspeaker exists between the two cone surfaces which increases the volume flow through the air gap, thus lowering the radiation pressure at the radiating surface of the cone. In addition, the relatively large surface of the front of the cone core 26 reflects an appreciable amount of acoustic energy which will, if the acoustic path lengths are such that the reflected energy is out of phase with the radiated energy, cancel some of the radiated energy, cancel some of the radiated energy. Both effects, the shorting effect of the air gap and the reflection, occur together and result in a marked decrease of radiation. When the dome-shaped member 46 is added, the shorting air path is lengthened, its resistance is increased, and the resonant condition is made to occur at a frequency outside the range of the loudspeaker. The member 46 also functions to prevent reflection of acoustic energy from the front of the core 26.

While dust seals, centering devices, and shorted rings have been known and used in loudspeaker constructions, and their virtues have been well recognized, it has heretofore been awkward or impossible, and relatively cumbersome and expensive, to utilize all three of these desirable devices simultaneously in a loudspeaker construction. The present invention provides a novel and practical solution to the long-standing need for a loudspeaker construction in which the desirable features of a centering device, a dust seal, and a shorted ring are simultaneously employed.

While a preferred embodiment of the invention has been shown and described, various other embodiments and modifications thereof will be apparent to those skilled

in the art, and will fall within the scope of the present invention as defined in the following claims.

What we claim as new and desire to secure by Letters Patent of the United States is:

1. A loudspeaker construction comprising an inner pole piece, an outer pole piece arranged concentrically with said inner pole piece thereby providing a radial gap between said pole pieces, means for providing magnetic flux radially in said gap, a cylindrical voice coil positioned in said gap for axial movement therein, a diaphragm coupled to said voice coil, and a cup-shaped member of electrically conductive non-magnetic material positioned over said inner pole piece and having a cylindrical portion thereof adjacent to the inner surface of said voice coil, said member being provided with an outwardly extending rim shaped to extend around an end of said voice coil and into radially fixed engagement with said outer pole piece, said rim being continuous and unbroken whereby said cup-shaped member functions simultaneously as a dust seal, as a pole centering device, and as a shorted turn for said voice coil.

2. A loudspeaker construction comprising an inner pole piece, an outer pole piece arranged coaxially with respect to said inner pole piece thereby providing a radial gap between said pole pieces, means for providing magnetic flux in said gap, a cylindrical voice coil positioned in said gap for axial movement therein, a diaphragm coupled to said voice coil, and a member of electrically conductive non-magnetic material arranged to surround said inner pole piece and having a rim extending outwardly and around an end of said voice coil and into radially fixed engagement with said outer pole piece, said member having a cylindrical portion thereof positioned adjacent to a surface of said cylindrical voice coil.

3. A loudspeaker construction comprising an inner pole piece, an outer pole piece arranged coaxially with respect to said inner pole piece thereby providing a radial gap between said pole pieces, said outer pole piece being provided with an annular shoulder, means for providing magnetic flux radially in said gap, a cylindrical voice coil positioned in said gap for axial movement therein, a diaphragm coupled to said voice coil, and a member of electrically conductive non-magnetic material arranged to surround said inner pole piece and having rim extending outwardly and around an end of said voice coil and into engagement with said annular shoulder, said member having a cylindrical portion thereof positioned adjacent to a surface of said cylindrical voice coil.

4. A loudspeaker construction comprising an inner pole piece, an outer pole piece arranged coaxially with respect to said inner pole piece, thereby providing a radial gap between said pole pieces, means for providing magnetic flux radially in said gap, a cylindrical voice coil positioned in said gap for axial movement therein, a diaphragm coupled to said voice coil, a member of electrically conductive non-magnetic material arranged to surround said inner pole piece and having a cylindrical portion thereof adjacent to the inner surface of said voice coil, said member being provided with a rim extending outwardly and around an end of said voice coil and into engagement with said outer pole piece, and a dome positioned on said inner pole piece and extending beyond the other end of said voice coil.

5. A loudspeaker construction comprising an inner pole piece, an outer pole piece arranged coaxially with respect to said inner pole piece thereby providing a radial gap between said pole pieces, a permanent magnet arranged between said inner and outer pole pieces in a magnetic circuit externally of said gap for providing magnetic flux radially in said gap, a cylindrical voice coil positioned in said gap for axial movement therein, a cone-shaped diaphragm attached near the apex thereof to said voice coil at an end thereof, and a member of electrically conductive non-magnetic material arranged to surround said inner pole piece and having a cylindrical portion thereof

5

adjacent to the inner surface of said voice coil, said member being provided with a rim extending outwardly and around the other end of said voice coil and into radially fixed engagement with said outer pole piece.

6. A loudspeaker construction comprising an inner pole piece, an outer pole piece arranged coaxially with respect to said inner pole piece thereby providing a radial gap between said pole pieces, a cylindrical voice coil positioned in said gap for axial movement therein, a permanent magnet arranged in a magnetic circuit between said inner and outer pole pieces externally of said gap for providing magnetic flux radially in said gap, a cup-shaped member of electrically conductive non-magnetic material positioned over said inner pole piece and having a cylindrical portion thereof adjacent to the inner surface of said voice coil, said member being provided with an outwardly extending rim shaped to extend around an end of said voice coil and into engagement with said outer pole piece, said cup-shaped member containing an opening through the bottom thereof, said inner pole piece being provided with a nib extending through said opening, and a dome attached to said nib and extending beyond the other end of said voice coil.

7. A loudspeaker construction comprising a first plate of magnetic material and containing an opening therethrough, a permanent magnet of hollow cylindrical shape positioned with an end thereof against the rear surface of said first plate, a second plate arranged against the other end of said permanent magnet, a core of magnetic material extending from said second plate and into said opening of said first plate thereby providing a radial gap containing radially oriented magnetic flux between said core and said first plate, a cylindrical voice coil positioned in said gap for axial movement therein, and a member of electrically conductive non-magnetic material arranged to surround said core at said gap and having a cylindrical portion thereof adjacent to the inner surface of said voice coil, said member being provided with a rim extending around an end of said voice coil and into radially fixed engagement with said first plate.

8. A loudspeaker construction comprising a frame, a magnet structure attached to said frame and comprising a first plate of magnetic material attached to said frame and containing a circular opening aligned upon an axis of said frame, a permanent magnet of hollow cylindrical shape having an end thereof positioned against the rear surface of said first plate, a second plate of magnetic material positioned against the other end of said permanent magnet, a core of magnetic material extending from said second plate and into said opening of the first plate thereby providing a radial gap containing radially oriented magnetic flux, a diaphragm of conical shape arranged to be supported by said frame and aligned upon said axis, a cylindrical voice coil positioned in said gap for axial movement therein and attached at an end thereof to said diaphragm near the apex thereof, and a member

6

of electrically conductive non-magnetic material arranged to surround said inner pole piece and having a cylindrical portion thereof adjacent to the inner surface of said voice coil, said member being provided with a rim extending outwardly and around the other end of said voice coil and into radially fixed engagement with the inner surface of said first plate.

9. A loudspeaker construction comprising a first plate of magnetically conductive material and having an opening therethrough, said first plate being provided with an annular shoulder concentric with said opening on one side thereof, a core member of magnetically conductive material positioned to extend within said opening thereby providing a radial gap, a magnet connected in a magnetic circuit between said core and said first plate for providing magnetic flux radially in said gap, a cylindrical voice coil positioned in said gap for axial movement therein, and a member of electrically conductive non-magnetic material arranged to surround said core at said gap and having a cylindrical portion thereof adjacent to the inner surface of said voice coil, said member being provided with a rim extending outwardly and around an end of said voice coil and into engagement with said shoulder.

10. A loudspeaker construction comprising a frame, a magnet structure having a first plate containing an opening and attached to said frame, a core of magnetic material positioned to extend within said opening thereby providing a radial gap between said core and said first plate, a magnet arranged in a magnetic circuit between said core and said first plate for providing magnetic flux radially in said gap, said first plate being provided with an annular shoulder on the side thereof away from said frame, a cylindrical voice coil positioned in said gap for axial movement therein, a diaphragm of conical shape arranged to be supported by said frame and attached near the apex thereof to an end of said voice coil, a cup-shaped member of electrically conductive non-magnetic material positioned over the end of said core at said gap and having a cylindrical portion thereof adjacent to the inner surface of said voice coil, said member being provided with an outwardly extending rim extending around the other end of said voice coil and into engagement with said shoulder, said cup-shaped member containing an opening in the bottom thereof at said end of said core, said core being provided with a nib extending through said opening of the cup-shaped member, and a dome attached to said nib and extending beyond said first-mentioned end of said voice coil.

References Cited in the file of this patent

FOREIGN PATENTS

563,209	Canada	Sept. 16, 1958
595,739	Great Britain	Dec. 15, 1947
597,935	Great Britain	Feb. 6, 1948
643,465	Great Britain	Sept. 20, 1956

UNITED STATES PATENT OFFICE
CERTIFICATE OF CORRECTION

Patent No. 2,984,712

May 16, 1961

George W. Fabel et al.

It is hereby certified that error appears in the above numbered patent requiring correction and that the said Letters Patent should read as corrected below.

Column 4, line 26, after "flux" insert -- radially --.

Signed and sealed this 21st day of November 1961.

(SEAL)

Attest:

ERNEST W. SWIDER

Attesting Officer

DAVID L. LADD

Commissioner of Patents

USCOMM-DC