



Europäisches Patentamt  
European Patent Office  
Office européen des brevets



(11) **EP 1 026 324 A2**

(12) **EUROPEAN PATENT APPLICATION**

(43) Date of publication:  
**09.08.2000 Bulletin 2000/32**

(51) Int. Cl.<sup>7</sup>: **E01C 19/48**

(21) Application number: **00101625.2**

(22) Date of filing: **28.01.2000**

(84) Designated Contracting States:  
**AT BE CH CY DE DK ES FI FR GB GR IE IT LI LU  
MC NL PT SE**  
Designated Extension States:  
**AL LT LV MK RO SI**

(72) Inventor: **Bitelli, Romolo  
S. Lazzaro (BO) (IT)**

(74) Representative: **Bonini, Ercole  
c/o STUDIO ING. E. BONINI SRL  
Corso Fogazzaro 8  
36100 Vicenza (IT)**

(30) Priority: **01.02.1999 IT VI990006 U**

(71) Applicant: **BITELLI S.p.A.  
40061 Minerbio (BO) (IT)**

(54) **Vibratory finishing machine**

(57) The finding produces a self-propelled vibratory finishing machine (1) for asphaltting road surfaces (5) comprising a frame (2) which supports storage means (4) and distribution of the bitumen (B) to be deposited on the surfaces (5) comprising a pair of screw feeders (6) moved by a transmission unit (8) and pressing means (9) the deposited bitumen aggregate (B) set

behind the screw feeders (6). Connected to the transmission unit and next to the screw feeders (6) there is a flow divider device (12) having surfaces (13, 14, 15, 16) symmetrically shaped to create at least one cutting edge (18) suited to aid the flow of bitumen (B) towards the screw feeders (6)

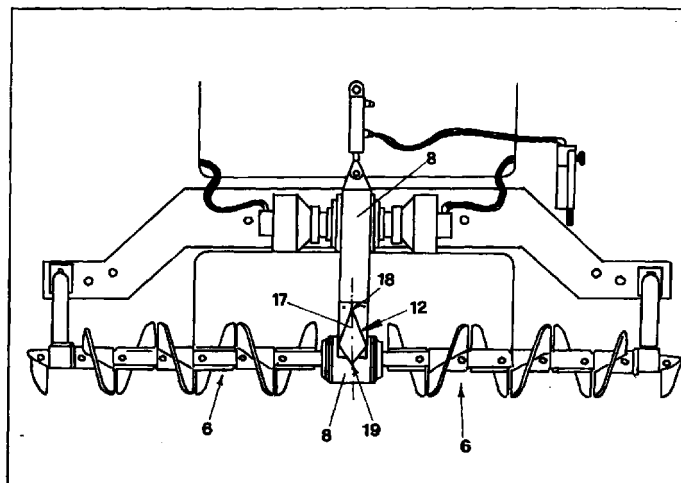

**FIG.2**

**EP 1 026 324 A2**

## Description

**[0001]** This finding concerns a vibratory finishing machine especially suited for uniformly depositing bitumen aggregate on surfaces to be asphalted.

**[0002]** It is known that in road asphaltting work common use is made of self-propelled machines called vibratory finishing machines which basically consist of a frame shaped to provide a drivers cab and which houses the means of traction of the machine itself.

**[0003]** What's more the frame also holds a hopper with mobile walls containing the hot bitumen aggregate that, when retrieved by a conveyor belt, is deposited on the surface being asphalted.

**[0004]** The bitumen aggregate is then uniformly spread onto the surface being asphalted by the action of a pair of screw feeders standing side by side and set crossways to the machine's direction of travel and rotated by a transmission unit that connects them next to the machine's centreline.

**[0005]** While the bitumen aggregate is still hot it is uniformly spread over the road surface being asphalted and then compacted by the action of a device called a "vibrating compactor" set behind the screw feeders with respect to the machine's direction of travel.

**[0006]** The vibratory compactor comprises a plowshare consisting of a plate having a primarily longitudinal direction, set perpendicular to the surface being asphalted and crossways to the machine's direction of travel.

**[0007]** In particular the plowshare spreads the bitumen aggregate distributed by the screw feeders thereby preparing it for compacting by a beam, which is also set crossways to the machine's direction of travel and made to oscillate vertically by a device connected to it.

**[0008]** The main inconvenience of the machine described above is that the flow of bitumen aggregate transported by the conveyor belt engulfs the space between the screw feeders and the plowshare creating a build up of bitumen aggregate against the transmission unit which leads to an uneven distribution of the bitumen aggregate on the road course, thereby requiring additional finishing by hand.

**[0009]** This build up is also aggravated by the machine's forward travel that pushes the bitumen aggregate against the plate.

**[0010]** Another inconvenience is that the build up of bitumen aggregate tends to cool and thereby consolidates, hampering the uniform distribution of bitumen aggregate on the surface being asphalted. This makes it necessary to remove the consolidated bitumen aggregate, which has to be carried out periodically by an operator who has to follow the machine throughout the work cycle.

**[0011]** Last but not least, an inconvenience is caused by the risk the operator runs while removing the consolidated bitumen aggregate, since he has to remove the bitumen aggregate with a spade in close

proximity to the rotating screw feeders.

**[0012]** This finding intends to remedy the aforementioned inconveniences.

5 **[0013]** The main scope of the finding is to produce a machine that allows to deposit the bitumen coarse in an even, uniform manner over the whole surface being treated.

10 **[0014]** Last but not least, a scope is to produce a machine that eliminates the build-up of hot bitumen aggregate and its consequent cooling.

**[0015]** Another scope is to produce a machine that does not require the intervention of operators during the work cycle.

15 **[0016]** The aforesaid scopes are achieved by a self-propelled vibratory finishing machine for asphaltting road surfaces that in accordance with the main claim comprises a frame, housing a means of traction, which is shaped to provide a drivers cab and that supports:

- 20 - storage means and distribution of the bitumen aggregate ready to be deposited on said surfaces comprising a pair of screw feeders working side by side mounted crossways to the direction of travel of said machine, moved by a transmission unit that connects them next to the machine's centreline;
- 25 - pressing means the deposited bitumen aggregate set behind said screw feeders and crossways to the direction of travel of said machine;

30 that is characterised in that it has, connected to said transmission unit and next to said screw feeders, a flow divider device basically consisting of faces symmetrically shaped around a vertical axis, converging towards said axis to create at least one cutting edge suited to aid the flow of bitumen aggregate towards said screw feeders.

**[0017]** An advantage of the finding is that it allows a uniform distribution of the bitumen aggregate deposited on the surface being asphalted.

40 **[0018]** Another advantage of the finding is that it allows a vibratory finishing machine to be produced that does not require periodical servicing by operators to guarantee an even deposit of bitumen aggregate.

**[0019]** The aforesaid scopes and advantages shall be better explained during the description of a preferred form of execution of the finding given as a guideline but not a limitation and illustrated in the attached diagrams, where:

- 50 - fig. 1 illustrates the vibratory finishing machine under this finding;
- fig. 2 illustrates a front view of part of the vibratory finishing machine in fig. 1;
- fig. 3 illustrates an isometric view of a detail of the machine in fig. 1;
- 55 - fig. 4 illustrates an isometric view of a detail of the machine in fig. 1;
- fig. 5 illustrates a side view of part of the machine in

fig. 1.

**[0020]** The vibratory finishing machine under this finding is illustrated in fig. 1, where it is indicated as a whole by 1.

**[0021]** It essentially comprises a frame 2, which is shaped to provide a drivers cab 3 and that houses the machine's means of traction.

**[0022]** The frame 2 also supports storage means consisting of a mobile walled hopper 4 containing the hot bitumen aggregate B that is retrieved by a conveyor belt, not illustrated, to be deposited on the surface being asphalted 5.

**[0023]** The deposited aggregate B is then uniformly distributed onto the surface being asphalted 5 by the action of a pair of screw feeders 6 standing side by side, set to the rear of the machine 1 and crossways to the direction of travel 7 of the machine 1, moved by a transmission unit 8, illustrated in detail in fig.'s 2 and 3, that connects them next to the machine's centreline 1.

**[0024]** The bitumen aggregate B is then compacted by a device, called a vibratory compactor generally indicated by 9 in fig. 1, set behind the screw feeders 6, with respect to the direction of travel 7 of the machine 1.

**[0025]** The vibratory compactor 9 comprises a plowshare consisting of a plate 10 having a primarily longitudinal direction set perpendicular to the surface 5 being asphalted and crossways to the direction of travel 7 of the machine 1.

**[0026]** The plowshare spreads the bitumen aggregate B distributed by the screw feeders 6 and prepares it for compacting by an oscillating beam 11, also mounted crossways to the direction of travel 7 of the machine 1, made to oscillate vertically by a device connected to it and not illustrated.

**[0027]** The finding prescribes that the transmission unit 8 is connected, next to the screw feeders 6, to a flow divider device 12 having a basically prismatic form and symmetrical around an axis 17, as illustrated in fig. 4, having surfaces 13 and 14, 15 and 16 converging towards the symmetrical axis 17 so that a top cutting edge 18 and bottom cutting edge 19 are created.

**[0028]** A plate 21, connected to the flow divider device 12, having a series of through holes 22 enables it, by a means of fixing such as screws or similar not illustrated, to be applied to the transmission unit 8.

**[0029]** The bitumen aggregate B that is transported by the conveyor belt 20, as can be seen in detail in fig. 3, falls by gravity towards the surface being asphalted 5, and encounters the top cutting edge 18 and surfaces 13 and 14 which prevent any build ups and aid the flow of bitumen aggregate B towards the screw feeders 6.

**[0030]** The build up of bitumen aggregate B around the transmission unit 6 caused by the machine's travel 1 is prevented in a similar manner by the action of surfaces 15, 16 and the bottom cutting edge 19.

**[0031]** In this way the flow of bitumen aggregate never encounters blind zones where it may settle, cool

and consolidate, since it is continuously directed in motion, by the combined action of gravity and the machine's travel 1, towards the screw feeders 6, which by rotating spread the bitumen aggregate B sideways.

5 **[0032]** It is clear that the flow divider device may take on any form, having curved surfaces and more, so long as the shape and position are such that the deposited bitumen aggregate is kept mixed.

10 **[0033]** In a similar way any quantity of these flow divider devices may be mounted on the machine as their size may differ.

### Claims

15 1. Vibratory finishing machine (1) self-propelled for asphaltting road surfaces (5) comprising a frame (2), housing a means of traction, which is shaped to provide a drivers cab (3) and that supports:

- 20 - storage means (4) and distribution of the bitumen aggregate (B) to be deposited on said surfaces (5) comprising a pair of screw feeders (6) standing side by side and crossways set to the direction of travel (7) of said machine (1), moved by a transmission unit (8) that connects them next to the machine's centreline;
- 25 - pressing means (9) the bitumen aggregate deposited (B) set behind said screw feeders (6) and crossways to the direction of travel (7) of said machine (1);
- 30

**characterised in that**, connected to said transmission unit and next to said screw feeders (6) it has a flow divider device (12) having surfaces (13, 14, 15, 16) symmetrically shaped around a vertical axis (17), converging towards said axis (17) to create at least one cutting edge (18) in the opposite direction to the flow of bitumen suited to aid the flow of bitumen aggregate (B) towards said screw feeders (6).

35

40 2. Vibratory finishing machine (1) according to claim 1), **characterised in that** said surfaces (13, 14, 15, 16) converge to create two cutting edges, one on top (18) and one at the bottom (19).

45 3. Vibratory finishing machine (1) according to claim 2) **characterised in that** said flow divider device (12) is a solid piece having a basically prismatic shape with bases of a rhombic form.

50

55 4. Vibratory finishing machine (1) according to claim 1), **characterised in that** said flow divider device (12) is connected to a plate (21) suited to allow the fixing of said flow divider (12) to said transmission unit (8).

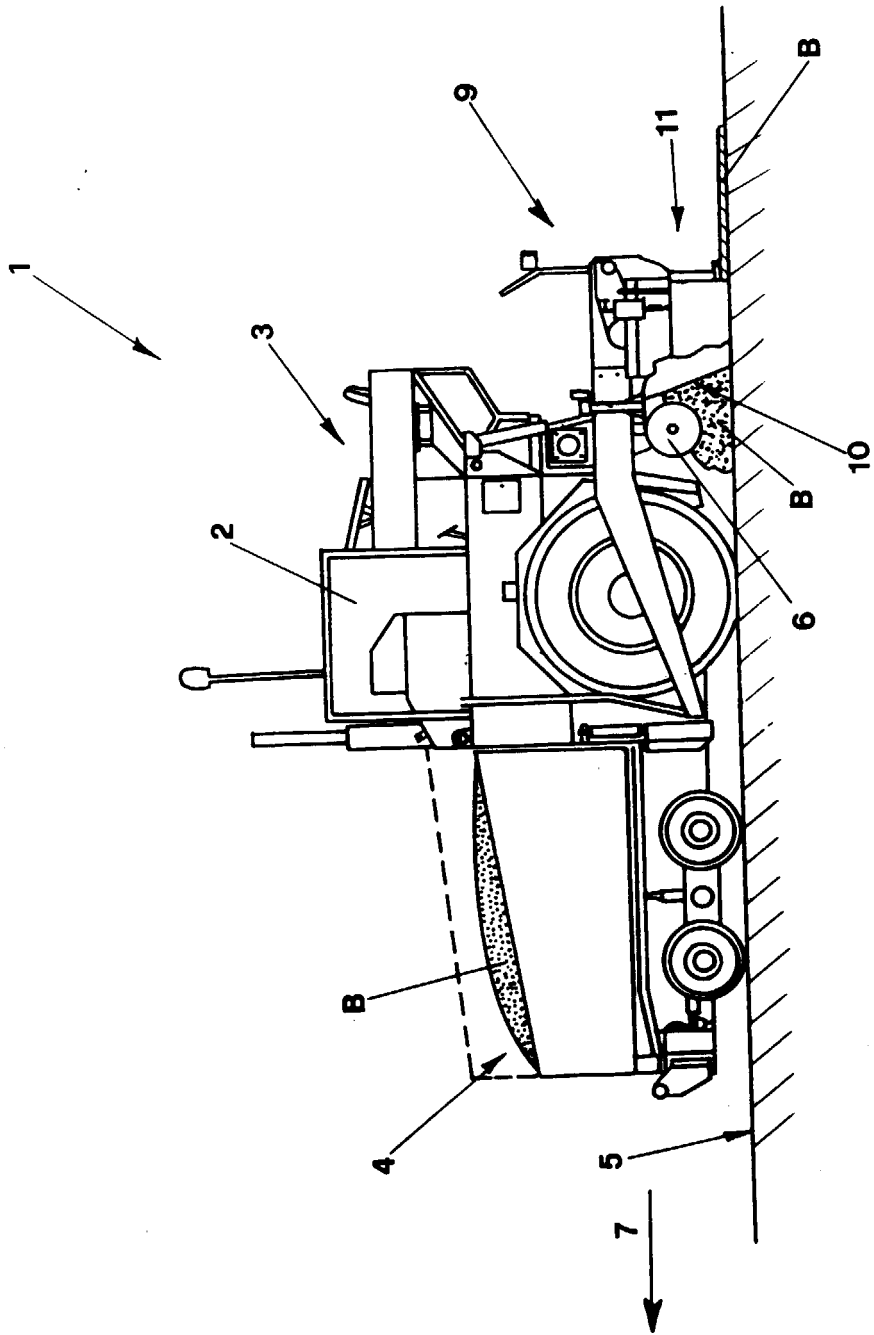

FIG.1

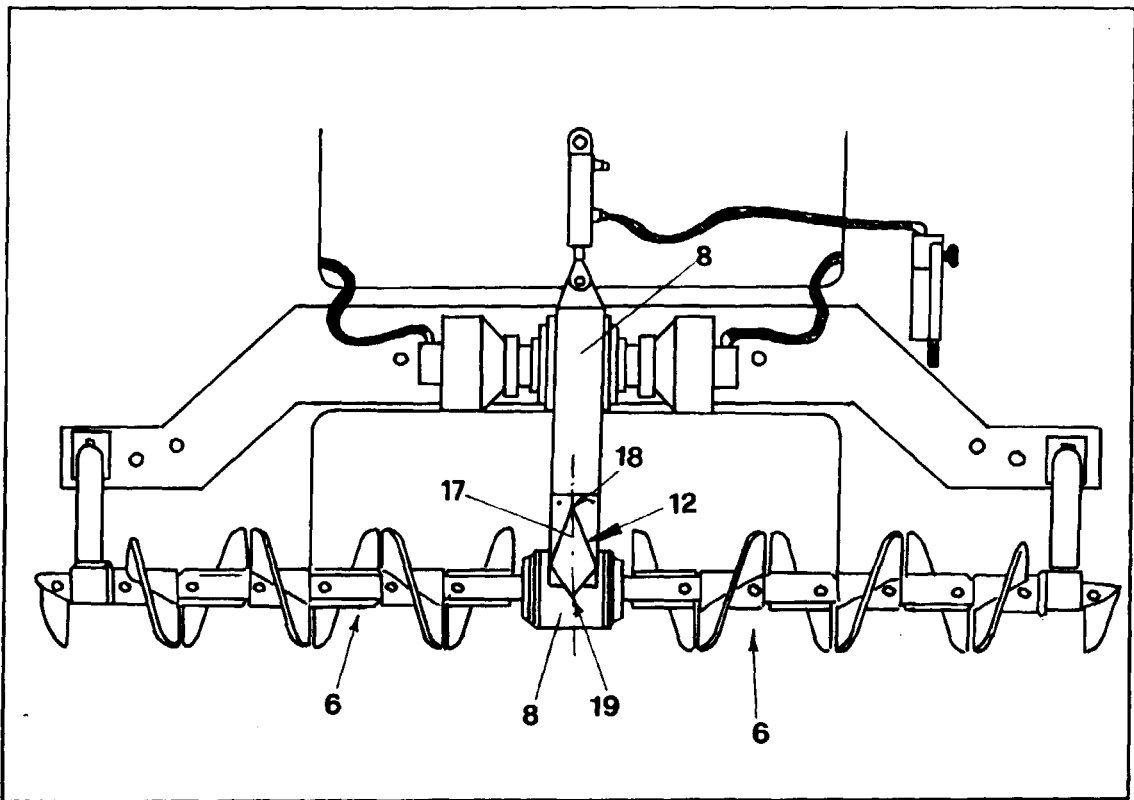

FIG.2

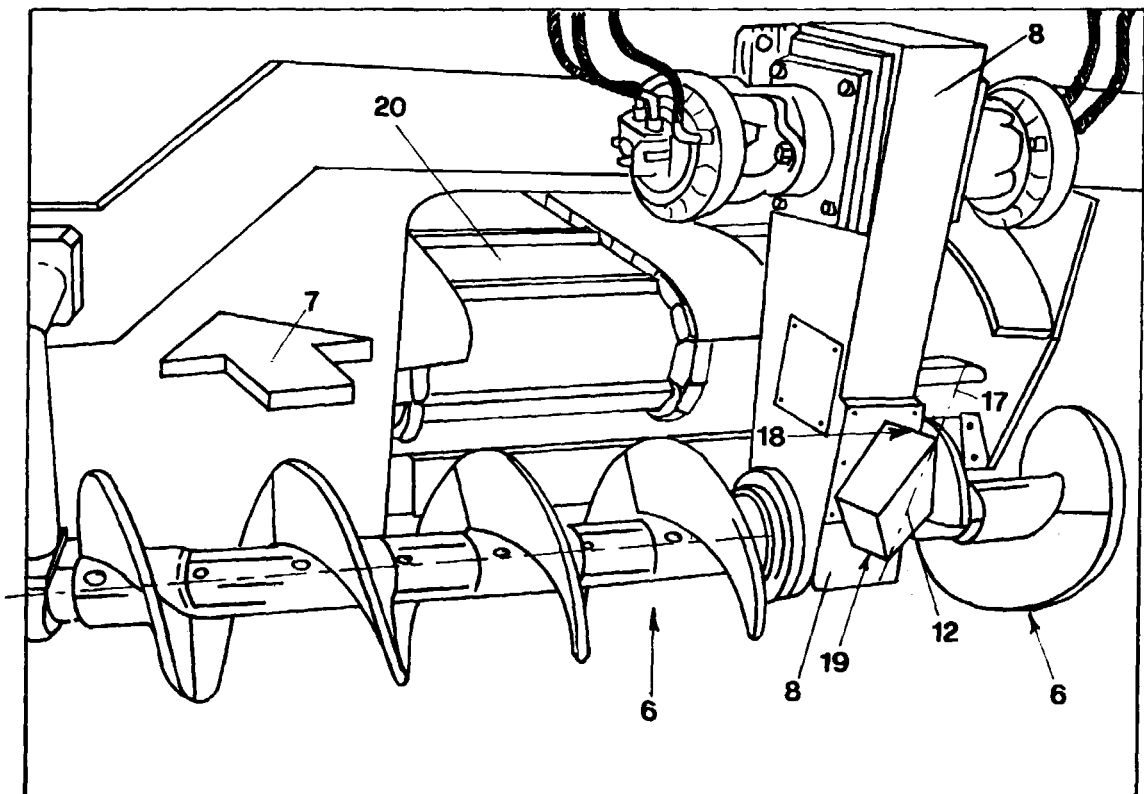

FIG.3

