

No. 653,397.

Patented July 10, 1900.

J. W. PETTIJOHN.
COUPLING.

(Application filed Nov. 13, 1899.)

(No Model.)

Fig. 1.

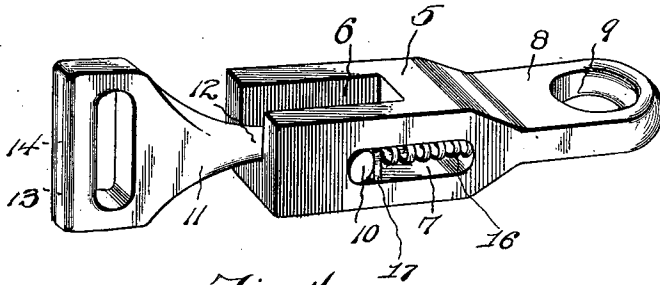

Fig. 4.

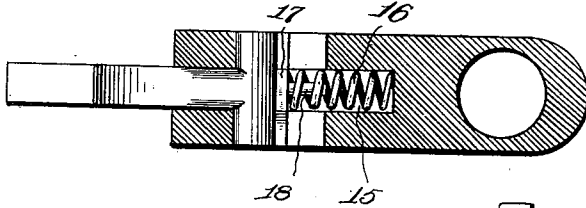

Fig. 2.

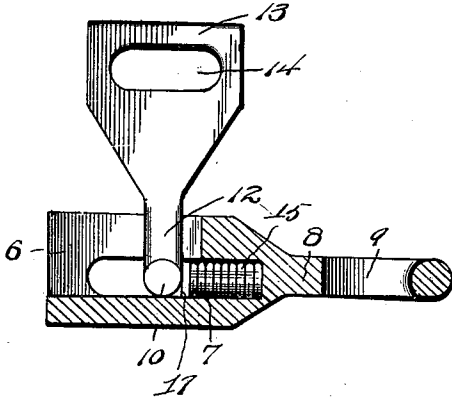

Fig. 3.

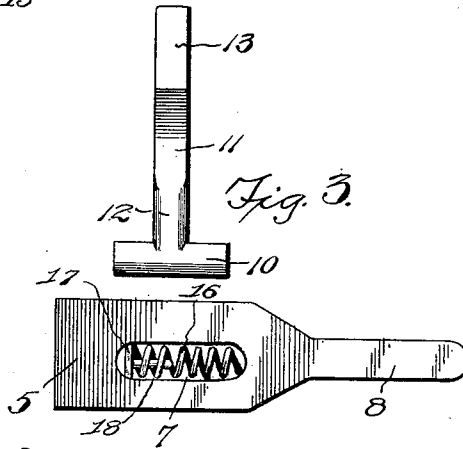
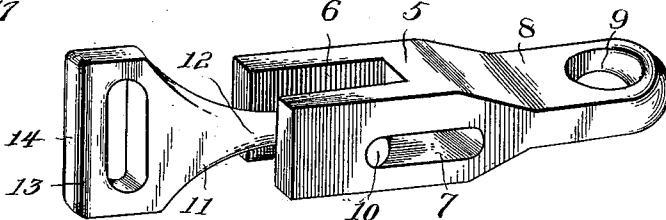

Fig. 5.



Witnesses

Ralph A. Shepard
Scott Chaudler

By *W. S.* Attorneys.

John W. Pettijohn, Inventor

C. Snow & Co.

UNITED STATES PATENT OFFICE.

JOHN W. PETTIJOHN, OF MONTESANO, WASHINGTON, ASSIGNOR OF ONE-HALF TO WILLIAM H. BUSH, OF SAME PLACE.

COUPLING.

SPECIFICATION forming part of Letters Patent No. 653,397, dated July 10, 1900.

Application filed November 13, 1899. Serial No. 736,826. (No model.)

To all whom it may concern:

Be it known that I, JOHN W. PETTIJOHN, a citizen of the United States, residing at Montesano, in the county of Chehalis and State of Washington, have invented a new and useful Coupling, of which the following is a specification.

This invention relates to couplings, and more particularly to that class employed for connecting the ends of cords or ropes, although it may be employed for connecting the ends of traces with the singletrees or may be used in any other case and in connection with any devices to which it is applicable.

The object of the invention is to provide a cheap and efficient construction in which the parts may be instantly connected or disconnected and in which they will be positively held together when in their operative positions.

In the drawings forming a portion of this specification, and in which similar numerals of reference designate like and corresponding parts in the several views, Figure 1 is a perspective view of the coupling, showing the parts connected. Fig. 2 is a view partially in section and partially in elevation and showing the positions of the parts when first moved to disengage them. Fig. 3 is a side elevation of the parts disengaged and showing their correlative positions when first separated. Fig. 4 is a vertical longitudinal section of the form of coupling shown in Fig. 1, one element being shown in elevation. Fig. 5 is a view similar to Fig. 1 with the spring-pressed follower omitted and the block slotted entirely through.

Referring now to the drawings, 5 represents the receiving element of the coupling, which consists of a block, in the upper face of which and opening through one end is a recess 6. Transversely of the block is formed a passage 7, the lower wall of which coincides in part with the lower wall of the recess 6, the passage extending inwardly beyond the inner end of the recess and having a perforation 15 in its end wall, the forward end of the passage terminating in the rear of the outer end of the block through which the recess is cut. In the perforation 15 is disposed a helical spring 16, which extends into the recess 6 and bears at

its opposite end against the follower 17, disposed transversely in the passage 7 and having a stud 18, which is encircled by the outer end of the spring to hold the latter against displacement. The rear extremity of this block is narrowed vertically, as shown at 8, and is provided with a perforation 9 to facilitate its attachment to a cord or other object to be coupled.

The second element 10 of the coupling is substantially T-shaped and comprises a cylindrical head 11 and a stem 12, the lower end of which is broadened, as shown at 13, in a plane at right angles to the extension of the head 10. In this broadened base is formed a passage 14, which facilitates the attachment of a strap, cord, or other article to be coupled. The elements of this coupling are preferably cast of any suitable material, and in assembling the elements the element 11 is first brought to lie above the recess 6, with its head 10 longitudinally thereof, after which the head is passed downwardly and into the recess, and one end is engaged with the follower 17, which is then pressed backwardly against the tendency of the spring 16 until the head 10 is in a position to be turned to cause the head to enter the passage 7, as shown in Fig. 2. The element 11 is then rocked forwardly into the position shown in Fig. 1 and is held in this position by the spring 16, and is thus connected with the element 5. To disengage the elements, they are moved in reverse order to that described.

In Fig. 5 of the drawings there is shown a modification which is similar to the structure just described, with the exception that instead of the recess 6 being formed part way through the block 5 it extends entirely through it vertically, so that the second element may be engaged or removed with respect thereto from either side.

In Fig. 5 of the drawings is shown also a modification in which the spring and the follower are omitted.

It will of course be understood that in practice the specific shapes of the different parts of the structure may be varied and that any desired materials and proportions may be used without departing from the spirit of the

invention. Also the spring and the spring-pressed plate may be omitted from the form shown in Fig. 1 of the drawings, if desired.

What is claimed is—

5 1. A coupling comprising an element hav-
ing a recess in one side and opening through
the end thereof, and a passage formed trans-
versely and opening into the recess, the ends
10 of the passage having continuous walls, and
a second element comprising a stem and a
head, the head being adapted to enter the
recess and to be turned to lie in the passage
with the stem projecting outwardly of the
15 passage through the end of the first-named
element.

2. A coupling comprising an element adapt-
ed for attachment to an article to be coupled
and having a recess in one face and opening
through its end, a passage through the ele-
20 ment opening into the recess, the ends of the
passage having continuous walls, and a sec-
ond element comprising a stem having an
enlarged base provided with a passage for
the attachment of an article to be coupled
25 and having a head, said head being adapted
to enter the recess of the first element and to
be turned therein to lie in the passage there-
of, the stem being adapted to lie in the recess
and to project outwardly thereof through the
30 end of the first element.

3. A coupling comprising a block having

intersecting passages, one of which extends
through an end of the block, a follower dis-
posed in the second passage, a spring for the
35 follower, and a second element comprising a
stem and a head, the head being adapted to
enter one of the passages against the tendency
of the follower and its spring, and to be
turned to lie in the second passage and with
40 its stem projecting outwardly through the end
of the block.

4. A coupling comprising an element hav-
ing a recess in one side and opening through
the end thereof, a perforation in the element
at the opposite end of the recess, a passage
45 formed transversely and opening into the re-
cess, the ends of the passage having contin-
uous walls, a follower in the passage, a spring
seated in the perforation and engaging the
follower, and a second element comprising a
50 stem and a head, the head being adapted to
enter the recess and to be turned to lie in the
passage with the stem projecting outwardly
of the passage through the end of the first-
named element.

In testimony that I claim the foregoing as
my own I have hereto affixed my signature in
the presence of two witnesses.

JOHN W. PETTIJOHN.

Witnesses:

B. C. CRANE,
A. P. WHITE.