



(11) **EP 2 244 017 B1**

(12) **EUROPEAN PATENT SPECIFICATION**

(45) Date of publication and mention of the grant of the patent:  
**20.02.2019 Bulletin 2019/08**

(51) Int Cl.:  
**F24C 15/04<sup>(2006.01)</sup>**

(21) Application number: **10003845.4**

(22) Date of filing: **10.04.2010**

---

(54) **KITCHEN OVEN COMPRISING KITCHEN OVEN DOOR AND STRUCTURAL ELEMENT**

**BACKOFEN MIT BACKOFENTÜR UND BAUELEMENT**

**FOUR DE CUISSON COMPRENANT UNE PORTE DE FOUR DE CUISSON ET UN ÉLÉMENT STRUCTUREL**

---

(84) Designated Contracting States:  
**AT BE BG CH CY CZ DE DK EE ES FI FR GB GR HR HU IE IS IT LI LT LU LV MC MK MT NL NO PL PT RO SE SI SK SM TR**

(30) Priority: **22.04.2009 IT BG20090007 U**

(43) Date of publication of application:  
**27.10.2010 Bulletin 2010/43**

(73) Proprietor: **Franke Technology and Trademark Ltd**  
**6052 Hergiswil (CH)**

(72) Inventors:  
• **The inventors have waived their right to be thus mentioned.**

(74) Representative: **Lemcke, Brommer & Partner**  
**Patentanwälte Partnerschaft mbB**  
**Siegfried-Kühn-Straße 4**  
**76135 Karlsruhe (DE)**

(56) References cited:  
**EP-A2- 1 055 882 WO-A2-2009/027011**  
**DE-U1- 29 912 626**

**EP 2 244 017 B1**

---

Note: Within nine months of the publication of the mention of the grant of the European patent in the European Patent Bulletin, any person may give notice to the European Patent Office of opposition to that patent, in accordance with the Implementing Regulations. Notice of opposition shall not be deemed to have been filed until the opposition fee has been paid. (Art. 99(1) European Patent Convention).

## Description

**[0001]** The present invention refers to a kitchen oven, comprising an oven with an oven face and an oven door.

**[0002]** Various types of kitchen oven doors are known, and in general they are all provided with one or more glass panels (or other materials suitable for high temperatures) for insulation of the glass combined with the door and in contact with the external environment.

**[0003]** Each glass panel is separated and spaced from the one nearby by means of appropriate spacers positioned laterally to the glass panels.

**[0004]** This is due essentially to the need to prevent dispersion of the heat to the outside and to avoid users accidentally sustaining burns when they come into contact with the outer glass.

**[0005]** During use of the oven, the glass can become dirty and may have to be cleaned. For easier and more effective cleaning of the glass panels, it is advisable to remove them from the door.

**[0006]** Since the hinge springs are sized to keep the door balanced when it is completely equipped, if the user removes one or more of the glass panels from the door, with the door mounted on the oven, the force exerted by the springs, since it is no longer compensated for by the weight of the glass, would cause the door to shut violently with the risk of injury.

**[0007]** The user is therefore obliged to remove the door from the oven in order to disassemble the glass panels for cleaning.

**[0008]** DE 299 12 626 U1 discloses a kitchen oven door according to the preamble of claim 1, comprising two glass sheets and one fork-shaped retaining clip.

**[0009]** WO 2009/027011 A2 discloses a kitchen oven door comprising a retaining clip which can act as a structural element opposing the closure of the oven door.

**[0010]** EP 1 055 882 A2 discloses a domestic appliance hinging device comprising a door which comprises a hinge axle which is mounted at a housing part of an oven.

**[0011]** The object of the present invention is to provide a kitchen oven with a kitchen oven door being able to eliminate or at least drastically reduce the drawbacks of the known art.

**[0012]** A further object of the present invention is to make available a kitchen oven with an oven door which allows the glass panel(s) of the door to be removed in a simple manner.

**[0013]** A further object of the present invention is to obtain a kitchen oven with an oven door which is of simple construction and has a competitive production cost.

**[0014]** In accordance with the present invention, said objects and others are achieved by a kitchen oven, comprising an oven with an oven face and an oven door, the kitchen oven door comprising a perimeter framework; at least two sheet-like elements supported by said framework and removable from it; wherein it comprises at least one structural element having a first closed position and

a second open position; said structural element in said first closed position retains one of said at least two sheet-like elements; said structural element in said second open position releases one of said at least two sheet-like elements and opposes the closure of said door, when the kitchen oven door is in an open position in relation to the oven face wherein said at least one structural element comprises a fixed part and a movable part, characterized by said movable part being rotatable with respect to said fixed part so as to rest on the oven face in said second open position.

**[0015]** Further characteristics of the invention are described in the dependent claims.

**[0016]** The present solution integrates the function of releasing the inner glass panels with the function of preventing rotation of the unbalanced door.

**[0017]** When the movable part rotates, it rests on the face of the oven, preventing the door from closing even if the weight is reduced due to removal of the glass.

**[0018]** The characteristics and advantages of the present invention will be evident from the following detailed description of a practical embodiment thereof, illustrated by way of non-limiting example in the accompanying drawings, in which:

figure 1 shows an oven, seen in perspective, according to the present invention;

figure 2 shows an oven door, seen in perspective, according to the present invention;

figure 3 shows a portion of an oven with a catch of the door in the closed position, according to the present invention;

figure 4 shows a portion of an oven with a catch of the door in the open position, according to the present invention;

figure 5 shows a catch of the door seen in perspective in the closed position, according to the present invention;

figure 6 shows a fixed portion of a catch of the door, according to the present invention;

figure 7 shows a movable portion of a catch of the door, according to the present invention.

**[0019]** Referring to the attached figures, an oven 10, according to the present invention, comprises a cooking chamber 11 and a door 12 suitable for closing the chamber 11.

**[0020]** The door 12 consists of a perimeter framework comprising two lateral uprights 13 and an upper cross member 14 which retain, inside, three sheet-like elements (typically glass) 15, 16 and 17 respectively. They are opposite, spaced and parallel to one another, so that between the uprights 13, the cross member 14 and the three glass panels 15, 16 and 17, a thermally insulating cavity is formed.

**[0021]** In particular, the first glass 15 is the outer one with respect to the chamber 11, the second glass 16 is the intermediate one and the third glass 17 is the inner

one, i.e. the one facing the chamber 11.

**[0022]** In the embodiment example described here, there are three glass panels but they can be of any number.

**[0023]** The perimeter framework of the door 12 is combined with the chamber 11 by means of a pair of hinges 18 and relative springs (not shown), suitable for allowing opening and closing of the door.

**[0024]** The hinges 18 are fixed laterally to and below the uprights 13.

**[0025]** The door 12 of the oven furthermore comprises, in the vicinity of the hinges 18, two blocks 19, composed of a fixed part 20, integral with the uprights 13, and a movable part 21.

**[0026]** The uprights 13 comprise a U-shaped bar inside which, at their lower end, the hinges 18 are fixed.

**[0027]** The two blocks 19 are fixed laterally to the U-shaped bar, at their lower end, in the inner part of the door 12, beside the hinges 18.

**[0028]** The fixed part 20 has a foot 30, which extends externally and at the bottom on a short side of the fixed part 20.

**[0029]** On a short side of the movable part 21, a portion 29 extends beyond the fixed part 20, on the side of the foot 30, and opposes it. The block 19 seen laterally has a substantially U-shaped form rotated by 90°.

**[0030]** The blocks 19, both the movable part 21 and the fixed part 20 (with the exception of the foot 30) substantially both have the form of a parallelepiped, with the fixed part 20 of larger dimensions (height) than the movable part 21, which rotates.

**[0031]** The fixed part 20 comprises two holes. A first hole 31 is positioned crosswise in order to fix the block 19, by means of a screw or bolt, on the upright 13. A second hole 32 positioned vertically on the fixed part 20, opposite the foot 30, is provided in order to cooperate with a pin 33, positioned on the movable part 21. In this way the movable part 21 can rotate around the pin 33. The pin 33 is positioned substantially in the vicinity of a short side of the movable part 21, and laterally to a central axis of the movable part 21.

**[0032]** Beside the pin 33, on the surface of the movable part 21 which faces the fixed part 20, there is a protrusion 40 which fits into a slot 41 beside the hole 32 of the fixed part 20, which during the movement of the movable part 21 is below the undercut 42 positioned around the hole 32.

**[0033]** On a circumference coaxial with that of the pin 33, a protrusion 43 in the form of an arc of a circle is positioned. The protrusion 43 runs in the circular slot 44, positioned around the hole 32, which acts as a guide during rotation of the movable part 21. The protrusion 43 comprises, in its central part, raised elements 45 which cooperate with grooves 46 positioned along a longitudinal central axis of the fixed part and temporarily block the movable part 21 in the open and closed position.

**[0034]** A slot 34 which represents an arc of a circle is also provided on the fixed part 20. It is positioned in the

vicinity of the foot 30 and therefore opposite the hole 32. It has a radius of curvature equal to the distance between this slot 34 and the centre of the hole 32.

**[0035]** The slot 34 terminates on one side in a blind part while on the other it is accessible throughout its depth, which is equal to the height of the fixed part 20 minus the height of the foot 30.

**[0036]** The movable part 21, at the level of the slot 34, has a protrusion 35 in the form of an arc of a circle. The protrusion 35 runs in the slot 34, which acts as a guide, during rotation of the movable part 21.

**[0037]** Laterally to the movable part 21, at the height of the profile 35, a bar 36 which terminates in a chamfered foot 37 is connected perpendicular to said movable part.

The foot 37 is fixed perpendicular to the bar 36, in a direction internal to the movable part 21.

**[0038]** Said chamfered foot 37 cooperates with a chamfer 38 made in the fixed part 20 in the vicinity of the slot 34, so that when the movable part is re-closed, the foot 37 and the chamfer 38 interfere with one another, thus avoiding accidental opening of the movable part 21.

**[0039]** The block 19 is preferably made of plastic able to withstand the oven temperatures.

**[0040]** Any materials and dimensions can be used, however, according to requirements and the state of the art.

**[0041]** Operation of the device according to the invention is evident from what is described and illustrated and, in particular, is substantially as follows.

**[0042]** The movable part 21 of the blocks 19, in the closed position, has the portion 29 which develops externally to the fixed central part 20 and opposes at least partially the foot 30. In the closed position, the block 19 with the outer part 29 of the movable part 21 retains the outer glass in position and the foot 30 sustains the inner glass.

**[0043]** The movable part 21 can rotate 180° on the pin 33 to reach an open position.

**[0044]** In this position, as the pin is out of line with respect to the main axis of the fixed part 20, it is extended externally with respect to the fixed part 20, in an opposite position with respect to the foot 30.

**[0045]** In this way its outer end rests on the face 22 of the oven, preventing the door 12 from closing also when the weight is reduced due to removal of the glass panels.

**[0046]** Face 22 indicates for example the border of the chamber 11 which abuts against the door 12.

**[0047]** Since the glass panels are no longer retained by the block 19 in the closed position, they can be removed and cleaned, but the door 12 cannot re-close.

**[0048]** Once the glass panels have been cleaned, they are re-positioned and the movable part 21 is rotated again by 180°; the door can then be closed and the glass panels are retained in position by the portion 29 of the movable part 21 which extends beyond the fixed part 20.

## Claims

1. A kitchen oven, comprising an oven (10) with an oven face (22) and an oven door (12), the kitchen oven door (12) comprising a perimeter framework; at least two sheet-like elements (15, 16, 17) supported by said framework and removable from it; wherein it comprises at least one structural element (20, 21) having a first closed position and a second open position; said structural element (20, 21) in said first closed position retains one of said at least two sheet-like elements (17); said structural element (20, 21) in said second open position releases one of said at least two sheet-like elements (17) and opposes the closure of said door (12), when the kitchen oven door (12) is in an open position in relation to the oven face (22) wherein said at least one structural element (20, 21) comprises a fixed part (20) and a movable part (21), **characterized by** said movable part (21) being rotatable with respect to said fixed part (20) so as to rest on the oven face (22) in said second open position.
2. The device as claimed in claim 1 **characterised in that** said structural element (20, 21) in said second open position opposes the face (22) of said oven (10).
3. The device as claimed in claim 1 **characterised in that** said at least two sheet-like elements (15, 16, 17) are made of vitreous material.
4. The device as claimed in claim 1, **characterised in that** said at least one structural element (20, 21) passes from said first closed position to said second open position by means of rotation.
5. The device as claimed in claim 1 **characterised in that** said at least one structural element (20, 21) in said first closed position comprises said movable part (21) which extends in a first direction with respect to said fixed part (20), retaining one of said at least two sheet-like elements (17).
6. The device as claimed in claim 5 **characterised in that** said at least one structural element (20, 21) in said second open position comprises said movable part (21) which extends in a second direction with respect to said fixed part (20) so as to rest on the face (22) of said oven (10).
7. The device as claimed in claim 6 **characterised in that** said movable part (21) rotates with respect to said fixed part (20), thus setting said at least one structural element (20, 21) to said first closed position or said second open position.

## Patentansprüche

1. Küchenofen, umfassend einen Ofen (10) mit einer Ofenvorderseite (22) und einer Ofentür (12), wobei die Küchenofentür (12) ein umlaufendes Rahmenwerk umfasst; mindestens zwei plattenartige Elemente (15, 16, 17), die von dem Rahmenwerk getragen werden und von ihm abnehmbar sind; wobei er mindestens ein Bauelement (20, 21) umfasst, das eine erste, geschlossene Position und eine zweite, offene Position hat; wobei das Bauelement (20, 21) in der ersten, geschlossenen Position eines der mindestens zwei plattenartigen Elemente (17) festhält; das Bauelement (20, 21) in der zweiten, offenen Position eines der mindestens zwei plattenartigen Elemente (17) freigibt und das Schließen der Tür (12) verhindert, wenn die Küchenofentür (12) in einer offenen Position in Bezug auf die Ofenvorderseite (22) ist, wobei das mindestens eine Bauelement (20, 21) ein festes Teil (20) und ein bewegliches Teil (21) umfasst, **dadurch gekennzeichnet, dass** das bewegliche Teil (21) bezüglich des festen Teils (20) so drehbar ist, dass es in der zweiten, offenen Position gegen die Ofenvorderseite (22) zu liegen kommt.
2. Vorrichtung gemäß Anspruch 1, **dadurch gekennzeichnet, dass** das Bauelement (20, 21) in der zweiten, offenen Position der Vorderseite (22) des Ofens (10) gegenüberliegt.
3. Vorrichtung gemäß Anspruch 1, **dadurch gekennzeichnet, dass** die mindestens zwei plattenartigen Elemente (15, 16, 17) aus einem glasartigen Material hergestellt sind.
4. Vorrichtung gemäß Anspruch 1, **dadurch gekennzeichnet, dass** das mindestens eine Bauelement (20, 21) durch Drehung von der ersten, geschlossenen Position in die zweite, offene Position gelangt.
5. Vorrichtung gemäß Anspruch 1, **dadurch gekennzeichnet, dass** das mindestens eine Bauelement (20, 21) in der ersten, geschlossenen Position das bewegliche Teil (21) umfasst, das sich in einer ersten Richtung bezüglich des festen Teils (20) erstreckt, wobei es eines der mindestens zwei plattenartigen Elemente (17) festhält.
6. Vorrichtung gemäß Anspruch 5, **dadurch gekennzeichnet, dass** das mindestens eine Bauelement (20, 21) in der zweiten, offenen Position das bewegliche Teil (21) umfasst, das sich in einer zweiten Richtung so bezüglich des festen Teils (20) erstreckt, dass es gegen die Vorderseite (22) des Ofens (10) zu liegen kommt.
7. Vorrichtung gemäß Anspruch 6, **dadurch gekenn-**

**zeichnet, dass** das bewegliche Teil (21) sich bezüglich des festen Teils (20) dreht, wodurch das mindestens eine Bauelement (20, 21) in der ersten, geschlossenen Position oder der zweiten, offenen Position eingestellt wird.

5

dans ladite deuxième position ouverte comprend ladite partie mobile (21) laquelle s'étend dans une deuxième direction par rapport à ladite partie fixe (20), de sorte à reposer sur la face (22) dudit four (10).

## Revendications

1. Four de cuisson, comprenant un four (10) ayant une face avant (22) et une porte de four (12), la porte de four de cuisson (12) comprenant un cadre périphérique ; au moins deux éléments de type feuillet (15, 16, 17) supportés par ledit cadre et pouvant être retirés de celui-ci ; où il comprend au moins un élément structurel (20, 21) présentant une première position fermée et une deuxième position ouverte ; ledit élément structurel (20, 21) dans ladite première position fermée retient l'un desdits au moins deux éléments de type feuillet (17) ; ledit élément structurel (20, 21) dans ladite deuxième position ouverte libère l'un desdits au moins deux éléments de type feuillet (17) et s'oppose à la fermeture de ladite porte (12), lorsque la porte de four de cuisson (12) se trouve dans une position ouverte par rapport à la face de four (22), où ledit au moins un élément structurel (20, 21) comprend une partie fixe (20) et une partie mobile (21), **caractérisé par le fait que** ladite partie mobile (21) peut être pivotée par rapport à ladite partie fixe (20) de sorte à reposer sur la face de four (22) dans ladite deuxième position ouverte.
2. Dispositif selon la revendication 1, **caractérisé en ce que** ledit élément structurel (20, 21) dans ladite deuxième position ouverte s'oppose à la face (22) dudit four (10).
3. Dispositif selon la revendication 1, **caractérisé en ce que** lesdits au moins deux éléments de type feuillet (15, 16, 17) sont constitués d'un matériau vitreux.
4. Dispositif selon la revendication 1, **caractérisé en ce que** ledit au moins un élément structurel (20, 21) passe de ladite première position fermée à ladite deuxième position ouverte par pivotement.
5. Dispositif selon la revendication 1, **caractérisé en ce que** ledit au moins un élément structurel (20, 21) dans ladite première position fermée comprend ladite partie mobile (21) laquelle s'étend dans une première direction par rapport à ladite partie fixe (20), en retenant l'un desdits au moins deux éléments de type feuillet (17).
6. Dispositif selon la revendication 5, **caractérisé en ce que** ledit au moins un élément structurel (20, 21)

10

15

20

25

30

35

40

45

50

55

7. Dispositif selon la revendication 6, **caractérisé en ce que** ladite partie mobile (21) pivote par rapport à ladite partie fixe (20), en plaçant ainsi ledit au moins un élément structurel (20, 21) à ladite première position fermée ou à ladite deuxième position ouverte.

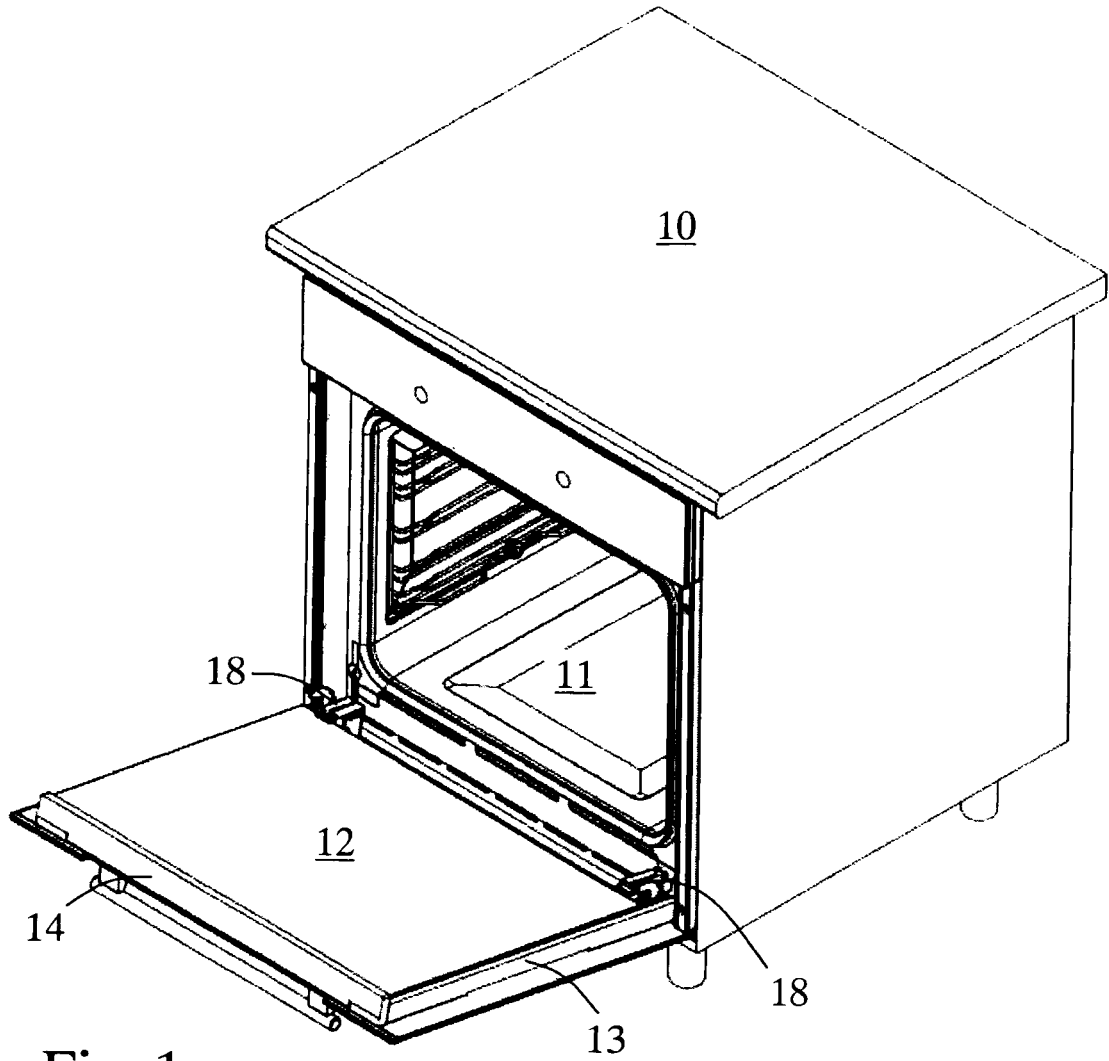

Fig. 1

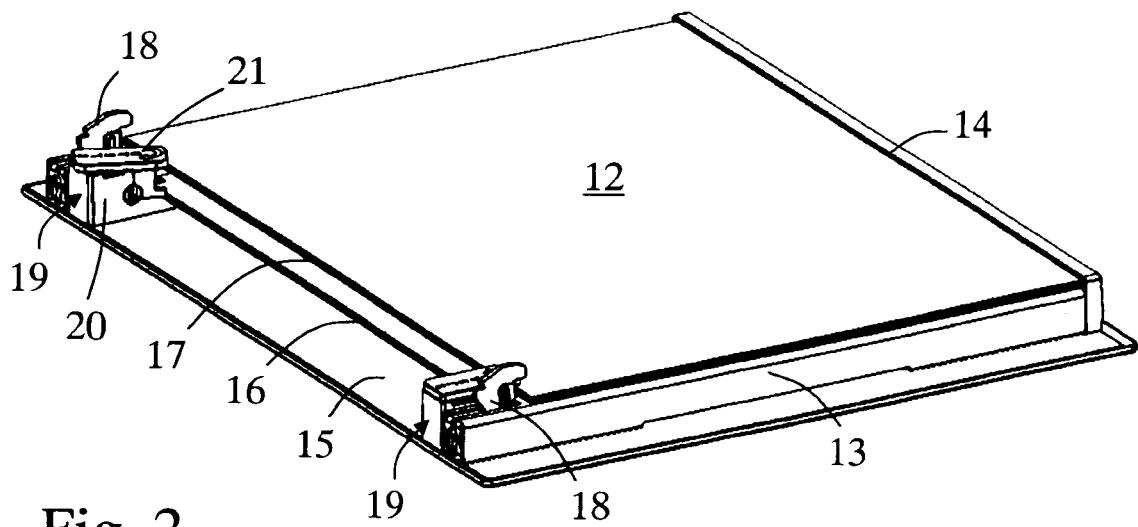

Fig. 2

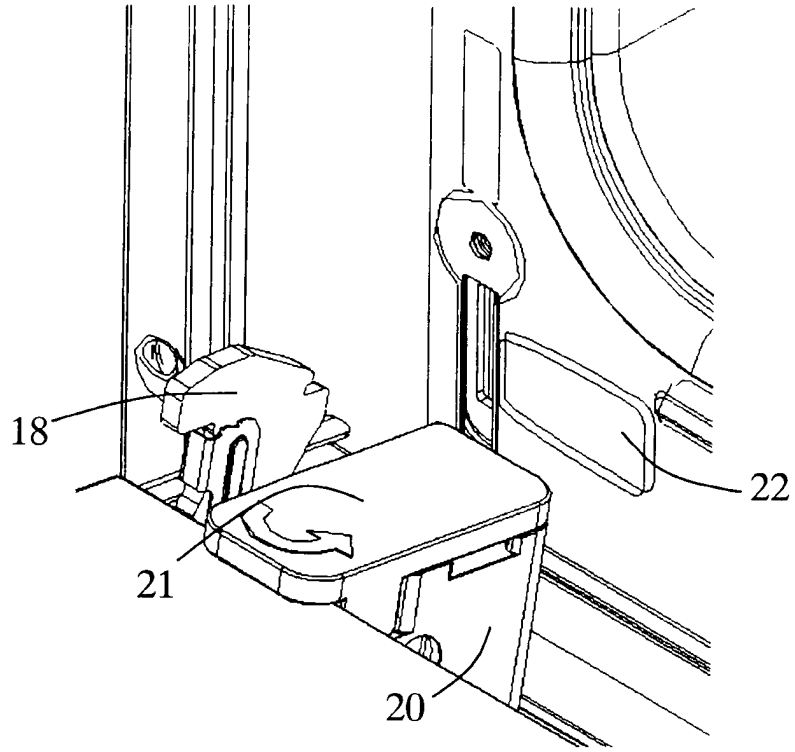

Fig. 3

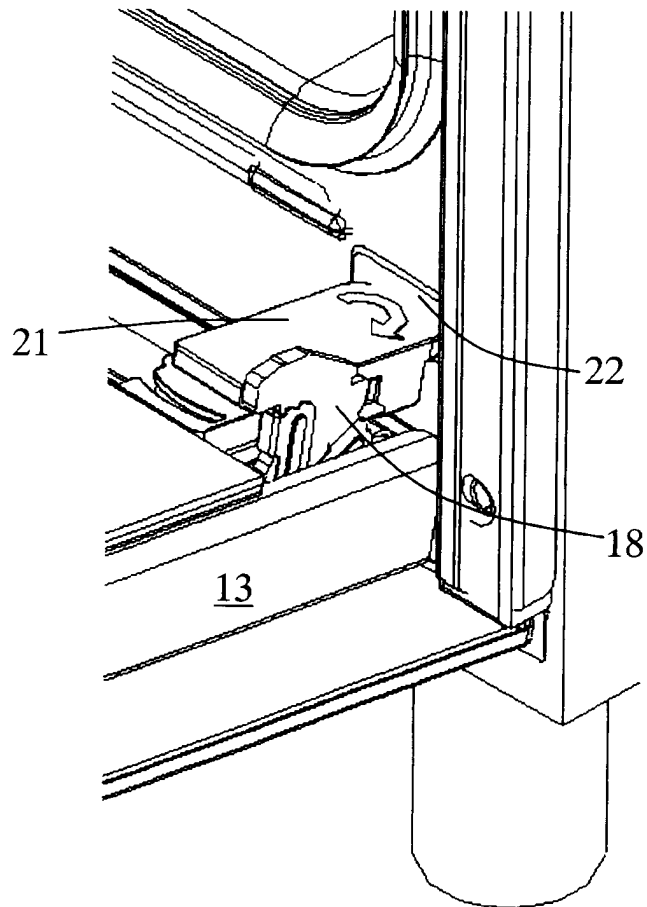

Fig. 4

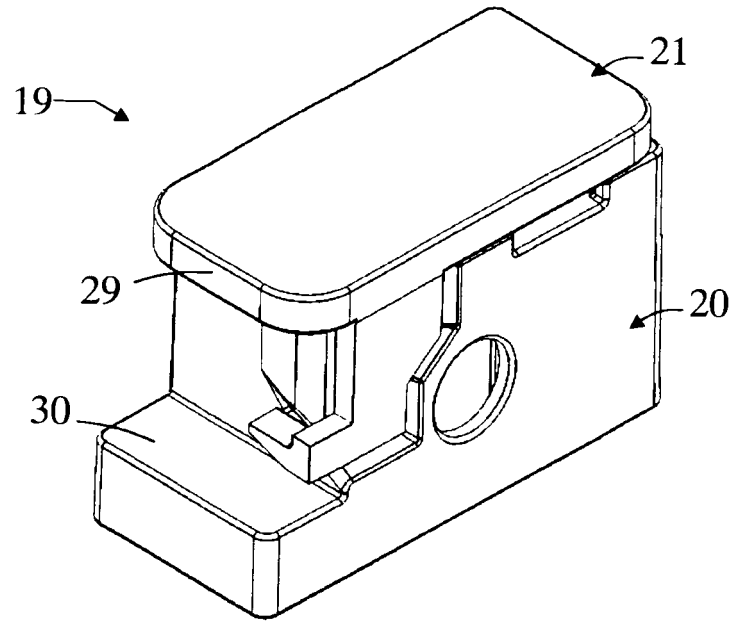

Fig. 5

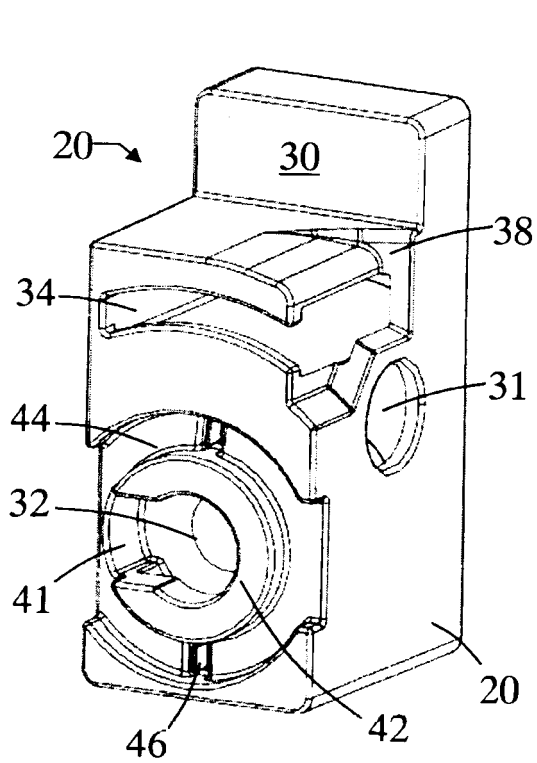

Fig. 6

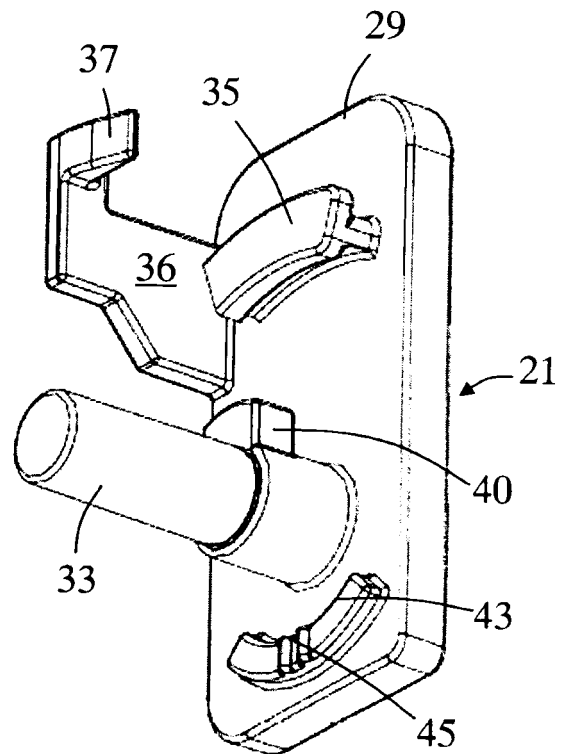

Fig. 7

**REFERENCES CITED IN THE DESCRIPTION**

*This list of references cited by the applicant is for the reader's convenience only. It does not form part of the European patent document. Even though great care has been taken in compiling the references, errors or omissions cannot be excluded and the EPO disclaims all liability in this regard.*

**Patent documents cited in the description**

- DE 29912626 U1 [0008]
- WO 2009027011 A2 [0009]
- EP 1055882 A2 [0010]