

19



LE GOUVERNEMENT
DU GRAND-DUCHÉ DE LUXEMBOURG
Ministère de l'Économie

11

N° de publication :

LU509231

12

BREVET D'INVENTION

B1

21

N° de dépôt: LU509231

51

Int. Cl.:
E21B 1/00, E21C 25/00, E21D 1/00

22

Date de dépôt: 06/12/2024

30

Priorité:

72

Inventeur(s):
FAN Jiawen – China

43

Date de mise à disposition du public: 06/06/2025

74

Mandataire(s):
Patent42 SA – 4081 Esch-sur-Alzette (Luxembourg)

47

Date de délivrance: 06/06/2025

73

Titulaire(s):
SHANXI COAL TRANSPORTATION AND MARKETING
GROUP JINNENG COAL MINE ENGINEERING CO., LTD –
030002 Taiyuan City (China)

54

BLOWOUT PREVENTING DRILL BIT FOR COAL SEAM DRILLING CONSTRUCTION.

57

The present invention provides a blowout preventing drill bit for coal seam drilling construction, which relates to the field of mining engineering technology. The advantages of the present invention lie in: high-pressure water flows through a valve core and joint body to be sprayed out of a water outlet of a drill bit. When a borehole cannot be normally constructed due to high gas pressure or hole collapse water pressure, after pressure relief, gas, high-pressure water, and coal residue in the borehole will flow back into the drill bit through the water outlet of the drill bit. At this time, the first sector-shaped water outlet of a valve seat and the second sector-shaped water outlet of a valve core will close, effectively preventing high-pressure coal residue in the borehole from flowing back into the drill bit and drill pipe.

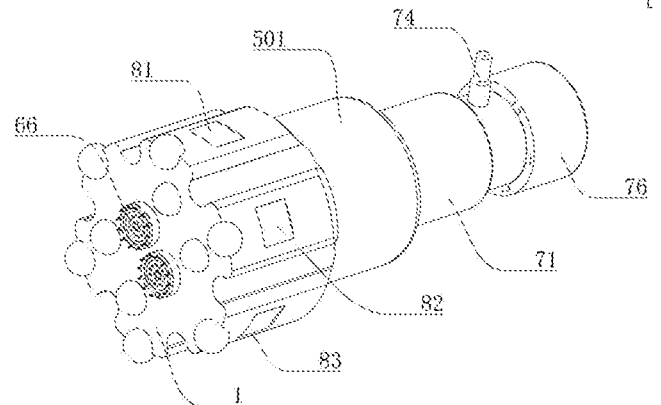

FIG. 1

DESCRIPTION

LU509231

BLOWOUT PREVENTING DRILL BIT FOR COAL SEAM DRILLING CONSTRUCTION
TECHNICAL FIELD

The present invention relates to the technical field of mine engineering, and in particular to a blowout preventing drill bit for coal seam drilling construction.

BACKGROUND

Gas outburst mostly occurs in the process of coal mining, and is often called "coal and gas outburst". Gas outburst is a special term for disaster, which refers to the formation of a geological disaster in the coal seam with the increase of coal mining depth and gas content. Under an action of ground stress and gravity of gas release, the weak coal seam breaks through a resistance line and instantly releases a large amount of gas and coal, which seriously threatens the safety production of coal mines. A coal seam drill bit is a type of drill bit used for drilling operations in coal seams.

In the prior art, in the process of drilling construction of high gas outburst coal seam, due to the release of gas stress in coal seam around a hole bottom, a large amount of gas carrying cinder and water is sprayed out in reverse direction along a drill pipe through the drill bit drainage hole, which is very easy to cause drill pipe blockage and injury accident. Therefore, a blowout preventing drill bit for coal seam drilling construction is provided.

SUMMARY

The present invention aims to provide a blowout preventing drill bit for coal seam drilling construction.

In order to solve the problems raised in the above background art, the present invention provides the following technical solution. A blowout preventing drill bit for coal seam drilling construction includes a drill bit 1 and a blowout preventing mechanism 5. A cinder intercepting mechanism 6 is arranged on a left side of the drill bit 1, a water pressure regulating mechanism 7 is arranged on a right side of the blowout preventing mechanism 5, and a monitoring mechanism 8 is arranged on an outer wall of the drill bit 1. The cinder intercepting mechanism 6 includes a mounting piece 61, an impact head 62 is fixedly mounted on an upper surface of the mounting piece 61, the mounting piece 61 is movably connected to a threaded piece 65 through a threaded groove 63, and the

threaded piece 65 is fixedly connected to a cinder intercepting grille 66 through a water pipe 64. LU509231

By adopting the technical solution, compared with the prior art, the present invention has the following advantages.

1. By the blowout preventing mechanism arranged in the present invention, during normal drilling operations, high-pressure water enters the two symmetrical first sector-shaped water outlet holes in the valve seat inside the drill bit through the drill pipe. Since the first sector-shaped water outlet holes of the valve seat and the second sector-shaped water outlet holes of the valve core are mutually staggered by 90 degrees, the valve core is forced open against the spring force by the high-pressure water within the drill pipe, allowing the high-pressure water to flow through the valve core and the joint body and spray out of the water outlet of the drill bit. When normal drilling operations cannot be performed due to high gas pressure or hole collapse water pressure, the operator outside the hole relieves the water pressure inside the drill pipe. At this point, gas, high-pressure water, and coal residue from within the borehole will flow back into the drill bit through its water outlet. By this time, the valve core, under the action of the spring when the drill pipe pressure is released, has tightly engaged with the valve seat, closing the first sector-shaped water outlet holes of the valve seat and the second sector-shaped water outlet holes of the valve core. This prevents high-pressure water and coal residue outside the drill bit from entering the drill bit and drill pipe, effectively stopping high-pressure coal residue within the borehole from backing up into the drill bit and drill pipe. This avoids the backflow of gas, high-pressure water, and coal residue from the borehole into the drill bit and drill pipe during drilling operations, thus preventing clogging of the drill pipe and accidents caused by injuries.

2. By the cinder intercepting mechanism arranged in the present invention, the cinder intercepting mechanism can directly intercept the coal cinder flowing back into the drill bit and the drill pipe on the outside of the drill bit through the coal cinder intercepting grille, prevent the coal cinder from entering the water outlet and causing the water outlet to be blocked. Meanwhile, the design of the threaded piece and threaded groove facilitates the cleaning and replacement of the coal residue interception grille in the later stage. Additionally, the impact head can be used to further crush the coal seam near the

water outlet, preventing larger coal residue in the vicinity from blocking the outlet and reducing the flow rate of high-pressure water. LU509231

3. By the water pressure regulating mechanism arranged in the present invention, the water pressure regulating valve can be connected to the drill bit through the first connecting pipe and the water pressure regulating valve and the drill pipe through the second connecting pipe, the water pressure can be flexibly regulated according to the actual drilling requirement to achieve the best drilling effect. The water pressure can be reduced in the softer coal seam, the water pressure can be appropriately increased in the harder coal seam, the energy waste caused by unnecessary high water pressure is avoided, the water pressure is prevented from being damaged to the drill bit and related equipment, and the drill bit can be better adapted to the complex and changeable underground environment.

4. By the monitoring mechanism arranged in the present invention, the working state of the drill bit and the coal quality condition outside the drill bit in real time can be monitored, feeding back the data to the control system, to timely adjust the drilling parameters or carry out early warning, effectively reducing the occurrence of safety incidents.

BRIEF DESCRIPTION OF THE DRAWINGS

FIG. 1 is a front view of a whole according to an example of the present invention;

FIG. 2 is a rear view of a whole according to the example of the present invention;

FIG. 3 is an explosion view of some structures according to the example of the present invention;

FIG. 4 is a schematic diagram of a partial structure according to the example of the present invention;

FIG. 5 is a explosion view of a partial structure of a blowout preventing mechanism according to the example of the present invention;

FIG. 6 is a cross-sectional view of a partial structure according to the example of the present invention;

FIG. 7 is a cross-sectional view of a partial structure of a blowout preventing mechanism according to the example of the present invention.

FIG. 8 is an explosion diagram of a cinder intercepting mechanism according to the

example of the present invention; and

LU509231

FIG. 9 is an explosion view of a water pressure regulating mechanism according to the example of the present invention.

Reference numerals and denotations thereof: 1-drill bit; 2-first groove; 3-water outlet; 4-second groove; 5-blowout preventing mechanism; 501-connecting rod; 502-first circlip; 503-valve seat; 504-first sector-shaped water outlet; 505-valve core; 506-second sector-shaped water outlet hole; 507-spring; 508-joint body; 509-second circlip; 510-seal piece; 6-cinder intercepting mechanism; 61-mounting piece; 62-impact head; 63-threaded groove; 64-water pipe; 65-threaded piece; 66-cinder intercepting grille; 7-water pressure regulating mechanism; 71-first connecting pipe; 72-first slot; 73-first plug pipe; 74-water pressure regulating valve; 75-second plug pipe; 76-second connecting pipe; 77-second slot; 8-monitoring mechanism; 81-pressure sensor; 82-temperature sensor; 83-vibration sensor; 84-rotational speed sensor; 85-displacement sensor; and 86-gas concentration sensor.

DETAILED DESCRIPTION

Specific examples of the present invention will be further described below with reference to the accompanying drawings, and it is noted that the description of the examples is intended to aid in understanding the present invention, but is not intended to limit the present invention.

In addition, technical features related to each example of the present invention described below may be combined with each other as long as they do not conflict with each other.

Please refer to FIGS. 1-9, the present invention is a blowout preventing drill bit for coal seam drilling construction includes a drill bit 1 and a blowout preventing mechanism 5. A cinder intercepting mechanism 6 is arranged on a left side of the drill bit 1, a water pressure regulating mechanism 7 is arranged on a right side of the blowout preventing mechanism 5, and a monitoring mechanism 8 is arranged on an outer wall of the drill bit 1. The blowout preventing mechanism 5 includes a connecting rod 501, the connecting rod 501 is fixedly connected to a valve seat 503 through a first circlip 502, a first sector-shaped water outlet hole 504 is disposed at an interior of the valve seat 503, a spring 507 is movably connected through a valve core 505, and a second sector-shaped

water outlet hole 506 is arranged at an interior of the valve core 505. The spring 507 is movably connected to a second circlip 509 through a joint body 508, and the cinder intercepting mechanism 6 includes a mounting piece 61, an impact head 62 is fixedly mounted on an upper surface of the mounting piece 61, the mounting piece 61 is movably connected to a threaded piece 65 through a threaded groove 63, and the threaded piece 65 is fixedly connected to a cinder intercepting grille 66 through a water pipe 64. LU509231

In one example of the present invention, six groups of first grooves 2 are disposed on the outer wall of the drill bit 1, the six groups of first grooves 2 are arranged in a circumferential array along the outer wall of the drill bit 1, and a water outlet 3 is arranged on a left side surface of the drill bit 1 near a middle position; and a second groove 4 is arranged on an outer side of the water outlet 3.

In one example of the present invention, a left end of the connecting rod 501 is fixedly mounted on a right end of the drill bit 1, the first circlip spring 502 is fixedly mounted on an inner wall of the connecting rod 501 near a right end position, and the valve seat 503 is fixedly mounted on a left end of the first circlip spring 502; and a seal piece 510 is fixedly mounted on an outer wall of the valve seat 503, and an outer wall of the seal piece 510 abuts against the inner wall of the connecting rod 501.

In one example of the present invention, the second circlip spring 509 is fixedly mounted on an inner wall of the drill bit 1, an left end of the joint body 508 is fixedly mounted at a right end of the second circlip spring 509, and a left end of the spring 507 is fixedly mounted at a right end of the joint body 508; the left end of the spring 507 is fixedly connected to a left end of the valve core 505, the valve core 505 is slidably connected to an interior of the drill bit 1, and a right end of the valve core 505 is abutted against a left end of the valve seat 503; and the first sector-shaped water outlet hole 504 and the second sector-shaped water outlet hole 506 are mutually staggered by ninety degrees.

In one example of the present invention, the impact heads 62 are distributed in the circumferential array along a surface of the mounting piece 61, a lower end of the mounting piece 61 is fixedly mounted at an interior of the second groove 4, and the threaded groove 63 is disposed on an inner wall of the mounting piece 61.

In one example of the present invention, the threaded piece 65 is fixedly mounted on an outer wall of the water pipe 64, the threaded piece 65 are threadedly connected to the threaded groove 63, and the cinder intercepting grille 66 is fixedly mounted on an inner wall of the water pipe 64 near an upper end position. LU509231

In one example of the present invention, the water pressure regulating mechanism 7 includes a first connecting pipe 71, a left end of the first connecting pipe 71 is fixedly mounted at a right end of the connecting rod 501, and a first slot 72 is disposed on an inner wall of a right end of the first connecting pipe 71; and a first plug pipe 73 is inserted at an interior of the first slot 72, and a water pressure regulating valve 74 is fixedly mounted at the right end of the first plug pipe 73.

In one example of the present invention, a second plug pipe 75 is fixedly mounted at the right end of the water pressure regulating valve 74, and the second plug pipe 75 is movably connected to a second connecting pipe 76 through a second slot 77.

In one example of the present invention: a monitoring mechanism 8 comprises a pressure sensor 81, a temperature sensor 82, a vibration sensor 83, a rotational speed sensor 84, a displacement sensor 85, and a gas concentration sensor 86; and the pressure sensor 81, the temperature sensor 82, the vibration sensor 83, the rotational speed sensor 84, the displacement sensor 85, and the gas concentration sensor are fixedly mounted at interiors of the six groups of first grooves 2.

Example 1. Please refer to FIGS. 1-7. Two symmetrical first sector-shaped water outlet holes 504 of the valve seat 503 and two symmetrical second sector-shaped water outlet holes 506 of the valve core 505 are 90 degrees staggered from each other. Under the action of high-pressure water in the drill pipe, the valve core 505 is pushed open against the elastic force of the spring 507. The valve core 505 separates from the valve seat 503, allowing water to flow out from the first sector-shaped outlet holes 504 of the valve seat 503 and then pass through the second sector-shaped outlet holes 506 of the valve core 505, eventually being ejected from the water outlet 3 through the joint body 508. When coal residue, gas, and high-pressure water surge back within the drilled hole, the valve core 505, under the action of the spring 507, abuts against the valve seat 503, blocking the communication between the first sector-shaped outlet holes 504 and the second sector-shaped outlet holes 506, thereby preventing the coal residue, gas, and

high-pressure water from being ejected back out through the drill pipe

LU509231

Example 2, please refer to FIGS. 1-8. the cinder intercepting grille 66 is fixedly mounted inside the water passage pipe 64, the water passage pipe 64 is threaded with the threaded groove 63 of the mounting piece 61 through the threaded piece 65, which is convenient to mount and disassemble the cinder intercepting grille 66, and the impact head 62 can further crush the coal seam near the water outlet 3 to avoid the larger cinder damaging the water outlet 3.

Example 3. please refer to FIGS. 1-2, the pressure sensor 81 is used for monitoring the pressure on the drill bit 1, understanding the change of resistance during drilling, and evaluating the hardness of the coal seam. The temperature sensor 82 is used for monitoring the temperature of the drill bit 1 when working to prevent damage or failure caused by excessive temperature. The vibration sensor 83 is used to sense the vibration situation of the drill bit 1, can find abnormal vibration in time, prompt possible failure or unstable state. The rotational speed sensor 84 is used to monitor the rotation speed of the drill bit 1 to ensure the appropriate drilling speed. The displacement sensor 85 is used to know the drilling depth and position of the drill bit 1, and the gas concentration sensor 86 is used to monitor the gas content to ensure the safety of the operation.

Specifically, through the blowout preventing mechanism 5, when the drill bit 1 is in normal construction, the high-pressure water enters two symmetrical first sector-shaped water outlet holes 504 of the valve seat 503 in the drill bit 1 through the drill pipe, because the first sector-shaped water outlet holes 504 of the valve seat 503 and the second sector-shaped water outlet holes 506 of the valve core 505 are mutually staggered at 90 degrees, the valve core 505 is pushed open under the action of the high-pressure water in the drill pipe, High-pressure water flows along the valve core 505 and the joint body 508, exiting through the outlet holes of the drill bit 1 at water outlet 3. When normal construction cannot be carried out due to high gas pressure or collapse-induced high water pressure within the borehole, operators outside the borehole relieve the water pressure inside the drill pipe. Subsequently, the gas, high-pressure water, and coal residue within the borehole will flow back into the drill bit 1 through the outlet at water outlet 3. At this point, the valve core 505, having been closely integrated with the valve seat 503 under the action of the spring 507 during the pressure

relief of the drill pipe, closes off the first fan-shaped outlet holes 504 of the valve seat 503 and the second fan-shaped outlet holes 506 of the valve core 505. This prevents high-pressure water and coal/rock residue outside the drill bit 1 from entering into the drill bit 1 and the drill pipe, effectively preventing the high-pressure cinder in the borehole from flowing back into the drill bit 1 and the drill pipe.

Specifically, through the arranged cinder intercepting mechanism 6, the cinder reversely flowing into the drill bit 1 and the drill pipe can be directly intercepted on the outside of the drill bit 1 through the cinder intercepting grille 66, to prevent the cinder from entering the water outlet 3 and causing the water outlet 3 to be blocked, and at the same time, it is convenient for later cleaning and replacement.

Specifically, through the arranged water pressure regulating mechanism 7, the water pressure regulating valve 74 and the drill bit 1 can be connected through the first connecting pipe 71, and the water pressure regulating valve 74 and the drill pipe can be connected through the second connecting pipe 76, and the water pressure can be flexibly adjusted according to the actual drilling requirements to achieve the best drilling effect.

Specifically, through the arranged monitoring mechanism 8, the working state of the drill bit 1 and the coal quality condition outside the drill bit 1 can be monitored in real time, and the data can be fed back to the control system to timely adjust drilling parameters or perform early warning, effectively reducing the occurrence of safety incidents.

Working principles

Firstly, the pressure sensor 81, the temperature sensor 82, the vibration sensor 83, the rotational speed sensor 84, the displacement sensor 85 and the gas concentration sensor 86 are fixedly mounted at the interior of the first groove 2, then the mounting piece 61 is fixedly mounted in the second groove 4, the water pipe 64 is threaded into the interior of the threaded groove 63 through the threaded piece 65, the first plug pipe 73 of the water pressure regulating valve 74 is inserted into the interior of the first slot 72 of the first connecting pipe 71, the second insertion pipe 75 of the water pressure regulating valve 74 is inserted into the second slot 77 of the second connecting pipe 76, and the drill bit is connected to the drill pipe, and then the water pressure is regulated by the water pressure regulating valve 74. At this time, when the drill bit 1 is in normal

construction, the high-pressure water enters two symmetrical first sector-shaped water outlet holes 504 of the valve seat 503 in the drill bit 1 through the drill pipe, because the first sector-shaped water outlet holes 504 of the valve seat 503 and the second sector-shaped water outlet holes 506 of the valve core 505 are mutually staggered at 90 degrees, the valve core 505 is pushed open under the action of the high-pressure water in the drill pipe, High-pressure water flows along the valve core 505 and the joint body 508, exiting through the outlet holes of the drill bit 1 at water outlet 3. When normal construction cannot be carried out due to high gas pressure or collapse-induced high water pressure within the borehole, operators outside the borehole relieve the water pressure inside the drill pipe. Subsequently, the gas, high-pressure water, and coal residue within the borehole will flow back into the drill bit 1 through the outlet at water outlet 3. At this point, the valve core 505, having been closely integrated with the valve seat 503 under the action of the spring 507 during the pressure relief of the drill pipe, closes off the first fan-shaped outlet holes 504 of the valve seat 503 and the second fan-shaped outlet holes 506 of the valve core 505. This prevents high-pressure water and coal/rock residue outside the drill bit 1 from entering into the drill bit 1 and the drill pipe, effectively preventing the high-pressure cinder in the borehole from flowing back into the drill bit 1 and the drill pipe. The cinder is blocked by the cinder intercepting grille 66 to effectively prevent the high pressure cinder in the drill bit 1 and the drill pipe. At the same time, during drilling, the pressure sensor 81, temperature sensor 82, vibration sensor 83, rotational speed sensor 84, displacement sensor 85, and gas concentration sensor 86 in the monitoring mechanism 8 can monitor in real-time the working state of the drill bit 1 and the coal quality conditions outside the drill bit 1. The data is fed back to the control system for timely adjustment of drilling parameters or early warning. At this point, the whole workflow is over.

Although the examples of the present invention have been described in detail above with reference to the accompanying drawings, the present invention is not limited to the described examples, and it will be understood by those skilled in the art that various changes, modifications, substitutions and modifications to the examples will still fall within the scope of protection of the present invention without departing from the principle and spirit of the present invention.

CLAIMS

LU509231

1. A blowout preventing drill bit for coal seam drilling construction, comprising a drill bit (1) and a blowout preventing mechanism (5), wherein a cinder intercepting mechanism (6) is arranged on a left side of the drill bit (1), a water pressure regulating mechanism (7) is arranged on a right side of the blowout preventing mechanism (5), and a monitoring mechanism (8) is arranged on an outer wall of the drill bit (1);

the blowout preventing mechanism (5) comprises a connecting rod (501), the connecting rod (501) is fixedly connected to a valve seat (503) through a first circlip (502), a first sector-shaped water outlet hole (504) is disposed at an interior of the valve seat (503), a spring (507) is movably connected through a valve core (505), and a second sector-shaped water outlet hole (506) is arranged at an interior of the valve core (505); and the spring (507) is movably connected to a second circlip (509) through a joint body (508); and

the cinder intercepting mechanism (6) comprises a mounting piece (61), an impact head (62) is fixedly mounted on an upper surface of the mounting piece (61), the mounting piece (61) is movably connected to a threaded piece (65) through a threaded groove (63), and the threaded piece (65) is fixedly connected to a cinder intercepting grille (66) through a water pipe (64).

2. The blowout preventing drill bit for coal seam drilling construction according to claim 1, wherein six groups of first grooves (2) are disposed on the outer wall of the drill bit (1), the six groups of first grooves (2) are arranged in a circumferential array along the outer wall of the drill bit (1), and a water outlet (3) is arranged on a left side surface of the drill bit (1) near a middle position; and a second groove (4) is arranged on an outer side of the water outlet (3).

3. The blowout preventing drill bit for coal seam drilling construction according to claim 2, wherein a left end of the connecting rod (501) is fixedly mounted on a right end of the drill bit (1), the first circlip spring (502) is fixedly mounted on an inner wall of the connecting rod (501) near a right end position, and the valve seat (503) is fixedly mounted on a left end of the first circlip spring (502); and a seal piece (510) is fixedly mounted on an outer wall of the valve seat (503), and an outer wall of the seal piece (510) abuts against the inner wall of the connecting rod (501).

4. The blowout preventing drill bit for coal seam drilling construction according to claim 3, wherein the second circlip spring (509) is fixedly mounted on an inner wall of the drill bit (1), an left end of the joint body (508) is fixedly mounted at a right end of the second circlip spring (509), and a left end of the spring (507) is fixedly mounted at a right end of the joint body (508); the left end of the spring (507) is fixedly connected to a left end of the valve core (505), the valve core (505) is slidably connected to an interior of the drill bit (1), and a right end of the valve core (505) is abutted against a left end of the valve seat (503); and the first sector-shaped water outlet hole (504) and the second sector-shaped water outlet hole (506) are mutually staggered by ninety degrees.

5. The blowout preventing drill bit for coal seam drilling construction according to claim 2, wherein the impact heads (62) are distributed in the circumferential array along a surface of the mounting piece (61), a lower end of the mounting piece (61) is fixedly mounted at an interior of the second groove (4), and the threaded groove (63) is disposed on an inner wall of the mounting piece (61).

6. The blowout preventing drill bit for coal seam drilling construction according to claim 5, wherein the threaded piece (65) is fixedly mounted on an outer wall of the water pipe (64), the threaded piece (65) are threadedly connected to the threaded groove (63), and the cinder intercepting grille (66) is fixedly mounted on an inner wall of the water pipe (64) near an upper end position.

7. The blowout preventing drill bit for coal seam drilling construction according to claim 2, wherein the water pressure regulating mechanism (7) comprises a first connecting pipe (71), a left end of the first connecting pipe (71) is fixedly mounted at a right end of the connecting rod (501), and a first slot (72) is disposed on an inner wall of a right end of the first connecting pipe (71); and a first plug pipe (73) is inserted at an interior of the first slot (72), and a water pressure regulating valve (74) is fixedly mounted at the right end of the first plug pipe (73).

8. The blowout preventing drill bit for coal seam drilling construction according to claim 7, wherein a second plug pipe (75) is fixedly mounted at the right end of the water pressure regulating valve (74), and the second plug pipe (75) is movably connected to a second connecting pipe (76) through a second slot (77).

9. The blowout preventing drill bit for coal seam drilling construction according to claim 2, wherein a monitoring mechanism (8) comprises a pressure sensor (81), a temperature sensor (82), a vibration sensor (83), a rotational speed sensor (84), a displacement sensor (85), and a gas concentration sensor (86); and the pressure sensor (81), the temperature sensor (82), the vibration sensor (83), the rotational speed sensor (84), the displacement sensor (85), and the gas concentration sensor are fixedly mounted at interiors of the six groups of first grooves (2).

REVENDEICATIONS

LU509231

1. Trépan anti-éruption pour le forage de veines de charbon, comprenant un trépan (1) et un mécanisme anti-éruption (5), dans lequel un mécanisme d'interception des cendres (6) est disposé sur le côté gauche du trépan (1), un mécanisme de régulation de la pression de l'eau (7) est disposé sur le côté droit du mécanisme anti-éruption (5), et un mécanisme de surveillance (8) est disposé sur une paroi extérieure du trépan (1) ;

le mécanisme anti-éruption (5) comprend une bielle (501), la bielle (501) est reliée de manière fixe à un siège de soupape (503) par l'intermédiaire d'un premier circlip (502), un premier trou de sortie d'eau en forme de secteur (504) est disposé à l'intérieur du siège de soupape (503), un ressort (507) est relié de manière mobile à travers un noyau de soupape (505), et un deuxième trou de sortie d'eau en forme de secteur (506) est disposé à l'intérieur du noyau de soupape (505) ; et le ressort (507) est relié de manière mobile à un second circlip (509) par l'intermédiaire d'un corps de joint (508) ; et

le mécanisme d'interception des cendres (6) comprend une pièce de montage (61), une tête d'impact (62) est montée de manière fixe sur une surface supérieure de la pièce de montage (61), la pièce de montage (61) est reliée de manière mobile à une pièce filetée (65) par l'intermédiaire d'une rainure filetée (63), et la pièce filetée (65) est reliée de manière fixe à une grille d'interception des cendres (66) par l'intermédiaire d'un tuyau d'eau (64).

2. Trépan anti-éruption pour le forage de veines de charbon selon la revendication 1, dans lequel six groupes de premières rainures (2) sont disposés sur la paroi extérieure du trépan (1), les six groupes de premières rainures (2) sont disposés dans un réseau circonférentiel le long de la paroi extérieure du trépan (1), et une sortie d'eau (3) est disposée sur une surface latérale gauche du trépan (1) près d'une position médiane ; et une deuxième rainure (4) est disposée sur un côté extérieur de la sortie d'eau (3).

3. Trépan anti-éruption pour le forage de veines de charbon selon la revendication 2, dans lequel une extrémité gauche de la bielle (501) est montée de manière fixe sur une extrémité droite du trépan (1), le premier ressort à circlips (502) est monté de manière fixe sur une paroi intérieure de la bielle (501) près d'une position d'extrémité droite, et le siège de soupape (503) est monté de manière fixe sur une extrémité gauche du premier ressort à circlips (502) ; et une pièce d'étanchéité (510) est montée de manière fixe sur

une paroi extérieure du siège de soupape (503), et une paroi extérieure de la pièce d'étanchéité (510) vient en butée contre la paroi intérieure de la bielle (501). LU509231

4. Trépan anti-éruption pour le forage de veines de charbon selon la revendication 3, dans lequel le second ressort à circlips (509) est monté de manière fixe sur une paroi intérieure du trépan (1), une extrémité gauche du corps de joint (508) est montée de manière fixe à une extrémité droite du second ressort à circlips (509), et une extrémité gauche du ressort (507) est montée de manière fixe à une extrémité droite du corps de joint (508) ; l'extrémité gauche du ressort (507) est reliée de manière fixe à l'extrémité gauche du noyau de soupape (505), le noyau de soupape (505) est relié de manière coulissante à l'intérieur du trépan (1), et l'extrémité droite du noyau de soupape (505) est en butée contre l'extrémité gauche du siège de soupape (503) ; et le premier trou de sortie d'eau en forme de secteur (504) et le deuxième trou de sortie d'eau en forme de secteur (506) sont mutuellement décalés de quatre-vingt-dix degrés.

5. Trépan anti-éruption pour le forage de veines de charbon selon la revendication 2, dans lequel les têtes d'impact (62) sont réparties dans le réseau circonférentiel le long d'une surface de la pièce de montage (61), une extrémité inférieure de la pièce de montage (61) est montée de manière fixe à l'intérieur de la deuxième rainure (4), et la rainure filetée (63) est disposée sur une paroi intérieure de la pièce de montage (61).

6. Trépan anti-éruption pour le forage de filons de charbon selon la revendication 5, dans lequel la pièce filetée (65) est montée de manière fixe sur une paroi extérieure de la conduite d'eau (64), la pièce filetée (65) est reliée de manière filetée à la rainure filetée (63), et la grille d'interception de cendres (66) est montée de manière fixe sur une paroi intérieure de la conduite d'eau (64) à proximité d'une position d'extrémité supérieure.

7. Trépan anti-éruption pour le forage de veines de charbon selon la revendication 2, dans lequel le mécanisme de régulation de la pression d'eau (7) comprend un premier tuyau de raccordement (71), une extrémité gauche du premier tuyau de raccordement (71) est montée de manière fixe à une extrémité droite de la tige de raccordement (501), et une première fente (72) est disposée sur une paroi intérieure d'une extrémité droite du premier tuyau de raccordement (71) ; un premier tuyau d'obturation (73) est inséré à l'intérieur de la première fente (72), et une vanne de régulation de la pression de l'eau (74) est montée de manière fixe à l'extrémité droite du premier tuyau d'obturation (73).

8. Trépan anti-éruption pour le forage de filons de charbon selon la revendication 7 ^{LU509231} dans lequel un second tube d'obturation (75) est monté de manière fixe à l'extrémité droite de la vanne de régulation de la pression d'eau (74), et le second tube d'obturation (75) est connecté de manière mobile à un second tube de raccordement (76) à travers une seconde fente (77).

9. Trépan anti-éruption pour le forage de filons de charbon selon la revendication 2, dans lequel un mécanisme de surveillance (8) comprend un capteur de pression (81), un capteur de température (82), un capteur de vibration (83), un capteur de vitesse de rotation (84), un capteur de déplacement (85), et un capteur de concentration de gaz (86) ; et le capteur de pression (81), le capteur de température (82), le capteur de vibration (83), le capteur de vitesse de rotation (84), le capteur de déplacement (85) et le capteur de concentration de gaz sont montés de manière fixe à l'intérieur des six groupes de premières rainures (2).

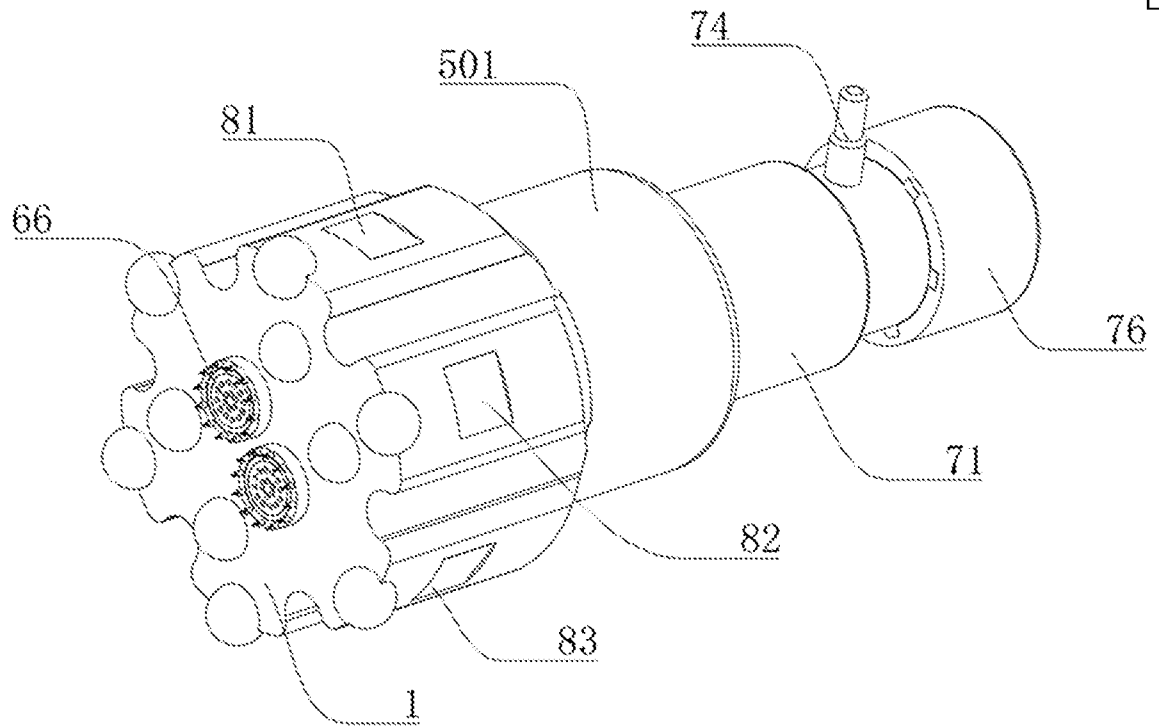

FIG. 1

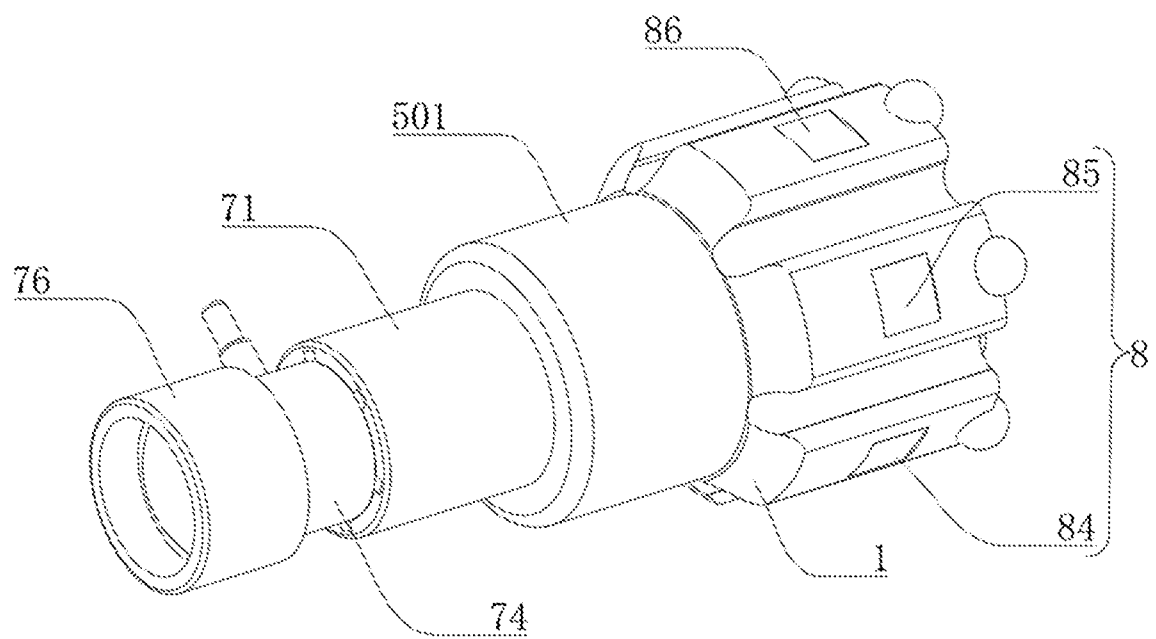

FIG. 2

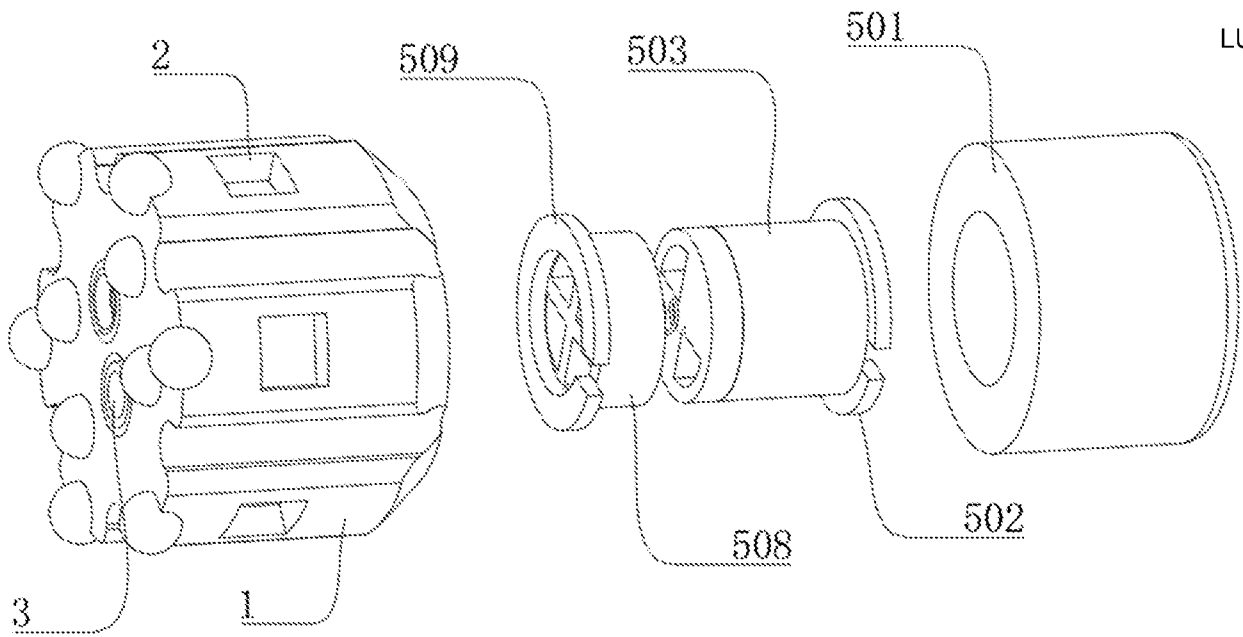

FIG. 3

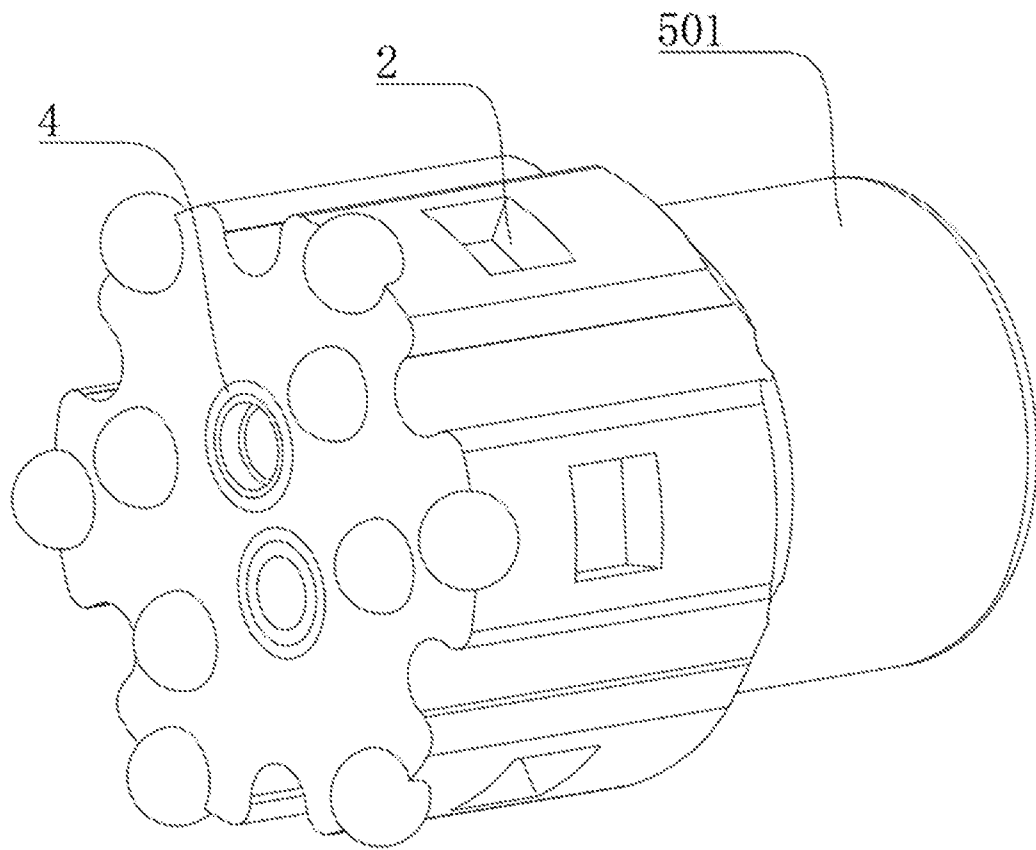

FIG. 4

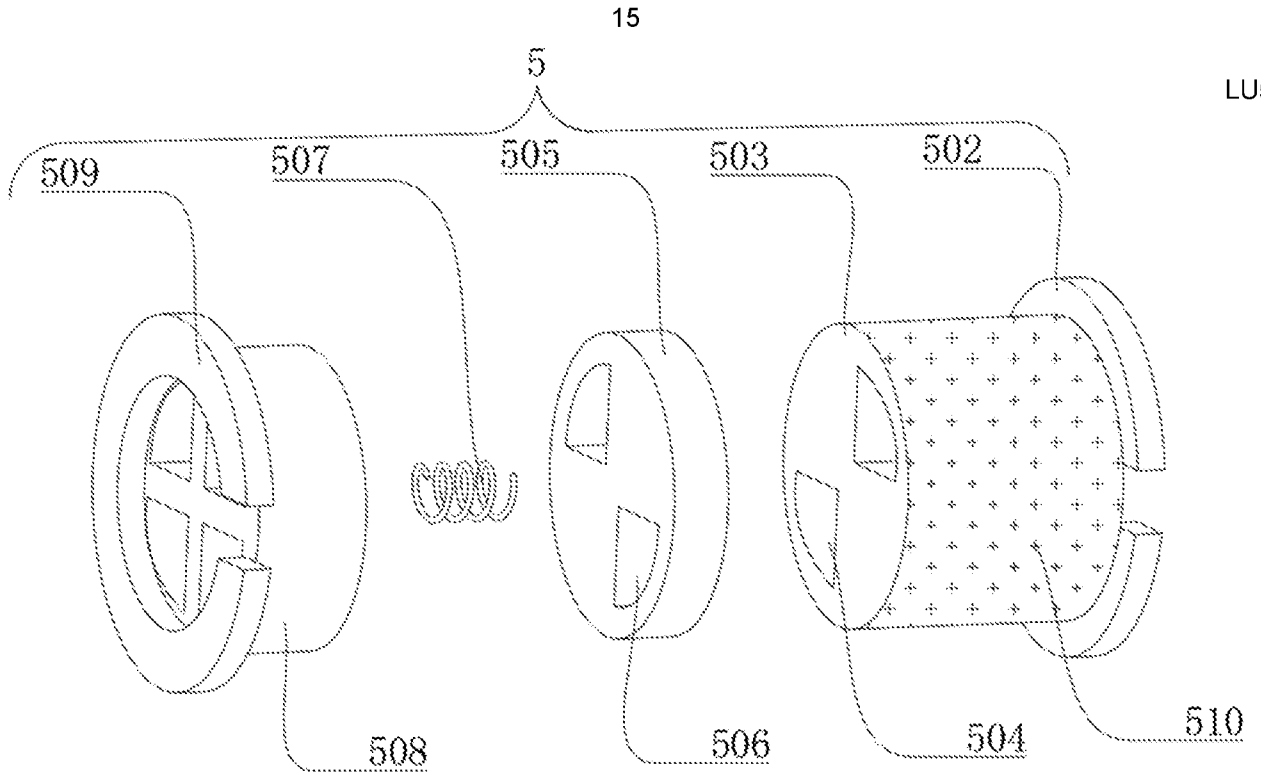

FIG. 5

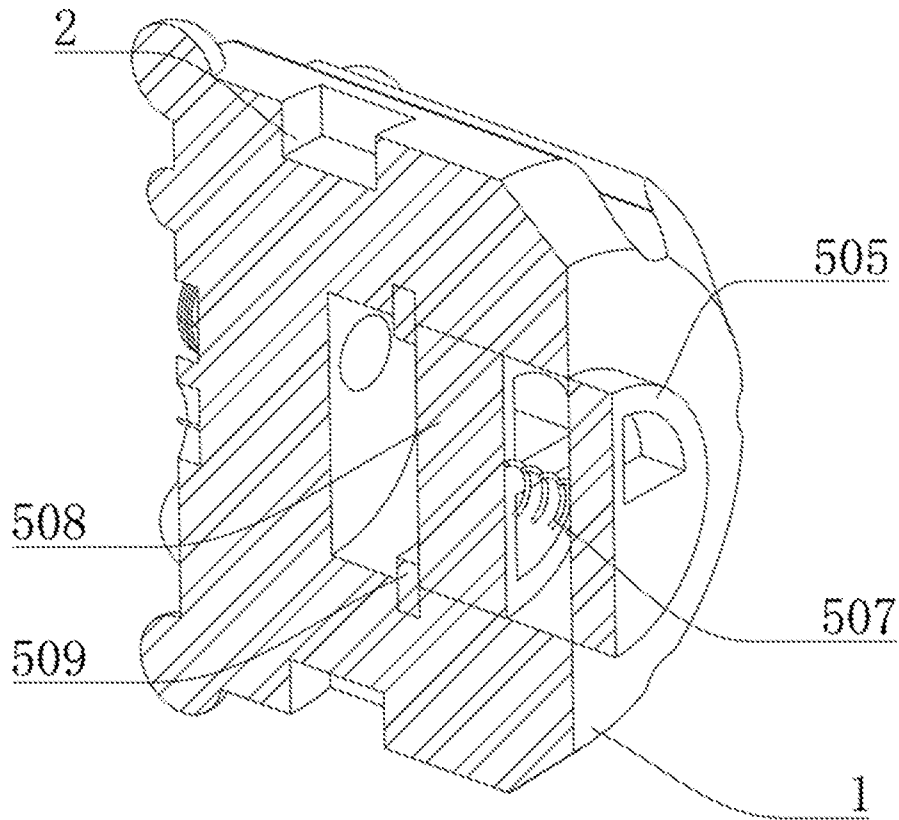

FIG. 6

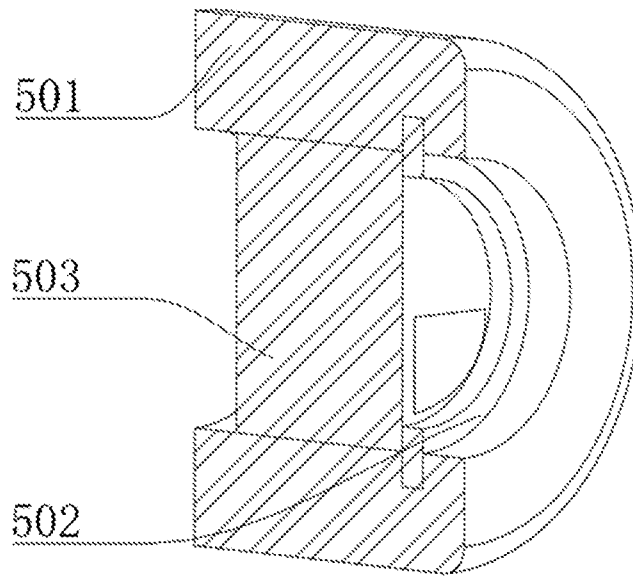

FIG. 7

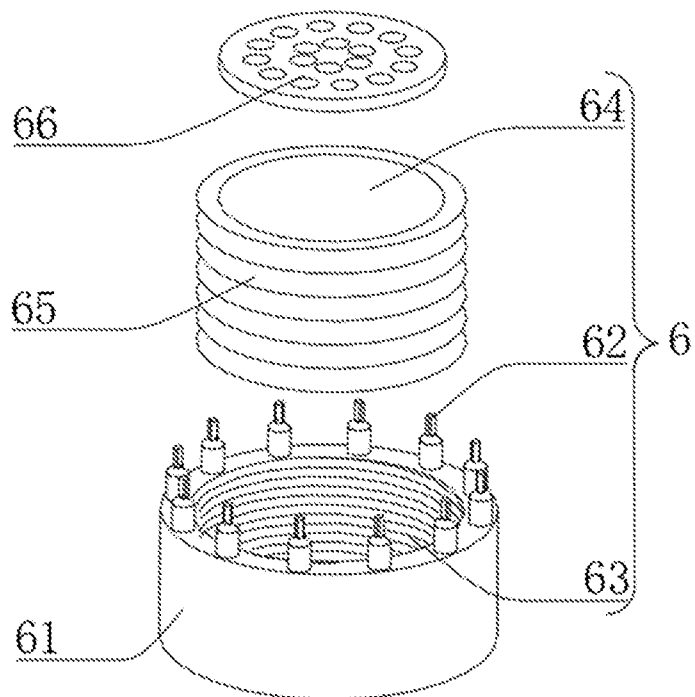

FIG. 8

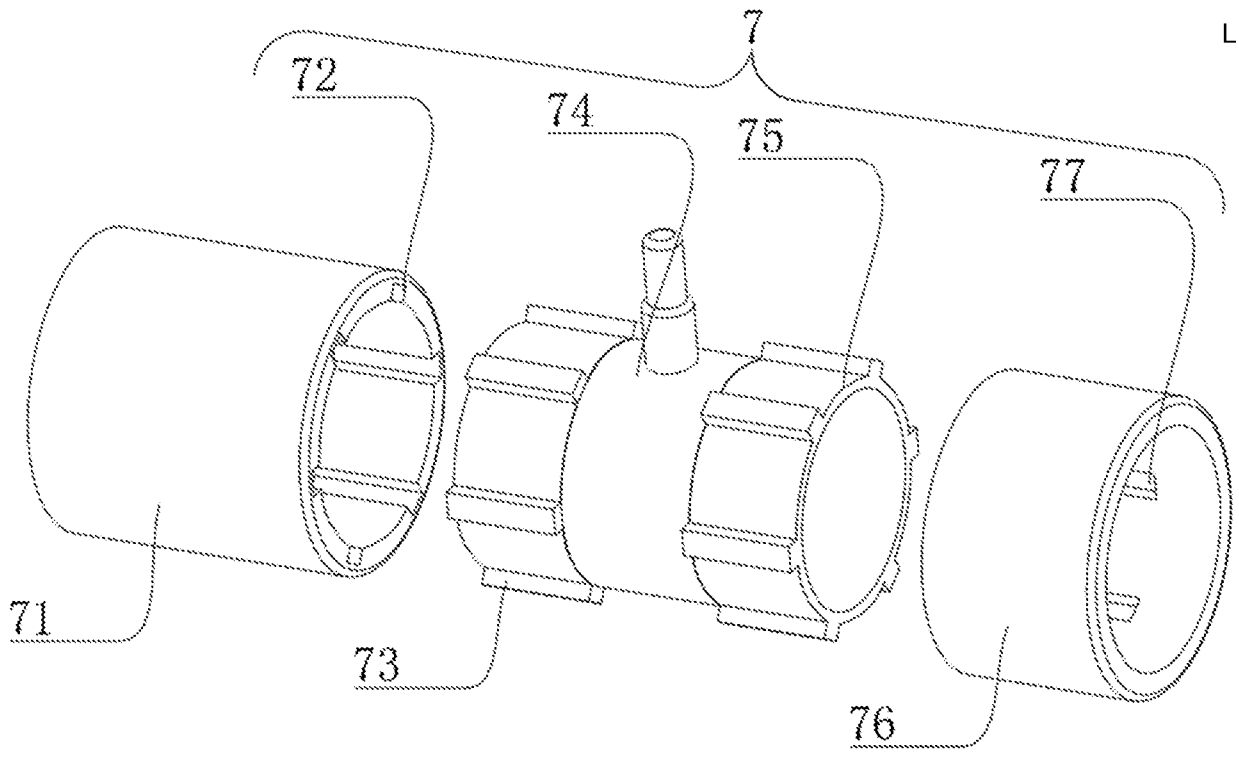

FIG. 9