

Dec. 24, 1929.

C. B. GILMORE

1,740,586

WINDOW ATTACHMENT

Filed June 24, 1927

2 Sheets-Sheet 1

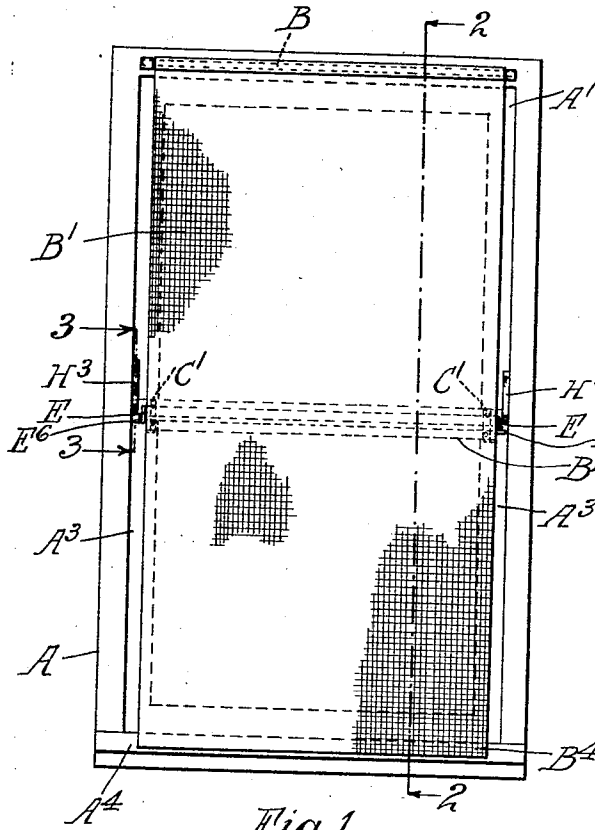

Fig. 1

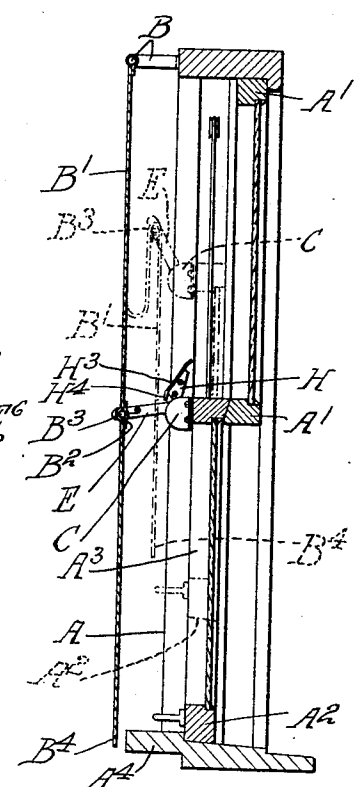

Fig. 2

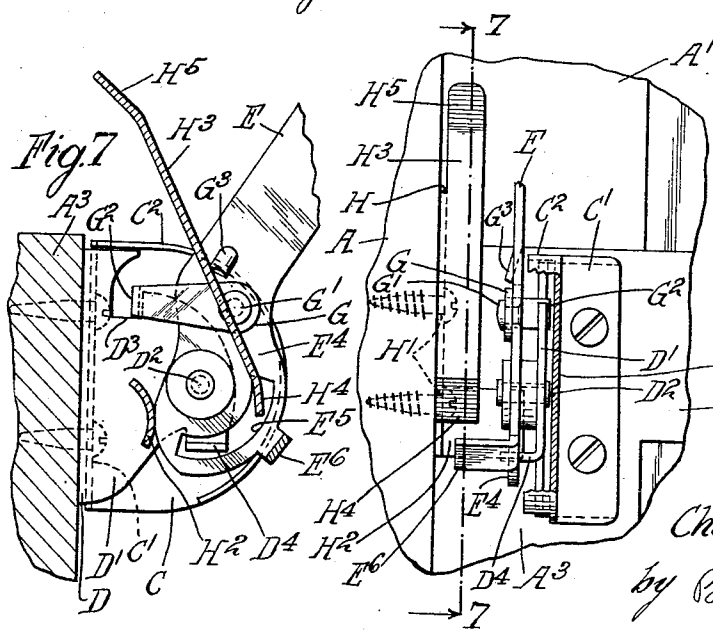

Fig. 6

Fig. 7

Inventor
Charles B. Gilmore
by Parker & Carter
Attorneys.

Dec. 24, 1929.

C. B. GILMORE

1,740,586

WINDOW ATTACHMENT

Filed June 24, 1927

2 Sheets-Sheet 2

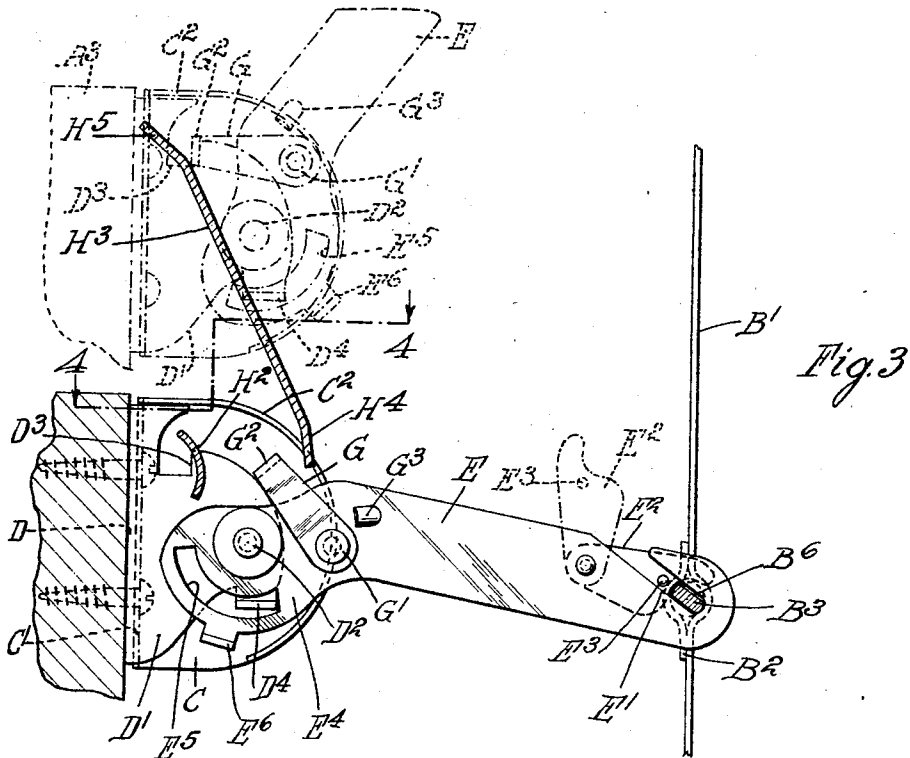

Fig. 3

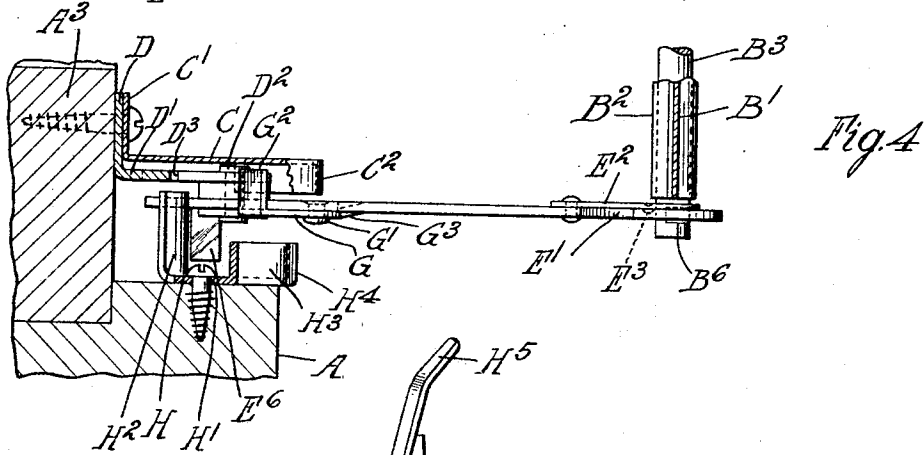

Fig. 4

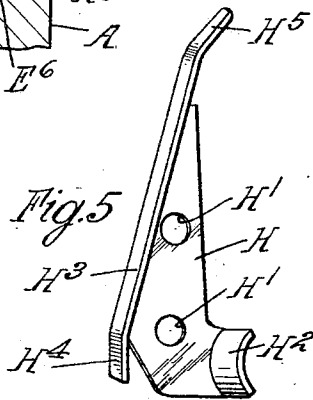

Fig. 5

Inventor
Charles B. Gilmore
by Parker & Carter
Attorneys.

UNITED STATES PATENT OFFICE

CHARLES B. GILMORE, OF CHICAGO, ILLINOIS, ASSIGNOR TO CHICAGO FORGING & MANUFACTURING COMPANY, OF CHICAGO, ILLINOIS, A CORPORATION OF ILLINOIS

WINDOW ATTACHMENT

Application filed June 24, 1927. Serial No. 201,114.

My invention relates to a curtain raising and lowering device and has for its principal purpose the provision of a device for raising and lowering curtains in response to the raising and lowering of a window sash. One object of my invention is to provide a simple and efficient mechanism for accomplishing the above function, which shall be cheap, simple to manufacture, sturdy in construction and efficient in use. Another object is the elimination so far as possible, of guiding devices on the window frame. Other objects will appear from time to time in the course of the specification and claims.

I illustrate my invention more or less diagrammatically in the accompanying drawings, wherein—

Figure 1 is a front elevation of a window of my device in position;

Figure 2 is a vertical section on the line 2—2 of Figure 1;

Figure 3 is a section on the line 3—3 of Figure 1;

Figure 4 is a section on the line 4—4 of Figure 3;

Figure 5 is a perspective view of a detail;

Figure 6 is an enlarged front elevation of the device with parts in different positions and partly broken away; and

Figure 7 is a section on the line 7—7 of Figure 6.

Like parts are indicated by like symbols throughout the specification and drawings.

Referring to the drawings, A indicates any suitable window frame having the upper sash A¹ and the lower sash A² with the side members A³.

B indicates any suitable curtain rod or supporting structure from which depends the curtain B¹. The curtain is herein shown as having a hem or doubled portion intermediate top and bottom as at B², through which passes the rod B³ the ends of which are secured to the lifting mechanism below described. It will be observed that the lower edge B⁴ of the curtain normally depends to or beneath the window sill A⁴.

Mounted at the upper corners of the sash side members A³ are the outwardly projecting shields C herein shown as including a gen-

erally semi-circular body provided with the laterally extended flanges C¹ which may be screwed or bolted to the window frame. The body C is further provided with a flange C² extending in the opposite direction.

Contained within the housing or shield thus formed is a support member including a flange D which underlies the flange C¹ above described and is held to the sash frame by the same securing means. Outwardly projecting from the sash is the support portion D¹ through which passes a pivoted member D². D³ indicates a stop notch on the upper side of said support and D⁴ a laterally extending stop lug on the lower side thereof.

Mounted upon the pivot D² is a lever E at the outer end of which is a notch E¹ in which is seated the end of the rod B³, which may be squared or flattened or notched as at B⁶ to penetrate said notch. E² is a pivoted locking member adapted to close said notch, and E³ is a stud or projection thereon, adapted to engage the notch E¹ to hold the member E² against unintended movement. The pivot end of the lever is enlarged as at E⁴ and the enlargement is provided with an arcuate slot E⁵ through which passes the previously described stop lug D⁴. E⁶ is a laterally projecting lug formed beyond the arcuate slot E⁵ at the pivot end of the lever.

Mounted on the lever is the dog G pivoted thereto as at G¹ and provided with a laterally extending lug G² adapted to engage the stop slot or notch D³, above described. G³ is an upset portion on the lever adapted to limit the rearward movement of the dog G.

Mounted on the window frame, adjacent the normal position of the above described mechanism when the sash is lowered is the member shown in detail in Figure 5.

H indicates a flat body portion thereof provided with the screw or bolt holes H¹, whereby it may be attached to the window frame. Projecting from the lower inner side thereof is the arcuate lug H² and projecting outwardly from the opposite side thereof is the rectilinear lug H³ provided with the inclined end portions H⁴ H⁵, said lug and its end portions being inclined across the vertical path of movement of the sash.

It will be realized that whereas I have described and shown a practical and operative device, nevertheless many changes might be made in the size, shape, number and disposition of parts without departing from the spirit of my invention. I therefore wish my drawings and description to be taken as in a broad sense illustrative and diagrammatic rather than as limiting me to my specific showing.

The use and operation of my invention are as follows:

When the window is closed as shown in Figures 1 and 2, the curtain B¹ hangs in relaxed position, the parts being so proportioned that the rod B³ does not lift or fold the curtain at all. At such time the edge of the curtain hangs below the edge of the window sill, when the proportion of parts is as herein shown. When the sash is lifted the inner ends of the levers E engage the arcuate cams H² and the levers are therefore rotated about their pivots to the position shown in Figure 7. When they reach such position the dogs G drop into the slots D³ and prevent the levers from rotating back into horizontal position. Unless tampered with the levers will remain in raised position until the sash is again lowered, and the curtain is folded and raised, as shown in dotted line in Figure 2. The result is to lift the lower edge of the curtain above the lower edge of the sash. This prevents the curtain from blowing out of the window and prevents it from being moistened by rain or dirtied by inblowing dust.

When the sash is again lowered the dog G is engaged and lifted by the arcuate lug H² and the lever is permitted to rotate into the lowered position shown in Figure 3. The lug D⁴ in the arcuate slot E⁵ limits the movement of the lever, the lever not being permitted to rotate, in the form herein shown, below a substantially horizontal position.

It is important that when the curtain descends both levers shall rotate in unison. If for any reason one of the levers is rotated into lowered position while the sash is raised, its lug E⁶ engages the inclined lug H³ of the member H and the lever is rotated into a raised position just before the sash reaches its lower position. Immediately after the lever has been raised by such contact with the flange H³ the dog G is engaged by the lug D³ and both levers rotate in unison to the lower position.

I claim:

1. In an apparatus including a frame, a sash movable in the frame, and curtain raising means associated with the sash, the combination with the curtain raising means of means carried by the sash to retain the curtain raising means in raised position.

2. In an apparatus including a frame, a sash movable in the frame, and curtain rais-

ing means associated with the sash, the combination with the curtain raising means of means carried by the sash to retain the curtain raising means in raised position, and means for releasing said curtain raising element upon the lowering of the sash.

3. In an apparatus including a frame, a sash movable in the frame, curtain raising means associated with the sash and actuating means for said curtain raising means, mounted on the window frame, the combination with the curtain raising means of means carried by the sash to retain the curtain raising means in raised position after the curtain raising means have been actuated.

4. In an apparatus including a frame, a sash movable in the frame, curtain raising means associated with the sash and actuating means for said curtain raising means, mounted on the window frame, the combination with the curtain raising means of means carried by the sash to retain the curtain raising means in raised position after the curtain raising means have been actuated, and means for releasing said curtain raising element upon the lowering of the sash.

5. In an apparatus including a frame, a sash movable on the frame and a curtain raising lever pivoted to the sash, the combination with the curtain raising lever of means carried by the sash to retain the lever in raised position, said means including a stop element mounted upon the sash, and a stop engaging member associated with the lever.

6. In an apparatus including a frame, a sash movable in the frame, and a curtain raising element in pivotal relation with the sash, the combination with the curtain raising element of means carried by the sash for retaining it in raised position, and means adapted, when the retaining element becomes disengaged, to raise said curtain raising element upon downward movement of the sash.

7. In an apparatus including a frame, a sash movable in the frame and curtain raising means associated with the sash, the combination with the curtain raising means of means carried by the sash for retaining the curtain raising means in raised position, said retaining means including a dog pivoted to the curtain raising means.

8. In an apparatus including a frame, a sash movable in the frame and curtain raising means associated with the sash, the combination with the curtain raising means of means carried by the sash for retaining the curtain raising means in raised position, said retaining means including a dog pivoted to the curtain raising means, and means for disengaging said dog in response to downward movement of the sash.

Signed at Chicago, county of Cook and State of Illinois, this 20th day of June, 1927.