



(12) **United States Patent**  
**Hwang et al.**

(10) **Patent No.:** **US 9,715,870 B2**  
(45) **Date of Patent:** **Jul. 25, 2017**

(54) **COGNITIVE MUSIC ENGINE USING UNSUPERVISED LEARNING**

5,308,915 A \* 5/1994 Ohya ..... G10H 7/00  
706/17  
5,883,326 A \* 3/1999 Goodman ..... G10H 1/0025  
84/634  
6,051,770 A \* 4/2000 Milburn ..... G10H 1/00  
84/611  
7,531,735 B2 5/2009 Koike  
7,716,572 B2 5/2010 Beauregard et al.  
7,842,874 B2 11/2010 Jehan  
(Continued)

(71) Applicant: **International Business Machines Corporation**, Armonk, NY (US)

(72) Inventors: **Inseok Hwang**, Austin, TX (US); **Jente B Kuang**, Austin, TX (US); **Janani Mukundan**, Austin, TX (US)

(73) Assignee: **International Business Machines Corporation**, Armonk, NY (US)

**OTHER PUBLICATIONS**

(\* ) Notice: Subject to any disclaimer, the term of this patent is extended or adjusted under 35 U.S.C. 154(b) by 0 days.

Hu et al.; "A Probabilistic Topic Model for Unsupervised Learning of Musical Key-Profiles", 10th International Society for Music Information Retrieval Conference On, ISMIR 2009, pp. 441-446.  
(Continued)

(21) Appl. No.: **14/880,372**

(22) Filed: **Oct. 12, 2015**

*Primary Examiner* — Christopher Uhler  
(74) *Attorney, Agent, or Firm* — Jeffrey S LaBaw; William Stock

(65) **Prior Publication Data**

US 2017/0103740 A1 Apr. 13, 2017

(51) **Int. Cl.**  
**G10H 1/00** (2006.01)  
**G06N 3/08** (2006.01)

(57) **ABSTRACT**

(52) **U.S. Cl.**  
CPC ..... **G10H 1/0025** (2013.01); **G06N 3/088** (2013.01); **G10H 2210/081** (2013.01); **G10H 2210/115** (2013.01); **G10H 2250/311** (2013.01)

A method for generating a musical composition based on user input is described. A first set of musical characteristics is extracted from a first input musical piece. The first set of music characteristics is prepared as an input vector into an unsupervised neural net comprised of a plurality of computing layers by perturbing the first set of musical characteristics according to a user intent expressed in the user input to create a perturbed vector. The perturbed vector is input into the first set of nodes of the unsupervised neural net. The unsupervised neural net is operated to calculate an output vector from a highest set of nodes. The output vector is used to create an output musical piece.

(58) **Field of Classification Search**  
USPC ..... 84/609  
See application file for complete search history.

(56) **References Cited**

**U.S. PATENT DOCUMENTS**

5,138,924 A \* 8/1992 Ohya ..... G10H 7/00  
706/17  
5,138,928 A \* 8/1992 Nakajima ..... G10H 1/40  
706/18

**17 Claims, 9 Drawing Sheets**

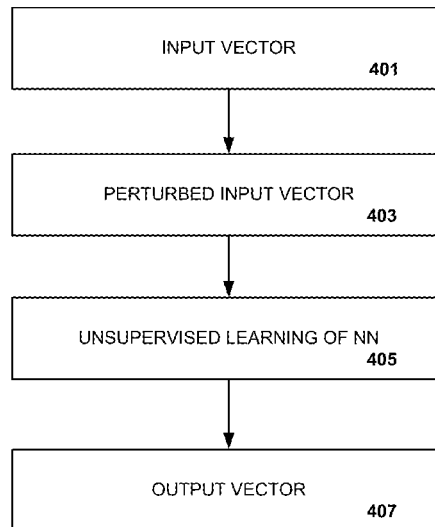

(56)

**References Cited**

U.S. PATENT DOCUMENTS

8,035,020	B2	10/2011	Taub et al.	
8,278,545	B2	10/2012	Hamanaka	
8,370,277	B2	2/2013	Goto et al.	
8,519,249	B2	8/2013	Alcalde et al.	
9,076,423	B2	7/2015	Matusiak	
9,099,066	B2	8/2015	Welch	
9,536,509	B2*	1/2017	Esparza .....	G10H 3/143
2007/0131095	A1	6/2007	Park et al.	
2007/0280270	A1*	12/2007	Laine .....	G06N 3/02 370/400
2009/0272252	A1	11/2009	Ladyjensky	
2014/0000440	A1	1/2014	Georges et al.	

OTHER PUBLICATIONS

Lee et al.; "Unsupervised Feature Learning for Audio Classification Using Convolutional Deep Belief Networks", Advances in Neural Information Processing System, 2009, pp. 1096-1104.

Gkiokas et al.; "Deploying Deep Belief Nets for Content Based Audio Music Similarity", Information, Intelligence, Systems and Applications (IISA), 2014 The 5th IEEE International Conference On, Jul. 7-9, 2014, pp. 180-185.

Correa et al.: "Neural Network Based Systems for Computer-Aided Musical Composition: Supervised x Unsupervised Learning" Jan. 2008, Conference paper. SAC '08, Mar. 16-20, 2008, pp. 1738-1742.

Bickerman et. al. "Learning to Create Jazz Melodies Using Deep Belief Nets" Jan. 2010, Proceedings of the International Conference on Computational Creativity, pp. 228-237.

Web site "WolframTones: About Wolfram Tones" found at <http://tones.wolfram.com/about/>, Sep. 2015, PDF provided.

Chan "Automated Composer of Style Sensitive Music", Proceedings of the Second Australian Undergraduate Students' Computing Conference, 2004.

\* cited by examiner

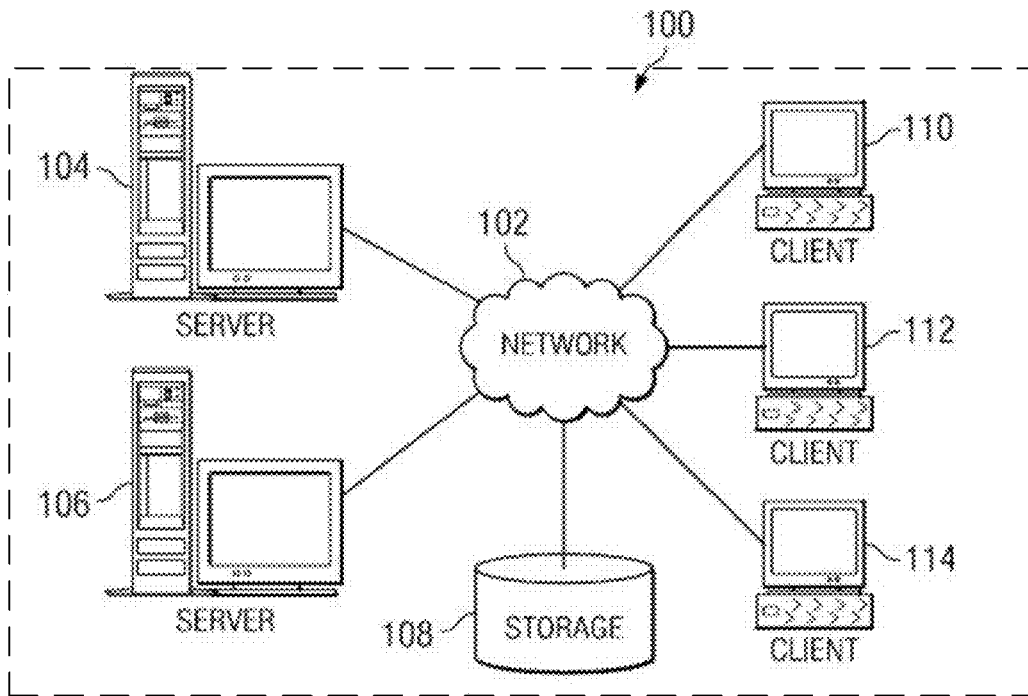

FIG. 1

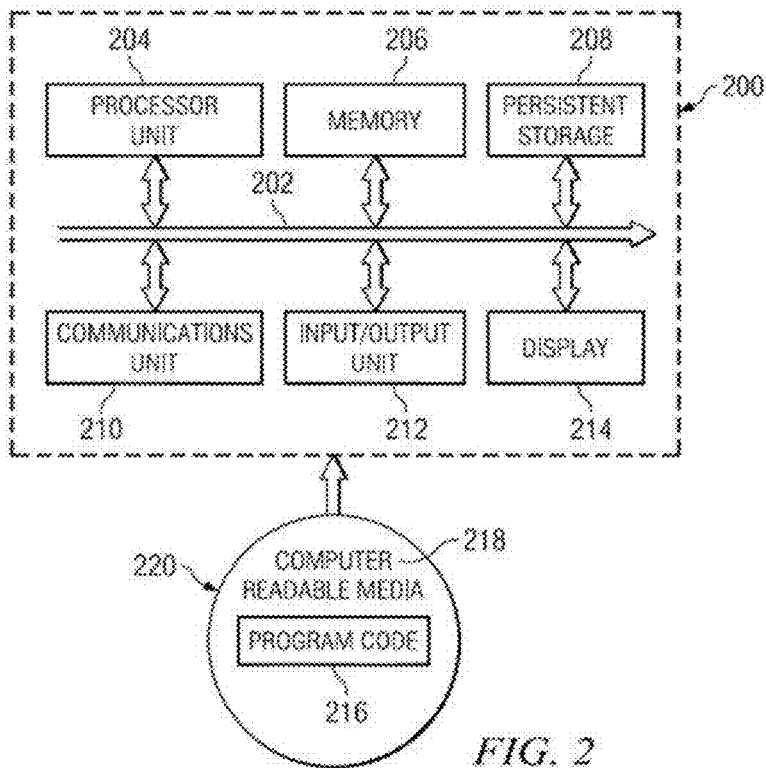

FIG. 2

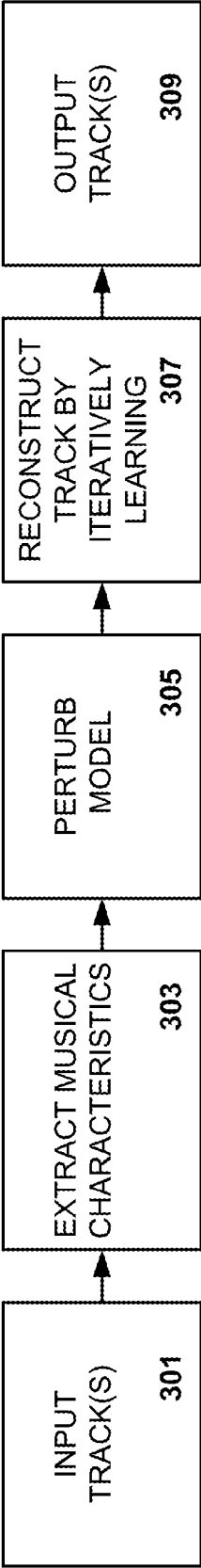

FIG. 3

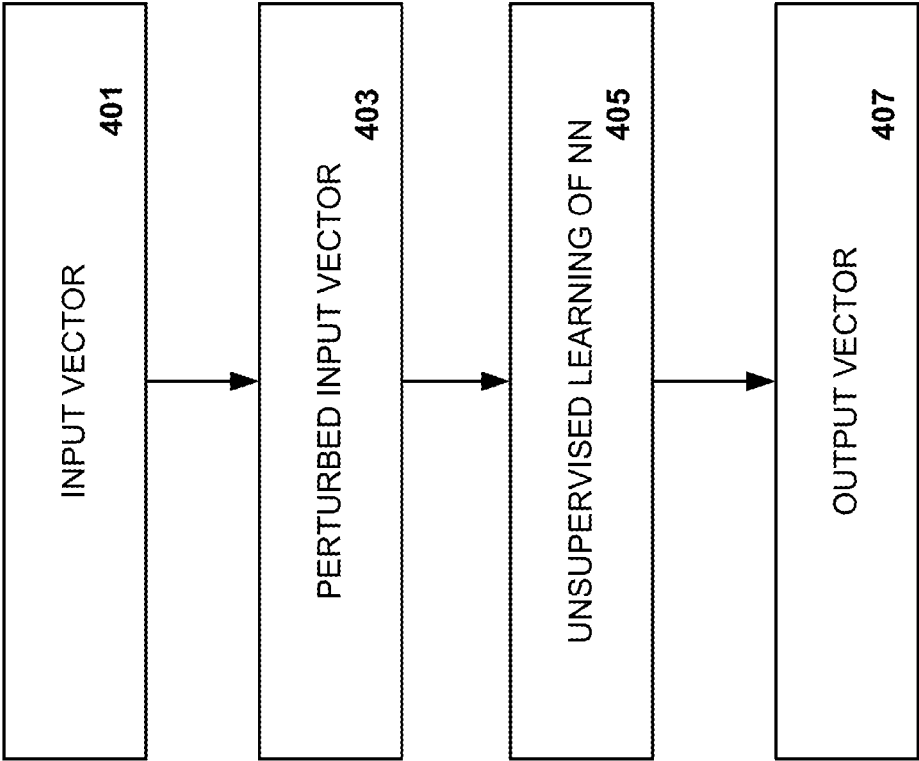

FIG. 4

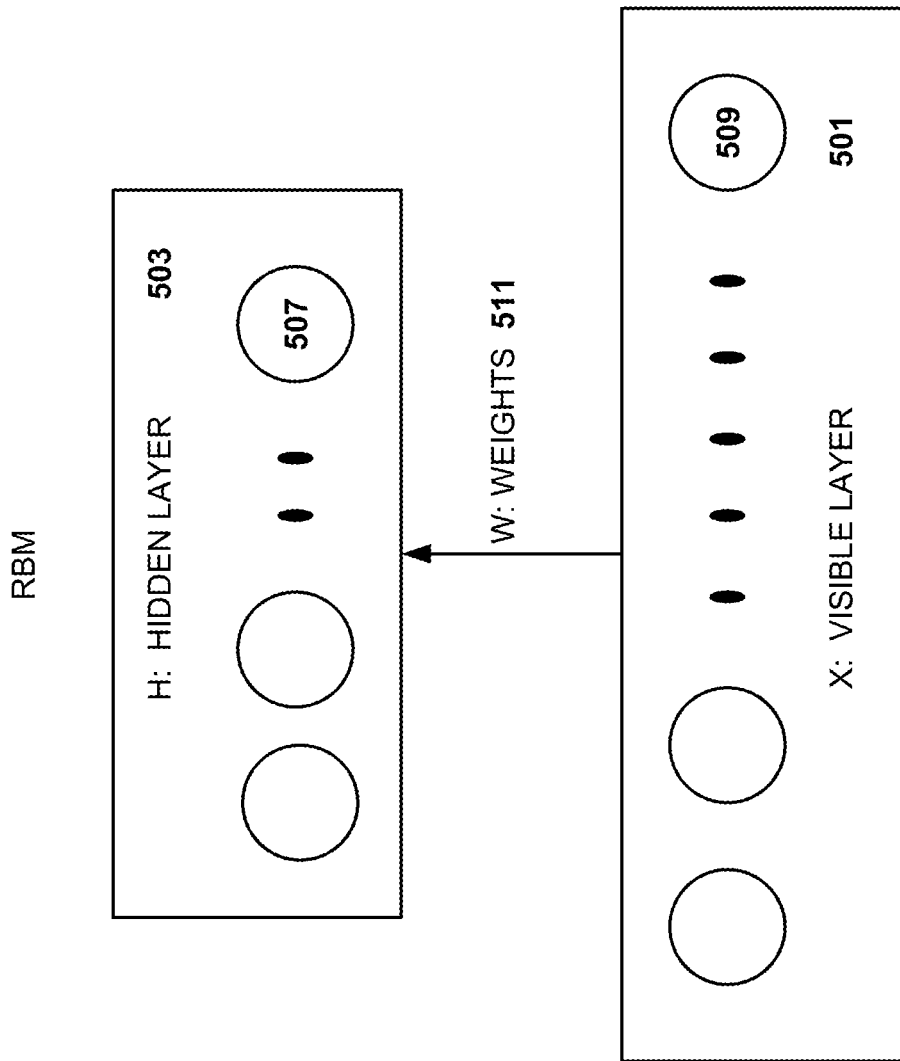

FIG. 5

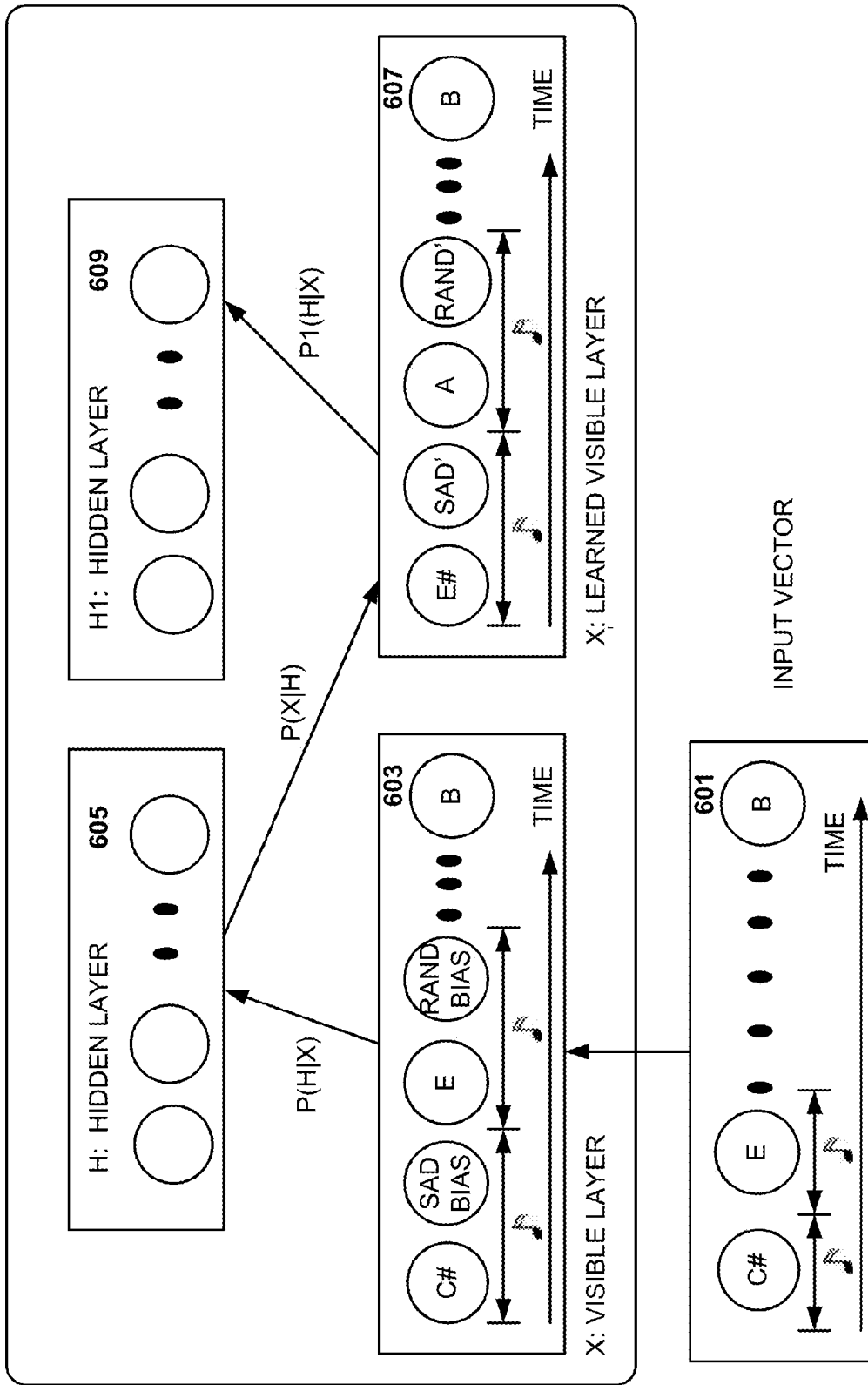

FIG. 6

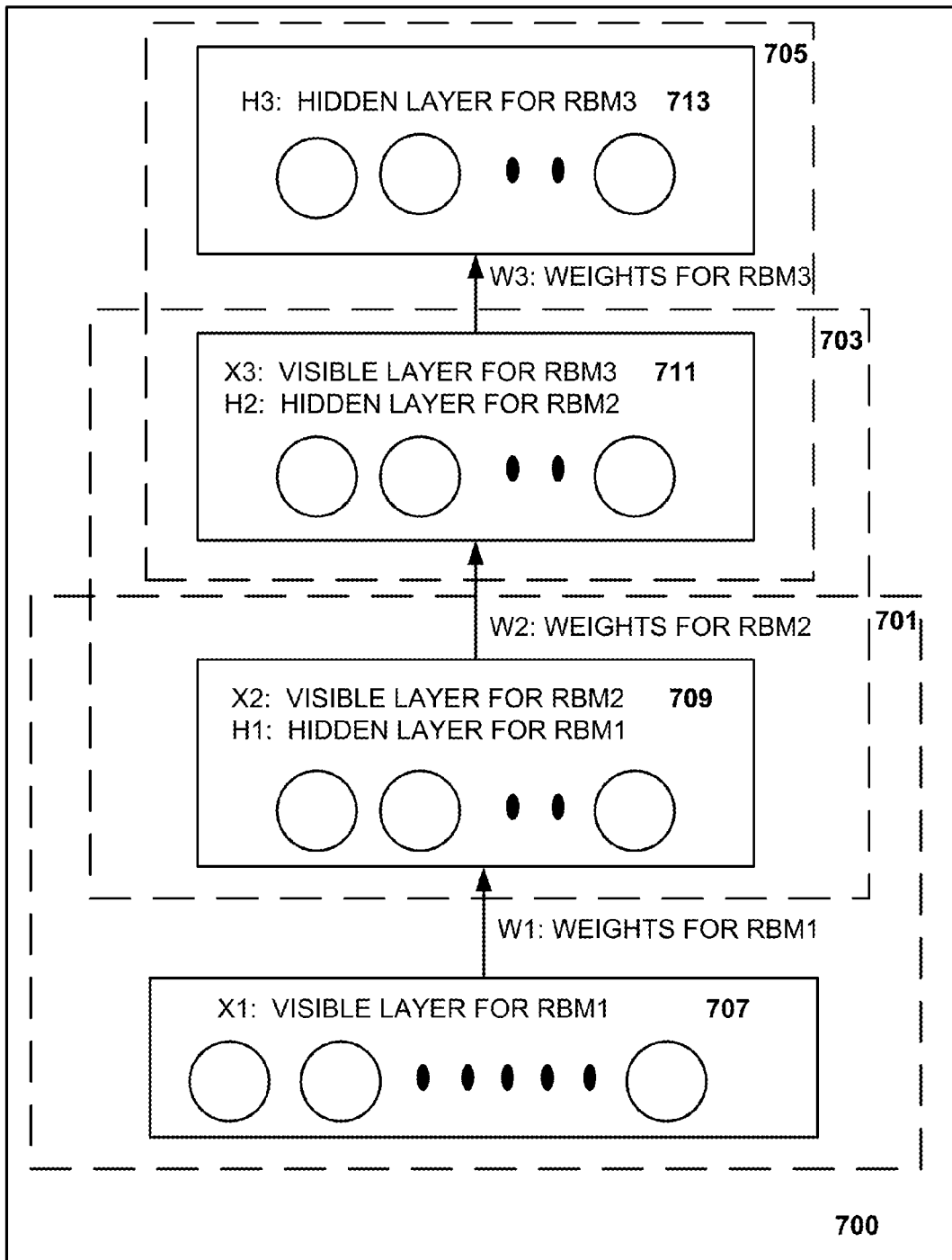

FIG. 7

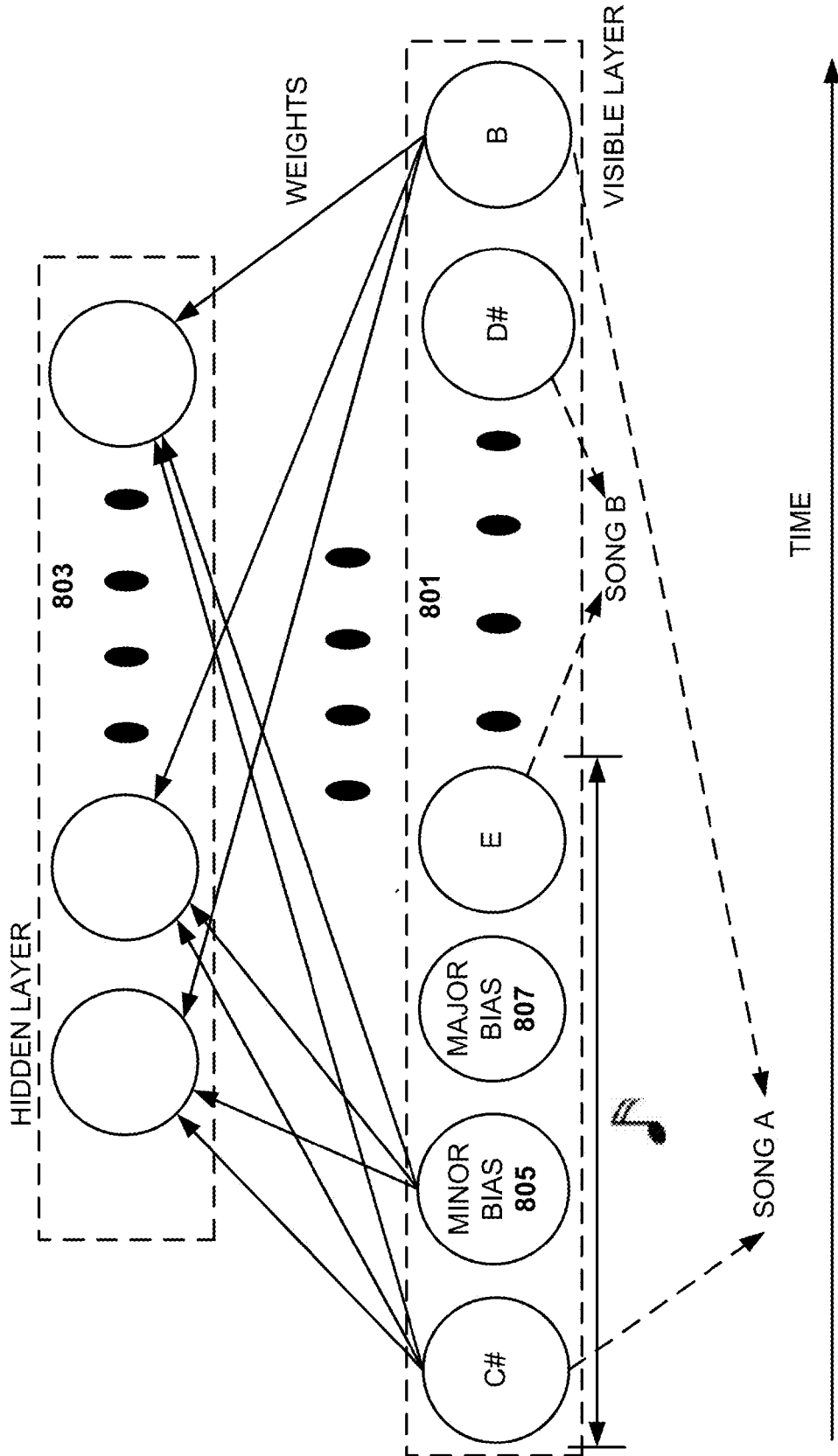

FIG. 8

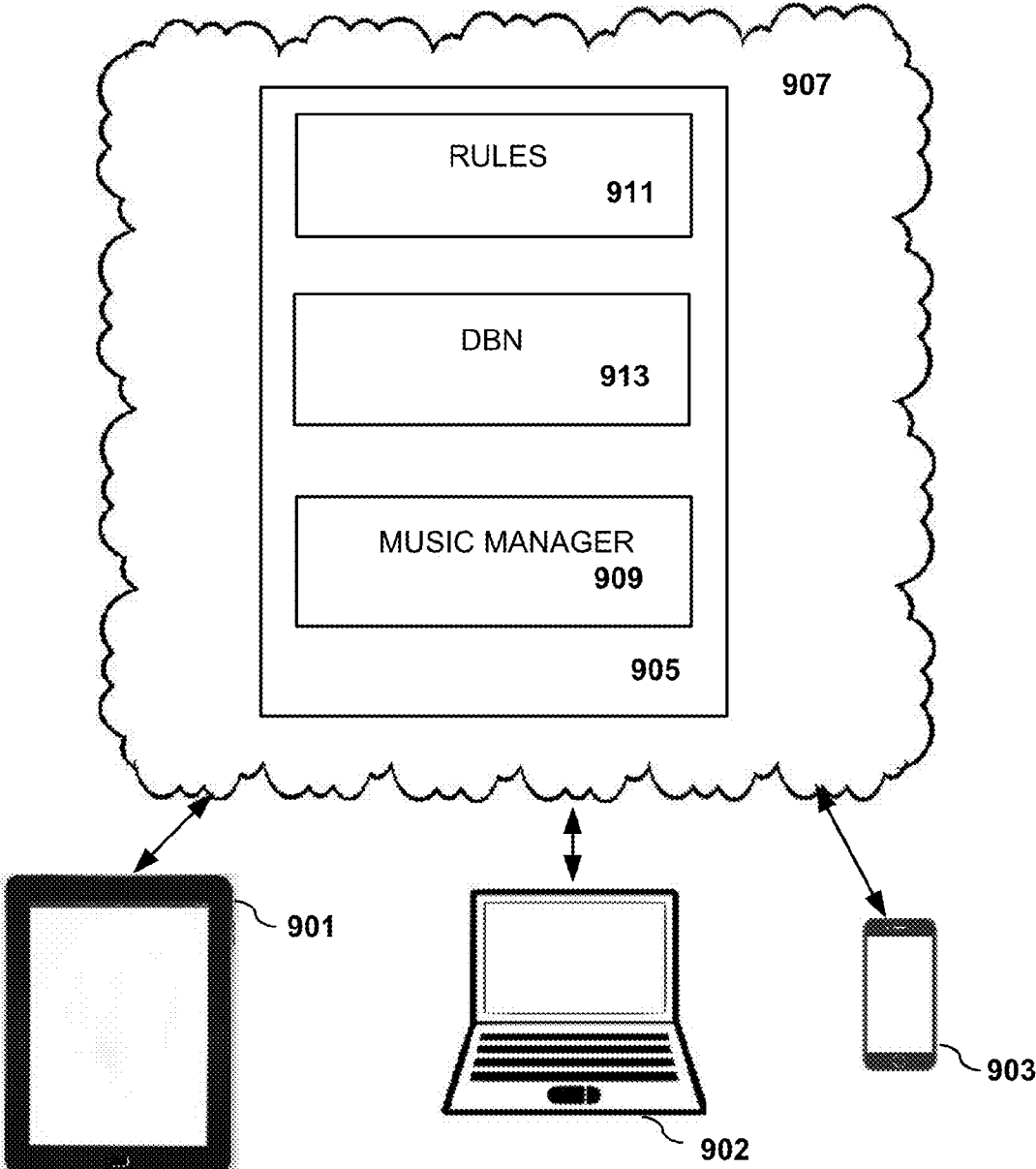

FIG.9

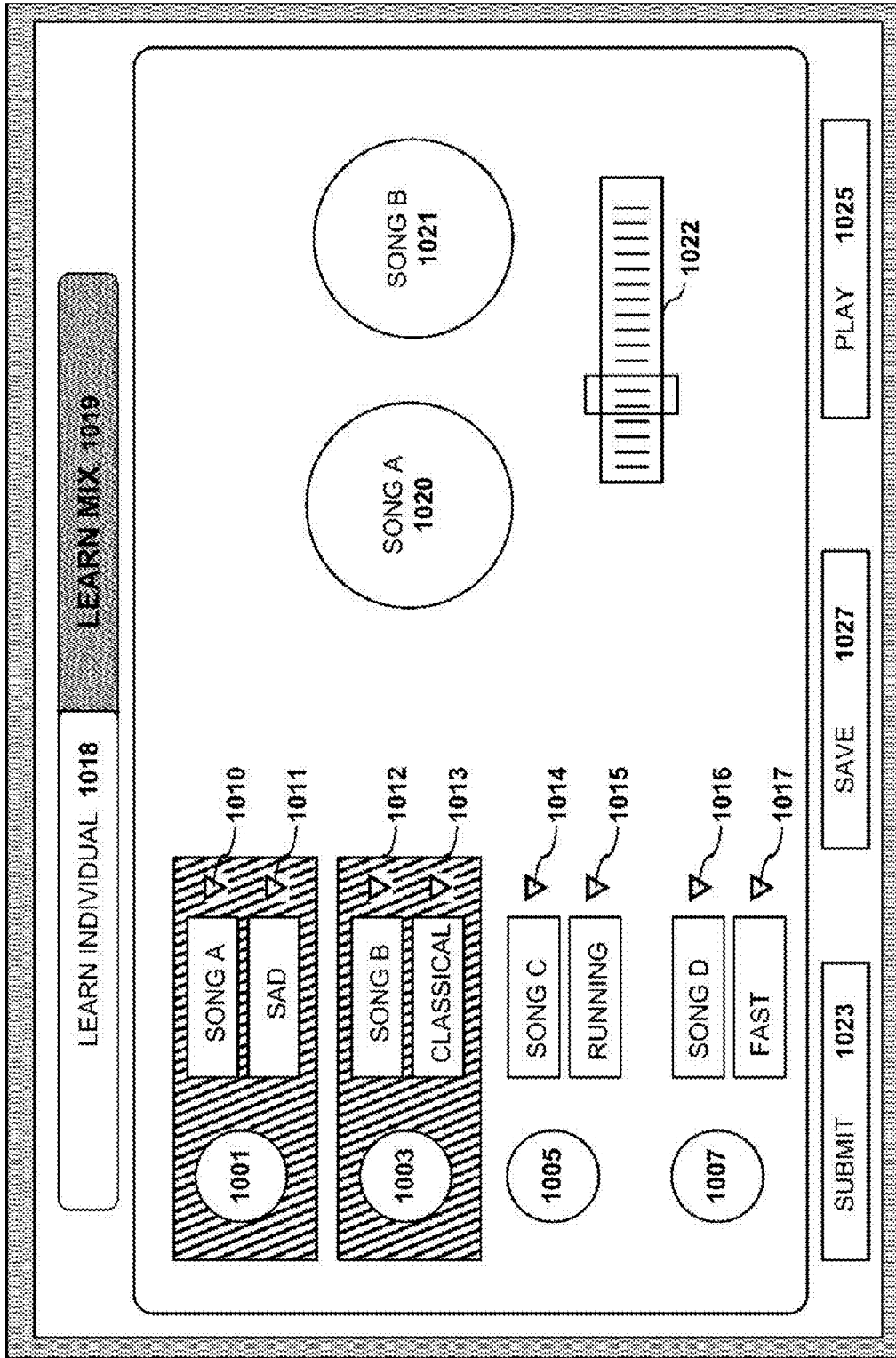

FIG. 10

## COGNITIVE MUSIC ENGINE USING UNSUPERVISED LEARNING

### BACKGROUND

#### Technical Field

This disclosure relates generally to the field of automated music analysis. More particularly, it relates to using unsupervised learning of musical pieces and computer creation of music based on the unsupervised learning.

#### Background of the Related Art

Computer aided musical composition is not new. There have been efforts dating from the 1950s using Markov chains to generate music using computers. There has been much work since that time. Neural networks have been used in more recent work to learn musical features in human written music as part of the process by which the computer learns to write music. During the learning, the neural networks have operated in either a supervised or an unsupervised mode. In a supervised mode, the inputs and outputs are controlled by a supervising human user who guides the computer to desired outputs. In an unsupervised mode, the computer does not have human guidance. The computer learns the patterns and features of the music, and organizes its learning into a form which can be used to generate music.

While efforts to provide computer aided musical composition have been many, the actual musical output has been mixed in comparison to music written by a human composer. Further, though the computer output has rarely matched the musical works of a skilled human composer, the effort on the part of highly skilled and intelligent computer scientists has been great. The training needed both to produce skilled computer scientists in the first place, and then for these skilled individuals to prepare the computer aided music systems to produce music in terms of time is considerable. Many systems require a volume of preexisting music data to analyze as well as a detailed set of rules concerning music theory. Typically, the inputs and desired output of these systems has been expressed in non-musical and non-intuitive forms, making them incomprehensible to a layman. Despite over sixty years of effort, current methods have fallen short.

It would be highly desirable to provide computer aided music composition which is accessible to an untrained, non-technical, non-musician, that is, an average person, which provides real time results.

### BRIEF SUMMARY

According to this disclosure, a method for generating a musical composition based on user input is described. Responsive to user input, a first set of musical characteristics is extracted from a first input musical piece. The first set of music characteristics is used as an input vector into a set of nodes in a first visual layer of a Deep Belief Network (DBN) comprised of a plurality of computing layers. The first set of musical characteristics is perturbed according to a user intent expressed in the user input to create a perturbed vector in the first set of nodes. The DBN is operated to calculate an output vector from a higher level hidden layer in the DBN. The output vector is used to create an output musical piece.

The foregoing has outlined some of the more pertinent features of the subject matter. These features should be construed to be merely illustrative. Many other beneficial

results can be attained by applying the disclosed subject matter in a different manner or by modifying the subject matter as will be described.

### BRIEF DESCRIPTION OF THE DRAWINGS

For a more complete understanding of the present invention and the advantages thereof, reference is now made to the following descriptions taken in conjunction with the accompanying drawings, in which:

FIG. 1 depicts an exemplary block diagram of a distributed data processing environment in which exemplary aspects of the illustrative embodiments may be implemented;

FIG. 2 is an exemplary block diagram of a data processing system in which exemplary aspects of the illustrative embodiments may be implemented;

FIG. 3 is a high level flow diagram of a preferred embodiment of the invention;

FIG. 4 is a high level flow diagram of the transformation of a vector including musical information according to the present invention;

FIG. 5 depicts a general Restricted Boltzmann Machine (RBM) which can be used in the present invention;

FIG. 6 depicts the operation of an RBM according to one embodiment of the present invention;

FIG. 7 depicts the operation of a Deep Belief Network (DBN) according to another embodiment of the present invention;

FIG. 8 depicts the configuration of an RBM according to another embodiment of the invention;

FIG. 9 illustrates a cloud service embodiment of the invention providing music composition services to a plurality of users; and

FIG. 10 shows a graphical user interface for an embodiment of the invention for a tablet computer.

### DETAILED DESCRIPTION OF AN ILLUSTRATIVE EMBODIMENT

With reference now to the drawings and in particular with reference to FIGS. 1-2, exemplary diagrams of data processing environments are provided in which illustrative embodiments of the disclosure may be implemented. It should be appreciated that FIGS. 1-2 are only exemplary and are not intended to assert or imply any limitation with regard to the environments in which aspects or embodiments of the disclosed subject matter may be implemented. Many modifications to the depicted environments may be made without departing from the spirit and scope of the present invention.

With reference now to the drawings, FIG. 1 depicts a pictorial representation of an exemplary distributed data processing system in which aspects of the illustrative embodiments may be implemented. Distributed data processing system 100 may include a network of computers in which aspects of the illustrative embodiments may be implemented. The distributed data processing system 100 contains at least one network 102, which is the medium used to provide communication links between various devices and computers connected together within distributed data processing system 100. The network 102 may include connections, such as wire, wireless communication links, or fiber optic cables.

In the depicted example, server 104 and server 106 are connected to network 102 along with storage unit 108. In addition, clients 110, 112, and 114 are also connected to network 102. These clients 110, 112, and 114 may be, for

3

example, personal computers, network computers, or the like. In the depicted example, server **104** provides data, such as boot files, operating system images, and applications to the clients **110**, **112**, and **114**. Clients **110**, **112**, and **114** are clients to server **104** in the depicted example. Distributed data processing system **100** may include additional servers, clients, and other devices not shown.

In the depicted example, distributed data processing system **100** is the Internet with network **102** representing a worldwide collection of networks and gateways that use the Transmission Control Protocol/Internet Protocol (TCP/IP) suite of protocols to communicate with one another. At the heart of the Internet is a backbone of high-speed data communication lines between major nodes or host computers, consisting of thousands of commercial, governmental, educational and other computer systems that route data and messages. Of course, the distributed data processing system **100** may also be implemented to include a number of different types of networks, such as for example, an intranet, a local area network (LAN), a wide area network (WAN), or the like. As stated above, FIG. 1 is intended as an example, not as an architectural limitation for different embodiments of the disclosed subject matter, and therefore, the particular elements shown in FIG. 1 should not be considered limiting with regard to the environments in which the illustrative embodiments of the present invention may be implemented.

With reference now to FIG. 2, a block diagram of an exemplary data processing system is shown in which aspects of the illustrative embodiments may be implemented. Data processing system **200** is an example of a computer, such as client **110** in FIG. 1, in which computer usable code or instructions implementing the processes for illustrative embodiments of the disclosure may be located.

With reference now to FIG. 2, a block diagram of a data processing system is shown in which illustrative embodiments may be implemented. Data processing system **200** is an example of a computer, such as server **104** or client **110** in FIG. 1, in which computer-usable program code or instructions implementing the processes may be located for the illustrative embodiments. In this illustrative example, data processing system **200** includes communications fabric **202**, which provides communications between processor unit **204**, memory **206**, persistent storage **208**, communications unit **210**, input/output (I/O) unit **212**, and display **214**.

Processor unit **204** serves to execute instructions for software that may be loaded into memory **206**. Processor unit **204** may be a set of one or more processors or may be a multi-processor core, depending on the particular implementation. Further, processor unit **204** may be implemented using one or more heterogeneous processor systems in which a main processor is present with secondary processors on a single chip. As another illustrative example, processor unit **204** may be a symmetric multi-processor (SMP) system containing multiple processors of the same type.

Memory **206** and persistent storage **208** are examples of storage devices. A storage device is any piece of hardware that is capable of storing information either on a temporary basis and/or a permanent basis. Memory **206**, in these examples, may be, for example, a random access memory or any other suitable volatile or non-volatile storage device. Persistent storage **208** may take various forms depending on the particular implementation. For example, persistent storage **208** may contain one or more components or devices. For example, persistent storage **208** may be a hard drive, a flash memory, a rewritable optical disk, a rewritable magnetic tape, or some combination of the above. The media

4

used by persistent storage **208** also may be removable. For example, a removable hard drive may be used for persistent storage **208**.

Communications unit **210**, in these examples, provides for communications with other data processing systems or devices. In these examples, communications unit **210** is a network interface card. Communications unit **210** may provide communications through the use of either or both physical and wireless communications links.

Input/output unit **212** allows for input and output of data with other devices that may be connected to data processing system **200**. For example, input/output unit **212** may provide a connection for user input through a keyboard and mouse. Further, input/output unit **212** may send output to a printer. Display **214** provides a mechanism to display information to a user.

Instructions for the operating system and applications or programs are located on persistent storage **208**. These instructions may be loaded into memory **206** for execution by processor unit **204**. The processes of the different embodiments may be performed by processor unit **204** using computer implemented instructions, which may be located in a memory, such as memory **206**. These instructions are referred to as program code, computer-usable program code, or computer-readable program code that may be read and executed by a processor in processor unit **204**. The program code in the different embodiments may be embodied on different physical or tangible computer-readable media, such as memory **206** or persistent storage **208**.

Program code **216** is located in a functional form on computer-readable media **218** that is selectively removable and may be loaded onto or transferred to data processing system **200** for execution by processor unit **204**. Program code **216** and computer-readable media **218** form computer program product **220** in these examples. In one example, computer-readable media **218** may be in a tangible form, such as, for example, an optical or magnetic disc that is inserted or placed into a drive or other device that is part of persistent storage **208** for transfer onto a storage device, such as a hard drive that is part of persistent storage **208**. In a tangible form, computer-readable media **218** also may take the form of a persistent storage, such as a hard drive, a thumb drive, or a flash memory that is connected to data processing system **200**. The tangible form of computer-readable media **218** is also referred to as computer-recordable storage media. In some instances, computer-recordable media **218** may not be removable.

Alternatively, program code **216** may be transferred to data processing system **200** from computer-readable media **218** through a communications link to communications unit **210** and/or through a connection to input/output unit **212**. The communications link and/or the connection may be physical or wireless in the illustrative examples. The computer-readable media also may take the form of non-tangible media, such as communications links or wireless transmissions containing the program code. The different components illustrated for data processing system **200** are not meant to provide architectural limitations to the manner in which different embodiments may be implemented. The different illustrative embodiments may be implemented in a data processing system including components in addition to or in place of those illustrated for data processing system **200**. Other components shown in FIG. 2 can be varied from the illustrative examples shown. As one example, a storage device in data processing system **200** is any hardware apparatus that may store data. Memory **206**, persistent

storage **208**, and computer-readable media **218** are examples of storage devices in a tangible form.

In another example, a bus system may be used to implement communications fabric **202** and may be comprised of one or more buses, such as a system bus or an input/output bus. Of course, the bus system may be implemented using any suitable type of architecture that provides for a transfer of data between different components or devices attached to the bus system. Additionally, a communications unit may include one or more devices used to transmit and receive data, such as a modem or a network adapter. Further, a memory may be, for example, memory **206** or a cache such as found in an interface and memory controller hub that may be present in communications fabric **202**.

Computer program code for carrying out operations of the present invention may be written in any combination of one or more programming languages, including an object-oriented programming language such as Java™, Smalltalk, C++ or the like, and conventional procedural programming languages, such as the “C” programming language or similar programming languages. The program code may execute entirely on the user’s computer, partly on the user’s computer, as a stand-alone software package, partly on the user’s computer and partly on a remote computer, or entirely on the remote computer or server. In the latter scenario, the remote computer may be connected to the user’s computer through any type of network, including a local area network (LAN) or a wide area network (WAN), or the connection may be made to an external computer (for example, through the Internet using an Internet Service Provider).

Those of ordinary skill in the art will appreciate that the hardware in FIGS. 1-2 may vary depending on the implementation. Other internal hardware or peripheral devices, such as flash memory, equivalent non-volatile memory, or optical disk drives and the like, may be used in addition to or in place of the hardware depicted in FIGS. 1-2. Also, the processes of the illustrative embodiments may be applied to a multiprocessor data processing system, other than the SMP system mentioned previously, without departing from the spirit and scope of the disclosed subject matter.

As will be seen, the techniques described herein may operate in conjunction within the standard client-server paradigm such as illustrated in FIG. 1 in which client machines communicate with an Internet-accessible Web-based portal executing on a set of one or more machines. End users operate Internet-connectable devices (e.g., desktop computers, notebook computers, Internet-enabled mobile devices, or the like) that are capable of accessing and interacting with the portal. Typically, each client or server machine is a data processing system such as illustrated in FIG. 2 comprising hardware and software, and these entities communicate with one another over a network, such as the Internet, an intranet, an extranet, a private network, or any other communications medium or link. A data processing system typically includes one or more processors, an operating system, one or more applications, and one or more utilities. The applications on the data processing system provide native support for Web services including, without limitation, support for HTTP, SOAP, XML, WSDL, UDDI, and WSFL, among others. Information regarding SOAP, WSDL, UDDI and WSFL is available from the World Wide Web Consortium (W3C), which is responsible for developing and maintaining these standards; further information regarding HTTP and XML is available from Internet Engineering Task Force (IETF). Familiarity with these standards is presumed.

FIG. 3 is a high level flow diagram of a preferred embodiment of the invention. In the embodiment, a user will select a track to input into the music composition engine, step **301**. The user interface can list a set of music already stored in the music store, or it could be a web interface which would retrieve the selected piece of music from an Internet search. One preferred user interface uses voice recognition, so that the user could state something as simple as “Please start with the music from Game of Thrones”. The user interface would retrieve the desired music or information on how the music could be licensed for use in the music composition engine. In a preferred embodiment of the invention, a single selection of music is used as input to the system. However, as will be discussed below, multiple music selections can be used in other embodiments of the invention. It is one intent of the invention to simplify the input required so that a layman can use embodiments of the invention. The preferred embodiments of the invention do not require extensive libraries of music to be first analyzed by the music engine or to be selected by the user.

In step **303**, the music engine will extract the musical characteristics from the selected music. In the preferred embodiment, the musical characteristics are expressed as a vector or matrix of musical values. The technique used in the preferred embodiment will be discussed in greater detail below.

In step **305**, the model is perturbed in a direction indicated by the user’s intent. As part of the user interface, the user can indicate how the output of the music engine should be different than the input music. For example, returning to the example of a voice input user interface, the user might state: “I need 5 minutes of music for a video game and please start with the music from Game of Thrones, but make it happier”. So the inputs from the user direct the music engine to a set of requirements, e.g., 5 minutes of music, music suitable for replay on a game console or personal computer, music based on Game of Thrones, but in a major key at an upbeat tempo (happy). Other user intents such as “sad”, “slow”, “fast”, or “triumphant” could be requested by the user. In alternative embodiments, user intents such as genre, e.g., “classical”, “jazz” and “country” could be requested by the user. For example, “I want classical music based on the Beatles’ “Let It Be” of six minutes in duration” would produce a piece of music at the requisite length using classical elements with musical elements from the input music. Yet other user intents could be for an activity—running, studying, work, or the user intent could be for a particular purpose—music for a video game, hold music for call waiting, elevator music, party dance music. Each of the requested perturbations is associated with a rule set, examples of which will be discussed below.

Further, embodiments of the invention also include adding “random” perturbations to the input musical piece selected as the “seed”. The random perturbations can be in addition to the perturbations based on the user intent, or by themselves. In one embodiment, the random perturbations are also the user intent, when how close to or similar the newly created music should be to the input music is selected. Returning to the example of the voice input interface, if the user indicates that he wants a piece of music “just like” the input piece, relatively fewer or relatively smaller random perturbations would be added as compared to a request that the music have “a faint resemblance” to the input piece which would have more or larger perturbations. The “random” perturbations do not have to be truly random in a statistical sense; in general, the random perturbation will follow a musical rule, e.g., a pitch perturbation will be on a

music whole tone or half tone in a musical scale. Other musical notions of pitch could be used, e.g., atonal, twelve tone, pitch class.

Next, in step 307, the source track is reconstructed iteratively based on the perturbation specified by the user and/or the random perturbations. In a preferred embodiment of the invention, the music engine is comprised of a plurality of Restricted Boltzmann Machines (RBM) coupled together to form a Deep Belief Network (DBN) operated in an unsupervised manner. Thus, continuing with the example above, potentially hundreds of “versions” of Game of Thrones are created using the perturbation rules. These versions of Game of Thrones are expressed by the same sort of musical vector or matrix of musical characteristics as the original input, and are only reassembled as music if a particular level within the DBN was selected for output in the particular embodiment of the invention. The culmination of the iterative reconstruction is used in embodiments of the invention as the vector from which to extract musical characteristics to be used by the music engine in the final composition.

In step 309, the final output track(s) is output by the music engine. The number of tracks output is a user configurable parameter in some embodiments of the invention. If a user selected five tracks to be created, so that a selection was available, the system would present the five musical creations. The system could either run five times using slightly different perturbations of the initial vector, or different “levels” within the neural network could be selected for creating output.

The music engine is run in an unsupervised manner. Thus, human supervision of the music engine is not required, and thus, is easier for a layman user to create musical compositions according simple directives.

FIG. 4 is a high level flow diagram of the transformation of a vector including musical information according to the present invention. The process begins in step 401 with the input vector of musical characteristics in a form suitable for further reconstruction by the music engine. As is mentioned above, embodiments of the invention use Restricted Boltzmann (RBM) machines. An RBM defines a distribution over some input vector  $x$ . In one embodiment, the input vector  $x$  is a midi file with musical characteristics like pitch, rhythm, velocity, etc. incorporated therein. Each neuron in the starting visible layer will hold musical information about pitch, rhythm and other musical characteristics as they exist in particular time in the input musical piece. That is, each neuron represents a temporal unit ( $\frac{1}{8}$ th note,  $\frac{1}{16}$ th note, etc.) and a value of representing the pitch played at the corresponding time.

In step 403, the input vector is perturbed according to the rules corresponding to the intent of the user and/or a random perturbation. For example, if the user requested a “happy” or “triumphant” output, pitches selected from a key signature associated with “happy” in the system rule set would be inserted in the perturbed vector as a perturbation node. In other embodiments of the invention, instead the system changes a value in the input vector/matrix, e.g., any minor chords in the input vector can be changed to major chords. If the user requested a “faster” track, the timing of perturbation nodes in the perturbed vector information is changed appropriately, i.e. eighth notes would be inserted rather than quarter notes. In other embodiments of the invention, the system changes the input vector nodes Long sustained notes in the original input vector, e.g., whole notes, could be

shortened, e.g., to half notes or quarter notes. In this step, a plurality of variations of the originally input track are produced.

In preferred embodiments, enough perturbation is added to the input vector so that the new music piece that does not sound too much like the original. There is an interplay between the amount of perturbation and the length of training. If the temporal unit for each neuron is  $\frac{1}{8}$ th of a note and four to ten additional perturbation neurons are added per original neuron, and if the system does not train for long, the output music will be sufficiently different. In general, the less the system trains, the more different the output music will be from the input music, and the more perturbation is added, the more different the output will be.

To prevent too much perturbation from causing the output music piece to be unmusical, in some embodiments of the invention, post processing makes sure that the final output will always have notes that belong to a given key signature. In that sense, the output will always be musically accurate. However, the output sounding pleasant is a subjective opinion. In general, the longer the system trains, the more pleasant the output music will be. However, it is also true that the longer the system trains, the closer the output music becomes to the original piece, and there is a dilemma in choosing to training for longer times since a new and different song is desired. Therefore, to compensate for longer training times so that the output will be pleasant, the system can add more perturbation to make sure the output remains different.

The neural networks then perform unsupervised learning of the variations of the original track produced as described above, in step 405. Because of the variations according to the perturbations, the learning is much “richer” than it would have been based on the single input track. Yet the advantage for the user is that a single input track is required, rather than a music library and a set of music rules as in the prior art. The learning process is described in greater detail below.

Finally, in step 407, the output music piece is produced by the music engine. The output track may resemble the original input track, but changed in the ways specified by the user. As discussed above, in one preferred embodiment, the values in the neurons marked as “perturbation” neurons are removed from the musical vector or matrix in the last level of the DBN to produce the output piece. In another embodiment, the perturbed neurons need not be removed from the output which will make the output music more certainly different from the input piece as additional neurons have been added.

FIG. 5 depicts a general Restricted Boltzmann Machine (RBM) which can be used in the present invention. An RBM is a stochastic neural net with one visible layer 501 of neural net nodes/units which communicate the values, in the present invention, the input set of musical characteristics, to a hidden layer 503 of neural net nodes/units. In a neural network, each node is a neuron-like unit whose binary activations depend on the neighbor node to which it is connected. Stochastic means that these activations have a probabilistic element. Restricted Boltzmann Machines, and neural networks in general, work by updating the states of some neurons given the states of others. A Restricted Boltzmann Machine is different from other Boltzmann machines in that the neurons in the visible layer are not connected to each other (restricted) and the neurons in the hidden layer are also not connected to each other. In a learning mode, the hidden nodes act as latent variables which allow the RBM to capture higher order information in the input set entered into the visible layer. Learning comprises finding a set of weights

and biases **511** which make the input vector **501** good. In the preferred embodiments of the invention, the learning is performed in an unsupervised manner so that the music engine automatically discovers the higher order musical information without user intervention beyond selection of the initial input parameters.

Restricted Boltzmann Machines are used to perform a binary version of factor analysis. Rather than asking a user to rate a set of music on a scale, or to indicate which musical characteristics they favor, the music vector of musical characteristics from the original piece of music as modified by the perturbations are arranged as nodes in the visible layer, and the RBM will try to discover latent factors that can explain the musical characteristics which are appealing to the user as evidenced by the choice of music (and as modified by the user's intent) and store these values in the nodes in the hidden layer. In the present invention, the initial visible nodes represent the musical characteristic vector from the input piece, plus the perturbation nodes representing the user intent and/or random perturbations and hidden nodes represent the relationships between the visible nodes.

Multiple nodes are in each layer, for example, node **509** in visible layer **501** and node **507** is in hidden layer **503**. The number of nodes selected in the visible layer is determined by the input song, i.e. if the input song has ten  $\frac{1}{4}$  notes, and the temporal unit for each neuron is a quarter note ( $\frac{1}{4}$ th of a note), then the starting number of neurons in the visible layer is 10 (before perturbation). If the temporal unit of each neuron is  $\frac{1}{8}$ th of a note, then the number of neurons in the visible layer is 20. Once it is determined that the song has 10 neurons (i.e. 10 quarter notes with each neuron representing a  $\frac{1}{4}$  note), then the perturbation neurons are added to the input vector. In one preferred embodiment, the unit of perturbation adds 4 perturbation neurons for every  $\frac{1}{4}$ th note in the input music piece. For a 10 quarter note input song, this means that the total number of neurons in the visible layer will be =50 neurons ((1 actual  $\frac{1}{4}$ th note neuron+4 perturbation neuron)\*10=50 neurons). In one preferred embodiment, the hidden layer typically contains half the neurons in the visible layer. Those skilled in the art would recognize that other ratios of neurons between the visible and hidden layers are possible. In general, the number of neurons in the hidden layer should be less than the number of neurons in the visible layer. Thus, the number of neurons depends on the length of the song and the amount of perturbation that is added. Longer songs have more neurons. More perturbation also indicates more neurons.

As another illustrative embodiment, given that the temporal unit of each neuron is  $\frac{1}{8}$ th note, however, in the input song, some notes last for  $\frac{1}{2}$  note. In this case, this half note is divided into 4 neurons (each neuron represents half the pitch, but is only  $\frac{1}{4}$ th note long). Then each neuron also has an additional tie neuron associated with it, indicating it is part of a longer note. Therefore, each temporal unit will now contain 2 neurons: (a) one indicating the actual pitch being played and (b) two indicating whether it is part of a tie note (an elongated note or note).

In preferred embodiments of the invention, the input vector of the lowest level RBM in the DBN is altered by adding new components to the input vector and marking them as perturbation nodes. That is, if a user requested a "happy" output, the perturbation neurons would be assigned with pitch values from a major keys associated with a "happy" mood. If the user requested, a "faster" track, the perturbation neurons would be assigned eighth note values rather than quarter note or half note values. By marking the

added neurons as perturbation neurons, they can be removed from the extracted vectors to produce the final output music piece(s).

In the preferred embodiment, the RBMs are trained using a process called Contrastive Divergence. This process is described in reference to FIG. 6.

As their name implies, Restricted Boltzmann Machines (RBMs) are a variant of Boltzmann machines, with the restriction that their neurons must form a bipartite graph: a pair of nodes from each of the two groups of units, commonly referred to as the "visible" and "hidden" units respectively, may have a symmetric connection between them, and there are no connections between nodes within a group. By contrast, "unrestricted" Boltzmann machines may have connections between hidden units. This restriction allows for more efficient training algorithms than are available for the general class of Boltzmann machines, in particular, the gradient-based Contrastive Divergence algorithm. Contrastive Divergence involves three steps:

(a) Stochastically approximate features of the visible layer and represent it in the hidden layer.

(b) Reconstruct the visible layer using an approximate version of hidden layer using Gibbs Sampling.

(c) Iterate until reconstructed (learned) visible layer is similar to original hidden layer

In a preferred embodiment, Gibbs Sampling is used for reconstructing the visible layer. In Gibbs Sampling, each variable is sampled given the other variables, according to the following procedure:

(a) Sample the value of all the elements in one layer (e.g., the hidden layer), given the value of the elements of another layer (e.g., the visible layer).

(b) Alternate between the layers—i.e. sample the values of the visible layer given the values of the hidden layer.

As shown in the drawing, according to one embodiment of the present invention, new music can be created in real time by adding perturbations to an input vector which expresses the music characteristics of the selected input piece of music. This input vector **601** is shown as a set of values arranged in a vector according to time. As shown, C#, E . . . B represent the notes in the song "Mary Had a Little Lamb" in the order in which they occur. Other musical characteristic information can also be in the vector such as chords, timing, key change, dynamics (e.g., crescendo, fortissimo), etc., each in their own neuron, however, for simplicity in illustration, only the pitch information is illustrated.

The input vector **601** is fed into the visible layer **603** of the RBM wherein each characteristic is fed into a node or neuron of the visible layer. In some embodiments of the invention, the input vector can be expressed as a matrix. According to the invention, these characteristics are perturbed according to an intent bias and/or a random bias. As shown in the drawing in this embodiment, the perturbations are inserted as their own nodes or neurons in the visible layer. Here, the user has chosen a "sad" version of "Mary Had a Little Lamb", so pitches associated with sadness, e.g., a D# minor key, are inserted into neurons in the visible layer. Also as shown in the drawing, a random perturbation is added into the visible layer to add richness to the discovery process.

The hidden layer of the RBM is trained on the relationships between the elements of the perturbed vector **603**. This is an iterative process.

The visible layer **603** of neurons is connected to the hidden layer **605** of neurons using a set of weights. On the first iteration, these weights are assigned a random value.

These weights are then multiplied with the value of the neurons in the visible layer, and then passed through an activation function to arrive at the first values for the neurons in the hidden layer. The neurons in the hidden layer hold  $P(H/X)$ .  $P(H/X)$  describes the probability of the hidden layer given the values of the visible layer and the weight matrix.

Next, the values in the hidden layer **605** are sampled to populate the first learned visible layer **607** which contains nodes corresponding both the perturbed according to intent bias and random bias. The following steps explain how this is done.

To reconstruct the learned visible layer **607**, given the hidden layer **605** just obtained from the previous step, the values of the neurons in the hidden layer ( $P(H/X)$  obtained from the previous step) are multiplied by the transpose matrix of the weights. The result of the multiplication is passed through an activation function. The result from the activation function will now represent the new learned visible layer also known as  $P(X|H)$ .  $P(X|H)$  is the probability of the visible layer given the values of the hidden layer and the weight matrix.

This concludes the first iteration of learning. To determine the error of learning, the system subtracts the value of each neuron from the original visible layer from the value of each neuron in the learned visible layer, sums these differences, and takes the root mean squared value of these differences. Then the system updates the weight matrix based on the error that has been calculated. In the second iteration, the system uses the learned visible layer of the previous iteration as the starting visible layer, calculates  $P(H/X)$  (i.e. the probability of the hidden layer given the updated weight matrix and the learned visible layer). Next, the system calculates  $P(X|H)$  (not shown in figure) (i.e. probability of second learned visible layer given the weight matrix and the hidden layer from the previous step). The system then determines the error of learning the second iteration (i.e. subtracts original visible layer from the second learned visible layer, sums the differences, and takes the root mean squared error.) Then, the weight matrix is updated based on this error. This concludes the second iteration of training the first RBM. This process continues until training is stopped once an acceptable error limit is reached. Note, training iterations can stop whenever the user chooses by configuration of the RBM. This is how the first RBM is trained.

Once we have trained the first RBM, the final values of the neurons of the hidden layer obtained during the last iteration of training of the first RBM is used as the visible layer for the next RBM. Then the next RBM is trained as discussed above for the first RBM.

As depicted in FIG. 7, a Deep Belief Network (DBN) **700** is composed of a plurality of layers of Restricted Boltzmann Machines (RBM) **701**, **703**, **705** or other like neural networks arranged in a hierarchical manner, where each sub-network's hidden layer serves as the visible layer for the next. This also leads to a fast, layer-by-layer unsupervised training procedure, where contrastive divergence is applied to each sub-network in turn, starting from the "lowest" pair of layers (the lowest visible layer being a training set). Once an RBM has been trained, that is, has learned a representation of the visible layer to the hidden layer, the probabilities of a first RBM in the hidden layer are fed as the visible layer to the next RBM in the DBN.

FIG. 7 shows the first three RBMs **701**, **703**, **705** of the DBN **700** for ease of illustration. In some embodiments of

the invention, there would be many more layers of RBMs, depending on the embodiment. The first RBM **701** contains the initial visible layer **707** which includes the input vector values and any perturbed values. After training, the values in hidden layer **709** of the first RBM are used in the nodes of the second visible layer of RBM **703**. Next, the nodes in the next hidden layer **711** belonging to the second RBM **703** are trained and the trained values are used as the visible layer for the third RBM **705**. Finally, the nodes in the hidden layer **713** of the third RBM **705** are trained. In general, each higher level RBM will have fewer neurons than the RBM below it. One embodiment of the invention halves the neurons in each succeeding RBM. For example, if the first RBM **701** starts with 200 neurons in the first visible layer **707**, then there will be 100 neurons in the hidden layer **709** of the first RBM **701**. This hidden layer **709** (after training) will act as visible layer for the next RBM **703**. The hidden layer **711** in the second RBM **703** will then contain 50 neurons, etc.

This process continues until the final layer of the Deep Belief Network is reached. In one preferred embodiment of the invention, this final layer is used to produce the output of the music composition system of the present invention. Using Gibbs sampling, the embodiment works down from the topmost hidden layer (for example, the third RBM hidden layer **713** in the drawing) to reconstruct a layer analogous to the bottommost visible layer (for example, the first RBM visible layer **707**). Once the neuron values are calculated for the bottommost visible layer, the perturbation neurons are removed, and then, the final set of neurons remains which represents the learned musical piece. If another learned piece is needed, the system performs the training again with different perturbations.

As described above, no additional biases (perturbation nodes) are added in a higher level visible layer, however, in another embodiment, additional perturbation can be added to each RBM in the DBN. Also in another embodiment, the perturbation neurons need not be removed from the reconstructed bottommost visible layer to obtain the final musical output.

If a particular length of music is desired, the system can shorten the output music, or if a longer piece is needed, concatenate multiple pieces or segments of pieces to arrive at the desired length. In another embodiment of the invention, if the user wants a piece of a certain length, the number of nodes in the input music vector is chosen to achieve the desired output length. For example, multiple learned pieces of the same input can also be concatenated to get a longer desired output—or some nodes can be removed from the visible layer to get a smaller desired output.

One of the most dispositive musical characteristics in terms of creating the musical output is the pitch associated with the melody of the input vector at a given point in time. As is mentioned above, when the input vector is perturbed in the initial visible layer of the first RBM, pitch values associated with different key signatures or intervals within the original music input can be inserted into a neuron or node to effect the intent of the user, e.g., "sad", "happy", "scary" and so forth. Thus, in one preferred embodiment of the invention, rules are created so that in response to an expressed user intent, pitches having an interval from a note in the input piece are inserted into the first visible layer. Table 1 contains a set of such rules for the key of C.

Perturbation Neurons for Different Moods and Intent:

Interval and example notes	User Intent	Comments
Major seventh C to B	"Spooky", "Scary", "Strange"	Discordant, driving feeling to resolve it. It has a strange and ethereal feel.
Minor seventh C to B flat	"Mysterious", "Scary"	Feeling of suspense and expectancy.
Major sixth C to A	"Triumphant", "Happy"	Uplifting sound associated with major intervals associated with movement.
Minor sixth C to G#	"Sad", "Sleepy"	Sad or melancholy sound. Used in Chopin's Nocturnes.
Fifth C to G	"Happy"	Peaceful, open, cosmic, blissful.
Augmented 4 <sup>th</sup> C to F#	"Scary"	Discordant sound in harmony. Ethereal sound when used in melody rather than harmony.
Fourth C to F	"Happy", "African"	Open, active, unresolved feeling about it. Used in African music
Major third C to E	"Happy"	Bright happy quality of familiar harmonies and melodies
Minor third C to D#	"Sad", "Scary"	Melancholy, or gloomy. The predominant sound of minor keys.
Major second C to D	"Scary", "Slavic"	Discordant. Used in Slavic music.
Minor second C to C#	"Scary"	Very discordant. Scary music.

Using these rules, if the user intent was for a "happy" output, the input vector would be perturbed by placing notes having an interval of a major third, fourth, fifth or sixth from an adjacent pitch in the vector. If the user intent was for a "sad" output, the vector would be perturbed by inserting notes having an interval of a minor third or minor sixth to adjacent pitches in the input vector.

Alternatively, a different set of rules could insert pitches from different key signatures which are associated with different moods. The selected user intent would be used to select a rule from the set of rules. One skilled in the art would recognize that many synonyms could be added to the rule set to help the system determine user intent.

TABLE 2

Rule set for key signature	
Key Signature	User Intent
C major:	"happy", "warlike", "studying"
C minor:	"lost", "sad"
D major:	"joyous", "very happy", "very warlike"
D minor:	"serious", "pious", "religious"
E major:	"cruel", "hard", "mean"
E minor:	"active", "fighting", "boisterous"
F major:	"feminine", "amorous", "sad"
F minor:	"furious", "angry", "agitated"
G major:	"lost", "sad"
G minor:	"serious", "triumphant", "magnificent"
A major:	"serious", "sad"
A minor:	"joyful", "happy", "pastoral"
B major:	"tender", "sad"
B minor:	"harsh", "angry"
B# major:	"solitary", "sad", "melancholic"
B# minor:	"magnificent", "joyful", "running"
Bb minor:	"obscure", "terrible", "very sad"

For example, if the user indicated that the output music should be "happy", the system could select notes from one of the key signatures A major, C major or D major. If the user indicated that the output music should be "sad", the system could select notes from one of the key signatures B minor, F minor or E minor. Several perturbation nodes inserted together in the input vector will tend to establish the new key. Another embodiment uses post processing to make sure

that the reconstructed vector after training is consistent. Each neuron is examined to determine whether it lies in the desired key signature. If it doesn't, the post processor modifies the neuron to make it fit into the key signature, for example, changing C to C# to make the neuron fit a D major key.

Yet other rule sets can be used to create musical output in a desired genre, e.g., classical, rock, jazz, blues, rap, etc. For example, if a user expressed an intent to create a blues version of "Silent Night", the "blues" rule could contain instructions to add perturbations in a "blues" scale, flattening the third and fifth notes in the desired key, perturbations with a "blues" rhythm, perturbations using the I, IV and V chords in the desired key and so forth. Alternatively, a "blues" song, e.g., "I'm Ready" by Muddy Waters, might be added to the input music vector as discussed in the two song embodiment below in connection with FIG. 8.

FIG. 8 depicts the operation of an RBM according to another embodiment of the invention. In this embodiment, two songs are used to create the first visible layer 801 for the system. As shown, musical characteristics from Song A, for example, "Mary Had A Little Lamb" and from Song B, for example, "O Susannah" are intermingled. Let's say that the temporal unit of splitting is a 1/4 note. The first 1/4 note of Mary is used, next the perturbations are added, then the 1st 1/4 note of Susannah is used, the perturbations are added, then the next 1/4 note of Mary is used and so on and so forth. In another embodiment, the first few notes of Mary and then the next few notes of Susannah and some perturbation neurons, and so on. If the user wants the output music to be "more" like Mary Had a Little Lamb, the system can achieve that goal in several ways: (a) by adding more Mary neurons, (b) by adding fewer Susannah neurons, (c) by adding less perturbation to Mary, (d) by adding more perturbation to Susannah. If there was a phrase that the user wanted particularly, the neurons that represent that phrase can be repeated more frequently.

As described above, the hidden layer 803 is trained so that the higher level music relationship can be extracted. Also, as described above, the values from the hidden layer would be passed up to successively higher levels of RBMs in the DBN until the final layer of the Deep Belief Network is reached.

Also present in this embodiment are perturbation nodes respectively named “Major Bias” **805** and “Minor Bias” **807**. This represents that the system could add pitches into the perturbation nodes from a major and/or a minor key signature according to an expressed user intent.

The invention has many possible applications and embodiments. Because of the simplicity of input, a cloud based cognitive music composition service could be provided to users. A streaming service could provide new music, wherein the user may suggest music that they like and the system generates more similar music. Producers and composers can use the invention to create music based on intent (e.g., mood—slow, happy, vibrant, or purpose—running, studying). Music can be created for hold music for conference calls, waits for customer service, elevator music and so forth.

FIG. **9** shows a distributed embodiment of the invention. In the figure, client tablet **901**, client laptop **902** and client smart phone **903** are communicatively coupled to a cloud based cognitive music composition service **905** found in cloud environment **907**. As shown, the music manager element **909** receives requests from the user devices **901**, **902**, **903** and with reference to the rules **911** translates them into a perturbed music vector or matrix to DBN **913**. The music manager **909** then takes the output from the DBN **913** and formats it into music in an acceptable format for the requesting device. The client device input from the respective devices can be different. In one embodiment of the invention, the user interfaces from the tablet **901** and laptop **902** might be graphical user interfaces, while the smart phone user interface might be a voice input based interface.

FIG. **10** shows one embodiment of a user interface suitable for a tablet computer. A set of four input icons **1001**, **1003**, **1005**, and **1007** is available for user selection of songs and intent for the music composition service. Pulldown menus **1010**, **1012**, **1014** and **1016** are available to select from the available songs in the library. Pulldown menus **1011**, **1013**, **1015** and **1017** are available to select from the available user intents. As shown, in input box **1001**, the user has selected “Song A” and a “sad” user intent. In input box **1003**, the user has selected “Song B” and a “classical” user intent.

This embodiment of the invention allows the user to choose a single song as input by selecting the “Learn Individual” button **1018**, or multiple songs to input by selecting the “Learn Mix” button **1019**. In the drawing, the “Learn Mix” mode has been selected as well as “Song A” and “Song B” with their respective user intents. This selection causes an icon **1020** representing Song A and an icon **1021** representing Song B to appear in the interface. A slider **1022** allows the user to control how much influence Song A and Song B should have on the final musical creation. In the drawing, the user has selected for Song A to have a stronger influence. When the user is satisfied with the selections, the submit button **1023** is selected by the user. In response to the user request, the music composition service will start with the musical characteristics from Song A and Song B, add perturbations according to the expressed user intent for each song and add these parameters to the first visible layer of the DBN. Also as the user has indicated that Song A is to have more influence on the output music piece, more neurons in the input vector will have musical characteristics from Song A. For example, some of the notes from Song A may be repeated in multiple neurons in the first visible layer. After the music composition service has completed, the play button **1025** is enabled, indicating to the user that the musical creation is available. If the user is satisfied with the

output, it can be saved using save button **1027**. Alternatively, the user can change the selected parameters and try again.

Those skilled in the art would recognize that many user interfaces could be used for a user to request services from the music composition service including a voice user interface or user interface have text entry fields in which a user enters one or more desired musical selections as input pieces.

Although the illustrative embodiments of the invention have been described in terms of a Deep Belief Network (DBN) composed of Restricted Boltzmann Machines (RBM), other neural nets could be used to implement the invention. In general, any type of unsupervised neural net such as a DBN composed of RBMs, a convolutional neural network (CNN), a convolutional deep belief network (CDBM), a Self-Organizing-Map (SOM) can be used to implement the present invention. The alternative embodiments contain the following features:

(a) set of input neurons which are filled with musical data obtained from a midi file or original composition based on mp3, or other audio source;

(b) set of perturbed neurons (perturbed based on user intent—sad, happy, slow, classical, running, game music, etc.);

(c) A learning algorithm. The learning algorithms may be different for each network (see below for different examples), but they are all trying to find hidden features and representations of the perturbed input vector;

(d) An output vector comprising the set of neurons that obtained after training which will then be processed to produce the final musical vector for the output music piece.

Factors in common for these techniques are the lack of a dependence on prior knowledge or the existence of difficult to design hand-engineered features.

For each of these embodiments, the learning algorithms are as follows:

(a) CNN: back-propagation with gradient descent

(b) RBM, DBN, CDBN: contrastive divergence and Gibbs sampling

(c) SOM: competitive learning algorithms (like Competitive Hebbian learning)

All these neural networks and their learning algorithms are well known to those skilled in the art of machine learning.

The DBN/RBM implementations are viewed as preferred in many applications. However, for some applications, they may fail to scale well with larger and higher dimensional problem sizes. For example, when training songs of a longer duration, e.g., a symphony, it is possible that the DBN/RBM model may not be able to sufficiently capture feature representations, and may take longer to train.

Higher dimensional problems usually have the following unique representations:

(a) low level features are finer and more local; and

(b) high level features are coarser and more global.

For longer works, an embodiment of the invention can use convolutional neural networks (CNNs):

Convolutional neural networks are comprised of one or more convolutional layers (often with a subsampling step) and then followed by one or more fully connected layers as in a standard multi-layer network. For the musical cognitive composing service of the present invention, musical pieces that have multiple parts can be learned very easily using CNNs as explained below. Individually, the different parts in a complex and long composition may have features and representations that are more local (consecutive measures may follow the same key/time signature, same set of pitches,

etc.), but the musical piece as a whole also has a set of global characteristics. These type of workloads are typically well suited for learning using CNNs because CNNs build local connectivity into their model by the sharing of weights.

CNNs build coarser connectivity by using some notion of sub-sampling that reduces the variance over the different features that have been identified in the previous layers. The input to CNNs will be similar to RBMs (an input vector with perturbed neurons). The learning algorithm will have some form of back-propagation with a gradient descent.

In other alternative embodiments, a convolutional deep belief network (CDBN) can be used. A CDBN is a scalable generative model for learning hierarchical representations of its input (e.g., musical pieces). The CDBN is similar to a DBN, but the weights between the hidden and visible layers in each of the convolutional RBMs (that make up the CDBN) are shared among all locations in an image. The same perturbed input vector is used as before in the DBN, and the learning algorithm also remains the same (Contrastive Divergence and Gibbs Sampling). The major difference is in the sharing of the weights among different parts of the visible and hidden layers. This allows us to detect finer local features more easily without losing the high-level representations.

A big benefit of any type of convolutional net is that they are easier to train and have many fewer parameters than fully connected networks with the same number of hidden units. This makes the training more computationally tractable. The output is interpreted in the same way for both CNNs and CDBN (i.e. the final set of neurons obtained after training the model using the perturbed input vector is converted into a midi file or other musical output).

The subject matter described herein has significant advantages over the prior art. The music engine is run in an unsupervised manner. Thus, human supervision of the music engine is not required, and thus, it is easier for a layman user to create musical compositions according simple directives. Prior art requires extensive libraries of music, tracks and musical rules. The prior art predictive models are pretrained, requiring extensive time, and require a good deal of musical knowledge to operate. The invention can produce a musical composition in real time with no prior training on the part of the system or operator. Most prior art computer aided music composition does not account for the intent of the user, i.e. the desired result, and if they do so, the input needed to ask for a desired result is unintuitive and complicated. The present invention does not need extensive musical knowledge on the part of the operator. Furthermore, the invention allows the user to state in simple and intuitive terms the desired result: "Make it like Game of Thrones but happier", "Use the Charlie Brown theme, but make it sound more like Beethoven".

The functionality described above may be implemented as a standalone approach, e.g., a software-based function executed by a processor, or it may be available as a managed service (including as a web service via a SOAP/XML interface). The particular hardware and software implementation details described herein are merely for illustrative purposes are not meant to limit the scope of the described subject matter.

The scheme described herein may be implemented in or in conjunction with various server-side architectures including simple n-tier architectures, web portals, federated systems, and the like. The techniques herein may be practiced in a loosely-coupled server (including a "cloud"-based environment).

Still more generally, the subject matter described herein can take the form of an entirely hardware embodiment, an entirely software embodiment or an embodiment containing both hardware and software elements. In a preferred embodiment, the function is implemented in software, which includes but is not limited to firmware, resident software, microcode, and the like. Furthermore, as noted above, the music composition functionality can take the form of a computer program product accessible from a computer-usable or computer-readable medium providing program code for use by or in connection with a computer or any instruction execution system. For the purposes of this description, a computer-usable or computer readable medium can be any apparatus that can contain or store the program for use by or in connection with the instruction execution system, apparatus, or device. The medium can be an electronic, magnetic, optical, electromagnetic, infrared, or a semiconductor system (or apparatus or device). Examples of a computer-readable medium include a semiconductor or solid state memory, magnetic tape, a removable computer diskette, a random access memory (RAM), a read-only memory (ROM), a rigid magnetic disk and an optical disk. Current examples of optical disks include compact disk-read only memory (CD-ROM), compact disk-read/write (CD-R/W) and DVD. The computer-readable medium is a tangible item.

The computer program product may be a product having program instructions (or program code) to implement one or more of the described functions. Those instructions or code may be stored in a computer readable storage medium in a data processing system after being downloaded over a network from a remote data processing system. Or, those instructions or code may be stored in a computer readable storage medium in a server data processing system and adapted to be downloaded over a network to a remote data processing system for use in a computer readable storage medium within the remote system.

In a representative embodiment, the administrator configurator and the suspension workflow components are implemented in a special purpose computer, preferably in software executed by one or more processors. The software is maintained in one or more data stores or memories associated with the one or more processors, and the software may be implemented as one or more computer programs. Collectively, this special-purpose hardware and software comprises the functionality described above.

While the above describes a particular order of operations performed by certain embodiments of the invention, it should be understood that such order is exemplary, as alternative embodiments may perform the operations in a different order, combine certain operations, overlap certain operations, or the like. References in the specification to a given embodiment indicate that the embodiment described may include a particular feature, structure, or characteristic, but every embodiment may not necessarily include the particular feature, structure, or characteristic.

Finally, while given components of the system have been described separately, one of ordinary skill will appreciate that some of the functions may be combined or shared in given instructions, program sequences, code portions, and the like.

The techniques herein provide for improvements to another technology or technical field, namely, identity access and management systems, as well as improvements to the functioning of recertification processes within such systems.

Having described our invention, what we now claim is as follows.

The invention claimed is:

1. A method for generating a musical composition based on user input, comprising:
  - responsive to user input, extracting a first set of musical characteristics from a first input musical piece;
  - preparing the first set of musical characteristics as an input vector into an unsupervised neural net comprised of a plurality of computing layers, wherein each computing layer is composed of a set of nodes, wherein the input vector is prepared by perturbing the first set of musical characteristics according to a user intent expressed in the user input to create a perturbed input vector;
  - providing the perturbed input vector into a first set of nodes in a first visible layer of the unsupervised neural net;
  - operating the unsupervised neural net using the perturbed input vector to calculate an output vector from a higher set of nodes of the unsupervised neural net; and
  - using the output vector to create an output musical piece.
2. The method as recited in claim 1, wherein the plurality of computing layers comprise a plurality of Restricted Boltzmann Machines (RBM).
3. The method as recited in claim 1, wherein the user intent is selected from the group consisting of a mood, a genre of music and an activity to be performed while listening to the output musical piece.
4. The method as recited in claim 2, wherein a rule directs a selection of a set of pitches from a key signature associated with the user intent.
5. The method as recited in claim 1, wherein the perturbing includes inserting random values into respective ones of the first set of nodes in the first visible layer.
6. The method as recited in claim 1, further comprising:
  - responsive to user input, extracting a second set of musical characteristics from a second input musical piece;
  - inputting the second set of musical characteristics together with the first set of musical characteristics as the input vector into the first set of nodes in the first visible layer of the unsupervised neural net; and
  - wherein the perturbed input vector is changed so that the first input musical piece has a greater effect on the output musical piece than the second input musical piece.
7. An apparatus, comprising:
  - a processor;
  - computer memory holding computer program instructions executed by the processor for generating a musical composition based on user input, the computer program instructions comprising:
    - program code operative to extract a first set of musical characteristics from a first input musical piece;
    - program code operative to prepare the first set of musical characteristics as an input vector into an unsupervised neural net comprised of a plurality of computing layers, wherein each computing layer is composed of a set of nodes, wherein the input vector is prepared by perturbing the first set of musical characteristics according to a user intent expressed in the user input to create a perturbed input vector;
    - program code operative to provide the perturbed input vector into a first set of nodes in a first visible layer of the unsupervised neural net;

- program code operative to use the unsupervised neural net using the perturbed input vector to calculate an output vector from a higher set of nodes; and
  - program code operative to use the output vector to create an output musical piece.
8. The apparatus as recited in claim 7, wherein the plurality of computing layers comprise a plurality of Restricted Boltzmann Machines (RBM).
9. The apparatus as recited in claim 7, wherein the user intent is selected from the group consisting of a mood, a genre of music and an activity to be performed while listening to the output musical piece.
10. The apparatus as recited in claim 7, wherein the computer program instructions further comprise program code operative to direct a selection of rule to insert a set of pitches from a key signature associated with the user intent into the first visible layer.
11. The apparatus as recited in claim 7, wherein the computer program instructions further comprise:
  - program code operative to extracting a second set of musical characteristics from a second input musical piece;
  - program code operative to input the second set of musical characteristics together with the first set of musical characteristics as the input vector into the first set of nodes in the first visible layer of the unsupervised neural net; and
  - program code operative to change the perturbed input vector so that the first input musical piece has a greater effect on the output musical piece than the second input musical piece.
12. A computer program product in a non-transitory computer readable medium for use in a data processing system, the computer program product holding computer program instructions which, when executed by the data processing system, for generating a musical composition based on user input, the computer program instructions comprising:
  - program code operative to extract a first set of musical characteristics from a first input musical piece;
  - program code operative to prepare the first set of musical characteristics as an input vector into an unsupervised neural net comprised of a plurality of computing layers, wherein each computing layer is composed of a set of nodes, wherein the input vector is prepared by perturbing the first set of musical characteristics according to a user intent expressed in the user input to create a perturbed input vector;
  - program code operative to provide the perturbed input vector into a first set of nodes in a first visible layer of the unsupervised neural net;
  - program code operative to use the unsupervised neural net using the perturbed input vector to calculate an output vector from a higher set of nodes; and
  - program code operative to use the output vector to create an output musical piece.
13. The computer program product as recited in claim 12, wherein the user intent is selected from the group consisting of a mood, a genre of music and an activity to be performed while listening to the output musical piece.
14. The computer program product as recited in claim 12, wherein the computer program instructions further comprise program code operative to direct a selection of rule to insert a set of pitches from a key signature associated with the user intent into the first visible layer.

15. The computer program product as recited in claim 12, wherein the computer program instructions further comprise:

program code operative to extracting a second set of musical characteristics from a second input musical 5 piece;

program code operative to input the second set of musical characteristics together with the first set of musical characteristics as the input vector into the first set of nodes in the first visible layer of the unsupervised 10 neural net; and

program code operative to change the perturbed input vector so that the first input musical piece has a greater effect on the output musical piece than the second input musical piece. 15

16. The method as recited in claim 1, further comprising: receiving a user request for a plurality of output musical pieces; and

using a plurality of output vectors, each output vector from a different higher level within the unsupervised 20 neural net.

17. The method as recited in claim 4, wherein operating the unsupervised neural net using the perturbed input vector trains Restricted Boltzmann Machines using a contrastive divergence process. 25

\* \* \* \* \*