

M. LEVIN.
 TUMBLER WASHER.
 APPLICATION FILED APR. 22, 1910.

1,002,714.

Patented Sept. 5, 1911.

2 SHEETS-SHEET 1.

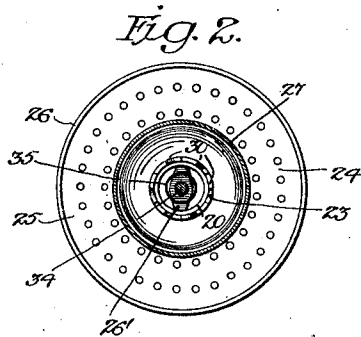
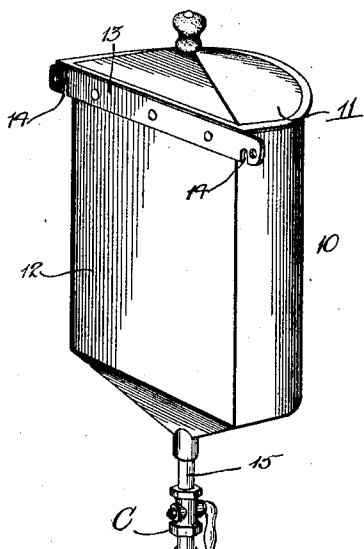
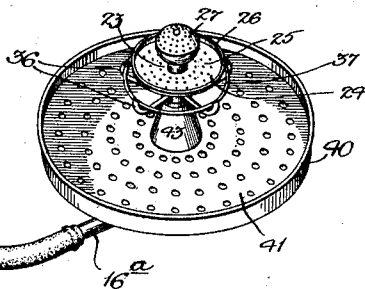

Fig. 1.



Witnesses:-
 Frank W. Remson
 Hildur C. Peterson

Inventor:-
 Max Levin

By:- Frazerbach
 Atty.

M. LEVIN.
 TUMBLER WASHER.
 APPLICATION FILED APR. 22, 1910.

1,002,714.

Patented Sept. 5, 1911.

2 SHEETS—SHEET 2.

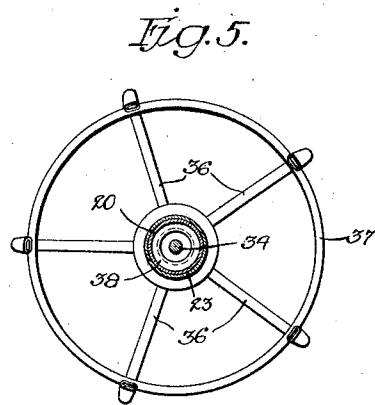
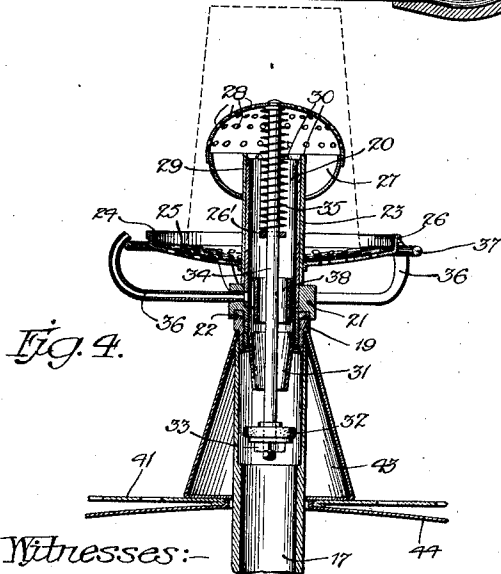
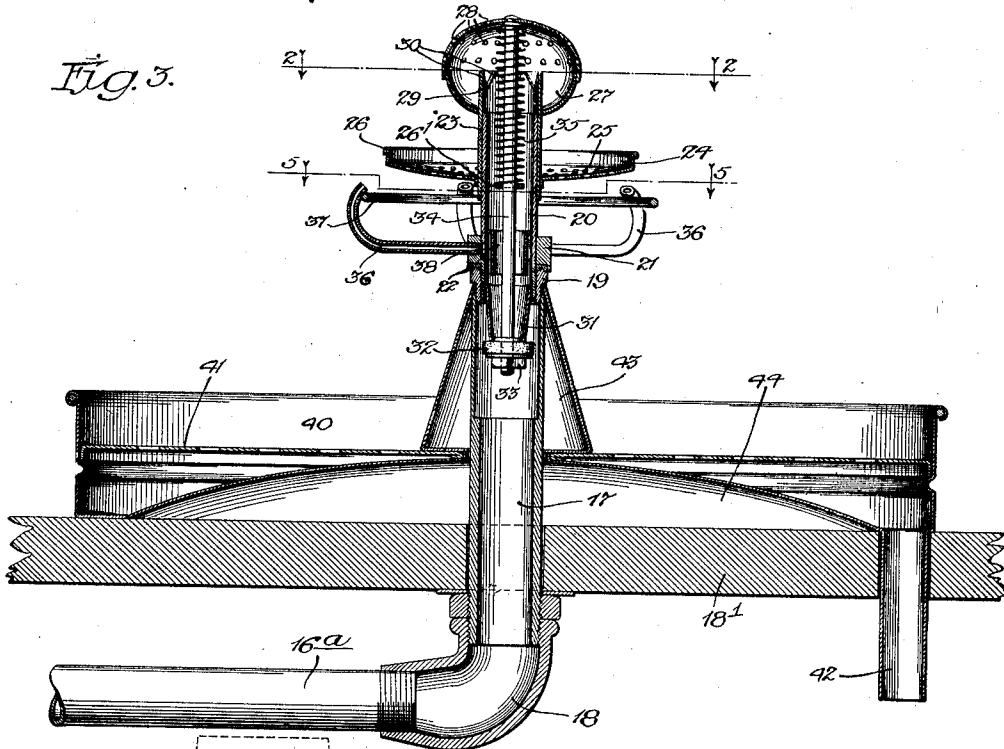

Witnesses:-
 Frank W. Remm
 Eldon C. Peterson

Inventor:-
 Max Levin
 By: Fraegerlach
 Atty.

UNITED STATES PATENT OFFICE.

MAX LEVIN, OF CHICAGO, ILLINOIS.

TUMBLER-WASHER.

1,002,714.

Specification of Letters Patent.

Patented Sept. 5, 1911.

Application filed April 22, 1910. Serial No. 557,042.

To all whom it may concern:

Be it known that I, MAX LEVIN, a resident of Chicago, in the county of Cook and State of Illinois, have invented certain new and useful Improvements in Tumbler-Washers, of which the following is a full, clear, and exact description.

The invention relates to apparatus for washing tumblers and designs to provide a washer of this type which will simultaneously wash the inside and outside of a tumbler by liquid which is not under a comparatively high pressure, so that an elevated tank which may be quickly and readily installed, may be used to supply water to the washer and the necessity of installing permanent pipe-connections connected to the water-supply of service may be avoided.

The invention designs to provide an improved washer which comprises an elevated tank from which the water is supplied under low pressure to a device on which the glass will be held and by which the inside and outside of the tumbler will be simultaneously washed.

The invention further designs to provide a washer of improved construction, which is efficient in operation and may be readily installed in places for use and at any point desired.

The invention consists in the several novel features hereinafter set forth and more particularly defined by claims at the conclusion hereof.

In the drawings: Figure 1 is a perspective of a washer embodying the invention. Fig. 2 is a section on line 2—2 of Fig. 3. Fig. 3 is a vertical section of the washer-nozzle and its connections. Fig. 4 is a section similar to Fig. 3, showing the parts in position assumed when the valve is opened. Fig. 5 is a section taken on line 5—5 of Fig. 3.

The invention designs to provide a washer which will operate efficiently with water from a portable or over-head tank so that it is not necessary to change the plumbing of an establishment in order to provide a supply of water to the washer.

A tank 10 is provided with a removable

cover 11 and has a flat back 12 which is adapted to be sustained by hooks on a wall, a cross bar 13 having notches 14 therein, being secured to the back of the tank, so that it may be readily and conveniently mounted on hooks on a wall. To the bottom of the tank is connected a pipe 15 from which leads a flexible pipe 16 which is connected to a horizontal pipe 16^a which is connected to an upwardly extending pipe 17 by an elbow 18. A cock C controls the flow of water from the tank. Pipe-section 17 is adapted to extend through a table or counter 18', and a ring 19 secured in the upper end of pipe-section 17 is adapted to connect said pipe-section to a pipe-section 20, which is provided at its lower end with a collar 21 having a screw-thread for engaging a screw-thread in collar 19. A gasket 22 is interposed between collars 21 and 19 to provide a water-tight connection between pipe-sections 20 and 17. A pipe 23 is slidably mounted on the upper portion of pipe-section 20 and a glass-holder 24 is secured to the pipe 23. This holder comprises a perforated bottom 25 and a rim 26, and is adapted to receive an inverted tumbler, so that by depressing the same, the holder and pipe 23 may be lowered to operate a valve for controlling the supply of water to the spraying-nozzle. The perforated bottom permits the water which has been sprayed against the inside of the glass to escape on to a collector, as hereinafter set forth. An enlarged or globular spray-nozzle 27 is secured to pipe 23 and extends over the top thereof, being provided with perforations 28 extending upwardly and outwardly, so that substantially the entire inside of a tumbler, and particularly the bottom and sides will be sprayed. The upper end of pipe 23 is extended into the globular spray-head, as at 29 and has its edges notched, as at 30, to direct some of the liquid entering the head laterally to these perforations, which direct the liquid laterally against the sides of the tumbler.

A valve 32 controls the supply of liquid to the spray-head and this valve is operated by the holder 24 and pipe 23, so that by a depression of the holder by a glass, the valve will be opened to cause the tumbler to

be washed. A valve-seat 31 is tapered and secured in the lower end of fixed collar 21. Valve 32 is secured by a nut 33 to the lower end of stem 34 which has its upper end secured to the top of the spray-head 27. A spring 35 is interposed between the spray-head, and an abutment 26' secured in pipe-section 20 to hold the valve normally closed and to raise the tumbler-holder 24 and the nozzle when a glass is removed from the holder. Provision is also made for washing the outside of the glass, while the inside is being sprayed and for this purpose a series of pipes 36 extend outwardly from collar 21 at the lower end of the fixed pipe-section 20 and have their outer ends curved upwardly and their terminals curved inwardly and upwardly, to direct the water angularly and upwardly and inwardly against the glass on the holder when the latter is depressed. By directing the water-jets in these directions, the water will be forced to the top of the glass and cause substantially the entire side of the glass to be sprayed. The upper ends of pipes 36 are connected and secured together by a ring 37. A thimble 38 is secured in pipe-section 20 has a flange at its upper end and has a wall which is disposed inwardly of the wall of pipe 20 adjacent the point where the pipes 36 communicate with the interior of said pipe, so that this thimble will serve as a divider for the water, whereby some of it will be directed to the pipes 36 and the remainder will be directed upwardly through pipe 20 to the spray-head for the inside of the glass.

From the mechanism thus described, it will be seen that when a glass is placed on the holder 24 and depressed, pipe 23, head 27 and valve-stem 34 will be depressed, valve 32 will be opened, causing the water in pipe 17 to pass through valve-seat 31 and part of it around thimble 38, through pipes 36, the upper ends of which will direct the water angularly, upwardly and inwardly against the sides of the glass. The rest of the water will pass through the center of thimble 38, and pipe 20 into the spray-head 27 and the water will issue in divided currents or jets from said spray-head. Thus, the inside and outside of the glass will be simultaneously washed.

On the table or counter 18' and around the inlet 17, a tray 40 is mounted in which the water from the washer will be collected, being disposed below it. A perforated plate 41 is held in tray 40 and a discharge-pipe 42 conducts water from the tray to a pail or suitable receptacle placed beneath it to receive the water from the tray. A conoidal deflector 43 is secured to inlet-pipe 17 and extends outwardly and downwardly from its upper end to the perforated plate 41 and directs the water passing downwardly from the central portion of the holder 24 out-

wardly, so that it will not leak through the central opening in the tray, through which pipe-section 17 passes. The bottom 44 of tray 40 is preferably convex to direct the water therein outwardly to the discharge pipe 42. If desired, the table may be omitted.

As a result of the construction set forth, water which is under pressure from an overhead tank will be forced through the spray-nozzle and pipes to wash the inside and outside of the glass.

The apparatus may be readily installed without the necessity of connecting the washer to the service pipe for water, because a low pressure is sufficient to cause water to efficiently rinse and wash the glass.

The invention is not to be understood as restricted to the details shown and described, since these may be modified within the scope of the appended claims, without departing from the spirit and scope of the invention.

Having thus described the invention, what I claim as new and desire to secure by Letters Patent, is:

1. The combination of an upwardly extending water-pipe, a valve in said pipe, a spray-head at the upper end of said pipe, a series of jet-pipes for the outside of the glass communicating with said pipe above the valve, a divider-sleeve in said pipe for directing some of the water into the spray-pipes, and a tumbler-holder connected to said valve and head.
2. The combination of an upwardly extending water-pipe, a valve in said pipe, a sleeve slidably mounted on the upper end of said pipe, a spray-head connected to said sleeve, said sleeve extending into the head and having notches therein for dividing the water, and a holder secured to said sleeve and operatively connected to said valve.
3. The combination of an upwardly extending water-pipe, a tray around said pipe, a deflector above the tray and around said pipe for directing the water outwardly from the pipe, said pipe extending through the tray, a spray-head connected to said pipe, and a valve for controlling the flow of water to the spray-head.
4. The combination of an upwardly extending water-pipe, a tray around said pipe, a deflector above the tray and around said pipe for directing the water outwardly from the pipe, said pipe extending through the tray, a spray-head connected to said pipe, a glass holder connected to the spray-head, and a valve operatively connected to said head and holder.
5. The combination of an upwardly extending pipe-section, an upper pipe-section connected to said section, a valve-seat at the lower end of said upper pipe-section,

a spray-head slidably mounted on said pipe-section, a valve engaging said seat, a valve-stem extending upwardly from the seat and secured to the spray-head, a spring for holding said valve normally closed, a series of spray-pipes for the outside of a glass fixed to said pipe-section, and a divider-sleeve

above the valve and in said upper pipe-section.

MAX LEVIN.

Witnesses:

HILDUR C. PETERSEN,
FRANK W. BEMIS.

Copies of this patent may be obtained for five cents each, by addressing the "Commissioner of Patents, Washington, D. C."
