



Europäisches Patentamt
European Patent Office
Office européen des brevets



Publication number: **0 477 475 A2**

EUROPEAN PATENT APPLICATION

Application number: **91110116.0**

Int. Cl.⁵: **F25B 47/02, F25B 5/04**

Date of filing: **20.06.91**

Priority: **28.09.90 IT 4169990**

Inventor: **Casanova, Giuseppe**
Via Cavassico Inferiore, 149
I-32028 Trichiana (Belluno)(IT)

Date of publication of application:
01.04.92 Bulletin 92/14

Designated Contracting States:
AT BE CH DE DK ES FR GB GR LI LU NL SE

Representative: **Cantaluppi, Stefano et al**
c/o Jacobacci-Casetta & Perani S.p.A. Via
Berchet 9
I-35131 Padova(IT)

Applicant: **COSTAN S.P.A.**
Via degli Alpini 14
I-32020 Limana(Belluno)(IT)

An improved refrigeration circuit and method of de-frosting it.

A refrigeration circuit (1) intended for incorporation to refrigerated display counters (2) comprises a compressor (3), a series of first and second evaporators (10,13), and means (15) of de-frosting the evaporators

which include a bypass connection (17) between the compressor (3) outlet and the second evaporator (13) inlet.

FIG. 1

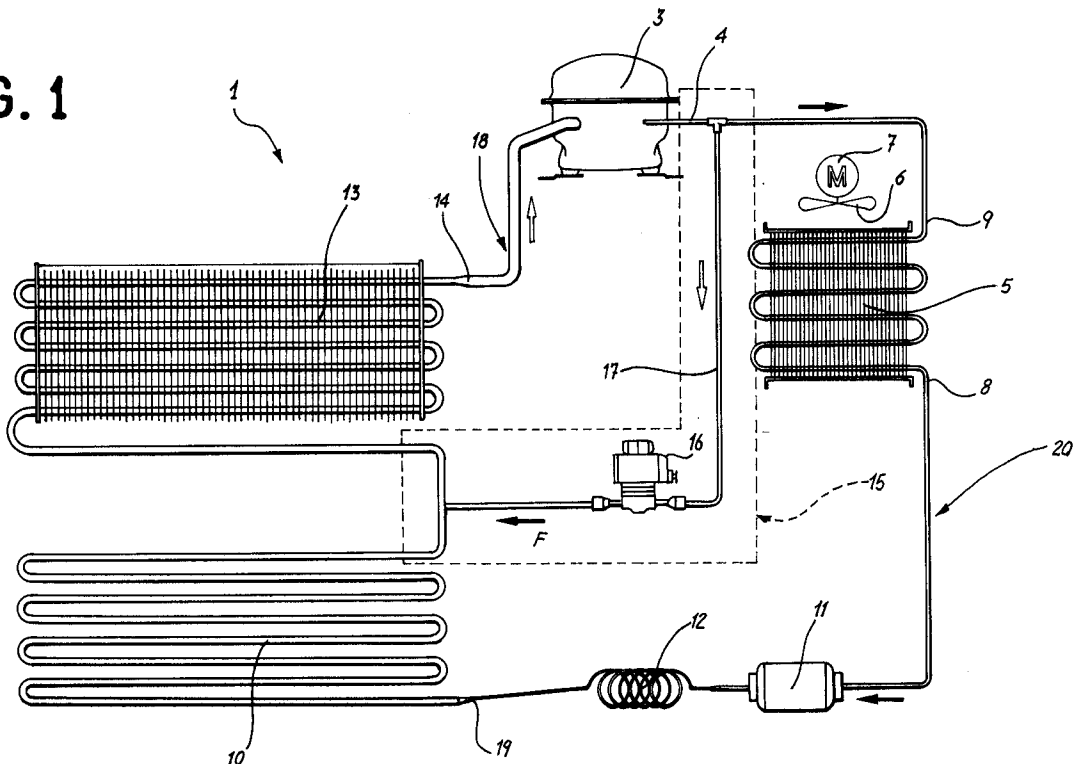

EP 0 477 475 A2

This invention relates to an improved refrigeration circuit, particularly of the type which is incorporated to refrigerated display counters and comprises a refrigerating gas compressor, a condenser, a first evaporator and at least one second evaporator connected in series to each other, and evaporator de-frosting means.

The invention also relates to a refrigerated counter having a refrigeration circuit which comprises a series of a first evaporator operating in conductive heat transfer with one or more walls of the counter and with a second finned or convective transfer evaporator which, in operation of the refrigerated counter, is swept by a forced air flow to enhance the convective heat transfer.

The invention further relates to a method of de-frosting such circuit and counter.

It is well known that in the specific technical field of this invention it becomes necessary to periodically de-frost the refrigerated counter.

This operation is usually performed through heater means incorporated to the counter itself.

For instance, a known technical solution for meeting this demand provides for the conveying of all the "hot" refrigerating gas available at the compressor outlet through both evaporators, bypassing the condenser.

Owing to this technique temporarily eliminating the condensation and evaporation steps, the circuit ceases to operate in accord with a refrigeration cycle throughout the duration of the de-frosting step. It follows that the heat available to de-frost is that deriving from the energy dissipated by the compressor. In addition, both evaporators are de-frosted, and this unavoidably involves a longer de-frosting time and longer pickup time for the refrigeration cycle to recover its running temperature.

Another drawback of this de-frosting technique comes from that the first evaporator is usually installed on the bottom of the refrigerated counter, in direct contact with the products to be preserved, which accordingly undergo undesired heating while de-frosting.

Further, it has been observed that the compressor operates, during the de-frosting step, outside its design thermal range, resulting in overheating and shortened life of the same.

The technical problem addressed by this invention is to provide a refrigeration circuit having such structural and functional characteristics as to overcome the above-mentioned drawbacks with which the prior art is beset.

The solutive idea on which the invention stands consists of tapping off a fraction of the "hot" refrigerating gas downstream from the compressor, while the remainder is allowed to carry on the refrigeration cycle, and admixing it, upstream of the second evaporator, to the "cool" refrigerating gas

from the first evaporator.

In this way, at least some of the refrigerating gas is subjected to a normal refrigeration cycle even during the de-frosting step, which results in improved overall efficiency of the circuit.

Based on this idea, the aforementioned technical problem is solved by a circuit as indicated being characterized in that said means comprise a bypass connection between the compressor outlet and the inlet to the second evaporator.

In a preferred embodiment, a pre-set solenoid valve is provided in the said bypass connection.

This technical problem is also solved by a method of de-frosting a refrigeration circuit comprising a refrigerating gas compressor, a condenser, and a first evaporator and at least one second evaporator connected serially to each other, characterized by tapping off some of the refrigerating gas downstream from the compressor and supplying the second evaporator with a mixture of said gas and gas exiting the first evaporator.

The features and advantages of the refrigeration circuit according to the invention will be apparent from the following detailed description of an embodiment thereof, shown by way of illustration and not of limitation in the accompanying drawings.

In the drawings:

Figure 1 is a schematic view of the refrigeration circuit according to the invention;

Figure 2 is a cross-sectional view of a refrigerated display counter incorporating the refrigeration circuit of this invention.

With reference to these drawing figures, generally and schematically shown at 1 is a refrigeration circuit embodying this invention and being intended for installation in a refrigerated display counter 2 of which the remaining structural elements are conventional.

The circuit 1 utilizes the properties of a suitable conventional refrigerating fluid, such as freon, which forms the working fluid through the operation cycles to be described.

The circuit 1 comprises a compressor 3 having an outlet 4 in fluid communication with the inlet 9 of a condenser 5. Said condenser is cooled by a fan 6 driven by a motor 7.

The condenser has an outlet 8 connected to the inlet 19 of a first evaporator 10 through a series of a de-watering filter 11 and a capillary 12.

The evaporator 10 is placed in substantial contact with a vat-like wall 25 of the counter 2 intended to contain the products to be preserved, in an essentially conductive heat transfer relationship with that wall 25. This first evaporator 10 is connected serially to a second, finned evaporator 13 which is in a substantially convective heat transfer relationship with its environment.

This second evaporator has an outlet 14 con-

nected to the inlet of the compressor 3.

The circuit 1 comprises de-frosting means 15 for the evaporator 13.

Such means 15 comprise a one-way bypass connection 17 between the outlet 4 of the compressor 3 and the inlet of the second evaporator 13.

A solenoid valve 16, which is pre-set at a selected flow rate of the refrigerating fluid below the overall flow rate at the delivery outlet of the compressor 3, is provided in the connection 17.

By the provision of the connection 17, the circuit 1 is essentially composed of a pair of circuit links 18, 20. The first link 18 comprises the compressor 3, valve 16, and second evaporator 13; and the second link 20 includes, in turn, the compressor 3, condenser 5, and series of the evaporators 10, 13.

When it is desired to start de-frosting the counter 2, the valve 16 is operated to an open position, and some of the fluid exiting the compressor 3 is tapped off the second circuit link 20 and directed into the second evaporator 13, over the connection 17.

Thus, the second evaporator 13 is supplied with a comparatively warm fluid consisting of the fluid exiting the first evaporator 10 and the fluid delivered from the compressor 3, mixed together.

Nonetheless, the refrigeration cycle through the link 20 is completed, albeit at a reduced rate, by the remainder of the refrigerating fluid which still flows through the condenser 5.

Thus, the invention solves the aforementioned technical problem in a cost-efficient and effective manner.

A major advantage of the refrigeration circuit of this invention is that during the step of de-frosting the second evaporator, at least some of the refrigerating fluid is caused to undergo a normal refrigeration cycle, thereby enhancing the overall efficiency of the circuit.

In this way, the first evaporator, that is the one directly contacting the products preserved in the refrigerated counter, will undergo no heating. This fact, besides affording quicker restoration of the cooling cycle, also prevents the products preserved under the counter from becoming heated and possibly damaged while de-frosting.

Claims

1. An improved refrigeration circuit, particularly of the type which is incorporated to refrigerated display counters and comprising a refrigerating gas compressor (3), a condenser (5), a first evaporator and at least one second evaporator (10,13) connected in series to each other, and evaporator de-frosting means, characterized in that said means comprise a by-

pass connection (17) between the compressor (3) outlet and the inlet to the second evaporator (13).

5 2. A refrigeration circuit according to Claim 1, characterized in that provided in said bypass connection (17) is a valve (16) pre-set to a selected gas flow rate below the overall flow rate of said compressor (3).

10 3. A refrigerated counter, characterized in that it incorporates a refrigeration circuit (1) according to either claim 1 or 2.

15 4. A refrigerated counter according to Claim 3, wherein the first evaporator (10) is in conductive heat transfer communication with one or more walls (25) of the counter, and the second evaporator (13) is a finned or convective heat transfer one.

20 5. A method of de-frosting a refrigeration circuit comprising a refrigerating gas compressor, a condenser, and a first evaporator and at least one second evaporator connected serially to each other, characterized by tapping off some of the refrigerating gas downstream from the compressor and supplying the second evaporator with a mixture of said gas and gas exiting the first evaporator.

35

40

45

50

55

FIG. 1

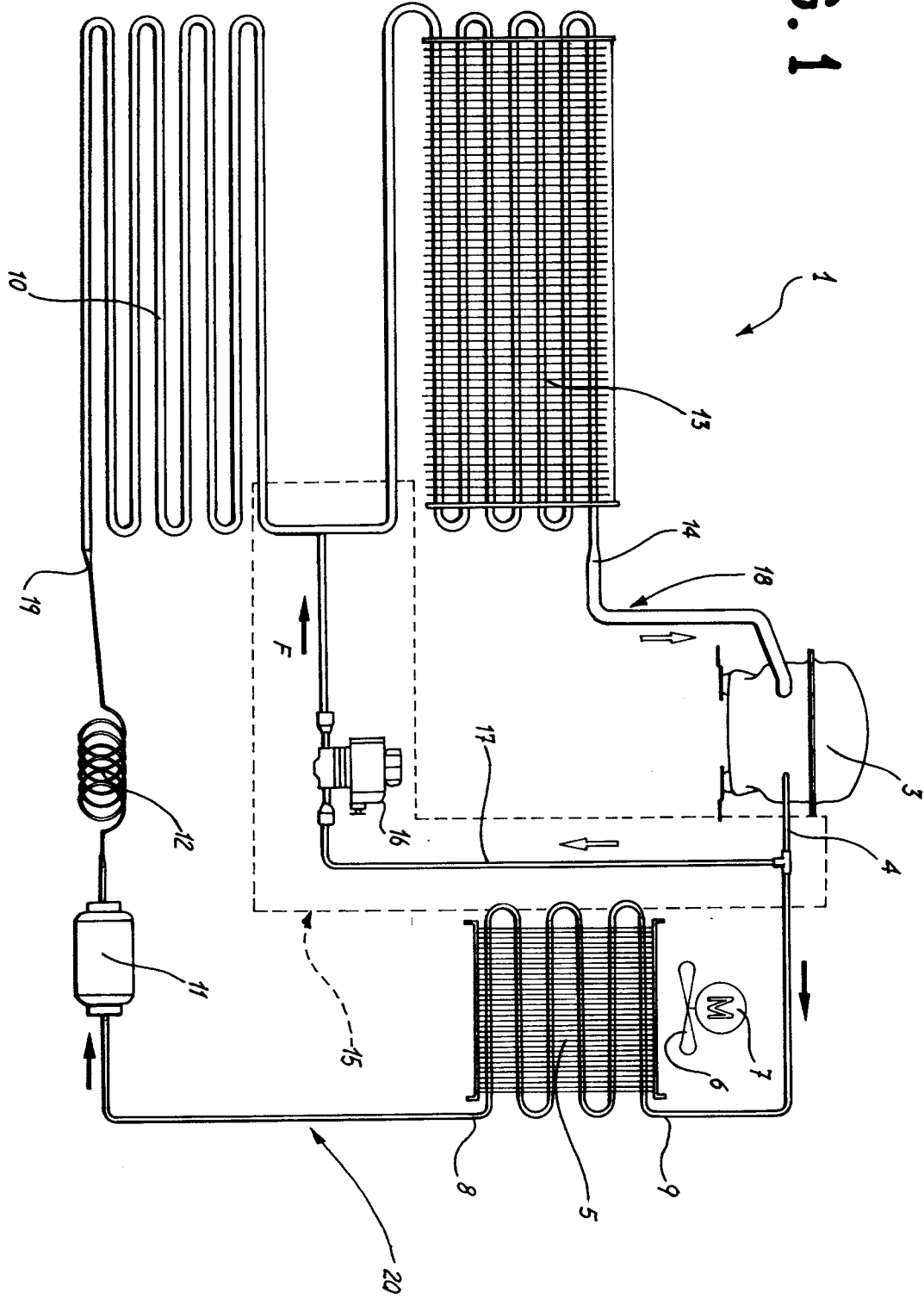

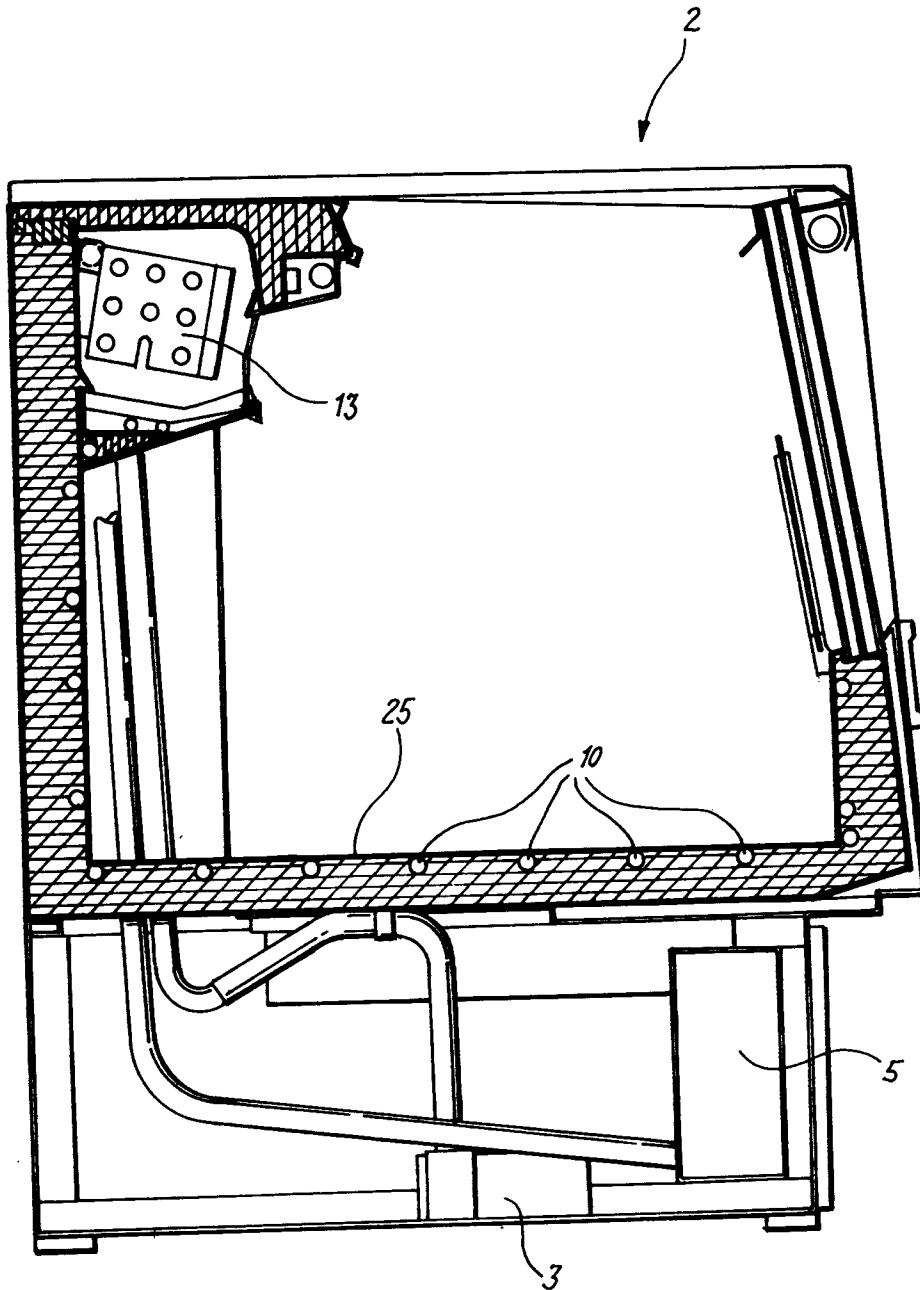

FIG. 2