



US 20150150563A1

(19) **United States**

(12) **Patent Application Publication**
Marchand et al.

(10) **Pub. No.: US 2015/0150563 A1**

(43) **Pub. Date: Jun. 4, 2015**

(54) **FILAMENTARY DEVICES FOR TREATMENT OF VASCULAR DEFECTS**

(60) Provisional application No. 61/050,124, filed on May 2, 2008.

(71) Applicant: **Sequent Medical Inc.**, Aliso Viejo, CA (US)

Publication Classification

(72) Inventors: **Philippe Marchand**, Lake Forest, CA (US); **Brian J. Cox**, Laguna Niguel, CA (US); **Robert F. Rosenbluth**, Laguna Niguel, CA (US)

(51) **Int. Cl.**
A61B 17/12 (2006.01)

(52) **U.S. Cl.**
CPC **A61B 17/12172** (2013.01); **A61B 17/12113** (2013.01); **A61B 17/12145** (2013.01); **A61B 17/12177** (2013.01); **A61B 17/1219** (2013.01); **A61B 17/12118** (2013.01); **A61B 2017/00867** (2013.01)

(21) Appl. No.: **14/577,923**

(22) Filed: **Dec. 19, 2014**

(57) **ABSTRACT**

Related U.S. Application Data

Devices and methods for treatment of a patient's vasculature with some embodiments configured for delivery with a microcatheter for treatment of the cerebral vasculature of a patient. Some embodiments may include a permeable shell configured to occlude blood flow therethrough.

(63) Continuation of application No. 12/434,465, filed on May 1, 2009.

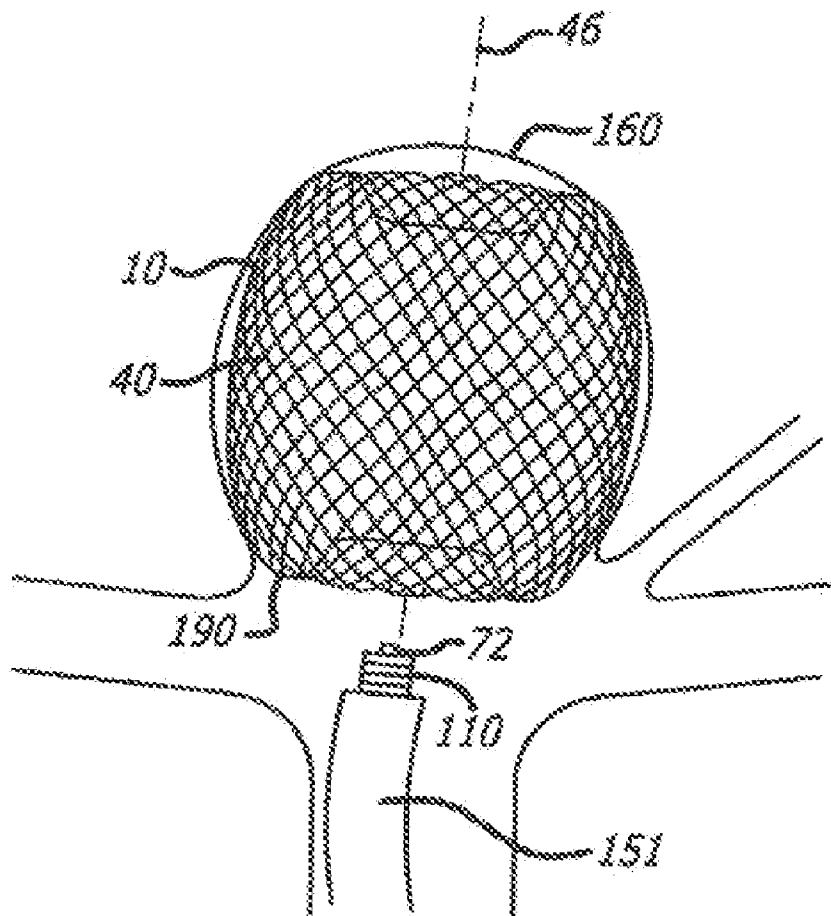

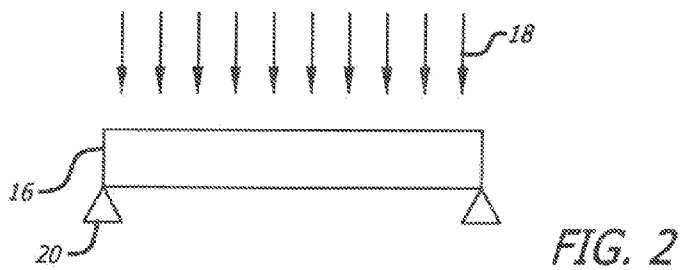
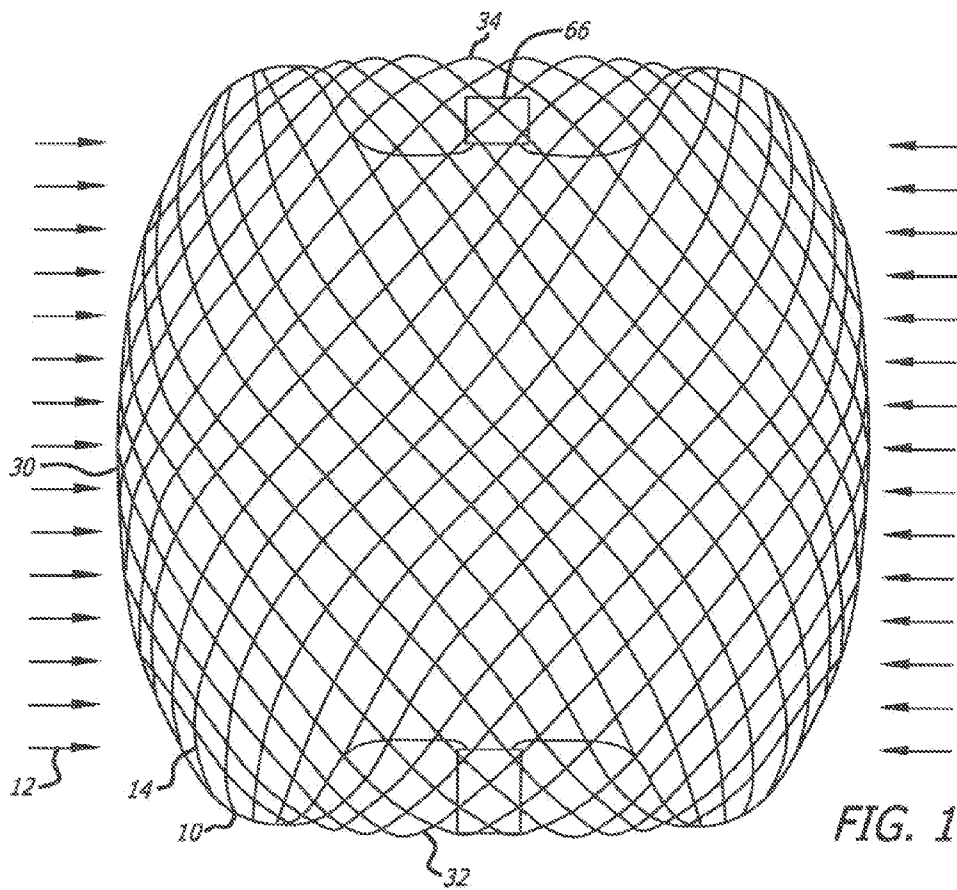

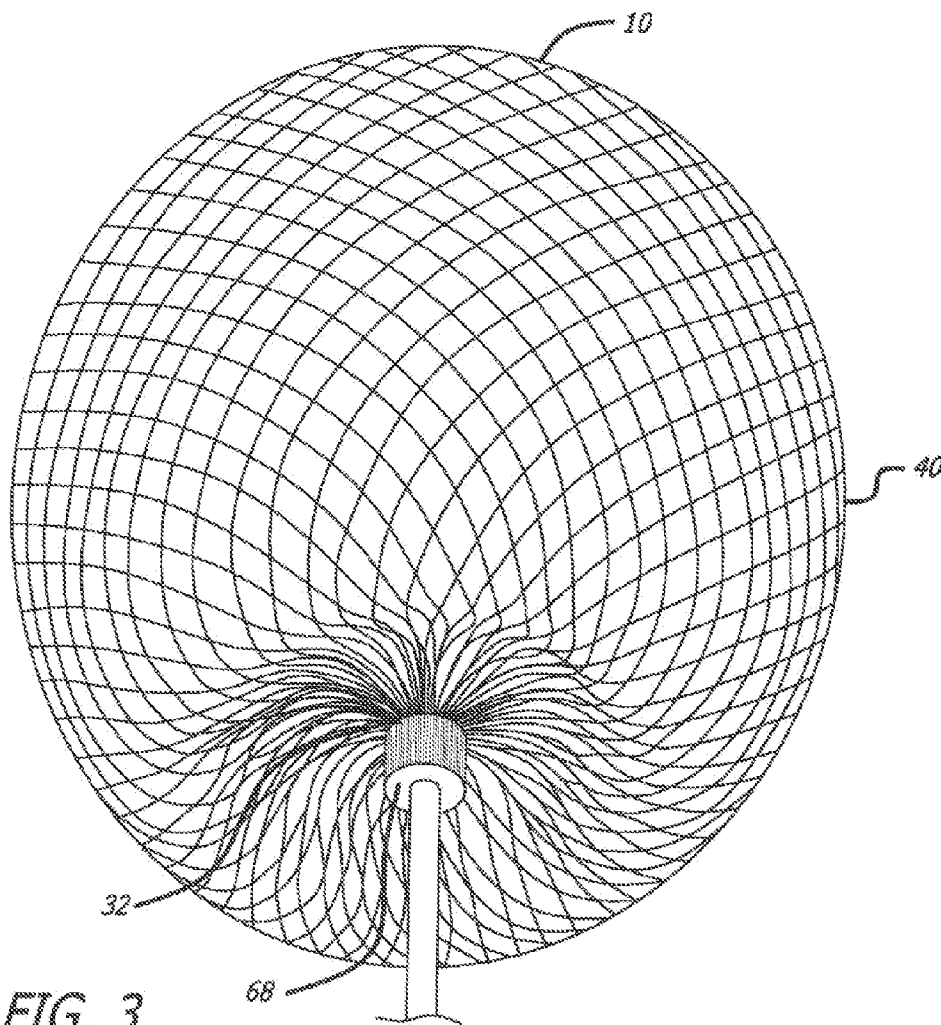

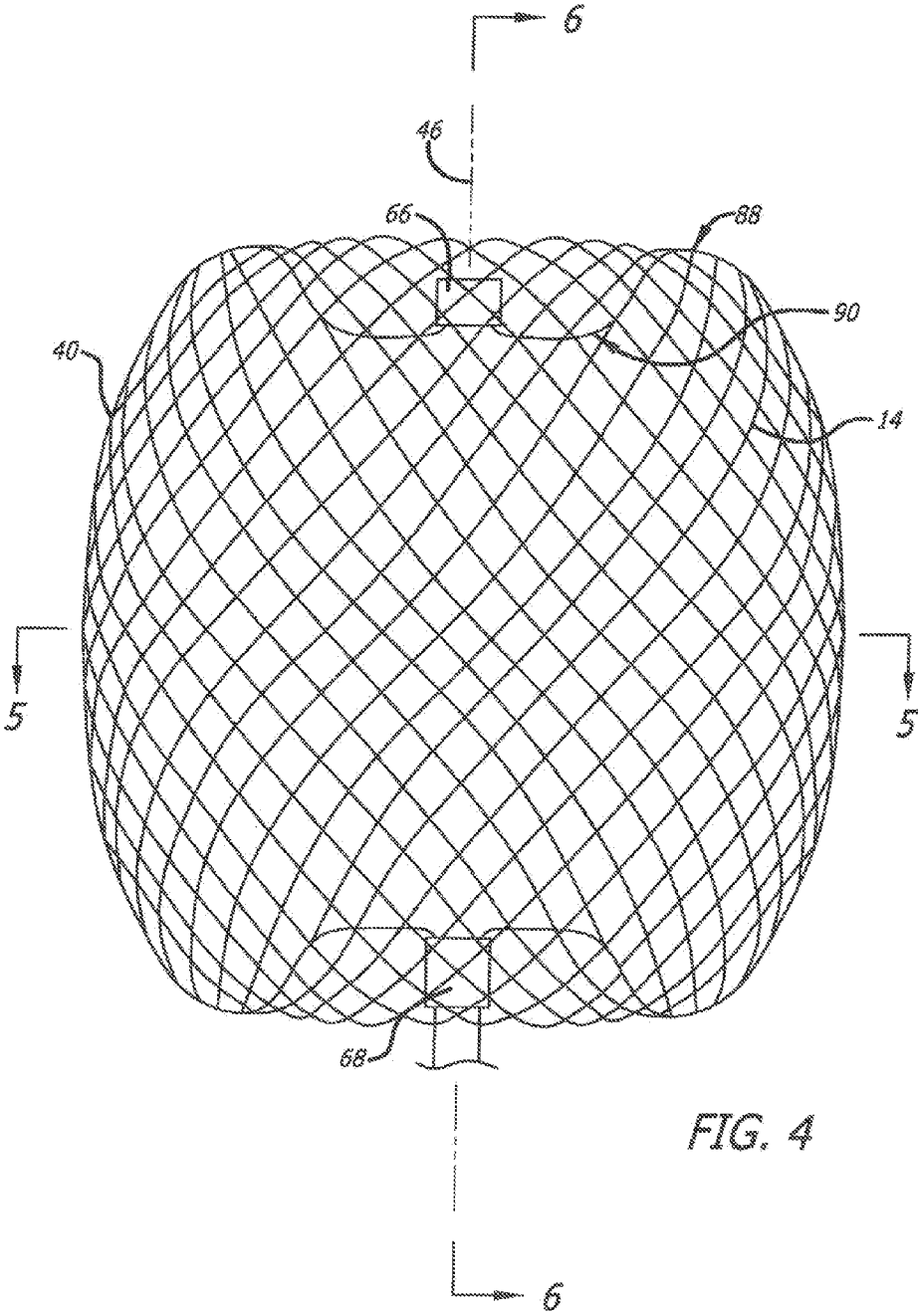

FIG. 4

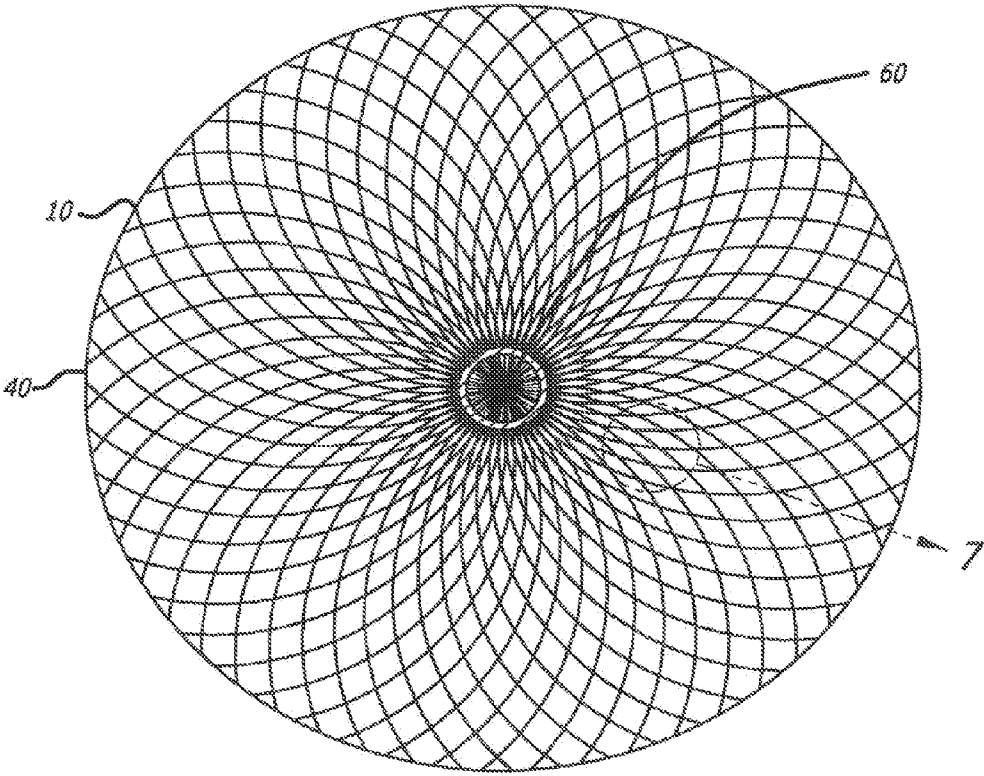

FIG. 5

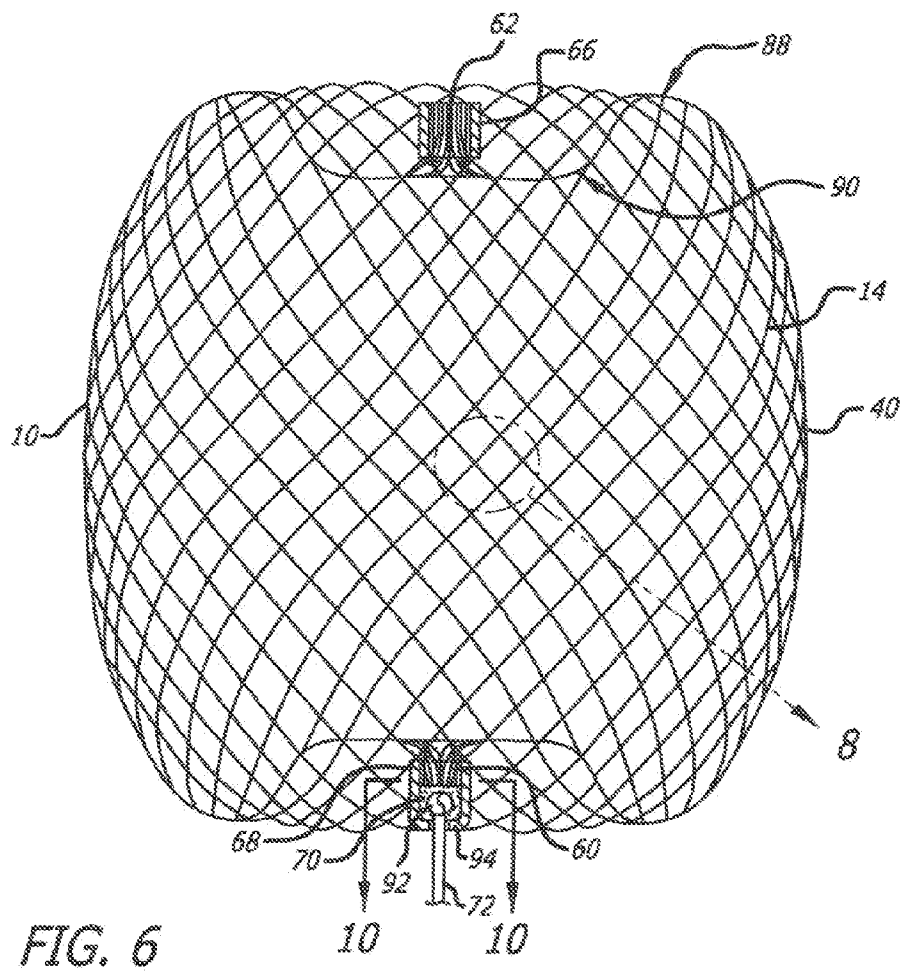
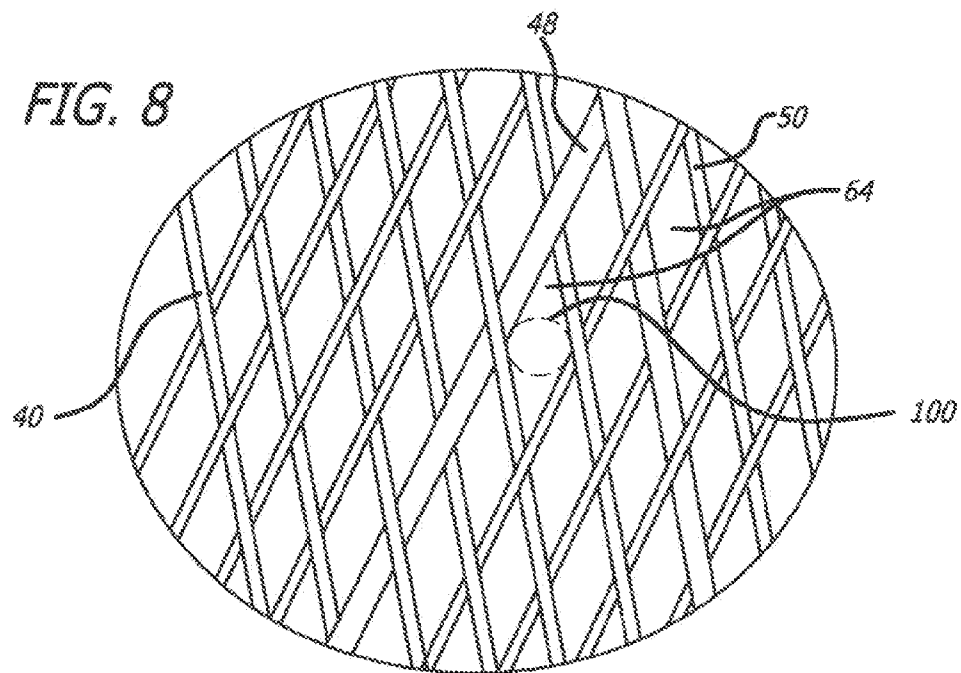
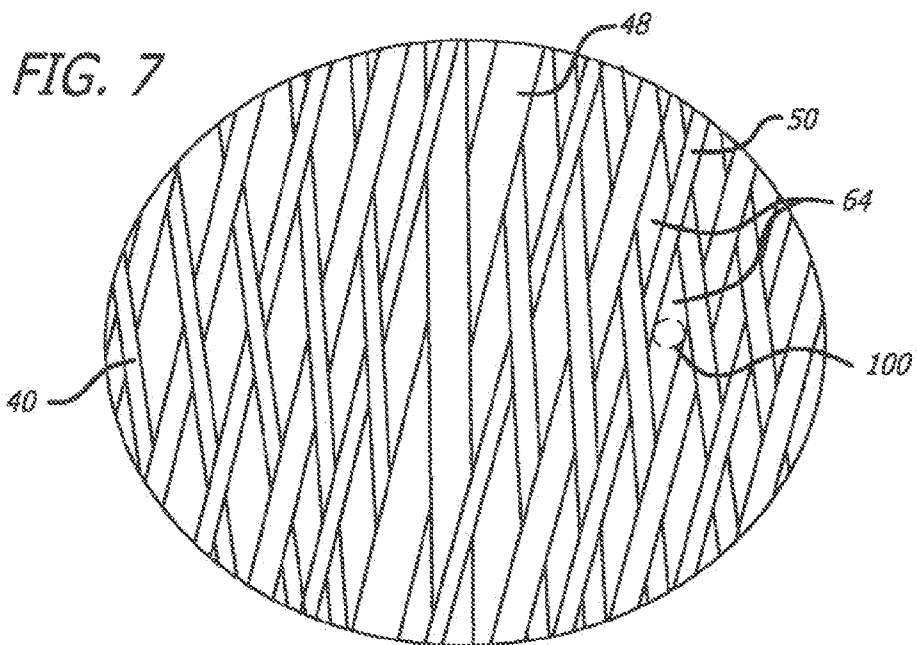

FIG. 6



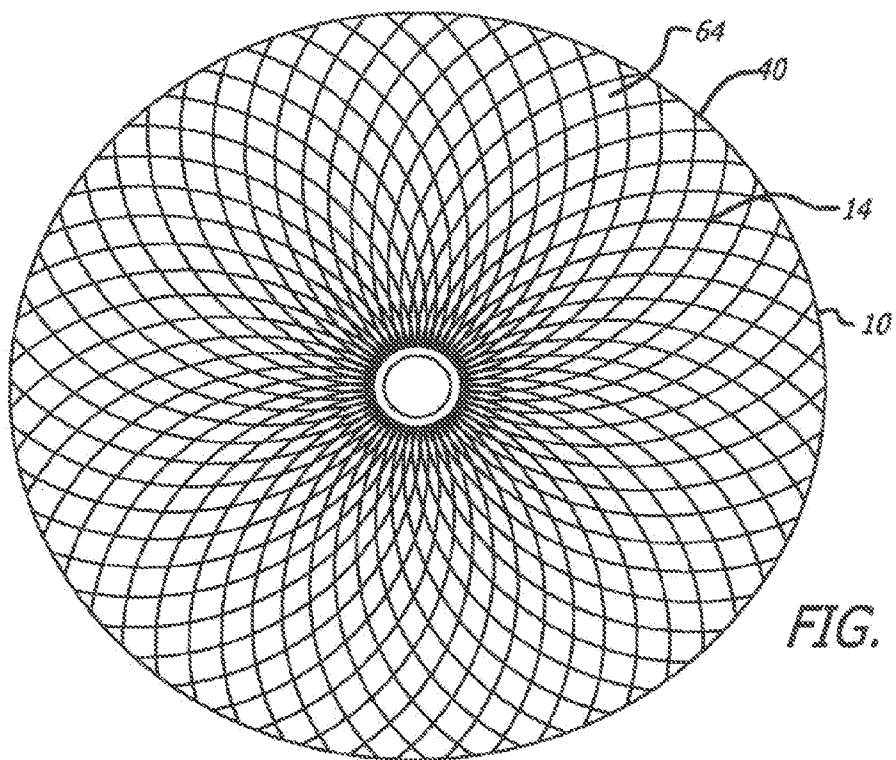

FIG. 9

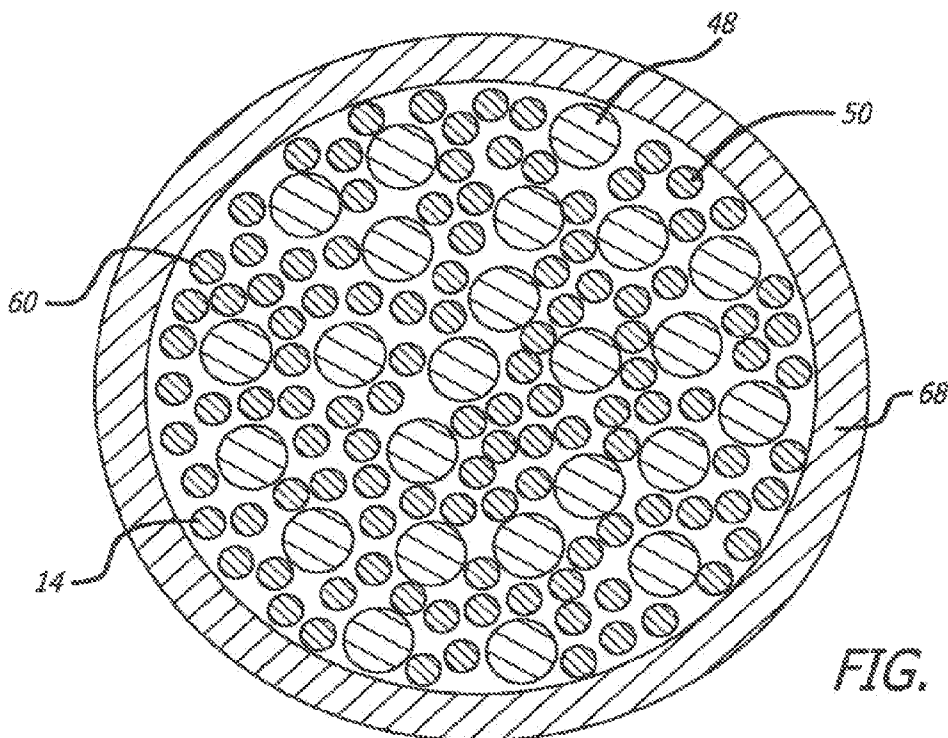

FIG. 10

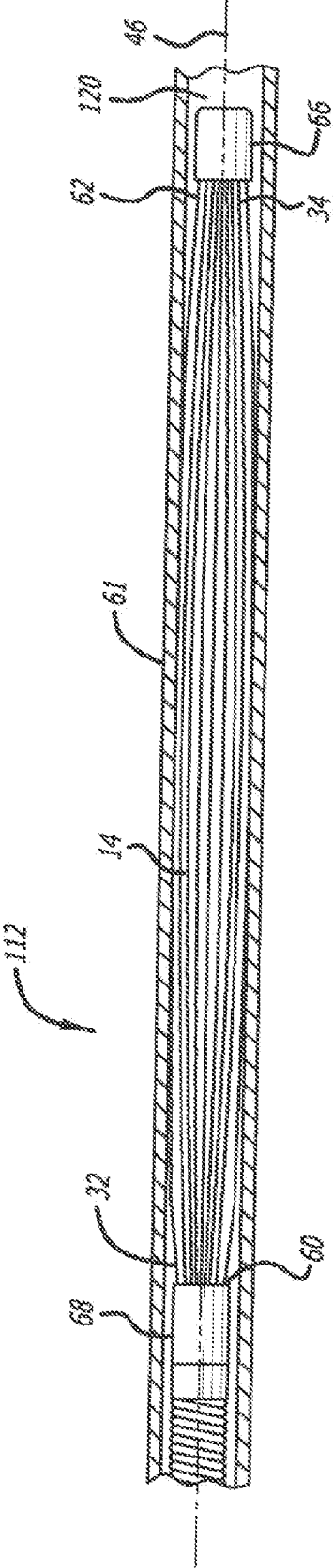
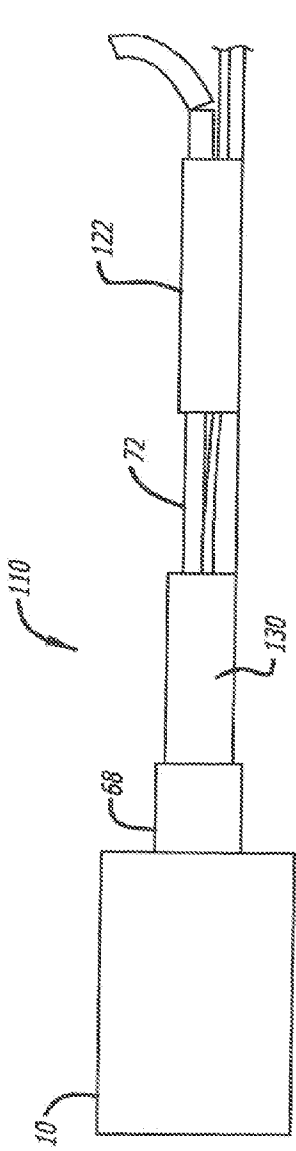
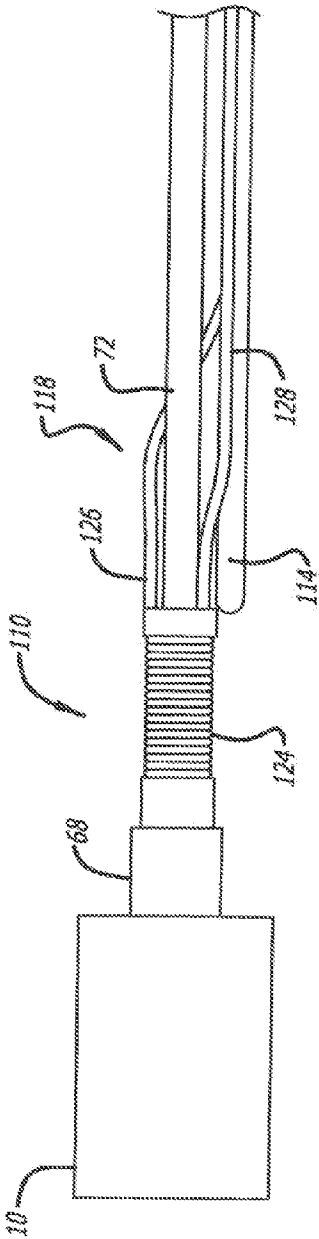

FIG. 11



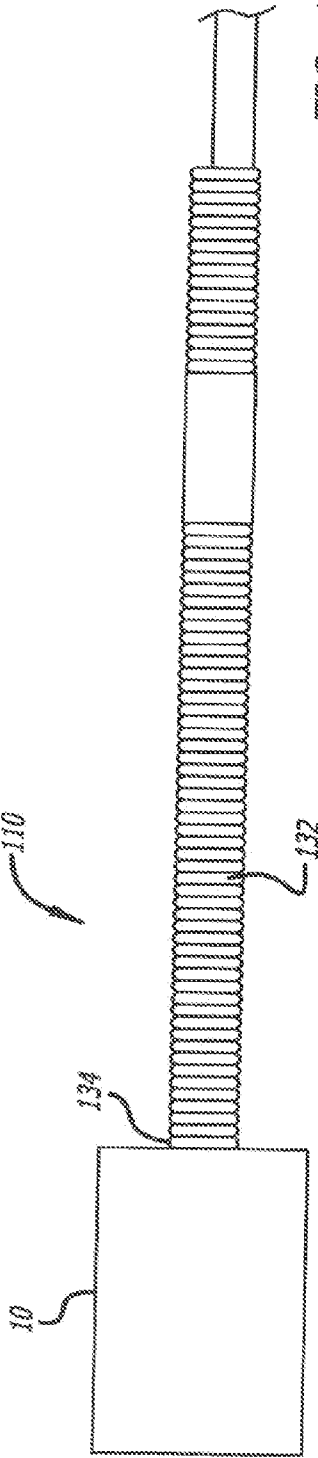

FIG. 14

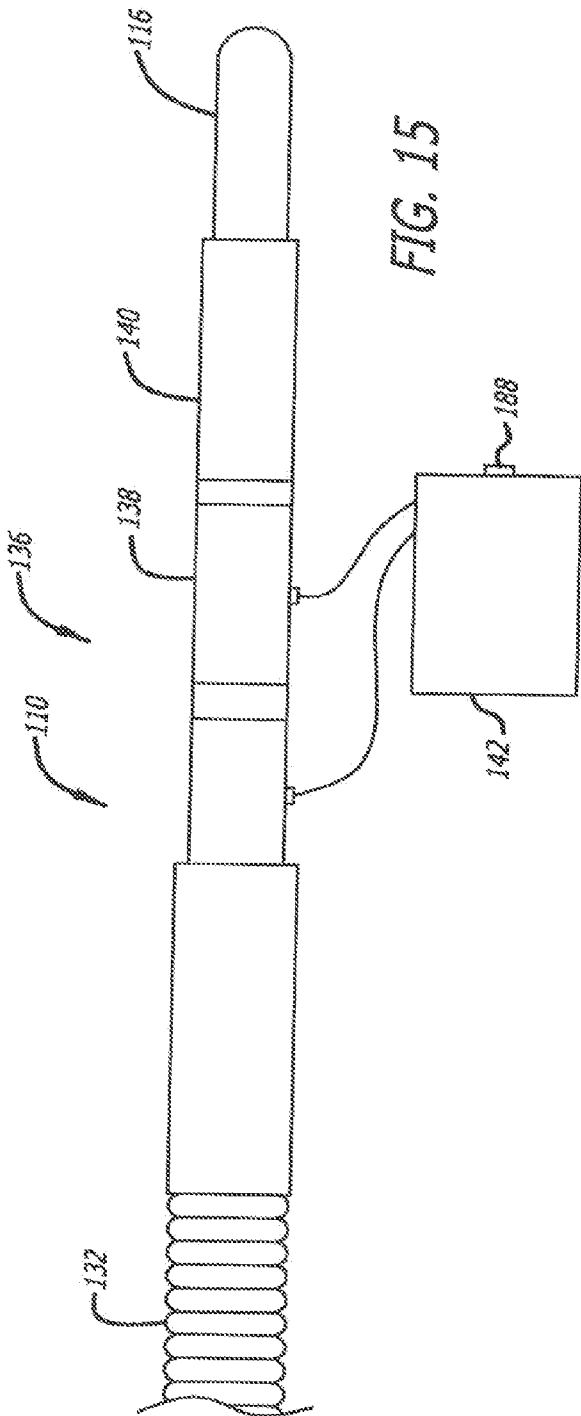

FIG. 15

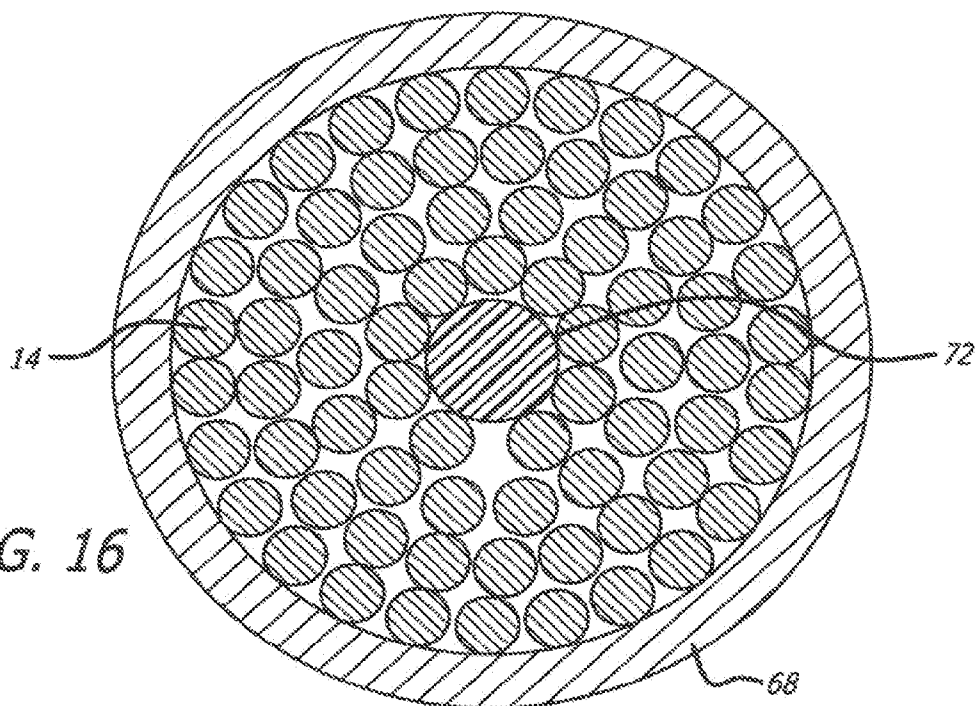

FIG. 16

FIG. 17

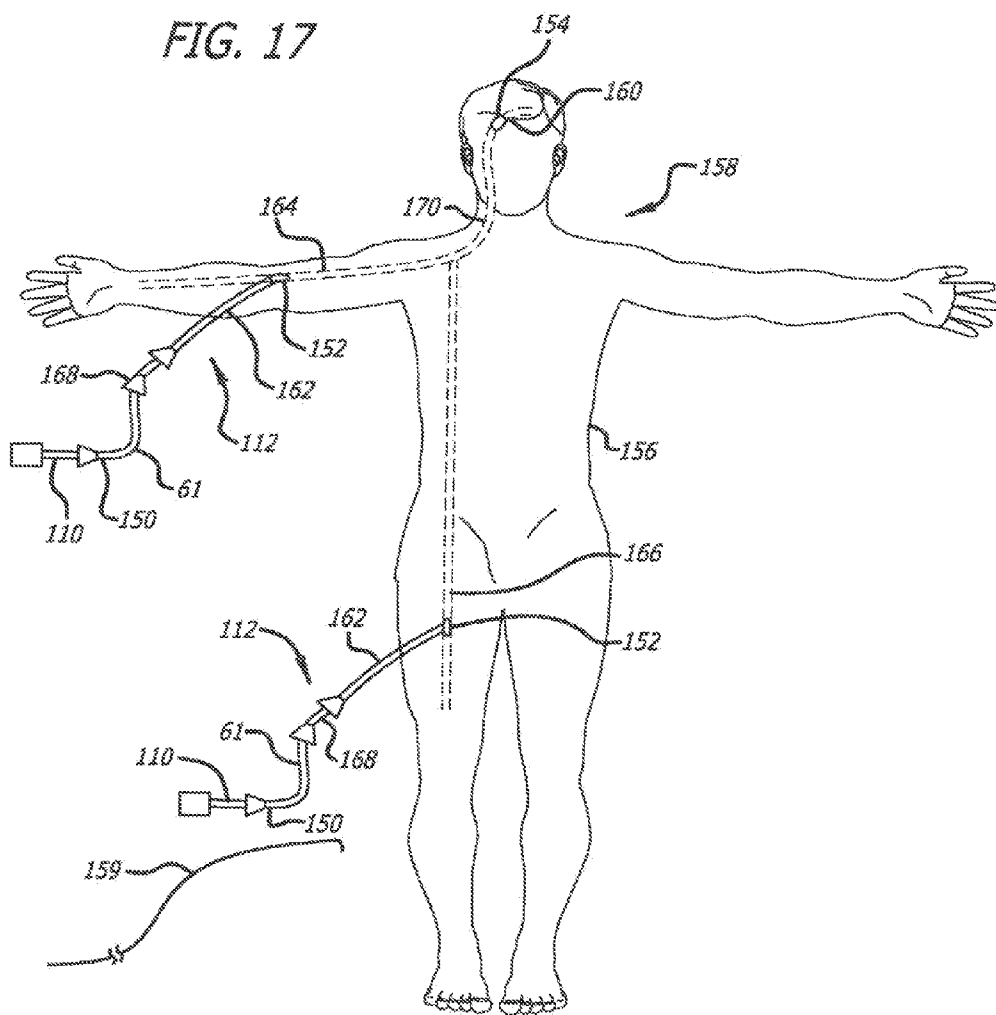

FIG. 18

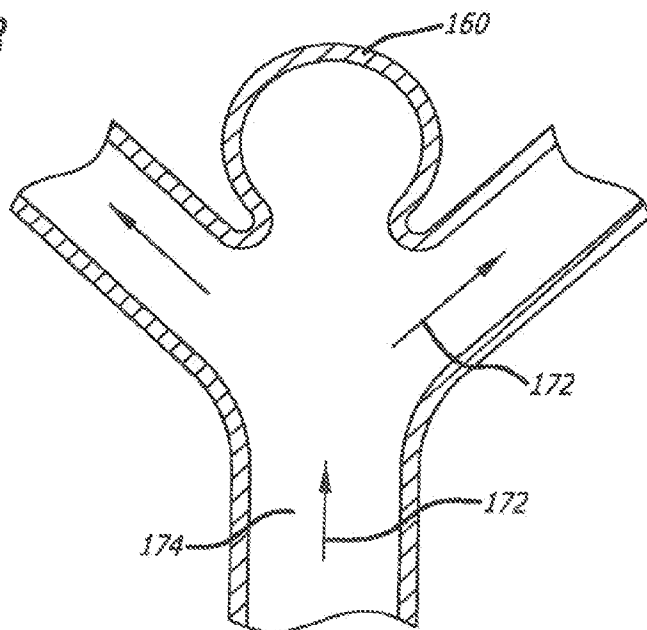
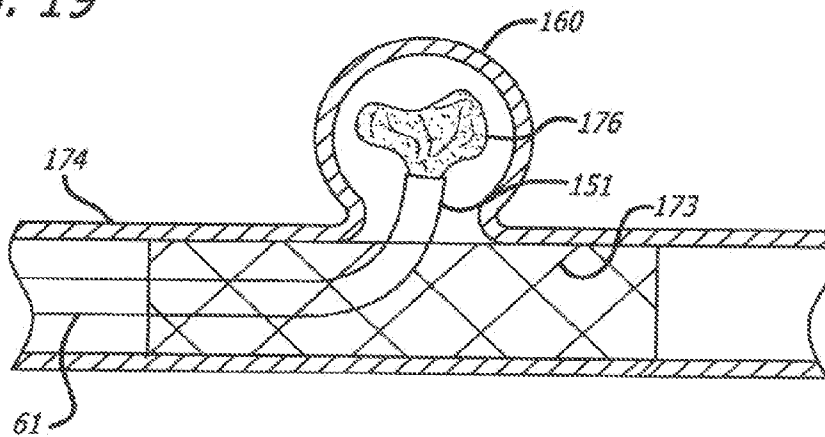

FIG. 19



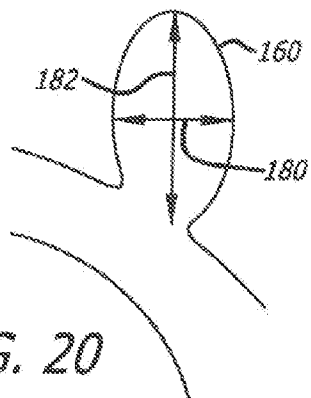

FIG. 20

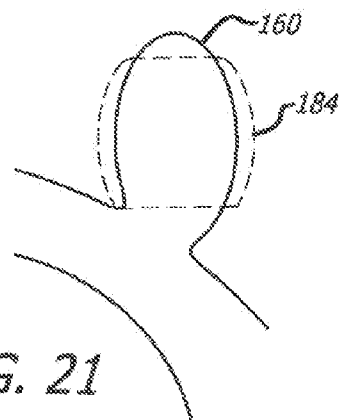

FIG. 21

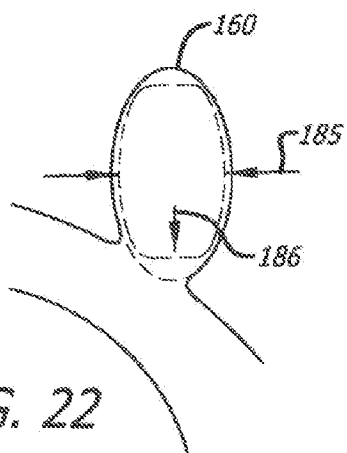

FIG. 22

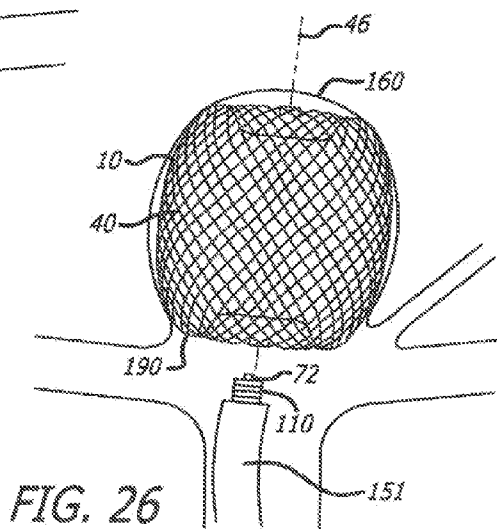
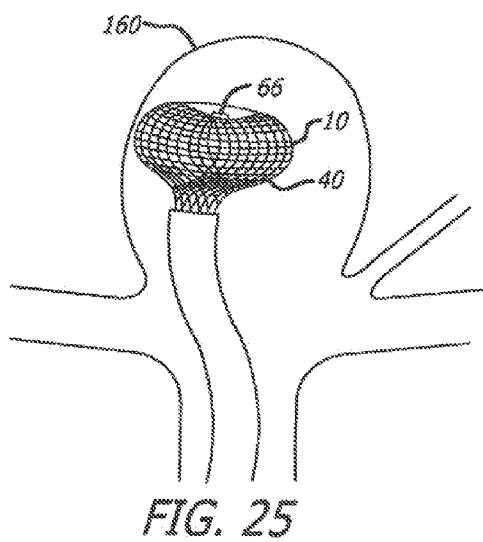
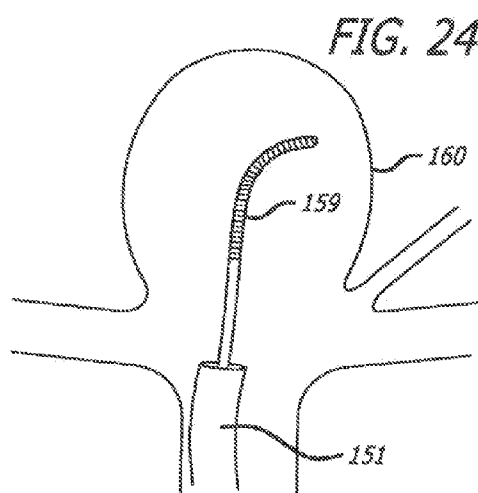
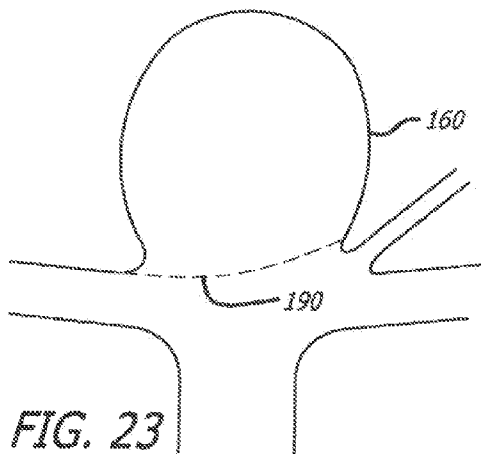

FIG. 27

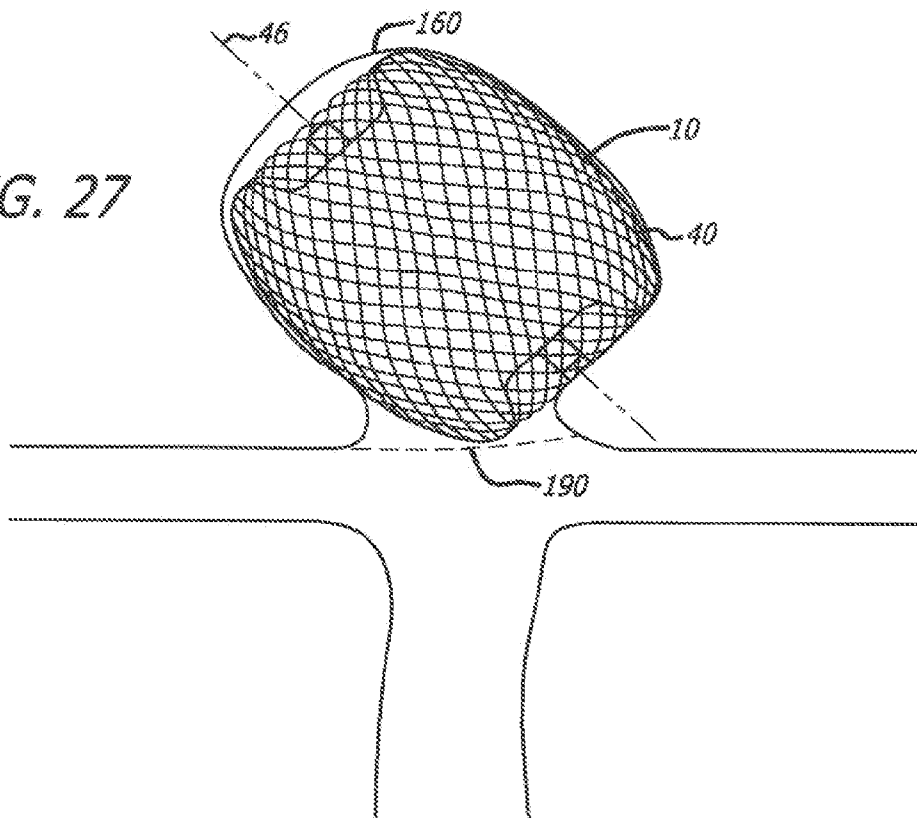
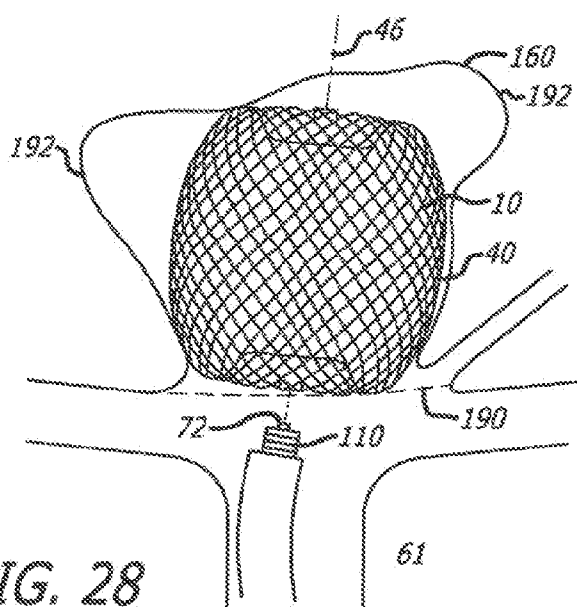

FIG. 28



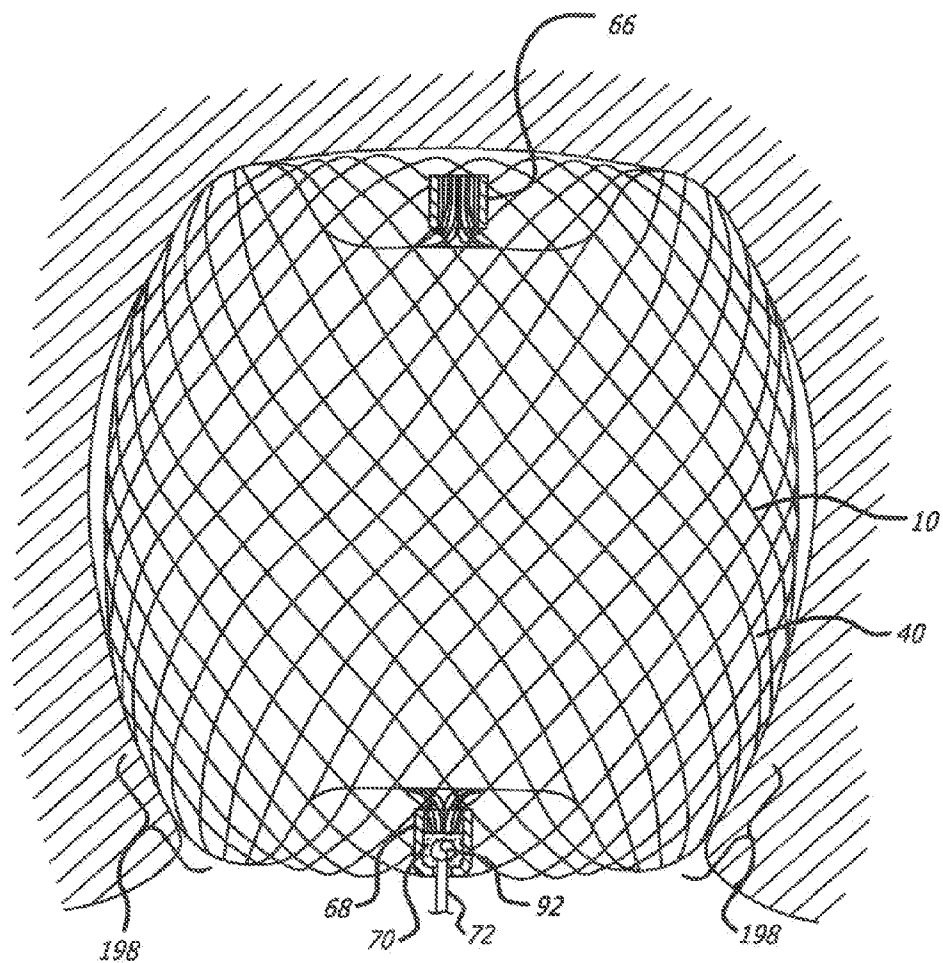

FIG. 29

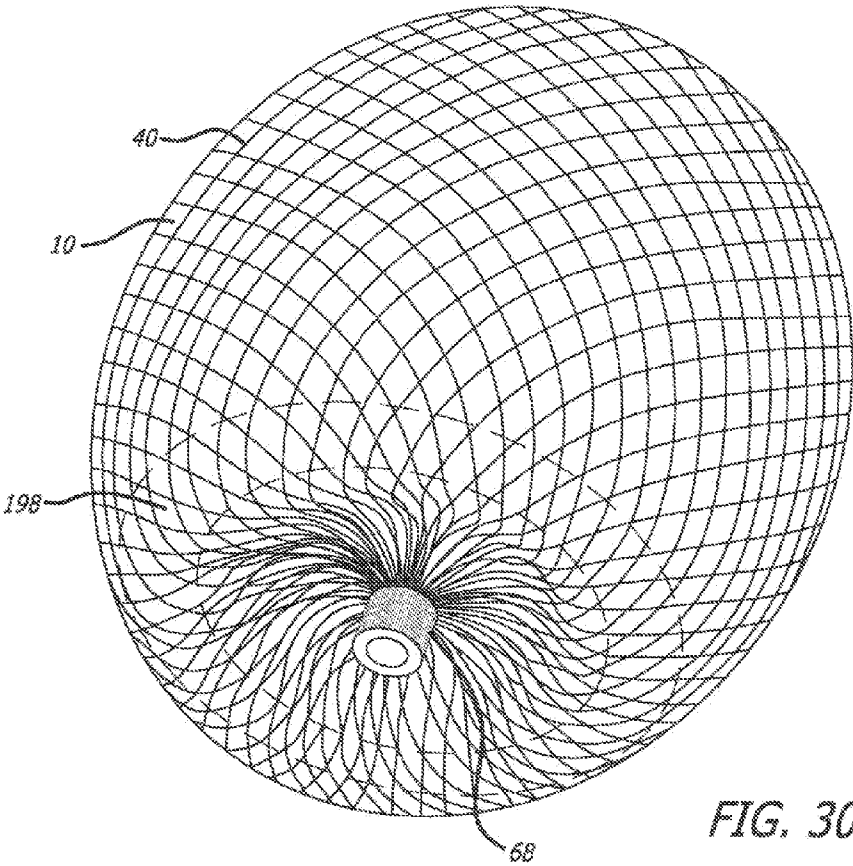

FIG. 30

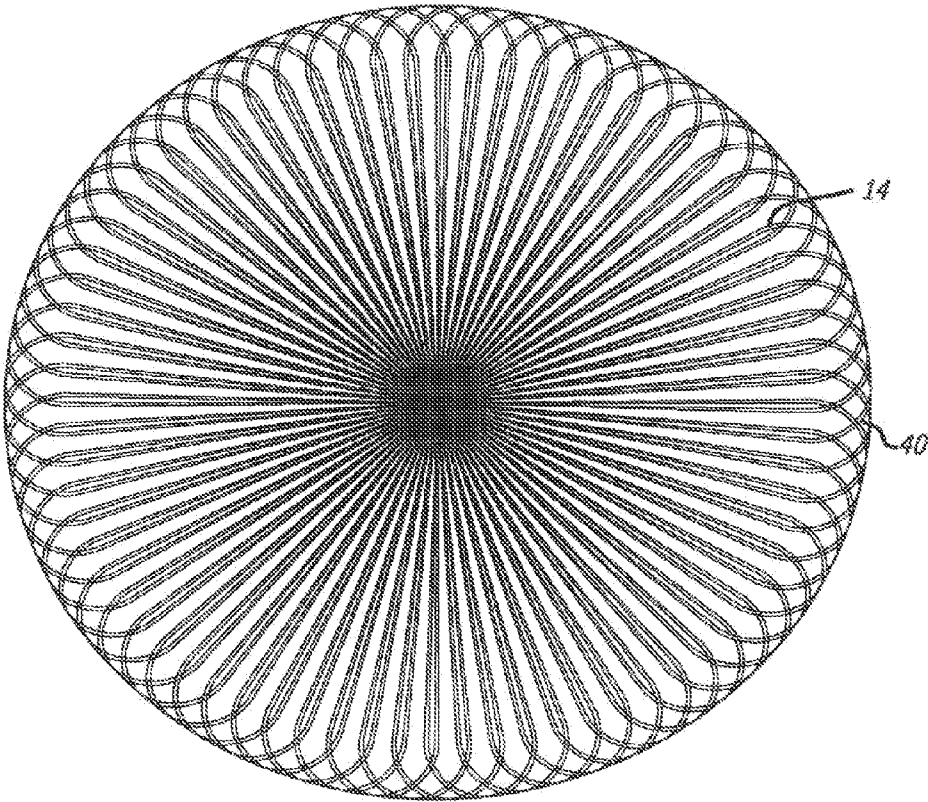

FIG. 31

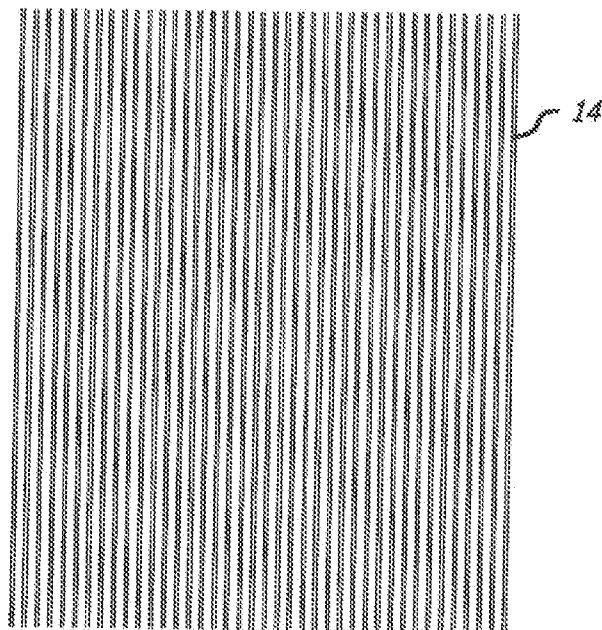

FIG. 32

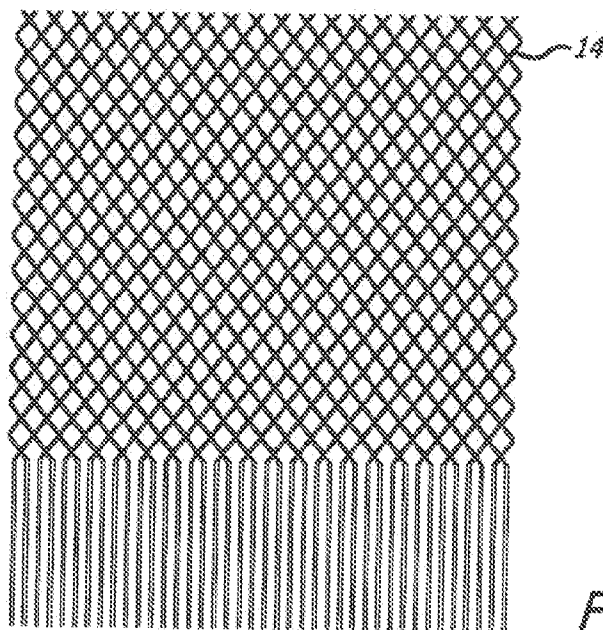

FIG. 33

FIG. 34

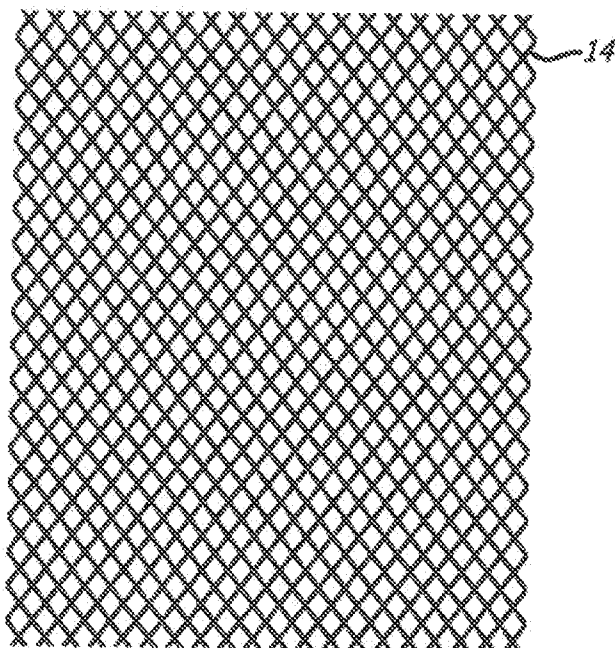
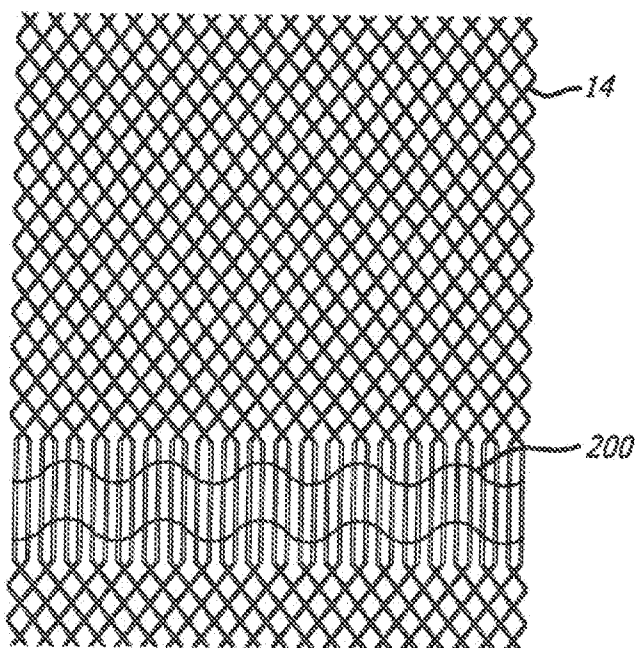

FIG. 35



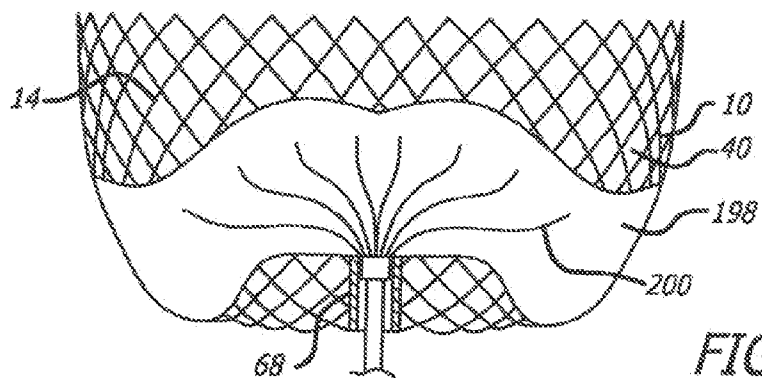

FIG. 36

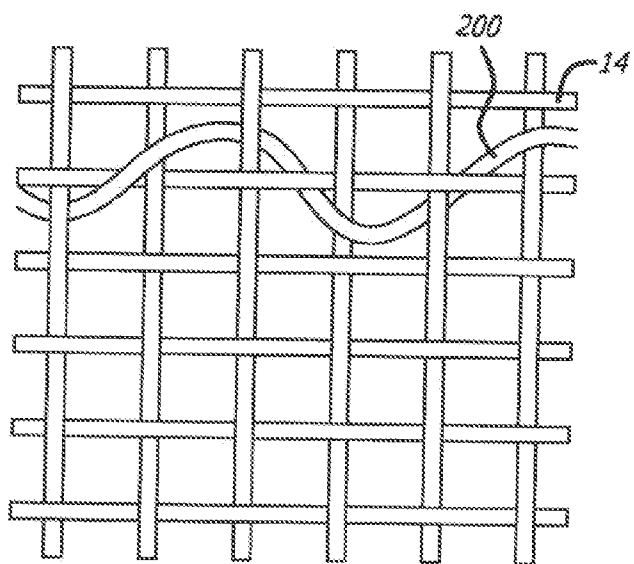

FIG. 37

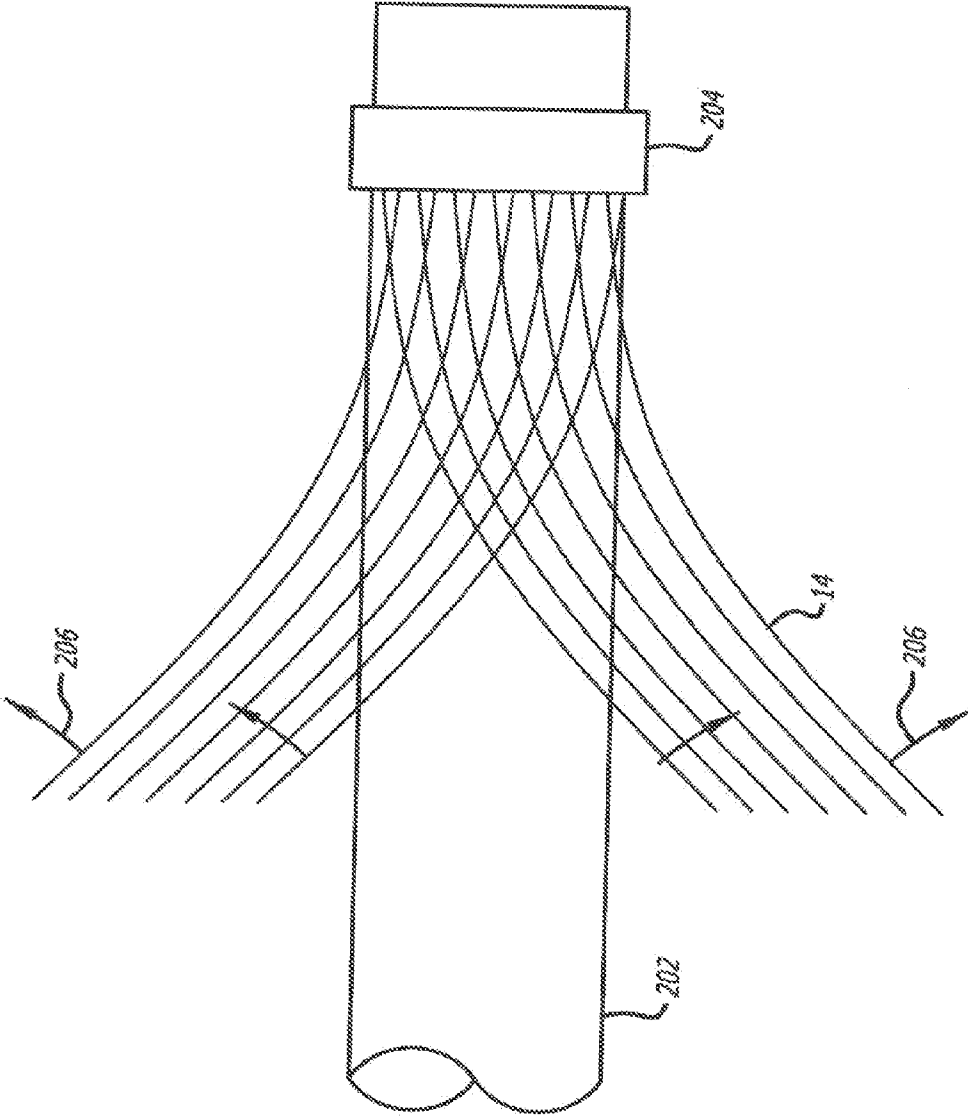

FIG. 38

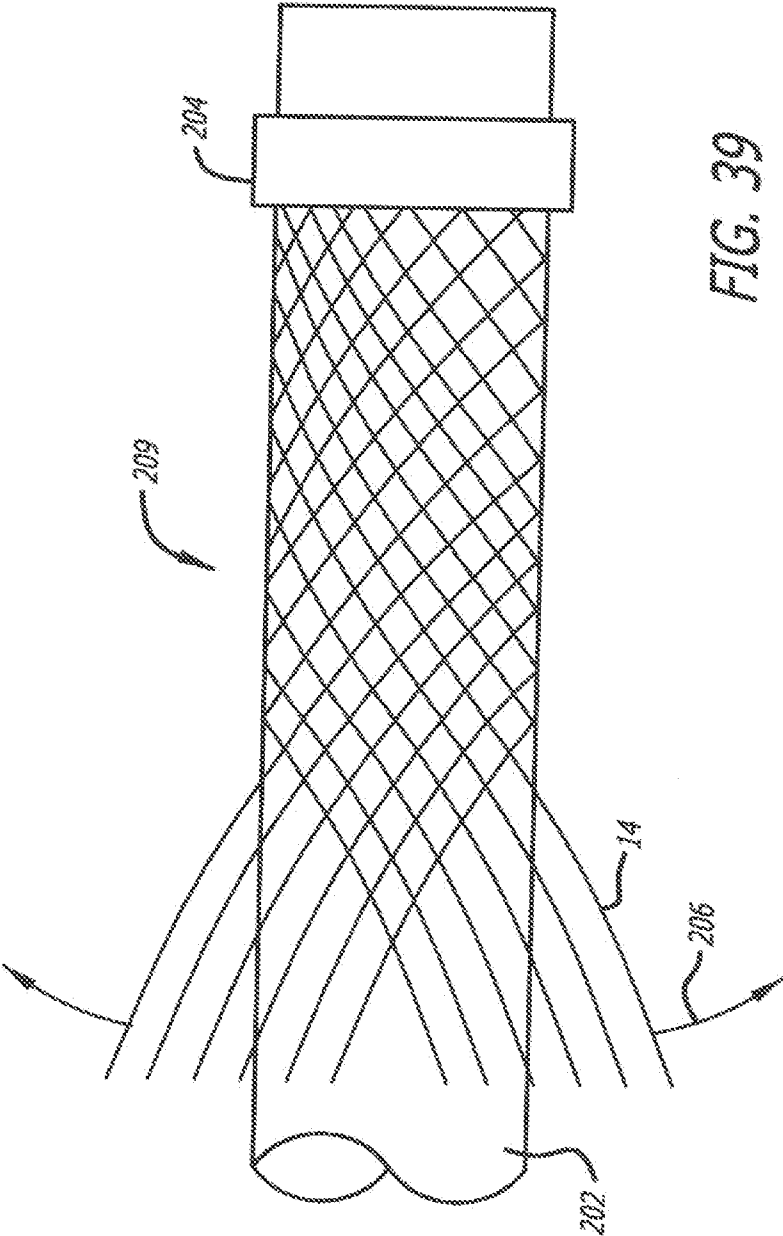
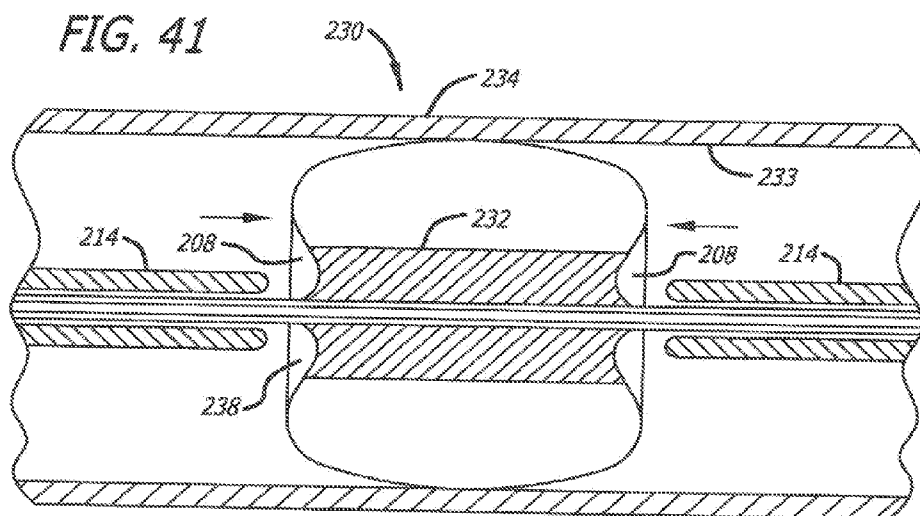
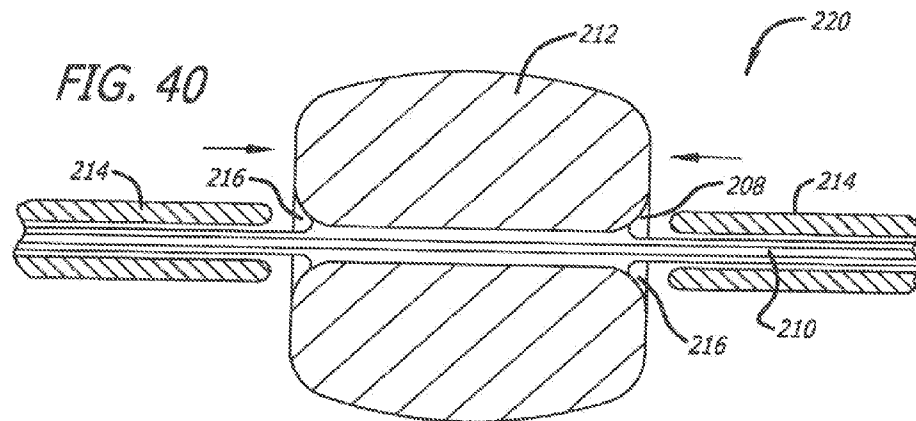

FIG. 39



FILAMENTARY DEVICES FOR TREATMENT OF VASCULAR DEFECTS

RELATED APPLICATIONS

[0001] This application claims the benefit of priority under 35 U.S.C. section 119(e) from U.S. Provisional Patent Application No. 61/050,124 filed May 2, 2008, by Cox et al. titled "Filamentary Devices for Treatment of Vascular Defects", which is incorporated by reference herein in its entirety.

[0002] This application is related to Provisional Patent Application Ser. No. 61/044,822, filed Apr. 14, 2008, entitled "Methods and Devices for Treatment of Vascular Defects", naming Brian J. Cox et al. as inventors and designated by attorney docket number SMI-0103-PV2, Provisional Patent Application Ser. No. 60/941,928, filed on Jun. 4, 2007, entitled "Method and Apparatus for Treatment of a Vascular Defect," naming Brian J. Cox et al. as inventors, and designated by attorney docket number SMI-0101.PV, U.S. Provisional Patent Application Ser. No. 60/094,683, filed on Jul. 9, 2007, entitled "Vascular Occlusion Devices," naming Brian J. Cox et al. as inventors, and designated by attorney docket number SMI-0102-PV, and U.S. Provisional Patent Application Ser. No. 60/097,366, filed on Sep. 11, 2007, entitled "Method and Apparatus for Treatment of a Vascular Defect," naming Dean Schaefer et al. as inventors, and designated by attorney docket number SMI-0103-PV, International PCT Patent Application No. PCT/US2008/065694, published Dec. 11, 2008, number WO 2008/151204, filed Jun. 3, 2008, entitled "Methods and Devices for Treatment of Vascular Defects", naming Brian J. Cox et al. as inventors and designated by attorney docket number SMI-0103-PC, which are all incorporated by reference herein in their entirety.

FIELD OF THE INVENTION

[0003] Embodiments of devices and methods herein are directed to blocking a flow of fluid through a tubular vessel or into a small interior chamber of a saccular cavity or vascular defect within a mammalian body. More specifically, embodiments herein are directed to devices and methods for treatment of a vascular defect of a patient including some embodiments directed specifically to the treatment of cerebral aneurysms of patients.

BACKGROUND

[0004] The mammalian circulatory system is comprised of a heart, which acts as a pump, and a system of blood vessels which transport the blood to various points in the body. Due to the force exerted by the flowing blood on the blood vessel the blood vessels may develop a variety of vascular defects. One common vascular defect known as an aneurysm results from the abnormal widening of the blood vessel. Typically, vascular aneurysms are formed as a result of the weakening of the wall of a blood vessel and subsequent ballooning and expansion of the vessel wall. If, for example, an aneurysm is present within an artery of the brain, and the aneurysm should burst with resulting cranial hemorrhaging, death could occur.

[0005] Surgical techniques for the treatment of cerebral aneurysms typically involve a craniotomy requiring creation of an opening in the skull of the patient through which the surgeon can insert instruments to operate directly on the patient's brain. For some surgical approaches, the brain must be retracted to expose the parent blood vessel from which the aneurysm arises. Once access to the aneurysm is gained, the

surgeon places a clip across the neck of the aneurysm thereby preventing arterial blood from entering the aneurysm. Upon correct placement of the clip the aneurysm will be obliterated in a matter of minutes. Surgical techniques may be effective treatment for many aneurysms. Unfortunately, surgical techniques for treating these types of conditions include major invasive surgical procedures which often require extended periods of time under anesthesia involving high risk to the patient. Such procedures thus require that the patient be in generally good physical condition in order to be a candidate for such procedures.

[0006] Various alternative and less invasive procedures have been used to treat cerebral aneurysms without resorting to major surgery. Some such procedures involve the delivery of embolic or filling materials into an aneurysm. The delivery of such vaso-occlusion devices or materials may be used to promote hemostasis or fill an aneurysm cavity entirely. Vaso-occlusion devices may be placed within the vasculature of the human body, typically via a catheter, either to block the flow of blood through a vessel with an aneurysm through the formation of an embolus or to form such an embolus within an aneurysm stemming from the vessel. A variety of implantable, coil-type vaso-occlusion devices are known. The coils of such devices may themselves be formed into a secondary coil shape, or any of a variety of more complex secondary shapes. Vaso-occlusive coils are commonly used to treat cerebral aneurysms but suffer from several limitations including poor packing density, compaction due to hydrodynamic pressure from blood flow, poor stability in wide-necked aneurysms and complexity and difficulty in the deployment thereof as most aneurysm treatments with this approach require the deployment of multiple coils.

[0007] Another approach to treating aneurysms without the need for invasive surgery involves the placement of sleeves or stents into the vessel and across the region where the aneurysm occurs. Such devices maintain blood flow through the vessel while reducing blood pressure applied to the interior of the aneurysm. Certain types of stents are expanded to the proper size by inflating a balloon catheter, referred to as balloon expandable stents, while other stents are designed to elastically expand in a self-expanding manner. Some stents are covered typically with a sleeve of polymeric material called a graft to form a stent-graft. Stents and stent-grafts are generally delivered to a preselected position adjacent a vascular defect through a delivery catheter. In the treatment of cerebral aneurysms, covered stents or stent-grafts have seen very limited use due to the likelihood of inadvertent occlusion of small perforator vessels that may be near the vascular defect being treated.

[0008] In addition, current uncovered stents are generally not sufficient as a stand-alone treatment. In order for stents to fit through the microcatheters used in small cerebral blood vessels, their density is usually reduced such that when expanded there is only a small amount of stent structure bridging the aneurysm neck. Thus, they do not block enough flow to cause clotting of the blood in the aneurysm and are thus generally used in combination with vaso-occlusive devices, such as the coils discussed above, to achieve aneurysm occlusion.

[0009] A number of aneurysm neck bridging devices with defect spanning portions or regions have been attempted, however, none of these devices have had a significant measure of clinical success or usage. A major limitation in their adoption and clinical usefulness is the inability to position the

defect spanning portion to assure coverage of the neck. Existing stent delivery systems that are neurovascular compatible (i.e. deliverable through a microcatheter and highly flexible) do not have the necessary rotational positioning capability. Another limitation of many aneurysm bridging devices described in the prior art is the poor flexibility. Cerebral blood vessels are tortuous and a high degree of flexibility is required for effective delivery to most aneurysm locations in the brain.

[0010] What has been needed are devices and methods for delivery and use in small and tortuous blood vessels that can substantially block the flow of blood into an aneurysm, such as a cerebral aneurysm, with a decreased risk of inadvertent aneurysm rupture or blood vessel wall damage. In addition, what has been needed are methods and devices suitable for blocking blood flow in cerebral aneurysms over an extended period of time without a significant risk of deformation, compaction or dislocation.

SUMMARY

[0011] Some embodiments of a device for treatment of a patient's vasculature include a self-expanding resilient permeable shell having a proximal end, a distal end, and a longitudinal axis. The permeable shell also includes a plurality of elongate resilient filaments with a woven structure secured relative to each other at proximal ends and distal ends thereof. The permeable shell has a radially constrained elongated state configured for delivery within a microcatheter with the thin woven filaments extending longitudinally from the proximal end to the distal end radially adjacent each other along a length of the filaments. The permeable shell also has an expanded relaxed state with a globular and longitudinally shortened configuration relative to the radially constrained state with the woven filaments forming the self-expanding resilient permeable shell in a smooth path radially expanded from the longitudinal axis between the proximal end and distal end including a plurality of openings in the shell formed between the woven filaments, the largest of said openings being configured to allow blood flow through the openings at a velocity below a thrombotic threshold velocity. The permeable shell may also include a configuration wherein at least the distal end has a reverse bend in an everted recessed configuration such that the secured distal ends of the filaments are withdrawn axially within the nominal contour of the permeable shell structure in the expanded state.

[0012] Some embodiments of a device for treatment of a patient's vasculature include a self-expanding resilient permeable shell having a proximal end, a distal end, and a longitudinal axis. The permeable shell may also include a plurality of elongate resilient filaments including large filaments and small filaments of at least two different transverse dimensions with a woven structure secured relative to each other at proximal ends and distal ends thereof. The permeable shell may also include a radially constrained elongated state configured for delivery within a microcatheter with the thin woven filaments extending longitudinally from the proximal end to the distal end radially adjacent each other along a length of the filaments. The permeable shell also has an expanded relaxed state with a globular and longitudinally shortened configuration relative to the radially constrained state with the woven filaments forming the self-expanding resilient permeable shell in a smooth path radially expanded from the longitudinal axis between the proximal end and distal end including a plurality of openings in the shell formed between the woven filaments. The permeable shell may be

configured such that at least the distal end has a reverse bend in an everted recessed configuration such that the secured distal ends of the filaments are withdrawn axially within the nominal permeable shell structure in the expanded state.

[0013] Some embodiments of a device for treatment of a patient's vasculature include a self-expanding resilient permeable shell having a proximal end, a distal end, and a longitudinal axis. The permeable shell also includes a plurality of elongate resilient filaments including large filaments and small filaments of different transverse diameters with a woven structure secured relative to each other at proximal ends and distal ends thereof. The permeable shell may also include a radially constrained elongated state configured for delivery within a microcatheter with the woven filaments extending longitudinally from the proximal end to the distal end radially adjacent each other along a length of the filaments. The permeable shell also has an expanded relaxed state with a globular and longitudinally shortened configuration relative to the radially constrained state with a major transverse diameter, the woven filaments forming the self-expanding resilient permeable shell in a smooth path radially expanded from the longitudinal axis between the proximal end and distal end, and including a plurality of openings in the shell formed between the woven filaments. The permeable shell may also be configured such that at least the distal end has a reverse bend in an everted recessed configuration such that the secured distal ends of the filaments are withdrawn axially within the nominal permeable shell structure in the expanded state. In addition, the permeable shell may have properties such that the diameter of the permeable shell in an expanded state, number and diameter of large filaments and number and diameter of small filaments are configured such that the permeable shell in an expanded state has a radial stiffness of about 0.014 pounds force (lbf) to about 0.284 lbf defined by the expression $(1.2 \times 10^6 \text{ lbf/D}^4)(N_l d_l^4 + N_s d_s^4)$ where D is a diameter of the permeable shell in the expanded state in inches, N_l is the number of large filaments in the permeable shell, N_s is the number of small filaments in the permeable shell, d_l is the diameter of the large filaments in inches, and d_s is the diameter of the small filaments in inches. The equation above contemplates two wire sizes, however, the equation is also applicable to embodiments having one wire size in which case d, will be equal to ds.

[0014] Some embodiments of a device for treatment of a patient's vasculature includes a self-expanding resilient permeable shell having a proximal end, a distal end, and a longitudinal axis. The permeable shell also has a plurality of elongate resilient filaments including large filaments and small filaments of different transverse diameters with a woven structure secured relative to each other at proximal ends and distal ends thereof. The permeable shell may also include a radially constrained elongated state configured for delivery within a microcatheter with the thin woven filaments extending longitudinally from the proximal end to the distal end radially adjacent each other along a length of the filaments. The permeable shell has an expanded relaxed state with a globular and longitudinally shortened configuration relative to the radially constrained state with a major transverse diameter, the woven filaments forming the self-expanding resilient permeable shell in a smooth path radially expanded from the longitudinal axis between the proximal end and distal end, and including a plurality of openings in the shell formed between the woven filaments. The permeable shell may also be configured such that at least the distal end

has a reverse bend in an everted recessed configuration such that the secured distal ends of the filaments are withdrawn axially within the nominal permeable shell structure in the expanded state. The permeable shell may further have properties such that the diameter of the permeable shell in an expanded state, number of all filaments and diameter of the small filaments are configured such that the maximum opening size of a portion of the permeable shell in an expanded state that spans a vascular defect opening or vascular defect neck is less than about 0.016 inches with the maximum pore or opening size defined by the expression $(1.7/N_T)(TrD - N_T/2d_w)$ where D is a diameter of the permeable shell in the expanded state in inches, N_T is the total number of filaments in the permeable shell, and d_x is the diameter of the small filaments in inches. The pore size for an opening is defined herein by the largest circular shape that may be disposed within the opening of a braided filament structure.

[0015] Some embodiments of a device for treatment of a patient's vasculature include a self-expanding resilient permeable shell having a proximal end, a distal end, and a longitudinal axis. The permeable shell further includes a plurality of elongate resilient filaments including large filaments and small filaments of different transverse diameters with a woven structure secured relative to each other at proximal ends and distal ends thereof. The permeable shell may also have a radially constrained elongated state configured for delivery within a microcatheter with the woven filaments extending longitudinally from the proximal end to the distal end radially adjacent each other along a length of the filaments. The permeable shell also includes an expanded relaxed state with a globular and longitudinally shortened configuration relative to the radially constrained state with a major transverse diameter, the woven filaments forming the self-expanding resilient permeable shell in a smooth path radially expanded from the longitudinal axis between the proximal end and distal end, and including a plurality of openings in the shell formed between the woven filaments. The permeable shell may also be configured such that at least the distal end has a reverse bend in an everted recessed configuration such that the secured distal ends of the filaments are withdrawn axially within the nominal permeable shell structure in the expanded state. The permeable shell may also have properties such that the diameter of the permeable shell in an expanded state, number and diameter of large filaments and number and diameter of small filaments are configured such that the permeable shell in a constrained state has an outer transverse diameter of less than about 0.04 inches defined by the expression $1.48((N_L d_L^2 + N_S d_S^2))^{1/2}$ where N_L is the number of large filaments in the permeable shell, N_S is the number of small filaments in the permeable shell, d_L is the diameter of the large filaments in inches, and d_S is the diameter of the small filaments in inches.

[0016] Some embodiments of a method of treating a vascular defect of a patient include providing a device for treatment of a patient's vasculature comprising a self-expanding resilient permeable shell of woven filaments, the permeable shell having a proximal end, a distal end, a longitudinal axis, a radially constrained elongated state configured for delivery within a microcatheter with the woven filaments extending longitudinally from the proximal end to the distal radially adjacent each other. The permeable shell may also have an expanded relaxed state with a globular and axially shortened configuration relative to the constrained state with the woven filaments forming the self-expanding resilient permeable

shell in a smooth path radially expanded from the longitudinal axis between the proximal end and distal end with the shell having a reverse bend at each end in an everted recessed configuration such that a hub at the distal end is withdrawn axially within the permeable shell structure. The permeable shell also has and a plurality of openings in the shell formed between the woven filaments. Once provided, a delivery system is advanced within a patient's body such that a distal end of the delivery system is disposed at a position adjacent or within a vascular defect to be treated. The device is then axially advanced within the delivery system while in a radially constrained state with an elongate delivery apparatus which has a distal end releasably secured to a proximal end of the device. The device is further advanced distally until the device emerges from a distal end of the delivery system. The device is further advanced from the distal end of the delivery system until it is deployed such that the woven filaments of the device radially expand from their radially constrained state, and expand into a globular configuration of the permeable shell. The deployed device then covers and acutely occludes at least a portion of an opening or neck of the vascular defect due to the pore size of the permeable shell which slows a flow of blood therethrough to a velocity below a thrombotic threshold velocity.

[0017] Some methods of occluding a vascular defect of a patient's vasculature include providing an expandable, porous vascular occlusion device formed from a woven shell of a plurality of filamentary members that are connected to each other on at least the proximal ends of the members forming a substantially closed globular structure with a shape that approximates or is slightly larger than a size and shape of the vascular defect and wherein the distal ends of the filamentary members are recessed within a nominal surface contour of the globular structure of the device. Once the device is provided, the device may be collapsed for delivery into the vascular system of the patient. The collapsed device may then be inserted through an incision in the patient's body and the device released and expanded at the vascular defect such that an outer surface contour of the device substantially fills the vascular defect. The device then substantially occludes the vascular defect acutely and becomes substantially covered with clotted blood.

[0018] Some embodiments of a delivery system for deployment of a device for treatment of a patient's vasculature include a microcatheter having an inner lumen extending a length thereof and a device for treatment of a patient's vasculature disposed within the inner lumen of the microcatheter. The device also includes a self-expanding resilient permeable shell of thin coupled filaments, the permeable shell having a proximal end, a distal end, a longitudinal axis, a radially constrained elongated state configured for delivery within a microcatheter with the thin woven filaments extending longitudinally from the proximal end to the distal radially adjacent each other. The permeable shell also has an expanded relaxed state with a globular and axially shortened configuration relative to the constrained state with the woven filaments forming the self-expanding resilient permeable shell in a smooth path radially expanded from the longitudinal axis between the proximal end and distal end. The permeable shell may further include a reverse bend at each end in an everted recessed configuration such that a hub at the distal end is disposed axially within the permeable shell structure. The permeable shell also has a plurality of openings formed between the woven filaments, the permeable shell further

having a portion when in the expanded relaxed state that is configured to span an opening of a patient's vascular defect. The delivery system further includes an elongate delivery apparatus having a proximal end and a distal end releasably secured to a proximal hub of the device.

[0019] Some embodiments of a method of manufacturing a device for treatment of a patient's vasculature include braiding a plurality of elongate resilient filaments over a cylindrically shaped mandrel forming a braided tubular member. The elongate filaments of the braided tubular member may then be heat set in an expanded relaxed state with a globular and axially shortened configuration relative to a constrained state with the woven filaments forming the self-expanding resilient permeable shell in a smooth path radially expanded from a longitudinal axis of the device between a proximal end and a distal end of the device with the shell having a reverse bend at the distal end in an everted recessed configuration such that a hub at the distal end is withdrawn disposed within the permeable shell structure and a plurality of openings in the shell are formed between the woven filaments. The proximal ends of the filaments are then secured together and the distal ends of the filaments are secured together.

[0020] Some embodiments of a device for treatment of a patient's vasculature include a self-expanding resilient permeable shell of thin interconnected filaments that serves as a support structure and integral defect spanning structure, the permeable shell having a first end, a second end, a longitudinal axis, a constrained cylindrical state configured for delivery within a microcatheter with the thin interconnected filaments extending from the first end to the second end. The permeable shell also has an expanded relaxed state with a globular and axially shortened configuration relative to the constrained state with filaments forming a smooth arc between the first end and second end with a reverse bend at each end in an everted recessed configuration. The permeable shell further has a defect spanning portion when in the expanded relaxed state that is configured to span an opening of a patient's vascular defect.

[0021] Some embodiments of a method of treating a vascular defect include providing a device for treatment of a patient's vasculature having a self-expanding resilient permeable shell of thin interconnected filaments that serves as a support structure and integral defect spanning structure. The permeable shell also has a first end, a second end, a longitudinal axis, a constrained cylindrical state configured for delivery within a microcatheter with the thin interconnected filaments extending from the first end to the second end. The permeable shell also has an expanded relaxed state with a globular and axially shortened configuration relative to the constrained state with filaments forming a smooth arc between the first end and second end with a reverse bend at each end in an everted recessed configuration. The permeable shell further has a defect spanning portion when in the expanded relaxed state that is configured to span an opening of a patient's vascular defect. Once provided, the delivery system may be advanced to a position adjacent a vascular defect to be treated and positioned with a distal end disposed inside the vascular defect. The device may then be deployed such that the permeable shell self-expands and the defect spanning portion of the permeable shell covers at least a portion of the defect opening or neck.

[0022] Some embodiments of a device for treatment of a patient's vasculature include a self-expanding resilient permeable shell of thin interconnected filaments that serves as a

support structure and integral defect spanning structure. The permeable shell also has a first end, a second end, a longitudinal axis, a constrained cylindrical state configured for delivery within a microcatheter with the thin interconnected filaments extending from the first end to the second end. The permeable shell also has an expanded relaxed state with a globular and axially shortened configuration relative to the constrained state with filaments forming a smooth arc between the first end and second end with a reverse bend at each end in an everted recessed configuration. The permeable shell further includes a defect spanning portion when in the expanded relaxed state that is configured to span an opening of a patient's vascular defect. Some embodiments of a method of treating a vascular defect include providing a device for treatment of a patient's vasculature having a self-expanding resilient permeable shell of thin interconnected filaments that serves as a support structure and integral defect spanning structure. The permeable shell also has a first end, a second end, a longitudinal axis, a constrained cylindrical state configured for delivery within a microcatheter with the thin interconnected filaments extending from the first end to the second end. The permeable shell further includes an expanded relaxed state with a globular and axially shortened configuration relative to the constrained state with filaments forming a smooth arc between the first end and second end with a reverse bend at each end in an everted recessed configuration. The permeable shell also has a defect spanning portion when in the expanded relaxed state that is configured to span an opening of a patient's vascular defect. Once the device has been provided, a delivery system may be advanced to a position adjacent a vascular defect to be treated. The device is then positioned inside the vascular defect and deployed such that the permeable shell self-expands and the defect spanning portion of the permeable shell covers at least a portion of the defect opening or neck.

BRIEF DESCRIPTION OF THE DRAWINGS

[0023] FIG. 1 is an elevation view of an embodiment of a device for treatment of a patient's vasculature and a plurality of arrows indicating inward radial force.

[0024] FIG. 2 is an elevation view of a beam supported by two simple supports and a plurality of arrows indicating force against the beam.

[0025] FIG. 3 is a bottom perspective view of an embodiment of a device for treatment of a patient's vasculature.

[0026] FIG. 4 is an elevation view of the device for treatment of a patient's vasculature of FIG. 3.

[0027] FIG. 5 is a transverse cross sectional view of the device of FIG. 4 taken along lines 5-5 in FIG. 4.

[0028] FIG. 6 shows the device of FIG. 4 in longitudinal section taken along lines 6-6 in FIG. 4.

[0029] FIG. 7 is an enlarged view of the woven filament structure taken from the encircled portion 7 shown in FIG. 5.

[0030] FIG. 8 is an enlarged view of the woven filament structure taken from the encircled portion 8 shown in FIG. 6.

[0031] FIG. 9 is a proximal end view of the device of FIG. 3.

[0032] FIG. 10 is a transverse sectional view of a proximal hub portion of the device in FIG. 6 indicated by lines 10-10 in FIG. 6.

[0033] FIG. 11 is an elevation view in partial section of a distal end of a delivery catheter with the device for treatment of a patient's vasculature of FIG. 3 disposed therein in a collapsed constrained state.

[0034] FIG. 12 is an elevation view of a distal portion of a delivery device or actuator showing some internal structure of the device.

[0035] FIG. 13 is an elevation view of the delivery device of FIG. 12 with the addition of some tubular elements over the internal structures.

[0036] FIG. 14 is an elevation view of the distal portion of the delivery device of FIG. 13 with an outer coil and marker in place.

[0037] FIG. 15 is an elevation view of a proximal portion of the delivery device.

[0038] FIG. 16 illustrates an embodiment of a filament configuration for a device for treatment of a patient's vasculature.

[0039] FIG. 17 is a schematic view of a patient being accessed by an introducer sheath, a microcatheter and a device for treatment of a patient's vasculature releasably secured to a distal end of a delivery device or actuator.

[0040] FIG. 18 is a sectional view of a terminal aneurysm,

[0041] FIG. 19 is a sectional view of an aneurysm.

[0042] FIG. 20 is a schematic view in section of an aneurysm showing perpendicular arrows which indicate interior nominal longitudinal and transverse dimensions of the aneurysm.

[0043] FIG. 21 is a schematic view in section of the aneurysm of FIG. 20 with a dashed outline of a device for treatment of a patient's vasculature in a relaxed unconstrained state that extends transversely outside of the walls of the aneurysm.

[0044] FIG. 22 is a schematic view in section of an outline of a device represented by the dashed line in FIG. 21 in a deployed and partially constrained state within the aneurysm.

[0045] FIGS. 23-26 show a deployment sequence of a device for treatment of a patient's vasculature.

[0046] FIG. 27 is an elevation view in partial section of an embodiment of a device for treatment of a patient's vasculature deployed within an aneurysm at a tilted angle.

[0047] FIG. 28 is an elevation view in partial section of an embodiment of a device for treatment of a patient's vasculature deployed within an irregularly shaped aneurysm.

[0048] FIG. 29 shows an elevation view in section of a device for treatment of a patient's vasculature deployed within a vascular defect aneurysm.

[0049] FIG. 30 shows a proximal perspective view of an embodiment of a device for treatment of a patient's vasculature with a sealing zone embodiment indicated by a set of dashed lines.

[0050] FIGS. 31-35 illustrate various different embodiments of braiding patterns that may be used for permeable shells of devices for treatment of a patient's vasculature.

[0051] FIG. 36 illustrates a device for treatment of a patient's vasculature that includes non-structural fibers in the permeable shell structure of the device.

[0052] FIG. 37 is an enlarged view of non-structural fibers woven into filaments of a permeable shell structure.

[0053] FIG. 38 is an elevation view of a mandrel used for manufacture of a braided tubular member for construction of an embodiment of a device for treatment of a patient's vasculature with the initiation of the braiding process shown.

[0054] FIG. 39 is an elevation view of a braiding process for a braided tubular member used for manufacture of a device.

[0055] FIG. 40 is an elevation view in partial section of an embodiment of a fixture for heat setting a braided tubular member for manufacture of a device for treatment of a patient's vasculature.

[0056] FIG. 41 is an elevation view in partial section of an embodiment of a fixture for heat setting a braided tubular member for manufacture of a device for treatment of a patient's vasculature.

DETAILED DESCRIPTION

[0057] Discussed herein are devices and methods for the treatment of vascular defects that are suitable for minimally invasive deployment within a patient's vasculature, and particularly, within the cerebral vasculature of a patient. For such embodiments to be safely and effectively delivered desired treatment site and effectively deployed, some device embodiments may be configured for collapse to a low profile constrained state with a transverse dimension suitable for delivery through an inner lumen of a microcatheter and deployment from a distal end thereof. Embodiments of these devices may also maintain a clinically effective configuration with sufficient mechanical integrity once deployed so as to withstand dynamic forces within a patient's vasculature over time that may otherwise result in compaction of a deployed device. It may also be desirable for some device embodiments to acutely occlude a vascular defect of a patient during the course of a procedure in order to provide more immediate feedback regarding success of the treatment to a treating physician.

[0058] Some embodiments are particularly useful for the treatment of cerebral aneurysms by reconstructing a vascular wall so as to wholly or partially isolate a vascular defect from a patient's blood flow. Some embodiments may be configured to be deployed within a vascular defect to facilitate reconstruction, bridging of a vessel wall or both in order to treat the vascular defect. For some of these embodiments, the permeable shell of the device may be configured to anchor or fix the permeable shell in a clinically beneficial position. For some embodiments, the device may be disposed in whole or in part within the vascular defect in order to anchor or fix the device with respect to the vascular structure or defect. The permeable shell may be configured to span an opening, neck or other portion of a vascular defect in order to isolate the vascular defect, or a portion thereof, from the patient's nominal vascular system in order allow the defect to heal or to otherwise minimize the risk of the defect to the patient's health.

[0059] For some or all of the embodiments of devices for treatment of a patient's vasculature discussed herein, the permeable shell may be configured to allow some initial perfusion of blood through the permeable shell. The porosity of the permeable shell may be configured to sufficiently isolate the vascular defect so as to promote healing and isolation of the defect, but allow sufficient initial flow through the permeable shell so as to reduce or otherwise minimize the mechanical force exerted on the membrane the dynamic flow of blood or other fluids within the vasculature against the device. For some embodiments of devices for treatment of a patient's vasculature, only a portion of the permeable shell that spans the opening or neck of the vascular defect, sometimes referred to as a defect spanning portion, need be permeable and/or conducive to thrombus formation in a patient's bloodstream. For such embodiments, that portion of the device that does not span an opening or neck of the vascular defect may be substantially non-permeable or completely permeable

with a pore or opening configuration that is too large to effectively promote thrombus formation.

[0060] In general, it may be desirable in some cases to use a hollow, thin walled device with a permeable shell of resilient material that may be constrained to a low profile for delivery within a patient. Such a device may also be configured to expand radially outward upon removal of the constraint such that the shell of the device assumes a larger volume and fills or otherwise occludes a vascular defect within which it is deployed. The outward radial expansion of the shell may serve to engage some or all of an inner surface of the vascular defect whereby mechanical friction between an outer surface of the permeable shell of the device and the inside surface of the vascular defect effectively anchors the device within the vascular defect. Some embodiments of such a device may also be partially or wholly mechanically captured within a cavity of a vascular defect, particularly where the defect has a narrow neck portion with a larger interior volume. In order to achieve a low profile and volume for delivery and be capable of a high ratio of expansion by volume, some device embodiments include a matrix of woven or braided filaments that are coupled together by the interwoven structure so as to form a self-expanding permeable shell having a pore or opening pattern between couplings or intersections of the filaments that is substantially regularly spaced and stable, while still allowing for conformity and volumetric constraint.

[0061] As used herein, the terms woven and braided are used interchangeably to mean any form of interlacing of filaments to form a mesh structure. In the textile and other industries, these terms may have different or more specific meanings depending on the product or application such as whether an article is made in a sheet or cylindrical form. For purposes of the present disclosure, these terms are used interchangeably.

[0062] For some embodiments, three factors may be critical for a woven or braided wire occlusion device for treatment of a patient's vasculature that can achieve a desired clinical outcome in the endovascular treatment of cerebral aneurysms. We have found that for effective use in some applications, it may be desirable for the implant device to have sufficient radial stiffness for stability, limited pore size for near-complete acute (intra-procedural) occlusion and a collapsed profile which is small enough to allow insertion through an inner lumen of a microcatheter. A device with a radial stiffness below a certain threshold may be unstable and may be at higher risk of embolization in some cases. Larger pores between filament intersections in a braided or woven structure may not generate thrombus and occlude a vascular defect in an acute setting and thus may not give a treating physician or health professional such clinical feedback that the flow disruption will lead to a complete and lasting occlusion of the vascular defect being treated. Delivery of a device for treatment of a patient's vasculature through a standard microcatheter may be highly desirable to allow access through the tortuous cerebral vasculature in the manner that a treating physician is accustomed.

[0063] For some embodiments, it may be desirable to use filaments having two or more different diameters or transverse dimensions to form a permeable shell in order to produce a desired configuration as discussed in more detail below. The radial stiffness of a two-filament (two different diameters) woven device may be expressed as a function of the number of filaments and their diameters, as follows:

$$s_{radial}=(1.2 \times 10^6 \text{ lbf/D}^4)(N_l d_l^4 + N_s d_s^4)$$

[0064] where S_{radial} is the radial stiffness in pounds force (lbf),

[0065] D is the Device diameter (transverse dimension),

[0066] N_l is the number of large filaments,

[0067] N_s is the number of small filaments,

[0068] d_l is the diameter of the large filaments in inches, and

[0069] d_s is the diameter of the small filaments in inches.

[0070] Using this expression, the radial stiffness, S_{radial} may be between about 0.014 and 0.284 lbf force for some embodiments of particular clinical value.

[0071] The maximum pore size in a portion of a device that spans a neck or opening of a vascular defect desirable for some useful embodiments of a woven wire device for treatment of a patient's vasculature may be expressed as a function of the total number of all filaments, filament diameter and the device diameter. The difference between filament sizes where two or more filament diameters or transverse dimensions are used, may be ignored in some cases for devices where the filament size(s) are very small compared to the device dimensions. For a two-filament device, the smallest filament diameter may be used for the calculation. Thus, the maximum pore size for such embodiments may be expressed as follows:

$$P_{max}=(1.7/N_T)(mD-(N_T d_w/2))$$

[0072] where P. is the average pore size,

[0073] D is the Device diameter (transverse dimension),

[0074] N_T is the total number of all filaments, and

[0075] d_w is the diameter of the filaments (smallest) in inches.

[0076] Using this expression, the maximum pore size, P_{max} , of a portion of a device that spans an opening of a vascular defect or neck, or any other suitable portion of a device, may be less than about 0.016 inches or about 400 microns for some embodiments. In some embodiments the maximum pore size for a defect spanning portion or any other suitable portion of a device may be less than about 0.012 inches or about 300 microns.

[0077] The collapsed profile of a two-filament (profile having two different filament diameters) woven filament device may be expressed as the function:

$$P_c=1.48((N_l d_l + N_s d_s^2))^{1/2}$$

[0078] where P_c is the collapsed profile of the device,

[0079] N_l is the number of large filaments,

[0080] N_s is the number of small filaments,

[0081] d_l is the diameter of the large filaments in inches, and

[0082] d_s is the diameter of the small filaments in inches.

[0083] Using this expression, the collapsed profile P_c may be less than about 1.0 mm for some embodiments of particular clinical value. In some embodiments of particular clinical value, the device may be constructed so as to have all three factors (S_{radial} , P_{max} and P_c) above within the ranges discussed above; s_{radial} between about 0.014 lbf and 0.284 lbf, P_c less than about 300 microns and P_c less than about 1.0 mm, simultaneously. In some such embodiments, the device may be made to include about 70 filaments to about 300 filaments. In some cases, the filaments may have an outer transverse dimension or diameter of about 0.0004 inches to about 0.002 inches. As has been discussed, some embodiments of devices

for treatment of a patient's vasculature call for sizing the device which approximates (or with some over-sizing) the vascular site dimensions to fill the vascular site. One might assume that scaling of a device to larger dimensions and using larger filaments would suffice for such larger embodiments of a device. However, for the treatment of brain aneurysms, the diameter or profile of the radially collapsed device is limited by the catheter sizes that can be effectively navigated within the small, tortuous vessels of the brain. Further, as a device is made larger with a given or fixed number of resilient filaments having a given size or thickness, the pores or openings between junctions of the filaments are correspondingly larger. In addition, for a given filament size the flexural modulus or stiffness of the filaments and thus the structure decrease with increasing device dimension. Flexural modulus may be defined as the ratio of stress to strain. Thus, a device may be considered to have a high flexural modulus or be stiff if the strain (deflection) is low under a given force. A stiff device may also said to have low compliance.

[0084] To properly configure larger size devices for treatment of a patient's vasculature, it may be useful to model the force on a device when the device is deployed into a vascular site or defect, such as a blood vessel or aneurysm, that has a diameter or transverse dimension that is smaller than a nominal diameter or transverse dimension of the device in a relaxed unconstrained state. As discussed, it may be advisable to "over-size" the device in some cases so that there is a residual force between an outside surface of the device and an inside surface of the vascular wall. The inward radial force on a device **10** that results from over-sizing is illustrated schematically in FIG. **1** with the arrows **12** in the figure representing the inward radial force. As shown in FIG. **2**, these compressive forces on the filaments **14** of the device in FIG. **1** can be modeled as a simply supported beam **16** with a distributed load or force as show by the arrows **18** in the figure. It can be seen from the equation below for the deflection of a beam with two simple supports **20** and a distributed load that the deflection is a function of the length, L to the 4th power:

$$\text{Deflection of Beam} = 5FL^4 / 384EI$$

- [0085]** where F=force,
- [0086]** L=length of beam,
- [0087]** E=Young's Modulus, and
- [0088]** I=moment of inertia.

[0089] Thus, as the size of the device increases and L increases, the compliance increases substantially. Accordingly, an outward radial force exerted by an outside surface of the filaments **14** of the device **10** against a constraining force when inserted into a vascular site such as blood vessel or aneurysm is lower for a given amount of device compression or over-sizing. This force may be important in some applications to assure device stability and to reduce the risk of migration of the device and potential distal embolization.

[0090] In some embodiments, a combination of small and large filament sizes may be utilized to make a device with a desired radial compliance and yet have a collapsed profile which is configured to fit through an inner lumen of commonly used. A device fabricated with even a small number of relatively large filaments **14** can provide reduced radial compliance (or increased stiffness) compared to a device made with all small filaments. Even a relatively small number of larger filaments may provide a substantial increase in bending stiffness due to change in the moment of Inertia that results from an increase in diameter without increasing the total

cross sectional area of the filaments. The moment of inertia (I) of a round wire or filament may be defined by the equation:

$$I = \pi d^4 / 64$$

[0091] where d is the diameter of the wire or filament.

Since the moment of inertia is a function of filament diameter to the fourth power, a small change in the diameter greatly increases the moment of inertia. Thus, a small changes in filament size can have substantial impact on the deflection at a given load and thus the compliance of the device,

[0092] Thus, the stiffness can be increased by a significant amount without a large increase in the cross sectional area of a collapsed profile of the device **10**. This may be particularly important as device embodiments are made larger to treat large aneurysms. While large cerebral aneurysms may be relatively rare, they present an important therapeutic challenge as some embolic devices currently available to physicians have relatively poor results compared to smaller aneurysms. As such, some embodiments of devices for treatment of a patient's vasculature may be formed using a combination of filaments **14** with a number of different diameters such as 2, 3, 4, 5 or more different diameters or transverse dimensions. In device embodiments where filaments with two different diameters are used, some larger filament embodiments may have a transverse dimension of about 0.001 inches to about 0.004 inches and some small filament embodiments may have a transverse dimension or diameter of about 0.0004 inches and about 0.0015 inches, more specifically, about 0.0004 inches to about 0.001 inches. The ratio of the number of large filaments to the number of small filaments may be between about 2 and 12 and may also be between about 4 and 8. In some embodiments, the difference in diameter or transverse dimension between the larger and smaller filaments may be less than about 0.004 inches, more specifically, less than about 0.0035 inches, and even more specifically, less than about 0.002 inches.

[0093] As discussed above, device embodiments **10** for treatment of a patient's vasculature may include a plurality of wires, fibers, threads, tubes or other filamentary elements that form a structure that serves as a permeable shell. For some embodiments, a globular shape may be formed from such filaments by connecting or securing the ends of a tubular braided structure. For such embodiments, the density of a braided or woven structure may inherently increase at or near the ends where the wires or filaments **14** are brought together and decrease at or near a middle portion **30** disposed between a proximal end **32** and distal end **34** of the permeable shell **40**. For some embodiments, an end or any other suitable portion of a permeable shell **40** may be positioned in an opening or neck of a vascular defect such as an aneurysm for treatment. As such, a braided or woven filamentary device with a permeable shell may not require the addition of a separate defect spanning structure having properties different from that of a nominal portion of the permeable shell to achieve hemostasis and occlusion of the vascular defect. Such a filamentary device may be fabricated by braiding, weaving or other suitable filament fabrication techniques. Such device embodiments may be shape set into a variety of three dimensional shapes such as discussed herein.

[0094] Referring to FIGS. **3-10**, an embodiment of a device for treatment of a patient's vasculature **10** is shown. The device **10** includes a self-expanding resilient permeable shell **40** having a proximal end **32**, a distal end **34**, a longitudinal axis **46** and further comprising a plurality of elongate resilient

filaments **14** including large filaments **48** and small filaments **50** of at least two different transverse dimensions as shown in more detail in FIGS. **5**, **7** and **18**. The filaments **14** have a woven structure and are secured relative to each other at proximal ends **60** and distal ends **62** thereof. The permeable shell **40** of the device has a radially constrained elongated state configured for delivery within a microcatheter **61**, as shown in FIG. **11**, with the thin woven filaments **14** extending longitudinally from the proximal end **42** to the distal end **44** radially adjacent each other along a length of the filaments.

[0095] As shown in FIGS. **3-6**, the permeable shell **40** also has an expanded relaxed state with a globular and longitudinally shortened configuration relative to the radially constrained state. In the expanded state, the woven filaments **14** form the self-expanding resilient permeable shell **40** in a smooth path radially expanded from a longitudinal axis **46** of the device between the proximal end **32** and distal end **34**. The woven structure of the filaments **14** includes a plurality of openings **64** in the permeable shell **40** formed between the woven filaments. For some embodiments, the largest of said openings **64** may be configured to allow blood flow through the openings only at a velocity below a thrombotic threshold velocity. Thrombotic threshold velocity has been defined, at least by some, as the time-average velocity at which more than 50% of a vascular graft surface is covered by thrombus when deployed within a patient's vasculature. In the context of aneurysm occlusion, a slightly different threshold may be appropriate. Accordingly, the thrombotic threshold velocity as used herein shall include the velocity at which clotting occurs within or on a device, such as device **10**, deployed within a patient's vasculature such that blood flow into a vascular defect treated by the device is substantially blocked in less than about 1 hour or otherwise during the treatment procedure. The blockage of blood flow into the vascular defect may be indicated in some cases by minimal contrast agent entering the vascular defect after a sufficient amount of contrast agent has been injected into the patient's vasculature upstream of the implant site and visualized as it dissipates from that site. Such sustained blockage of flow within less than about 1 hour or during the duration of the implantation procedure may also be referred to as acute occlusion of the vascular defect.

[0096] As such, once the device **10** is deployed, any blood flowing through the permeable shell may be slowed to a velocity below the thrombotic threshold velocity and thrombus will begin to form on and around the openings in the permeable shell **40**. Ultimately, this process may be configured to produce acute occlusion of the vascular defect within which the device **10** is deployed. For some embodiments, at least the distal end of the permeable shell **40** may have a reverse bend in an everted configuration such that the secured distal ends **62** of the filaments **14** are withdrawn axially within the nominal permeable shell structure or contour in the expanded state. For some embodiments, the proximal end of the permeable shell further includes a reverse bend in an everted configuration such that the secured proximal ends **60** of the filaments **14** are withdrawn axially within the nominal permeable shell structure **40** in the expanded state. As used herein, the term everted may include a structure that is everted, partially everted and/or recessed with a reverse bend as shown in the device embodiment of FIGS. **3-6**. For such embodiments, the ends **60** and **62** of the filaments **14** of the permeable shell or hub structure disposed around the ends

may be withdrawn within or below the globular shaped periphery of the permeable shell of the device.

[0097] The elongate resilient filaments **14** of the permeable shell **40** may be secured relative to each other at proximal ends **60** and distal ends **62** thereof by one or more methods including welding, soldering, adhesive bonding, epoxy bonding or the like. In addition to the ends of the filaments being secured together, a distal hub **66** may also be secured to the distal ends **62** of the thin filaments **14** of the permeable shell **40** and a proximal hub **68** secured to the proximal ends **60** of the thin filaments **14** of the permeable shell **40**. The proximal hub **68** may include a cylindrical member that extends proximally beyond the proximal ends **60** of the thin filaments so as to form a cavity **70** within a proximal portion of the proximal hub **68**. The proximal cavity **70** may be used for holding adhesives such as epoxy, solder or any other suitable bonding agent for securing an elongate detachment tether **72** that may in turn be detachably secured to a delivery apparatus such as is shown in FIGS. **11-15**.

[0098] For some embodiments, the elongate resilient filaments **14** of the permeable shell **40** may have a transverse cross section that is substantially round in shape and be made from a superelastic material that may also be a shape memory metal. The shape memory metal of the filaments of the permeable shell **40** may be heat set in the globular configuration of the relaxed expanded state as shown in FIGS. **3-6**. Suitable superelastic shape memory metals may include alloys such as NiTi alloy and the like. The superelastic properties of such alloys may be useful in providing the resilient properties to the elongate filaments **14** so that they can be heat set in the globular form shown, fully constrained for delivery within an inner lumen of a microcatheter and then released to self expand back to substantially the original heat set shape of the globular configuration upon deployment within a patient's body.

[0099] The device **10** may have an everted filamentary structure with a permeable shell **40** having a proximal end **32** and a distal end **34** in an expanded relaxed state. The permeable shell **40** has a substantially enclosed configuration for the embodiments shown. Some or all of the permeable shell **40** of the device **10** may be configured to substantially block or impede fluid flow or pressure into a vascular defect or otherwise isolate the vascular defect over some period of time after the device is deployed in an expanded state. The permeable shell **40** and device **10** generally also has a low profile, radially constrained state, as shown in FIG. **11**, with an elongated tubular or cylindrical configuration that includes the proximal end **32**, the distal end **34** and a longitudinal axis **46**. While in the radially constrained state, the elongate flexible filaments **14** of the permeable shell **40** may be disposed substantially parallel and in close lateral proximity to each other between the proximal end and distal end forming a substantially tubular or compressed cylindrical configuration.

[0100] Proximal ends **60** of at least some of the filaments **14** of the permeable shell **40** may be secured to the proximal hub **68** and distal ends **62** of at least some of the filaments **14** of the permeable shell **40** are secured to the distal hub **66**, with the proximal hub **68** and distal hub **66** being disposed substantially concentric to the longitudinal axis **46** as shown in FIG. **4**. The ends of the filaments **14** may be secured to the respective hubs **66** and **68** by any of the methods discussed above with respect to securement of the filament ends to each other, including the use of adhesives, solder, welding and the like. A middle portion **30** of the permeable shell **40** may have a first

transverse dimension with a low profile suitable for delivery from a microcatheter as shown in FIG. 11. Radial constraint on the device 10 may be applied by an inside surface of the inner lumen of a microcatheter, such as the distal end portion of the microcatheter 61 shown, or it may be applied by any other suitable mechanism that may be released in a controllable manner upon ejection of the device 10 from the distal end of the catheter. In FIG. 11 a proximal end or hub 68 of the device 10 is secured to a distal end of an elongate delivery apparatus 110 of a delivery system 112 disposed at the proximal hub 68 of the device 10.

[0101] Some device embodiments 10 having a braided or woven filamentary structure may be formed using about 10 filaments to about 300 filaments 14, more specifically, about 10 filaments to about 100 filaments 14, and even more specifically, about 60 filaments to about 80 filaments 14. Some embodiments of a permeable shell 40 may include about 70 filaments to about 300 filaments extending from the proximal end 32 to the distal end 34, more specifically, about 100 filaments to about 200 filaments extending from the proximal end 32 to the distal end 34. For some embodiments, the filaments 14 may have a transverse dimension or diameter of about 0.0008 inches to about 0.004 inches. The elongate resilient filaments 14 in some cases may have an outer transverse dimension or diameter of about 0.0005 inch to about 0.005 inch, more specifically, about 0.001 inch to about 0.003 inch, and in some cases about 0.0004 inches to about 0.002 inches. For some device embodiments 10 that include filaments 14 of different sizes, the large filaments 48 of the permeable shell 40 may have a transverse dimension or diameter that is about 0.001 inches to about 0.004 inches and the small filaments 50 may have a transverse dimension or diameter of about 0.0004 inches to about 0.0015 inches, more specifically, about 0.0004 inches to about 0.001 inches. In addition, a difference in transverse dimension or diameter between the small filaments 50 and the large filaments 48 may be less than about 0.004 inches, more specifically, less than about 0.0035 inches, and even more specifically, less than about 0.002 inches. For embodiments of permeable shells 40 that include filaments 14 of different sizes, the number of small filaments 50 of the permeable shell 40 relative to the number of large filaments 48 of the permeable shell 40 may be about 2 to 1 to about 15 to 1, more specifically, about 2 to 1 to about 12 to 1, and even more specifically, about 4 to 1 to about 8 to 1.

[0102] The expanded relaxed state of the permeable shell 40, as shown in FIG. 4, has an axially shortened configuration relative to the constrained state such that the proximal hub 68 is disposed closer to the distal hub 66 than in the constrained state. Both hubs 66 and 68 are disposed substantially concentric to the longitudinal axis 46 of the device and each filamentary element 14 forms a smooth arc between the proximal and distal hubs 66 and 68 with a reverse bend at each end. A longitudinal spacing between the proximal and distal hubs 66 and 68 of the permeable shell 40 in a deployed relaxed state may be about 25 percent to about 75 percent of the longitudinal spacing between the proximal and distal hubs 66 and 68 in the constrained cylindrical state, for some embodiments. The arc of the filaments 14 between the proximal and distal ends 32 and 34 may be configured such that a middle portion of each filament 14 has a second transverse dimension substantially greater than the first transverse dimension.

[0103] For some embodiments, the permeable shell 40 may have a first transverse dimension in a collapsed radially con-

strained state of about 0.2 mm to about 2 mm and a second transverse dimension in a relaxed expanded state of about 4 mm to about 30 mm. For some embodiments, the second transverse dimension of the permeable shell 40 in an expanded state may be about 2 times to about 150 times the first transverse dimension, more specifically, about 10 times to about 25 times the first or constrained transverse dimension. A longitudinal spacing between the proximal end 32 and distal end 34 of the permeable shell 40 in the relaxed expanded state may be about 25% percent to about 75% percent of the spacing between the proximal end 32 and distal end 34 in the constrained cylindrical state.

[0104] For some embodiments, a major transverse dimension of the permeable shell 40 in a relaxed expanded state may be about 4 mm to about 30 mm, more specifically, about 9 mm to about 15 mm, and even more specifically, about 4 mm to about 8 mm.

[0105] An arced portion of the filaments 14 of the permeable shell 40 may have a sinusoidal-like shape with a first or outer radius 88 and a second or inner radius 90 near the ends of the permeable shell 40 as shown in FIG. 6. This sinusoid-like or multiple curve shape may provide a concavity in the proximal end 32 that may reduce an obstruction of flow in a parent vessel adjacent a vascular defect. For some embodiments, the first radius 88 and second radius 90 of the permeable shell 40 may be between about 0.12 mm to about 3 mm. For some embodiments, the distance between the proximal end 32 and distal end 34 may be less than about 60% of the overall length of the permeable shell 40 for some embodiments. Such a configuration may allow for the distal end 34 to flex downward toward the proximal end 32 when the device 10 meets resistance at the distal end 34 and thus may provide longitudinal conformance. The filaments 14 may be shaped in some embodiments such that there are no portions that are without curvature over a distance of more than about 2 mm. Thus, for some embodiments, each filament 14 may have a substantially continuous curvature. This substantially continuous curvature may provide smooth deployment and may reduce the risk of vessel perforation. For some embodiments, one of the ends 32 or 34 may be retracted or everted to a greater extent than the other so as to be more longitudinally or axially conformal than the other end.

[0106] The first radius 88 and second radius 90 of the permeable shell 40 may be between about 0.12 mm to about 3 mm for some embodiments. For some embodiments, the distance between the proximal end 32 and distal end 34 may be more than about 60% of the overall length of the expanded permeable shell 40. Thus, the largest longitudinal distance between the inner surfaces may be about 60% to about 90% of the longitudinal length of the outer surfaces or the overall length of device 10. A gap between the hubs 66 and 68 at the proximal end 32 and distal end 34 may allow for the distal hub 66 to flex downward toward the proximal hub 68 when the device 10 meets resistance at the distal end and thus provides longitudinal conformance. The filaments 14 may be shaped such that there are no portions that are without curvature over a distance of more than about 2 mm. Thus, for some embodiments, each filament 14 may have a substantially continuous curvature. This substantially continuous curvature may provide smooth deployment and may reduce the risk of vessel perforation. The distal end 34 may be retracted or everted to a greater extent than the proximal end 32 such that the distal end portion of the permeable shell 40 may be more radially conformal than the proximal end portion. Conformability of a

distal end portion may provide better device conformance to irregular shaped aneurysms or other vascular defects. A convex surface of the device may flex inward forming a concave surface to conform to curvature of a vascular site. FIG. 10 shows an enlarged view of the filaments 14 disposed within a proximal hub 68 of the device 10 with the filaments 14 of two different sizes constrained and tightly packed by an outer ring of the proximal hub 68. The tether member 72 may optionally be disposed within a middle portion of the filaments 14 or within the cavity 70 of the proximal hub 68 proximal of the proximal ends 60 of the filaments 14 as shown in FIG. 6. The distal end of the tether 72 may be secured with a knot 92 formed in the distal end thereof which is mechanically captured in the cavity 70 of the proximal hub 68 formed by a proximal shoulder portion 94 of the proximal hub 68. The knotted distal end 92 of the tether 72 may also be secured by bonding or potting of the distal end of the tether 72 within the cavity 70 and optionally amongst the proximal ends 60 of the filaments 14 with mechanical compression, adhesive bonding, welding, soldering, brazing or the like. The tether embodiment 72 shown in FIG. 6 has a knotted distal end 92 potted in the cavity of the proximal hub 68 with an adhesive. Such a tether 72 may be a dissolvable, severable or releasable tether that may be part of a delivery apparatus 110 used to deploy the device 10 as shown in FIG. 11 and FIGS. 23-26. FIG. 10 also shows the large filaments 48 and small filaments 50 disposed within and constrained by the proximal hub 68 which may be configured to secure the large and small filaments 48 and 50 in place relative to each other within the outer ring of the proximal hub 68.

[0107] FIGS. 7 and 8 illustrate some configuration embodiments of braided filaments 14 of a permeable shell 40 of the device 10 for treatment of a patient's vasculature. The braid structure in each embodiment is shown with a circular shape 100 disposed within a pore 64 of a woven or braided structure with the circular shape 100 making contact with each adjacent filament segment. The pore opening size may be determined at least in part by the size of the filament elements 14 of the braid, the angle overlapping filaments make relative to each other and the picks per inch of the braid structure. For some embodiments, the cells or openings 64 may have an elongated substantially diamond shape as shown in FIG. 7, and the pores or openings 64 of the permeable shell 40 may have a substantially more square shape toward a middle portion 30 of the device 10, as shown in FIG. 8. The diamond shaped pores or openings 64 may have a length substantially greater than the width particularly near the hubs 66 and 68. In some embodiments, the ratio of diamond shaped pore or opening length to width may exceed a ratio of 3 to 1 for some cells. The diamond-shaped openings 64 may have lengths greater than the width thus having an aspect ratio, defined as Length/Width of greater than 1. The openings 64 near the hubs 66 and 68 may have substantially larger aspect ratios than those farther from the hubs as shown in FIG. 7. The aspect ratio of openings 64 adjacent the hubs may be greater than about 4 to 1. The aspect ratio of openings 64 near the largest diameter may be between about 0.75 to 1 and about 2 to 1 for some embodiments. For some embodiments, the aspect ratio of the openings 64 in the permeable shell 40 may be about 0.5 to 1 to about 2 to 1.

[0108] The pore size defined by the largest circular shapes 100 that may be disposed within openings 64 of the braided structure of the permeable shell 40 without displacing or distorting the filaments 14 surrounding the opening 64 may

range in size from about 0.005 inches to about 0.01 inches, more specifically, about 0.006 inches to about 0.009 inches, even more specifically, about 0.007 inches to about 0.008 inches for some embodiments. In addition, at least some of the openings 64 formed between adjacent filaments 14 of the permeable shell 40 of the device 10 may be configured to allow blood flow through the openings 64 only at a velocity below a thrombotic threshold velocity. For some embodiments, the largest openings 64 in the permeable shell structure 40 may be configured to allow blood flow through the openings 64 only at a velocity below a thrombotic threshold velocity. As discussed above, the pore size may be less than about 0.016 inches, more specifically, less than about 0.012 inches for some embodiments. For some embodiments, the openings 64 formed between adjacent filaments 14 may be about 0.005 inches to about 0.04 inches.

[0109] Referring to FIGS. 12-15, a delivery apparatus embodiment 110 of the delivery system 112 of FIG. 11 is shown in more detail. The apparatus 110 includes an elongate core wire 114 that extends from a proximal end 116 of the apparatus 110 to a distal section 118 of the apparatus 110 as shown in FIG. 12. The core wire 114 is configured to provide sufficient column strength to push a constrained device 10 for treatment of a patient's vasculature through an inner lumen 120 of the microcatheter 61 of the delivery system 112 as shown in FIG. 11. The core wire 114 also has sufficient tensile strength to withdraw or proximally retract the device 10 from a position outside the microcatheter 61 and axially within the inner lumen 120 of the microcatheter 61. The tether 72 that extends proximally from the proximal hub 68 is secured to the distal end of the core wire 114 with a length of shrinkable tubing 122 that is disposed over a portion of the tether 72 and a distal section of the core wire 114 and shrunk over both as shown in FIG. 13, although any other suitable means of securement may be used.

[0110] A heater coil 124 electrically coupled to a first conductor 126 and a second conductor 128 is disposed over a distal most portion of the tether 72. The heater coil 124 may also be covered with a length of polymer tubing 130 disposed over the heater coil 124 distal of the heat shrink tubing 122 that serves to act as a heat shield and minimize the leakage of heat from the heater coil 124 into the environment, such as the patient's blood stream, around the delivery apparatus 110. Once the heat shrink tubing 122 and insulating polymer tubing 130 have been secured to the distal section 118 of the apparatus 110, the proximal portion of the tether 72 disposed proximal of the heat shrink tubing 122 may be trimmed as shown in FIG. 13. An over coil 132 that extends from a distal end 134 of the delivery apparatus 110 to a proximal section 136 of the apparatus 110 may then be disposed over the heater coil 124, core wire 114, tether 72, first conductor 126 and second conductor 128 to hold these elements together, produce a low friction outer surface and maintain a desired flexibility of the delivery apparatus 110. The proximal section 136 of the apparatus 110 includes the proximal terminus of the over coil 132 which is disposed distal of a first contact 138 and second contact 140 which are circumferentially disposed about the proximal section 136 of the core wire 114, insulated therefrom, and electrically coupled to the first conductor 126 and second conductor 128, respectively as shown in FIG. 15.

[0111] The heater coil 124 may be configured to receive electric current supplied through the first conductor 126 and second conductor 128 from an electrical energy source 142 coupled to the first contact 138 and second contact 140 at the

proximal section 136 of the apparatus 110. The electrical current passed through the heater coil 124 heats the heater coil to a temperature above the melting point of the tether material 72 so as to melt the tether 72 and sever it upon deployment of the device 10.

[0112] Embodiments of the delivery apparatus 110 may generally have a length greater than the overall length of a microcatheter 61 to be used for the delivery system 112. This relationship allows the delivery apparatus 110 to extend, along with the device 10 secured to the distal end thereof, from the distal port of the inner lumen 120 of the microcatheter 61 while having sufficient length extending from a proximal end 150 of the microcatheter 61, shown in FIG. 17 discussed below, to enable manipulation thereof by a physician. For some embodiments, the length of the delivery apparatus 110 may be about 170 cm to about 200 cm. The core wire 114 may be made from any suitable high strength material such as stainless steel, NiTi alloy, or the like. Embodiments of the core wire 114 may have an outer diameter or transverse dimension of about 0.010 inch to about 0.015 inch. The over coil 132 may have an outer diameter or transverse dimension of about 0.018 inch to about 0.03 inch. Although the apparatus embodiment 110 shown in FIGS. 12-15 is activated by electrical energy passed through a conductor pair, a similar configuration that utilizes light energy passed through a fiber optic or any other suitable arrangement could be used to remotely heat a distal heating member or element such as the heater coil 124 to sever the distal portion of the tether 72. In addition, other delivery apparatus embodiments are discussed and incorporated herein that may also be used for any of the device embodiments 10 for treatment of a patient's vasculature discussed herein.

[0113] Other delivery and positioning system embodiments may provide for the ability to rotate a device for treatment of a patient's vasculature in-vivo without translating torque along the entire length of the delivery apparatus. Some embodiments for delivery and positioning of devices 10 are described in co-owned International PCT Patent Application No. PCT/US2008/065694 incorporated above. The delivery and positioning apparatus may include a distal rotating member that allows rotational positioning of the device. The delivery and positioning apparatus may include a distal rotating member which rotates an implant in-vivo without the transmission of torque along the entire length of the apparatus. Optionally, delivery system may also rotate the implant without the transmission of torque in the intermediate portion between the proximal end and the distal rotatable end. The delivery and positioning apparatus may be releasably secured to any suitable portion of the device for treatment of a patient's vasculature.

[0114] Device embodiments discussed herein may be releasable from any suitable flexible, elongate delivery apparatus or actuator such as a guidewire or guidewire-like structure. The release of device embodiments from such a delivery apparatus may be activated by a thermal mechanism, as discussed above, electrolytic mechanism, hydraulic mechanism, shape memory material mechanism, or any other mechanism known in the art of endovascular implant deployment.

[0115] Embodiments for deployment and release of therapeutic devices, such as deployment of embolic devices or stents within the vasculature of a patient, may include connecting such a device via a releasable connection to a distal portion of a pusher or other delivery apparatus member. The therapeutic device 10 may be detachably mounted to the

distal portion of the apparatus by a filamentary tether 72, string, thread, wire, suture, fiber, or the like, which may be referred to above as the tether. The tether 72 may be in the form of a monofilament, rod, ribbon, hollow tube, or the like. Some embodiments of the tether may have a diameter or maximum thickness of between about 0.05 mm and 0.2 mm. The tether 72 may be configured to be able to withstand a maximum tensile load of between about 0.5 kg and 5 kg. For some embodiments, due to the mass of the device 10 being deployed which may be substantially greater than some embolic devices, some known detachment devices may lack sufficient tensile strength to be used for some embodiments discussed herein. As such, it may be desirable to use small very high strength fibers for some tether embodiments having a "load at break" greater than about 15 Newtons. For some embodiments, a tether made from a material known as Dyneema Purity available from Royal DSM, Heerlen, Netherlands may be used.

[0116] The tether 72 may be severed by the input of energy such as electric current to a heating element causing release of the therapeutic device. For some embodiments, the heating element may be a coil of wire with high electrical resistivity such as a platinum-tungsten alloy. The tether member may pass through or be positioned adjacent the heater element. The heater may be contained substantially within the distal portion of the delivery apparatus to provide thermal insulation to reduce the potential for thermal damage to the surrounding tissues during detachment. In another embodiment, current may pass through the tether which also acts as a heating element.

[0117] Many materials may be used to make tether embodiments 72 including polymers, metals and composites thereof. One class of materials that may be useful for tethers includes polymers such as polyolefin, polyolefin elastomer such as polyethylene, polyester (PET), polyamide (Nylon), polyurethane, polypropylene, block copolymer such as PEBAX or Hytrel, and ethylene vinyl alcohol (EVA); or rubbery materials such as silicone, latex, and Kraton. In some cases, the polymer may also be cross-linked with radiation to manipulate its tensile strength and melt temperature. Another class of materials that may be used for tether embodiment may include metals such as nickel titanium alloy (Nitinol), gold, platinum, tantalum and steel. Other materials that may be useful for tether construction includes wholly aromatic polyester polymers which are liquid crystal polymers (LCP) that may provide high performance properties and are highly inert. A commercially available LCP polymer is Vectran, which is produced by Kuraray Co. (Tokyo, Japan). The selection of the material may depend on the melting or softening temperature, the power used for detachment, and the body treatment site. The tether may be joined to the implant and/or the pusher by crimping, welding, knot tying, soldering, adhesive bonding, or other means known in the art.

[0118] It should be noted also that many variations of filament and proximal hub construction such as is detailed above with regard to FIG. 10 may be used for useful embodiments of a device for treatment of a patient's vasculature 10. FIG. 16 shows an enlarged view in transverse cross section of a proximal hub configuration. For the embodiment shown, the filaments 14 are disposed within a proximal hub 68 or end portion of the device 10 with the filaments 14 constrained and tightly packed by an outer ring of the proximal hub 68. A tether member 72 may be disposed within a middle portion of the filaments 14 or within a cavity of the proximal hub 68

proximal of the proximal ends **60** of the filaments **14**. Such a tether **72** may be a dissolvable, severable or releasable tether that may be part of a release apparatus as discussed above used to deploy the device.

[0119] FIG. 16 illustrates in transverse cross section an embodiment of a proximal hub **68** showing the configuration of filaments which may be tightly packed and radially constrained by an inside surface of the proximal hub **68**. In some embodiments, the braided or woven structure of the permeable shell **40** formed from such filaments **14** may be constructed using a large number of small filaments. The number of filaments **14** may be greater than 125 and may also be between about 80 filaments and about 180 filaments. As discussed above, the total number of filaments **14** for some embodiments may be about 70 filaments to about 300 filaments, more specifically, about 100 filaments to about 200 filaments. In some embodiments, the braided structure of the permeable shell **40** may be constructed with two or more sizes of filaments **14**. For example, the structure may have several larger filaments that provide structural support and several smaller filaments that provide the desired pore size and density and thus flow resistance to achieve a thrombotic threshold velocity in some cases. For some embodiments, small filaments **50** of the permeable shell **40** may have a transverse dimension or diameter of about 0.0006 inches to about 0.002 inches for some embodiments and about 0.0004 inches to about 0.001 inches in other embodiments. The large filaments **48** may have a transverse dimension or diameter of about 0.0015 inches to about 0.004 inches in some embodiments and about 0.001 inches to about 0.004 inches in other embodiments. The filaments **14** may be braided in a plain weave that is one under, one over structure (shown in FIGS. 7 and 8) or a supplementary weave; more than one warp interlace with one or more than one weft. The pick count may be varied between about 25 and 200 picks per inch (PPI).

[0120] For some embodiments, the permeable shell **40** or portions thereof may be porous and may be highly permeable to liquids. In contrast to most vascular prosthesis fabrics or grafts which typically have a water permeability below 2,000 ml/min/cm² when measured at a pressure of 120 mmHg, the permeable shell **40** of some embodiments discussed herein may have a water permeability greater than about 2,000 ml/min/cm², in some cases greater than about 2,500 ml/min/cm². For some embodiments, water permeability of the permeable shell **40** or portions thereof may be between about 2,000 and 10,000 ml/min/cm², more specifically, about 2,000 ml/min/cm² to about 15,000 ml/min/cm², when measured at a pressure of 120 mmHg. Device embodiments and components thereof may include metals, polymers, biologic materials and composites thereof. Suitable metals include zirconium-based alloys, cobalt-chrome alloys, nickel-titanium alloys, platinum, tantalum, stainless steel, titanium, gold, and tungsten. Potentially suitable polymers include but are not limited to acrylics, silk, silicones, polyvinyl alcohol, polypropylene, polyvinyl alcohol, polyesters (e.g. polyethylene terephthalate or PET), PolyEtherEther Ketone (PEEK), polytetrafluoroethylene (PTFE), polycarbonate urethane (PCU) and polyurethane (PU). Device embodiments may include a material that degrades or is absorbed or eroded by the body. A bioresorbable (e.g. breaks down and is absorbed by a cell, tissue, or other mechanism within the body) or bioabsorbable (similar to bioresorbable) material may be used. Alternatively, a bioerodable (e.g., erodes or degrades over time by contact with surrounding tissue fluids, through cellular activ-

ity or other physiological degradation mechanisms), biodegradable (e.g., degrades over time by enzymatic or hydrolytic action, or other mechanism in the body), or dissolvable material may be employed. Each of these terms is interpreted to be interchangeable bioabsorbable polymer. Potentially suitable bioabsorbable materials include polylactic acid (PLA), poly(alpha-hydroxy acid) such as poly-L-lactide (PLLA), poly-D-lactide (PDLA), polyglycolide (PGA), polydioxanone, polycaprolactone, polygluconate, polylactic acid-polyethylene oxide copolymers, modified cellulose, collagen, poly(hydroxybutyrate), polyanhydride, polyphosphoester, poly(amino acids), or related copolymer materials. An absorbable composite fiber may be made by combining a reinforcement fiber made from a copolymer of about 18% glycolic acid and about 82% lactic acid with a matrix material consisting of a blend of the above copolymer with about 20% polycaprolactone (PCL).

[0121] In any of the suitable device embodiments **10** discussed herein, the permeable shell structure **40** may include one or more fixation elements or surfaces to facilitate fixation of the device within a blood vessel or other vascular site. The fixation elements may comprise hooks, barbs, protrusions, pores, microfeatures, texturing, bioadhesives or combinations thereof. Embodiments of the support structure may be fabricated from a tube of metal where portions are removed. The removal of material may be done by laser, electrical discharge machining (EDM), photochemical etching and traditional machining techniques. In any of the described embodiments, the support structure may be constructed with a plurality of wires, cut or etched from a sheet of a material, cut or etched from a tube or a combination thereof as in the art of vascular stent fabrication.

[0122] Permeable shell embodiments **40** may be formed at least in part of wire, ribbon, or other filamentary elements **14**. These filamentary elements **14** may have circular, elliptical, ovoid, square, rectangular, or triangular cross-sections. Permeable shell embodiments **40** may also be formed using conventional machining, laser cutting, electrical discharge machining (EDM) or photochemical machining (PCM). If made of a metal, it may be formed from either metallic tubes or sheet material.

[0123] Device embodiments **10** discussed herein may be delivered and deployed from a delivery and positioning system **112** that includes a microcatheter **61**, such as the type of microcatheter **61** that is known in the art of neurovascular navigation and therapy. Device embodiments for treatment of a patient's vasculature **10** may be elastically collapsed and restrained by a tube or other radial restraint, such as an inner lumen **120** of a microcatheter **61**, for delivery and deployment. The microcatheter **61** may generally be inserted through a small incision **152** accessing a peripheral blood vessel such as the femoral artery or brachial artery. The microcatheter **61** may be delivered or otherwise navigated to a desired treatment site **154** from a position outside the patient's body **156** over a guidewire **159** under fluoroscopy or by other suitable guiding methods. The guidewire **159** may be removed during such a procedure to allow insertion of the device **10** secured to a delivery apparatus **110** of the delivery system **112** through the inner lumen **120** of a microcatheter **61** in some cases. FIG. 17 illustrates a schematic view of a patient **158** undergoing treatment of a vascular defect **160** as shown in FIG. 18. An access sheath **162** is shown disposed within either a radial artery **164** or femoral artery **166** of the patient **158** with a delivery system **112** that includes a micro-

catheter **61** and delivery apparatus **110** disposed within the access sheath **162**. The delivery system **112** is shown extending distally into the vasculature of the patient's brain adjacent a vascular defect **160** in the patient's brain.

[0124] Access to a variety of blood vessels of a patient may be established, including arteries such as the femoral artery **166**, radial artery **164**, and the like in order to achieve percutaneous access to a vascular defect **160**. In general, the patient **158** may be prepared for surgery and the access artery is exposed via a small surgical incision **152** and access to the lumen is gained using the Seldinger technique where an introducing needle is used to place a wire over which a dilator or series of dilators dilates a vessel allowing an introducer sheath **162** to be inserted into the vessel. This would allow the device to be used percutaneously. With an introducer sheath **162** in place, a guiding catheter **168** is then used to provide a safe passageway from the entry site to a region near the target site **154** to be treated. For example, in treating a site in the human brain, a guiding catheter **168** would be chosen which would extend from the entry site **152** at the femoral artery up through the large arteries extending around the heart through the aortic arch, and downstream through one of the arteries extending from the upper side of the aorta such as the carotid artery **170**. Typically, a guidewire **159** and neurovascular microcatheter **61** are then placed through the guiding catheter **168** and advanced through the patient's vasculature, until a distal end **151** of the microcatheter **61** is disposed adjacent or within the target vascular defect **160**, such as an aneurysm. Exemplary guidewires **159** for neurovascular use include the Synchro2® made by Boston Scientific and the Glidewire Gold Neuro® made by MicroVention Terumo. Typical guidewire sizes may include 0.014 inches and 0.018 inches. Once the distal end **151** of the catheter **61** is positioned at the site, often by locating its distal end through the use of radiopaque marker material and fluoroscopy, the catheter is cleared. For example, if a guidewire **159** has been used to position the microcatheter **61**, it is withdrawn from the catheter **61** and then the implant delivery apparatus **110** is advanced through the microcatheter **61**.

[0125] Delivery and deployment of device embodiments **10** discussed herein may be carried out by first compressing the device **10** to a radially constrained and longitudinally flexible state as shown in FIG. **11**. The device **10** may then be delivered to a desired treatment site **154** while disposed within the microcatheter **61**, and then ejected or otherwise deployed from a distal end **151** of the microcatheter **61**. In other method embodiments, the microcatheter **61** may first be navigated to a desired treatment site **154** over a guidewire **159** or by other suitable navigation techniques. The distal end of the microcatheter **61** may be positioned such that a distal port of the microcatheter **61** is directed towards or disposed within a vascular defect **160** to be treated and the guidewire **159** withdrawn. The device **10** secured to a suitable delivery apparatus **110** may then be radially constrained, inserted into a proximal portion of the inner lumen **120** of the microcatheter **61** and distally advanced to the vascular defect **160** through the inner lumen **120**.

[0126] Once disposed within the vascular defect **160**, the device **10** may then be allowed to assume an expanded relaxed or partially relaxed state with the permeable shell **40** of the device spanning or partially spanning a portion of the vascular defect **160** or the entire vascular defect **160**. The device **10** may also be activated by the application of an energy source to assume an expanded deployed configuration once ejected

from the distal section of the microcatheter **61** for some embodiments. Once the device **10** is deployed at a desired treatment site **154**, the microcatheter **61** may then be withdrawn.

[0127] Some embodiments of devices for the treatment of a patient's vasculature **10** discussed herein may be directed to the treatment of specific types of defects of a patient's vasculature. For example, referring to FIG. **18**, an aneurysm **160** commonly referred to as a terminal aneurysm is shown in section. Terminal aneurysms occur typically at bifurcations in a patient's vasculature where blood flow, indicated by the arrows **172**, from a supply vessel splits into two or more branch vessels directed away from each other. The main flow of blood from the supply vessel **174**, such as a basilar artery, sometimes impinges on the vessel where the vessel diverges and where the aneurysm sack forms. Terminal aneurysms may have a well defined neck structure where the profile of the aneurysm **160** narrows adjacent the nominal vessel profile, but other terminal aneurysm embodiments may have a less defined neck structure or no neck structure. FIG. **19** illustrates a typical berry type aneurysm **160** in section where a portion of a wall of a nominal vessel section weakens and expands into a sack like structure ballooning away from the nominal vessel surface and profile. Some berry type aneurysms may have a well defined neck structure as shown in FIG. **19**, but others may have a less defined neck structure or none at all. FIG. **19** also shows some optional procedures wherein a stent **173** or other type of support has been deployed in the parent vessel **174** adjacent the aneurysm. Also, shown is embolic material **176** being deposited into the aneurysm **160** through a microcatheter **61**. Either or both of the stent **173** and embolic material **176** may be so deployed either before or after the deployment of a device for treatment of a patient's vasculature **10**. Prior to delivery and deployment of a device for treatment of a patient's vasculature **10**, it may be desirable for the treating physician to choose an appropriately sized device **10** to optimize the treatment results. Some embodiments of treatment may include estimating a volume of a vascular site or defect **160** to be treated and selecting a device **10** with a volume that is substantially the same volume or slightly over-sized relative to the volume of the vascular site or defect **160**. The volume of the vascular defect **160** to be occluded may be determined using three-dimensional angiography or other similar imaging techniques along with software which calculates the volume of a selected region. The amount of over-sizing may be between about 2% and 15% of the measured volume. In some embodiments, such as a very irregular shaped aneurysm, it may be desirable to under-size the volume of the device **10**. Small lobes or "daughter aneurysms" may be excluded from the volume, defining a truncated volume which may be only partially filled by the device without affecting the outcome. A device **10** deployed within such an irregularly shaped aneurysm **160** is shown in FIG. **28** discussed below. Such a method embodiment may also include implanting or deploying the device **10** so that the vascular defect **160** is substantially filled volumetrically by a combination of device and blood contained therein. The device **10** may be configured to be sufficiently conformal to adapt to irregular shaped vascular defects **160** so that at least about 75%, in some cases about 80%, of the vascular defect volume is occluded by a combination of device **10** and blood contained therein.

[0128] In particular, for some treatment embodiments, it may be desirable to choose a device **10** that is properly over-

sized in a transverse dimension so as to achieve a desired conformance, radial force and fit after deployment of the device **10**. FIGS. **20-22** illustrate a schematic representation of how a device **10** may be chosen for a proper fit after deployment that is initially oversized in a transverse dimension by at least about 10% of the largest transverse dimension of the vascular defect **160** and sometimes up to about 100% of the largest transverse dimension. For some embodiments, the device **10** may be oversized a small amount (e.g. less than about 1.5 mm) in relation to measured dimensions for the width, height or neck diameter of the vascular defect **160**.

[0129] In FIG. **20**, a vascular defect **160** in the form of a cerebral aneurysm is shown with horizontal arrows **180** and vertical arrows **182** indicating the approximate largest interior dimensions of the defect **160**. Arrow **180** extending horizontally indicates the largest transverse dimension of the defect **160**. In FIG. **21**, a dashed outline **184** of a device for treatment of the vascular defect **10** is shown superimposed over the vascular defect **160** of FIG. **20** illustrating how a device **10** that has been chosen to be approximately 20% oversized in a transverse dimension would look in its unconstrained, relaxed state. FIG. **22** illustrates how the device **10** which is indicated by the dashed line **184** of FIG. **21** might conform to the interior surface of the vascular defect **160** after deployment whereby the nominal transverse dimension of the device **10** in a relaxed unconstrained state has now been slightly constrained by the inward radial force **185** exerted by the vascular defect **160** on the device **10**. In response, as the filaments **14** of the device **10** and thus the permeable shell **40** made therefrom have a constant length, the device **10** has assumed a slightly elongated shape in the axial or longitudinal axis of the device **10** so as to elongate and better fill the interior volume of the defect **160** as indicated by the downward arrow **186** in FIG. **22**.

[0130] Once a properly sized device **10** has been selected, the delivery and deployment process may then proceed. It should also be noted also that the properties of the device embodiments **10** and delivery system embodiments **112** discussed herein generally allow for retraction of a device **10** after initial deployment into a defect **160**, but before detachment of the device **10**. Therefore, it may also be possible and desirable to withdraw or retrieve an initially deployed device **10** after the fit within the defect **160** has been evaluated in favor of a differently sized device **10**. An example of a terminal aneurysm **160** is shown in FIG. **23** in section. The tip **151** of a catheter, such as a microcatheter **61** may be advanced into or adjacent the vascular site or defect **160** (e.g. aneurysm) as shown in FIG. **24**. For some embodiments, an embolic coil or other vaso-occlusive device or material **176** (as shown for example in FIG. **19**) may optionally be placed within the aneurysm **160** to provide a framework for receiving the device **10**. In addition, a stent **173** may be placed within a parent vessel **174** of some aneurysms substantially crossing the aneurysm neck prior to or during delivery of devices for treatment of a patient's vasculature discussed herein (also as shown for example in FIG. **19**). An example of a suitable microcatheter **61** having an inner lumen diameter of about 0.020 inches to about 0.022 inches is the Rapid Transit® manufactured by Cordis Corporation. Examples of some suitable microcatheters **61** may include microcatheters having an inner lumen diameter of about 0.026 inch to about 0.028 inch, such as the Rebar® by Ev3 Company, the Renegade Hi-Flow® by Boston Scientific Corporation, and the Mass Transit® by Cordis Corporation. Suitable microcatheters having

an inner lumen diameter of about 0.031 inch to about 0.033 inch may include the Marksmen® by Chestnut Medical Technologies, Inc. and the Vasco **280** by Balt Extrusion. A suitable microcatheter **61** having an inner lumen diameter of about 0.039 inch to about 0.041 inch includes the Vasco **35** by Balt Extrusion. These microcatheters **61** are listed as exemplary embodiments only, other suitable microcatheters may also be used with any of the embodiments discussed herein.

[0131] Detachment of the device **10** from the delivery apparatus **110** may be controlled by a control switch **188** disposed at a proximal end of the delivery system **112**, which may also be coupled to an energy source **142**, which severs the tether **72** that secures the proximal hub **68** of the device **10** to the delivery apparatus **110**. While disposed within the microcatheter **61** or other suitable delivery system **112**, as shown in FIG. **11**, the filaments **14** of the permeable shell **40** may take on an elongated, non-everted configuration substantially parallel to each other and a longitudinal axis of the catheter **61**. Once the device **10** is pushed out of the distal port of the microcatheter **61**, or the radial constraint is otherwise removed, the distal ends **62** of the filaments **14** may then axially contract towards each other so as to assume the globular everted configuration within the vascular defect **160** as shown in FIG. **25**.

[0132] The device **10** may be inserted through the microcatheter **61** such that the catheter lumen **120** restrains radial expansion of the device **10** during delivery. Once the distal tip or deployment port of the delivery system **112** is positioned in a desirable location adjacent or within a vascular defect **160**, the device **10** may be deployed out the distal end of the catheter **61** thus allowing the device to begin to radially expand as shown in FIG. **25**. As the device **10** emerges from the distal end of the delivery system **112**, the device **10** expands to an expanded state within the vascular defect **160**, but may be at least partially constrained by an interior surface of the vascular defect **160**.

[0133] Upon full deployment, radial expansion of the device **10** may serve to secure the device **10** within the vascular defect **160** and also deploy the permeable shell **40** across at least a portion of an opening **190** (e.g. aneurysm neck) so as to at least partially isolate the vascular defect **160** from flow, pressure or both of the patient's vasculature adjacent the vascular defect **160** as shown in FIG. **26**. The conformability of the device **10**, particularly in the neck region **190** may provide for improved sealing. For some embodiments, once deployed, the permeable shell **40** may substantially slow flow of fluids and impede flow into the vascular site and thus reduce pressure within the vascular defect **160**. For some embodiments, the device **10** may be implanted substantially within the vascular defect **160**, however, in some embodiments, a portion of the device **10** may extend into the defect opening or neck **190** or into branch vessels.

[0134] One exemplary case study that has been conducted includes a procedure performed on a female canine where an aneurysm was surgically created in the subject canine. The target aneurysm prior to treatment had a maximum transverse dimension of about 8 mm, a length of about 10 mm and a neck measurement of about 5.6 mm. The device **10** deployed included a permeable shell **40** formed of 144 resilient filaments having a transverse diameter of about 0.0015 inches braided into a globular structure having a transverse dimension of about 10 mm and a longitudinal length of about 7 mm in a relaxed expanded state. The maximum size 100 of the pores **64** of the expanded deployed permeable shell **40** was about 0.013 inches. The device was delivered to the target

aneurysm using a 5 Fr. Guider Softip XF guide catheter made by Boston Scientific. The maximum size 100 of the pores 64 of the portion of the expanded deployed permeable shell 40 that spanned the neck of the aneurysm again was about 0.013 inches. Five minutes after detachment from the delivery system, the device 10 had produced acute occlusion of the aneurysm.

[0135] Another exemplary case study conducted involved treatment of a surgically created aneurysm in a New Zealand White Rabbit. The target aneurysm prior to treatment had a maximum transverse dimension of about 3.6 mm, length of about 5.8 mm and a neck measurement of about 3.4 mm. The device 10 deployed included a permeable shell formed of 144 resilient filaments having a transverse diameter of about 0.001 inches braided into a globular structure having a transverse dimension of about 4 mm and a length of about 5 mm in a relaxed expanded state. The pore size 100 of the portion of the braided mesh of the expanded deployed permeable shell 40 that was configured to span the neck of the vascular defect was about 0.005 inches. The device was delivered to the surgically created aneurysm with a 5 Fr. Envoy STR guide catheter manufactured by Cordis Neurovascular. A Renegade Hi-Flo microcatheter manufactured by Boston Scientific having an inner lumen diameter of about 0.027 inches was then inserted through the guide catheter and served as a conduit for delivery of the device 10 secured to a distal end of a delivery apparatus. Once the device 10 was deployed within the vascular defect 160, the vascular defect 160 achieved at least partial occlusion at 5 minutes from implantation. However, due to the sensitivity of the subject animal to angiographic injection and measurement, no further data was taken during the procedure. Complete occlusion was observed for the device when examined at 3 weeks from the procedure.

[0136] For some embodiments, as discussed above, the device 10 may be manipulated by the user to position the device 10 within the vascular site or defect 160 during or after deployment but prior to detachment. For some embodiments, the device 10 may be rotated in order to achieve a desired position of the device 10 and, more specifically, a desired position of the permeable shell 40, prior to or during deployment of the device 10. For some embodiments, the device 10 may be rotated about a longitudinal axis of the delivery system 112 with or without the transmission or manifestation of torque being exhibited along a middle portion of a delivery catheter being used for the delivery. It may be desirable in some circumstances to determine whether acute occlusion of the vascular defect 160 has occurred prior to detachment of the device 10 from the delivery apparatus 110 of the delivery system 112. These delivery and deployment methods may be used for deployment within berry aneurysms, terminal aneurysms, or any other suitable vascular defect embodiments 160. Some method embodiments include deploying the device 10 at a confluence of three vessels of the patient's vasculature that form a bifurcation such that the permeable shell 40 of the device 10 substantially covers the neck of a terminal aneurysm. Once the physician is satisfied with the deployment, size and position of the device 10, the device 10 may then be detached by actuation of the control switch 188 by the methods described above and shown in FIG. 26. Thereafter, the device 10 is in an implanted state within the vascular defect 160 to effect treatment thereof.

[0137] FIG. 27 illustrates another configuration of a deployed and implanted device in a patient's vascular defect 160. While the implantation configuration shown in FIG. 26

indicates a configuration whereby the longitudinal axis 46 of the device 10 is substantially aligned with a longitudinal axis of the defect 160, other suitable and clinically effective implantation embodiments may be used. For example, FIG. 27 shows an implantation embodiment whereby the longitudinal axis 46 of the implanted device 10 is canted at an angle of about 10 degrees to about 90 degrees relative to a longitudinal axis of the target vascular defect 160. Such an alternative implantation configuration may also be useful in achieving a desired clinical outcome with acute occlusion of the vascular defect 160 in some cases and restoration of normal blood flow adjacent the treated vascular defect. FIG. 28 illustrates a device 10 implanted in an irregularly shaped vascular defect 160. The aneurysm 160 shown has at least two distinct lobes 192 extending from the main aneurysm cavity. The two lobes 192 shown are unfilled by the deployed vascular device 10, yet the lobes 192 are still isolated from the parent vessel of the patient's body due to the occlusion of the aneurysm neck portion 190.

[0138] Markers, such as radiopaque markers, on the device 10 or delivery system 112 may be used in conjunction with external imaging equipment (e.g. x-ray) to facilitate positioning of the device or delivery system during deployment. Once the device is properly positioned, the device 10 may be detached by the user. For some embodiments, the detachment of the device 10 from the delivery apparatus 110 of the delivery system 112 may be affected by the delivery of energy (e.g. heat, radiofrequency, ultrasound, vibrational, or laser) to a junction or release mechanism between the device 10 and the delivery apparatus 110. Once the device 10 has been detached, the delivery system 112 may be withdrawn from the patient's vasculature or patient's body 158. For some embodiments, a stent 173 may be placed within the parent vessel substantially crossing the aneurysm neck 190 after delivery of the device 10 as shown in FIG. 19 for illustration.

[0139] For some embodiments, a biologically active agent or a passive therapeutic agent may be released from a responsive material component of the device 10. The agent release may be affected by one or more of the body's environmental parameters or energy may be delivered (from an internal or external source) to the device 10. Hemostasis may occur within the vascular defect 160 as a result of the isolation of the vascular defect 160, ultimately leading to clotting and substantial occlusion of the vascular defect 160 by a combination of thrombotic material and the device 10. For some embodiments, thrombosis within the vascular defect 160 may be facilitated by agents released from the device 10 and/or drugs or other therapeutic agents delivered to the patient.

[0140] For some embodiments, once the device 10 has been deployed, the attachment of platelets to the permeable shell 40 may be inhibited and the formation of clot within an interior space of the vascular defect 160, device, or both promoted or otherwise facilitated with a suitable choice of thrombogenic coatings, anti-thrombogenic coatings or any other suitable coatings (not shown) which may be disposed on any portion of the device 10 for some embodiments, including an outer surface of the filaments 14 or the hubs 66 and 68. Such a coating or coatings may be applied to any suitable portion of the permeable shell 40. Energy forms may also be applied through the delivery apparatus 110 and/or a separate catheter to facilitate fixation and/or healing of the device 10 adjacent the vascular defect 160 for some embodiments. One or more embolic devices or embolic material 176 may also optionally be delivered into the vascular defect 160 adjacent

permeable shell portion that spans the neck or opening **190** of the vascular defect **160** after the device **10** has been deployed. For some embodiments, a stent or stent-like support device **173** may be implanted or deployed in a parent vessel adjacent the defect **160** such that it spans across the vascular defect **160** prior to or after deployment of the vascular defect treatment device **10**.

[0141] In any of the above embodiments, the device **10** may have sufficient radial compliance so as to be readily retrievable or retractable into a typical microcatheter **61**. The proximal portion of the device **10**, or the device as a whole for some embodiments, may be engineered or modified by the use of reduced diameter filaments, tapered filaments, or filaments oriented for radial flexure so that the device **10** is retractable into a tube that has an internal diameter that is less than about 0.7 mm, using a retraction force less than about 2.7 Newtons (0.6 lbf) force. The force for retrieving the device **10** into a microcatheter **61** may be between about 0.8 Newtons (0.18 lbf) and about 2.25 Newtons (0.5 lbf).

[0142] Engagement of the permeable shell **40** with tissue of an inner surface of a vascular defect **160**, when in an expanded relaxed state, may be achieved by the exertion of an outward radial force against tissue of the inside surface of the cavity of the patient's vascular defect **160** as shown in FIG. **29**. A similar outward radial force may also be applied by a proximal end portion and permeable shell **40** of the device **10** so as to engage the permeable shell **40** with an inside surface or adjacent tissue of the vascular defect **160**. Such forces may be exerted in some embodiments wherein the nominal outer transverse dimension or diameter of the permeable shell **40** in the relaxed unconstrained state is larger than the nominal inner transverse dimension of the vascular defect **160** within which the device **10** is being deployed, i.e., oversizing as discussed above. The elastic resiliency of the permeable shell **40** and filaments **14** thereof may be achieved by an appropriate selection of materials, such as superelastic alloys, including nickel titanium alloys, or any other suitable material for some embodiments. The conformability of a proximal portion of the permeable shell **40** of the device **10** may be such that it will readily ovalize to adapt to the shape and size of an aneurysm neck **190**, as shown in FIGS. **20-22**, thus providing a good seal and barrier to flow around the device. Thus the device **10** may achieve a good seal, substantially preventing flow around the device without the need for fixation members that protrude into the parent vessel.

[0143] Some implanted device embodiments **10** have the ends of the filaments **14** of the permeable shell **40** disposed even with or just within a plane formed by the apices of the filaments disposed adjacent to the ends. Some embodiments of the device **10** may also include a sealing member disposed within or about a perimeter zone **198** or other suitable portion of the permeable shell **40** and be configured to facilitate the disruption of flow, a fibrotic tissue response, or physically form a seal between the permeable shell **40** and a surface of the patient's vasculature. The sealing member may comprise coatings, fibers or surface treatments as described herein. The sealing member may be in a part or all of an area of the periphery of the device adjacent where the device contacts the wall of the aneurysm near the aneurysm neck (sealing zone **198**) as shown in FIGS. **29** and **30**. The zone may extend from about the apex of the outer proximal end radius **88** for a distance up to about 20% of the height of the expanded device **10**. The sealing zone **198** may include between about 5% and 30% of the device **10** surface area. Since the flow of blood into

an aneurysm **160** generally favors one side of the opening, the sealing member may be incorporated in or attached to the permeable shell **40** structure throughout the peripheral area (sealing zone **198**) shown in FIG. **30**. Some embodiments of the sealing member may include a swellable polymer. In some embodiments, the sealing member may include or bioactive material or agent such as a biologic material or biodegradable, bioresorbable or other bioactive polymer or copolymers thereof.

[0144] Any embodiment of devices for treatment of a patient's vasculature **10**, delivery system **112** for such devices **10** or both discussed herein may be adapted to deliver energy to the device for treatment of a patient's vasculature or to tissue surrounding the device **10** at the implant site for the purpose of facilitating fixation of a device **10**, healing of tissue adjacent the device or both. In some embodiments, energy may be delivered through a delivery system **112** to the device **10** for treatment of a patient's vasculature such that the device **10** is heated. In some embodiments, energy may be delivered via a separate elongate instrument (e.g. catheter, not shown) to the device **10** for treatment of a patient's vasculature and/or surrounding tissue at the site of the implant **154**. Examples of energy embodiments that may be delivered include but are not limited to light energy, thermal or vibration energy, electromagnetic energy, radio frequency energy and ultrasonic energy. For some embodiments, energy delivered to the device **10** may trigger the release of chemical or biologic agents to promote fixation of a device for treatment of a patient's vasculature **10** to a patient's tissue, healing of tissue disposed adjacent such a device **10** or both.

[0145] The permeable shell **40** of some device embodiments **10** may also be configured to react to the delivery of energy to effect a change in the mechanical or structural characteristics, deliver drugs or other bioactive agents or transfer heat to the surrounding tissue. For example, some device embodiments **10** may be made softer or more rigid from the use of materials that change properties when exposed to electromagnetic energy (e.g. heat, light, or radio frequency energy). In some cases, the permeable shell **40** may include a polymer that reacts in response to physiologic fluids by expanding. An exemplary material is described by Cox in U.S. Patent Application No. 2004/0186562, filed Jan. 22, 2004, titled "Aneurysm Treatment Device and Method of Use", which is incorporated by reference herein in its entirety.

[0146] Device embodiments **10** and components thereof discussed herein may take on a large variety of configurations to achieve specific or generally desirable clinical results. In some device embodiments **10**, the start of the braided structure of the permeable shell **40** may be delayed from the proximal hub **68** so that the filaments **14** emanate from the proximal hub **68** in a spoke-like radial fashion as shown in the proximal end view of a device in FIG. **31**. A flattened analog version of the braid pattern of FIG. **31** is also shown in FIG. **33**. This configuration may result in a smaller width gap between the filaments **14** at a given radial distance from the proximal hub **68** relative to a fully braided configuration, the flattened analog pattern of which is shown in FIG. **34**. This may provide better flow disruption and promote hemostasis in the area of the device **10** that may be subjected to the highest flow rates. FIG. **32** illustrates a flattened analog representation of a non-braided filament structure for reference.

[0147] The woven structure may include a portion where the weave or braid of the filaments **14** is interrupted as shown in a flat pattern analog pattern in FIG. **35**. In the interrupted

region, the filaments **14** may be substantially parallel to each other. The interrupted area may provide a region with different mechanical characteristics such as radial stiffness and/or compliance. Further, the interrupted region may allow for the addition of non-structural fibers or sealing members **200** as described herein or other elements to facilitate fixation, healing, fibrosis or thrombosis. The interrupted region may be within, part of or adjacent to the sealing member zone **198** as shown in FIGS. **29** and **30**. The interrupted region may be less than about 50% of the surface area and may be between about 5% and 25% of the surface area.

[0148] In some embodiments, filamentary or fibrous members that are substantially non-structural may be attached or interwoven into the structural filaments of a portion of the permeable shell to increase a resistance to the flow of blood through the permeable shell structure **40**. In some embodiments, a plurality of fibers **200** may be attached on the inner surface of the permeable shell **40** near the proximal hub **68** as shown in FIG. **36**. The fibrous members **200** may be the fibers that form the detachment system tether for some embodiments. In some embodiments, one or more fibers **200** may be interwoven into the permeable shell filaments **14** as shown in FIG. **37**. The non-structural fibers **200**, which may be microfibers or any other suitable fibers, may be polymeric. The non-structural fibers **200** may include, but not limited to, any of the fibers or microfibers discussed or incorporated herein.

[0149] In some cases, device embodiments for treatment of a patient's vasculature **10** may generally be fabricated by braiding a substantially tubular braided structure with filamentary elements **14**, forming the braided tubular structure into a desired shape, and heat setting the braided formed filaments into the desired shape. Once so formed, the ends of the elongate resilient filaments **14** may then be secured together relative to each other by any of the methods discussed above and proximal and distal hubs **66** and **68** added.

[0150] Such a braiding process may be carried out by automated machine fabrication or may also be performed by hand. An embodiment of a process for braiding a tubular braided structure by a manual process is shown in FIG. **38**. A plurality of elongate resilient filaments **14** are secured at one end of an elongate cylindrical braiding mandrel **202** by a constraining band **204**. The band **204** may include any suitable structure that secured the ends of the filaments **14** relative to the mandrel **202** such as a band of adhesive tape, an elastic band, an annular clamp or the like. The loose ends of the filaments **14** opposite the secured ends are being manipulated in a braided or woven pattern as indicated by the arrows **206** to achieve a one over-one under braid pattern for generation of a braided tubular member **208**. As discussed above, although a one over-one under simple braid pattern is shown and discussed, other braid or weave patterns may also be used. One such example of another braid configuration may include a two over-one under pattern. FIG. **39** illustrates the braided tubular member **208** taking shape and lengthening as the braiding process continues as indicated by the arrows **206** in FIG. **39**. Once the braided tubular member **208** achieves sufficient length, it may be removed from the braiding mandrel **202** and positioned within a shaping fixture such as the shaping fixture embodiments shown in FIGS. **40** and **41**.

[0151] FIG. **40** shows the tubular braided member **208** disposed over an internal rod mandrel **210** that extends through central lumens of an internal ball mandrel **212** and a pair of opposed recessed end forming mandrels **214**. The tubular braided member **208** is also disposed over an outer surface of

the internal ball mandrel **212** and within an inner lumen of each of the end forming mandrels **214**. In order to hold the braided tubular member **208** onto an outer surface contour of the internal ball mandrel **212**, including the recessed ends **216** thereof, the end forming mandrels **214** are configured to be pushed against and into the recessed ends **216** of the internal ball mandrel **212** such that the inside surface of the braided tubular member **208** is held against the outer contour of the internal ball mandrel **212** and fixed in place. This entire fixture **220** with the inside surface of the braided tubular structure **208** held against the outside surface of the internal ball mandrel **212** may then be subjected to an appropriate heat treatment such that the resilient filaments **14** of the braided tubular member **208** assume or are otherwise shape-set to the outer contour of the central ball mandrel **212**. In some embodiments, the filamentary elements **14** of the permeable shell **40** may be held by a fixture configured to hold the permeable shell **40** in a desired shape and heated to about 475-525 degrees C. for about 5-10 minutes to shape-set the structure.

[0152] The central ball mandrel **212** may be configured to have any desired shape so as to produce a shape set tubular braided member **208** that forms a permeable shell **40** having a desired shape and size such as the globular configuration of the device **10** of FIGS. **3-6** above, or any other suitable configuration. As such, the central ball mandrel **212** may also be a globular-shaped ball with recesses in opposing sides for the hubs **66** and **68** that is placed inside the tubular braid **208**. A mold or molds that have one or more pieces that are assembled to form a cavity with the desired device shape may also be used in conjunction with or in place of the end forming mandrels **214**. Once the heat set process is complete, fibers, coatings, surface treatments may be added to certain filaments, portions of filaments, or all of the permeable shell **40** structure that results. Further, for some embodiments of device processing, the permeable shell **40** may be formed as discussed above by securing proximal ends **60** and distal ends **62** of elongate filamentary elements **14**, or to respective proximal and distal hubs **66** and **68**.

[0153] FIG. **41** shows another embodiment of a fixture for shape setting the permeable shell **40** of a device for treatment of a patient's vasculature. The fixture embodiment **230** of FIG. **41** may be used in essentially the same manner as the fixture embodiment **220** of FIG. **40**, except that instead of a central ball mandrel **212**, an internal tube mandrel **232** is used in conjunction with an external tube restraint **234** in order to hold the shape of the braided tubular member **208** during the heat setting process. More specifically, the tubular braided member **208** is disposed over an internal rod mandrel **210** that extends through central lumens of the internal tube mandrel **232** and a pair of opposed recessed end forming mandrels **214**. The tubular braided member **208** is also disposed over an outer surface of the internal tube mandrel **232** and within an inner lumen of each of the end forming mandrels **214**.

[0154] In order to hold the braided tubular member **208** into a desired shape, including the recessed ends thereof, the end forming mandrels **214** are configured to be pushed against and into recessed ends **238** of the internal tube mandrel **232** such that the inside surface of the braided tubular member **208** is held against the outer contour of the internal tube mandrel **232** and fixed in place at the ends of the tube mandrel **232**. Between the ends of the tube mandrel **232**, the braided tubular member **208** radially expands outwardly until it touches and is radially constrained by an inside surface of an external tube

mandrel **234**. The combination of axial restraint and securement of the braided tubular member **208** at the ends of the internal tube mandrel **232** in conjunction with the inward radial restraint on an outside surface of the braided tubular member **208** disposed between the proximal and distal ends thereof, may be configured to produce a desired globular configuration suitable for the permeable shell **40** of the device **10**.

[0155] Once again, this entire fixture **230** with the inside surface of the ends of the braided tubular structure **208** held against the outside surface of the ends of the internal tube mandrel **232** and an outside surface of the braided tubular member **208** radially constrained by an inside surface **233** of the external tube member **234**, may then be subjected to an appropriate heat treatment. The heat treatment may be configured such that the resilient filaments **14** of the braided tubular member **208** assume or are otherwise shape-set to the globular contour of the filaments **14** generated by the fixture **230**. In some embodiments, the filamentary elements **14** of the permeable shell **40** may be held by a fixture configured to hold the braided tubular member **208** in a desired shape and heated to about 475-525 degrees C. for about 5-10 minutes to shape-set the structure. The internal tube mandrel **232** and inside surface **233** of the external tube member **234** may be so configured to have any desired shape so as to produce a shape set tubular braided member **208** that forms a permeable shell **40** having a desired shape and size such as the globular configuration of the device of FIGS. 3-6 above, or any other suitable configuration. For some embodiments, material may be attached to filaments **14** of the permeable shell **40** of a device **10** such that it substantially reduces the size of the fenestrations, cells or pores **64** between filaments **14** and thus reduces the porosity in that area. For example, coating embodiments may be disposed on portions of the filaments **14** to create small fenestrations or cells and thus higher density of the permeable shell **40**. Active materials such as a responsive hydrogel may be attached or otherwise incorporated into permeable shell **40** of some embodiments such that it swells upon contact with liquids over time to reduce the porosity of the permeable shell **40**.

[0156] Device embodiments **10** discussed herein may be coated with various polymers to enhance its performance, fixation and/or biocompatibility. In addition, device embodiments **10** may be made of various biomaterials known in the art of implant devices including but not limited to polymers, metals, biological materials and composites thereof. Device embodiments discussed herein may include cells and/or other biologic material to promote healing. Device embodiments discussed herein may also be constructed to provide the elution or delivery of one or more beneficial drugs, other bioactive substances or both into the blood or the surrounding tissue.

[0157] Permeable shell embodiments **40** of devices for treatment of a patient's vasculature **10** may include multiple layers. A first or outer layer may be constructed from a material with low bioactivity and hemocompatibility so as to minimize platelet aggregation or attachment and thus the propensity to form clot and thrombus. Optionally, an outer layer may be coated or incorporate an antithrombogenic agent such as heparin or other antithrombogenic agents described herein or known in the art. One or more inner layers disposed towards the vascular defect in a deployed state relative to the first layer may be constructed of materials that have greater bioactivity and/or promote clotting and thus enhance the formation of an

occlusive mass of clot and device within the vascular defect. Some materials that have been shown to have bioactivity and/or promote clotting include silk, polylactic acid (PLA), polyglycolic acid (PGA), collagen, alginate, fibrin, fibrinogen, fibronectin, Methylcellulose, gelatin, Small Intestinal Submucosa (SIS), poly-N-acetylglucosamine and copolymers or composites thereof.

[0158] Bioactive agents suitable for use in the embodiments discussed herein may include those having a specific action within the body as well as those having nonspecific actions. Specific action agents are typically proteinaceous, including thrombogenic types and/or forms of collagen, thrombin and fibrinogen (each of which may provide an optimal combination of activity and cost), as well as elastin and von Willebrand factor (which may tend to be less active and/or expensive agents), and active portions and domains of each of these agents. Thrombogenic proteins typically act by means of a specific interaction with either platelets or enzymes that participate in a cascade of events leading eventually to clot formation. Agents having nonspecific thrombogenic action are generally positively charged molecules, e.g., polymeric molecules such as chitosan, polylysine, poly(ethylenimine) or acrylics polymerized from acrylamide or methacrylamide which incorporate positively-charged groups in the form of primary, secondary, or tertiary amines or quaternary salts, or non-polymeric agents such as (tridodecylmethylammonium chloride). Positively charged hemostatic agents promote clot formation by a non-specific mechanism, which includes the physical adsorption of platelets via ionic interactions between the negative charges on the surfaces of the platelets and the positive charges of the agents themselves. Device embodiments **10** herein may include a surface treatment or coating on a portion, side or all surfaces that promotes or inhibits thrombosis, clotting, healing or other embolization performance measure. The surface treatment or coating may be a synthetic, biologic or combination thereof. For some embodiments, at least a portion of an inner surface of the permeable shell **40** may have a surface treatment or coating made of a biodegradable or bioresorbable material such as a polylactide, polyglycolide or a copolymer thereof. Another surface treatment or coating material which may enhance the embolization performance of a device includes a polysaccharide such as an alginate based material. Some coating embodiments may include extracellular matrix proteins such as ECM proteins. One example of such a coating may be Finale Prohealing coating which is commercially available from Surmodics Inc. Eden Prairie, Minn. Another exemplary coating may be Polyzene-F which is commercially available from Celonovo BioSciences, Inc., Newnan, Ga. In some embodiments, the coatings may be applied with a thickness that is less than about 25% of a transverse dimension of the filaments **14**.

[0159] Antiplatelet agents may include aspirin, glycoprotein I b/IIIa receptor inhibitors (including, abciximab, eptifibatid, tirofiban, lamifiban, fradafiban, cromafiban, toxfiban, XV454, lefradafiban, klerval, lotrafiban, orbofiban, and xemilofiban), dipyridamole, apo-dipyridamole, persantine, prostacyclin, ticlopidine, clopidogrel, cromafiban, cilostazol, and nitric oxide. To deliver nitric oxide, device embodiments may include a polymer that releases nitric oxide. Device embodiments **10** may also deliver or include an anticoagulant such as heparin, low molecular weight heparin, hirudin, warfarin, bivalirudin, hirudin, argatroban, forskolin, ximelagatran, vaproprost, prostacyclin and prostacyclin analogues, dex-

tran, synthetic antithrombin, Vasoflux, argatroban, efegatran, tick anticoagulant peptide, Ppack, HMG-CoA reductase inhibitors, and thromboxane A2 receptor inhibitors.

[0160] In some embodiments, the permeable shell **40** of a device **10** may be coated with a composition that may include nanoscale structured materials or precursors thereof (e.g., self-assembling peptides). The peptides may have with alternating hydrophilic and hydrophobic monomers that allow them to self assemble under physiological conditions. The composition may comprise a sequence of amino acid residues, in some embodiments, the permeable shell may include a thin metallic film material. The thin film metal may be fabricated by sputter deposition and may be formed in multiple layers. The thin film may be a nickel-titanium alloy also known as nitinol.

[0161] With regard to the above detailed description, like reference numerals used therein refer to like elements that may have the same or similar dimensions, materials and configurations. While particular forms of embodiments have been illustrated and described, it will be apparent that various modifications can be made without departing from the spirit and scope of the embodiments of the invention. Accordingly, it is not intended that the invention be limited by the forgoing detailed description.

What is claimed is:

1. A device for treating an aneurysm comprising:
 - a resilient body made of plural filaments extending between a distal end and a proximal end of the body;
 - the body being deformable to a placement configuration for engaging the body with an aneurysm, the body being materially biased to an enlarged configuration in which the body presents a curvilinear surface to tissue abutting the body;
 - the proximal end being everted to form a concave proximal cavity defining a proximal periphery, a proximal hub assembly being disposed in the proximal cavity, wherein the proximal hub assembly is connectable to a tether and the proximal hub assembly includes a hub cavity for mechanically capturing a knot associated with the tether.
2. The device of claim **1**, wherein the proximal hub assembly defines a proximal end and the proximal end of the proximal hub assembly is recessed distally from the proximal periphery.
3. The device of claim **1**, the filaments including at least plural first filaments interwoven with at least plural second filaments, the first filaments having a first diameter and the second filaments having a second diameter.
4. The device of claim **1**, wherein the proximal hub assembly defines a proximal end and the proximal end of the proximal hub assembly is not recessed distally from the proximal periphery.
5. The device of claim **1**, comprising the tether and a heater coil surrounding a distal portion of the tether to break the tether responsive to energization of the heater coil.
6. The device of claim **5**, wherein the heater coil includes a close-wound electrical conductor and the close-wound electrical conductor is connected to first and second lead conductors configured for electrically energizing the close-wound heater coil, at least the first conductor extending away from the close-wound heater coil in a configuration that is less close-wound than the close-wound heater coil.
7. The device of claim **6**, the second conductor extending away from the close-wound heater coil in a configuration that is less close-wound than the close-wound heater coil.

8. The device of claim **1**, wherein the distal end is everted to form a distal cavity defining a distal periphery, and a distal hub is disposed in the distal cavity, the distal hub being connected to distal ends of at least some of the filaments.

9. The device of claim **1**, the filaments including at least plural first filaments interwoven with at least plural second filaments, the first filaments having a first diameter and the second filaments having a second diameter, the second diameter being different from the first diameter.

10. The device of claim **1**, wherein the proximal hub assembly defines a hub cavity for mechanically capturing a knot associated with the tether, the hub cavity being established by a proximal shoulder portion of the proximal hub assembly, the proximal shoulder portion including an opening through which the tether can extend but through which opening the knot cannot pass.

11. The device of claim **8**, wherein the distal hub defines a distal end and the distal end of the distal hub is recessed proximally from the distal periphery.

12. The device of claim **10**, wherein the knot is secured by bonding to a distal end of the tether within the hub cavity.

13. The device of claim **10**, wherein the knot is secured by bonding to proximal ends of the filaments.

14. A device for treating an aneurysm comprising:

- a resilient body made of plural filaments extending between a distal end and a proximal end of the body;
- the body being deformable to a placement configuration for engaging the body with an aneurysm, the body being materially biased to an enlarged configuration in which the body presents a curvilinear surface to tissue abutting the body;
- a proximal hub assembly disposed proximally on the body, wherein the proximal hub assembly is connected to a tether;
- a heater coil surrounding a distal portion of the tether to break the tether responsive to energization of the heater coil, wherein the heater coil includes a close-wound electrical conductor and the close-wound electrical conductor is connected to first and second lead conductors configured for electrically energizing the close-wound heater coil.

15. The device of claim **14**, wherein the proximal end is everted to form a concave proximal cavity defining a proximal periphery.

16. The device of claim **14**, wherein the proximal hub assembly includes a hub cavity for mechanically capturing a knot associated with the tether.

17. The device of claim **15**, wherein the proximal hub assembly defines a proximal end and the proximal end of the proximal hub assembly is recessed distally from the proximal periphery.

18. The device of claim **14**, the filaments including at least plural first filaments interwoven with at least plural second filaments, the first filaments having a first diameter and the second filaments having a second diameter.

19. The device of claim **15**, wherein the proximal hub assembly defines a proximal end and the proximal end of the proximal hub assembly is not recessed distally from the proximal periphery.

20. The device of claim **14**, comprising a distal hub disposed at the distal end of the body and connected to at least some of the filaments.

21. The device of claim 20, wherein the distal end is everted to form a distal cavity defining a distal periphery, and a distal hub is disposed in the distal cavity.

22. Apparatus comprising:
resilient body composed of filaments with respective proximal and distal ends;
a recessed distal hub securing the distal ends;
a recessed proximal hub assembly securing the proximal ends;
a tether secured to the proximal hub assembly;
an electrically energizable heater coil coiled around a distal segment of the tether to break the tether when the heater coil is energized; and
insulative tubing covering the heater coil.

23. The device of claim 1, wherein the body includes plural first filaments including platinum and plural second filaments made of only nitinol.

24. The device of claim 14, wherein the body includes plural first filaments including platinum and plural second filaments made of only nitinol.

* * * * *