



(19) **United States**
(12) **Patent Application Publication**
HU et al.

(10) **Pub. No.: US 2014/0090411 A1**
(43) **Pub. Date: Apr. 3, 2014**

(54) **HEAT PUMP SYSTEM AND AIR-CONDITIONER**

Publication Classification

(71) Applicants: **GUANGXI UNIVERSITY**, Guangxi (CN); **GUANGXI JUNFUHUANG GROUND SOURCE HEAT PUMP CO., LTD**, Guangxi (CN)

(51) **Int. Cl.** *F25B 30/00* (2006.01)
(52) **U.S. Cl.** CPC *F25B 30/00* (2013.01)
USPC *62/291; 62/467*

(72) Inventors: **Yingning HU**, Guangxi (CN); **Biao LI**, Guangxi (CN); **Jun LIN**, Guangxi (CN); **Chengyong WANG**, Guangxi (CN)

(57) **ABSTRACT**

A heat pump system, including a main heat pump system and a directly expanded strong cool-heat radiation plate provided on the building surface and serving as the terminal of the main heat pump system. The directly expanded strong cool-heat radiation plate enables refrigerant in the main heat pump system to circulate therein. Since the heat pump system of the present application adopts the directly expanded strong cool-heat radiation plate as the terminal of the main heat pump system, refrigerant in the main heat pump system may exchange heat with air by means of the directly expanded strong cool-heat radiation plate directly, instead of secondary heat exchange of the refrigerant loop and the water circulation loop, thereby reducing loss in intermediate heat exchange, improving the heat exchange efficiency and heat utilization, and omitting the circulating pump for water circulation. An air-conditioner with the heat pump system is further disclosed.

(73) Assignees: **GUANGXI UNIVERSITY**, Guangxi (CN); **GUANGXI JUNFUHUANG GROUND SOURCE HEAT PUMP CO., LTD**, Guangxi (CN)

(21) Appl. No.: **14/066,703**

(22) Filed: **Oct. 30, 2013**

(30) **Foreign Application Priority Data**

Aug. 16, 2013 (CN) 201310358748.4

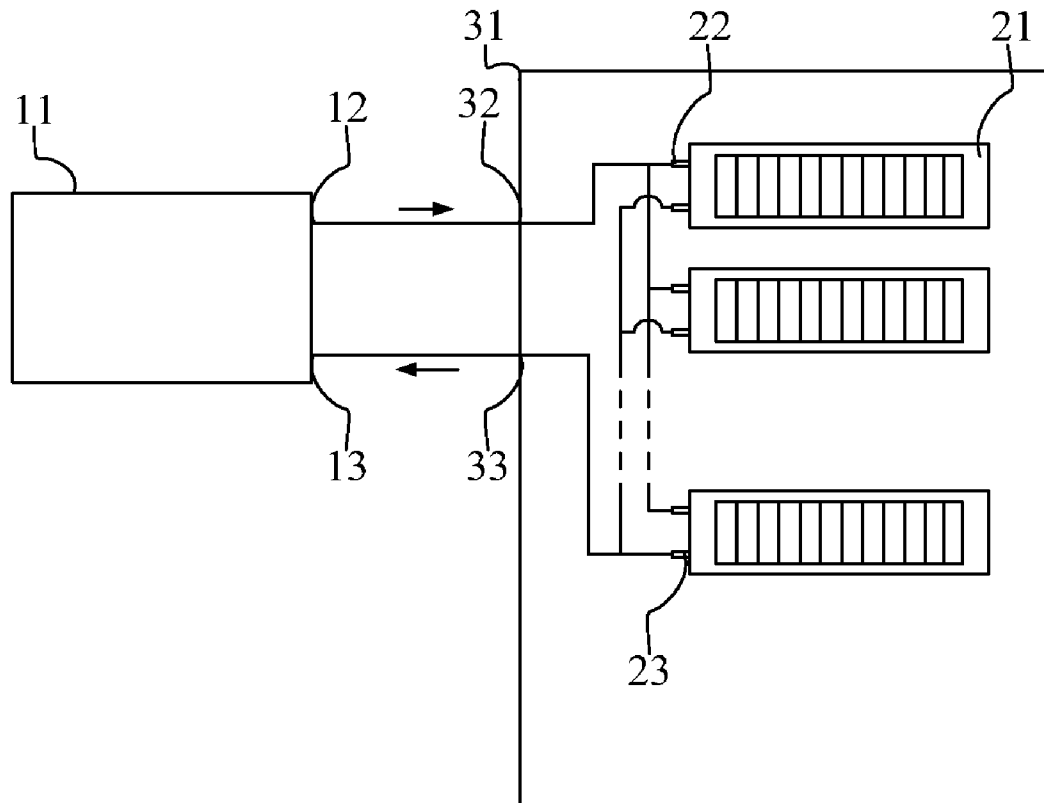

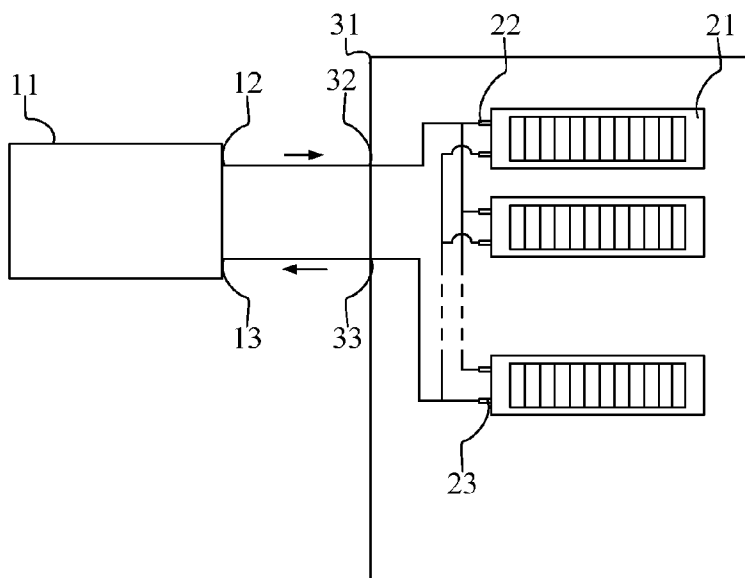

Fig. 1

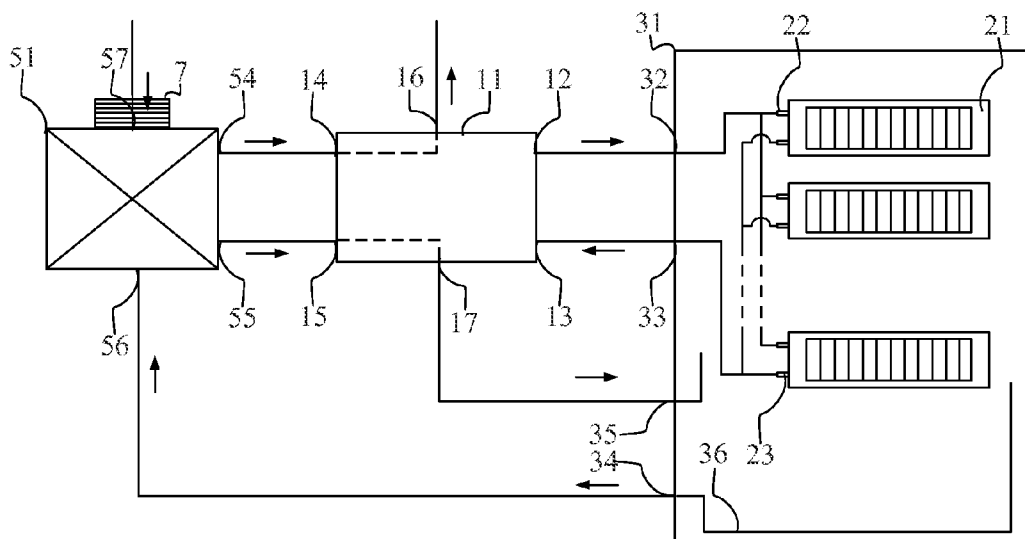

Fig. 2

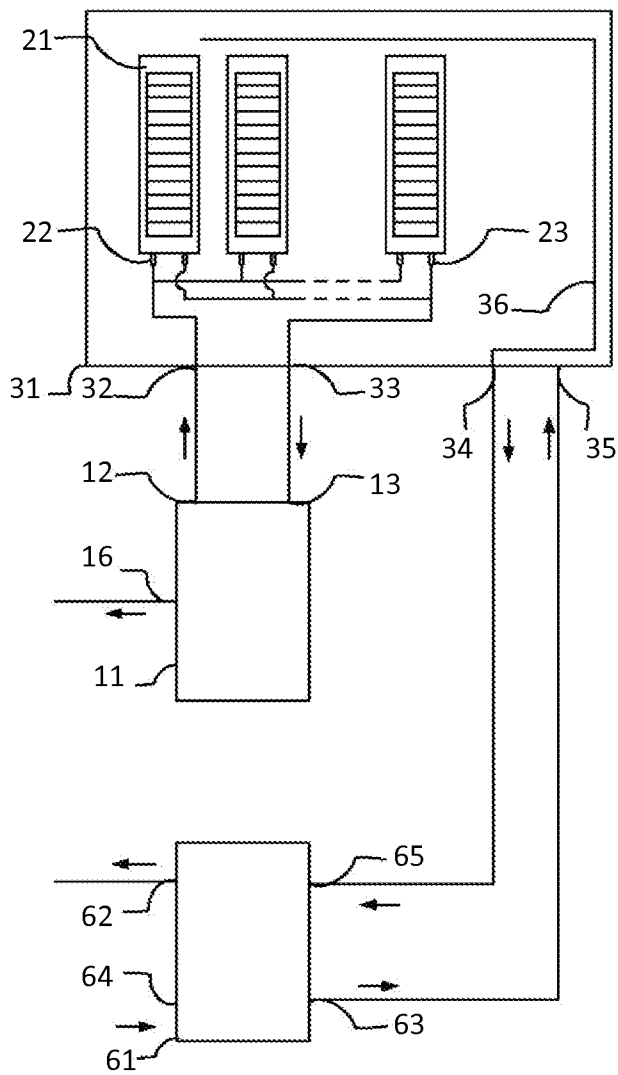

Fig. 3

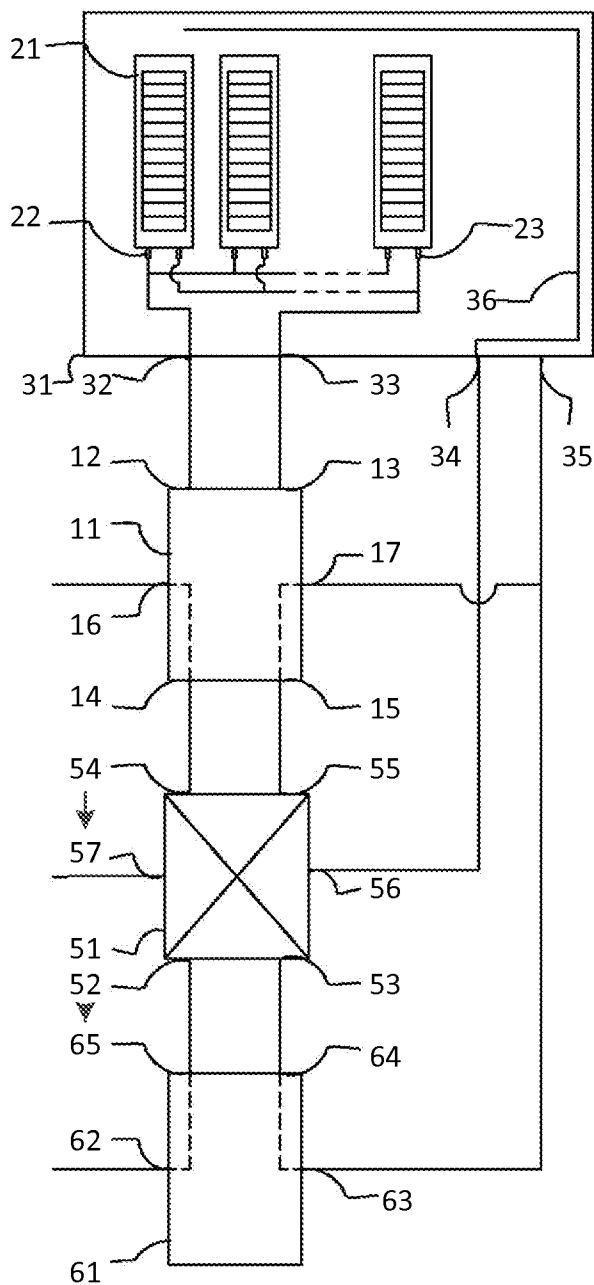

Fig. 4

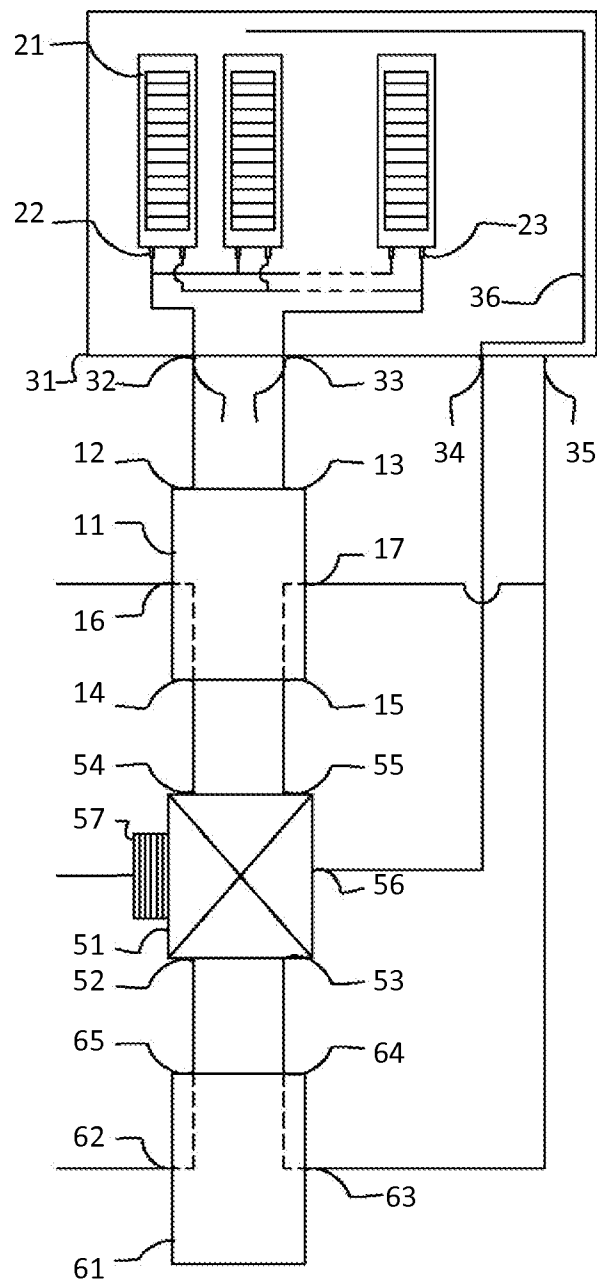

Fig. 5

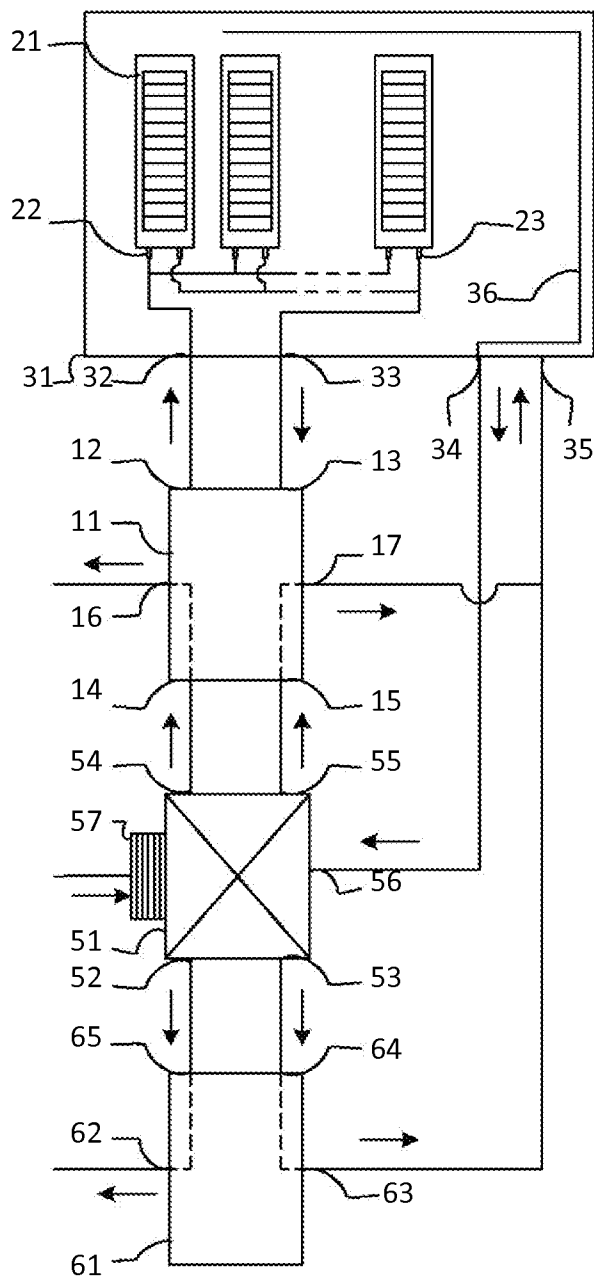

Fig. 6

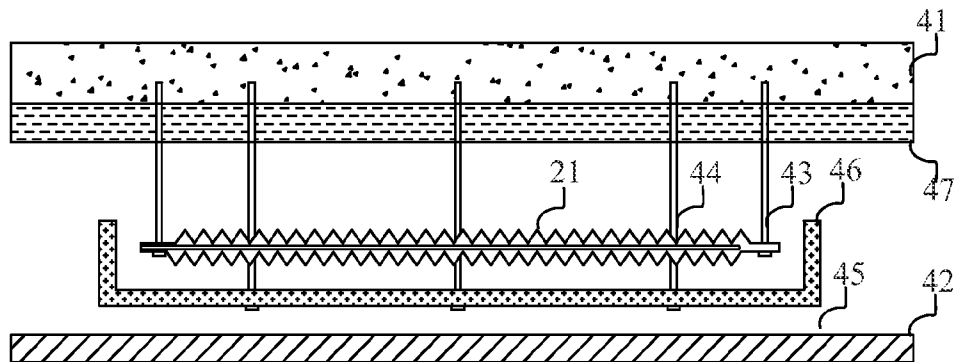

Fig. 7

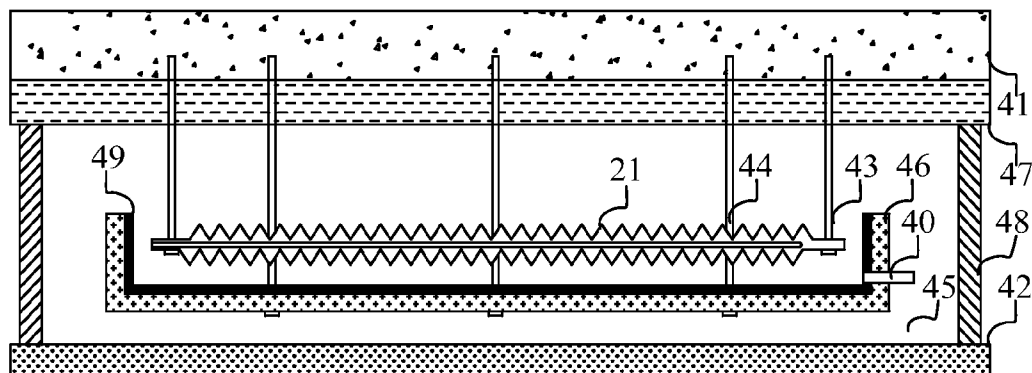

Fig. 8



Fig. 9

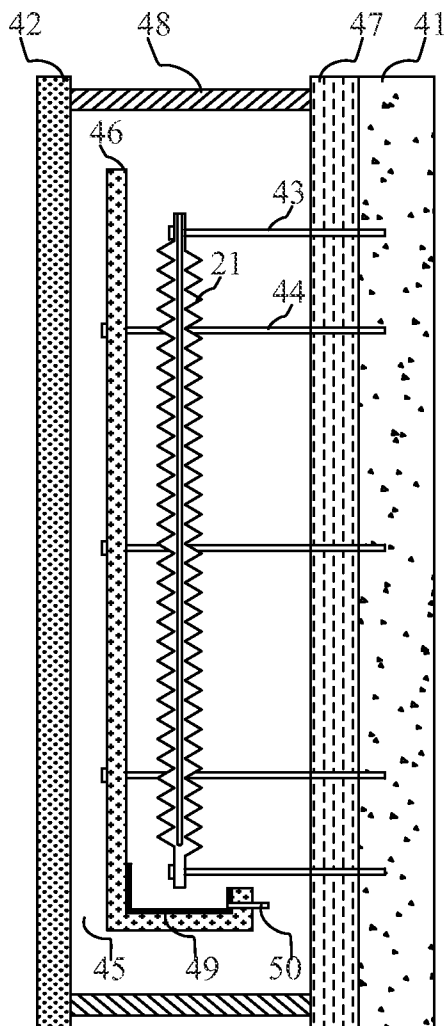

Fig. 10

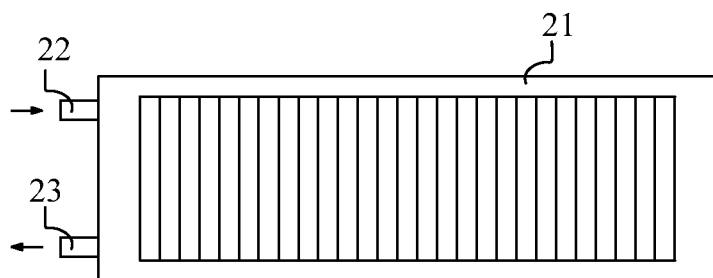

Fig. 11

HEAT PUMP SYSTEM AND AIR-CONDITIONER

[0001] This application claims the benefit of the priority to the Chinese Patent Application No. 201310358748.4 filed with the Chinese Patent Office on Aug. 16, 2013, entitled “HEM RUMP SYSTEM AND AIR-CONDITIONER”, the disclosure of which is incorporated herein by reference.

FIELD OF THE INVENTION

[0002] The present application relates to an air-conditioner, and in particular, to a heat pump system and an air-conditioner.

BACKGROUND OF THE INVENTION

[0003] The air-conditioner generally refers herein to a room air conditioner, and specifically is a set for providing conditioned air into a room (or an enclosed space or area). Most of conventional air-conditioners perform cooling or heating in the room in convective heat-transfer manner. Specifically, a fan coil may serve as the terminal unit of an air-conditioner. A fan is provided in the fan coil in advance. Air in the region of the fan coil is circulated continuously under the action of the fan. The air is cooled or heated after flowing through a refrigerant coil or a hot-water (or chilled-water) coil, thereby cooling or heating the room. Because cooling or heating is achieved in the convective heat-transfer manner, the indoor temperature is not uniform. Either cooling or heating, the indoor temperature difference is generally greater than 10 degrees centigrade, even more than 20 degrees centigrade. Part of the cool or hot airflow is too large, which results in uncomfortableness of a human body, local cold, or even illness.

[0004] In order to solve the above problem, a radiation coil is adopted at the terminal of air-conditioner. The radiation coil is provided therein with chilled water (or hot water), and is arranged on the surface structure of the building (the ceiling surface or the ground surface). The chilled water (or hot water) in the radiation coil cools or heats a particular area in radiating manner. Such a structure of air-conditioner achieves the uniform cooling or heating to a certain extent, however, the water circulation loop of the radiation coil is required to exchange heat with a heat exchanger in a refrigerant loop of an air-conditioner firstly, and then exchange heat with the indoor air, thereby adding an intermediate heat exchange procedure and increasing the energy consumption of a power apparatus for delivering water circulation, for example, a circulating pump. Thus, the efficiency of heat exchange is low, and the installation of the system is complex.

[0005] In conclusion, it is desirable for the person skilled in the art to improve the efficiency of heat exchange.

SUMMARY OF THE INVENTION

[0006] In view of the above fact, there are provided according to the present application a heat pump system and an air-conditioner which may increase the efficiency of heat exchange. In order to achieve the above objects, the following technical solutions are set forth in the present application.

[0007] A heat pump system includes a main heat pump system, and a directly expanded strong cool-heat radiation plate provided on a building surface and serving as the terminal of the main heat pump system. The directly expanded

strong cool-heat radiation plate is configured to allow refrigerant in the main heat pump system to circulate therein.

[0008] Preferably, in the heat pump system, the directly expanded strong cool-heat radiation plate is a single piece.

[0009] Preferably in the heat pump system, the directly expanded strong cool-heat radiation plate includes multiple pieces, and the multiple pieces of the directly expanded strong cool-heat radiation plate are interconnected in series or in parallel.

[0010] Preferably, in the heat pump system, a heat retaining layer and a reflecting layer are provided on the building surface, and the reflecting layer is provided on an outside surface of the heat retaining layer facing indoors, and the directly expanded strong cool-heat radiation plate is fixed on the building surface by means of a bracket.

[0011] Preferably, in the heat pump system, a decorative face is provided on a side of the directly expanded strong cool-heat radiation plate exposed to the outside, and a packed layer with an enclosed cavity structure is located between the decorative face and the directly expanded strong cool-heat radiation plate.

[0012] Preferably, in the heat pump system, a buffer plate is further provided between the packed layer and the directly expanded strong cool-heat radiation plate.

[0013] Preferably, in the heat pump system, a protective condensation trough for receiving condensed water is provided below the directly expanded strong cool-heat radiation plate, and is provided therein with a condensate outlet.

[0014] The heat pump system according to the embodiment of the present application, includes a main heat pump system; and a directly expanded strong cool-heat radiation plate provided on a building surface and serving as the terminal of the main heat pump system. The directly expanded strong cool-heat radiation plate is configured to allow refrigerant in the main heat pump system to circulate therein. Compared with the air-conditioner in the prior art, since the heat pump system of the present application adopts the directly expanded strong cool-heat radiation plate as the terminal of the main heat pump system, refrigerant in the main heat pump system may exchange heat with air by means of the directly expanded strong cool-heat radiation plate directly, instead of secondary heat exchange of the refrigerant loop and the water circulation loop, thereby reducing loss in intermediate heat exchange, improving the heat exchange efficiency and heat utilization, and omitting the circulating pump for water circulation so as to lower energy consumption and simplify the installation.

[0015] The present application further discloses an air-conditioner, including a chassis, and the heat pump system according to any one of the above technical solutions. The main heat pump system of the heat pump system is provided in the chassis.

[0016] Preferably, the air-conditioner further includes a replacement air heat pump system provided in the chassis, and a replacement air outlet of the replacement air heat pump system is adapted to be connected to an indoor replacement air intake

[0017] Preferably, in the air-conditioner, an air heat exchanger is provided between the main heat pump system and the replacement air heat pump system, wherein a first replacement air outlet of the air heat exchanger is connected to a replacement air intake of the replacement air heat pump system, a first return eduction air outlet of the air heat exchanger is connected to a heat source side air intake of the replacement air heat pump system, a second replacement air

outlet of the air heat exchanger is connected to a replacement air intake of the main heat pump system, a second return eduction air outlet of the air heat exchanger is connected to a heat source side air intake of the main heat pump system, a return air intake of the air heat exchanger is connected to a return eduction outlet of the room.

[0018] Preferably, in the air-conditioner a multistage air filter is provided at a replacement air intake of the air heat exchanger.

[0019] Preferably, the air-conditioner, the return air intake of the air heat exchanger is also connected to a return air pipe arranged in the room.

[0020] A secondary heat exchange of the refrigerant loop and the water circulation loop is needless, thereby reducing loss in intermediate heat exchange, improving the heat exchange efficiency and heat utilization, and omitting the circulating pump for water circulation so as to lower energy consumption and simplify the installation. In the event that the heat pump system has the above technical effects, the air-conditioner with the heat pump system also has the corresponding technical effects.

BRIEF DESCRIPTION OF THE DRAWINGS

[0021] To illustrate embodiments of the present application or the technical solution in the prior art more clearly, drawings used in description of the embodiments or the prior art will be described briefly below. Obviously, the drawings described below are only directed to some of the embodiments of the application, and the person skilled in the art may achieve other drawings according to such drawings without creative efforts.

[0022] FIG. 1 is a schematic view of a heat pump system according to an embodiment of present application;

[0023] FIGS. 2 to 6 are schematic views of an air-conditioner according to embodiments of the present application;

[0024] FIGS. 7 to 10 are schematic views showing the installation of a directly expanded strong cool-heat radiation plate according to embodiments of the present application; and

[0025] FIG. 11 is a schematic structural view of a directly expanded strong cool-heat radiation plate according to an embodiment of the present application.

[0026] Reference numerals in FIGS. 1 to 11:

| | |
|--|--------------------------------------|
| 11. main heat pump system | 12. working medium outlet |
| 13. working medium return intake | 14. heat source side air intake |
| 15. replacement air intake | 16. eduction air outlet |
| 17. replacement air outlet | |
| 21. directly expanded strong cool-heat radiation plate | |
| 22. working medium inlet | 23. working medium outlet |
| 31. room | 32. installation port |
| 33. installation port | 34. return air outlet |
| 35. replacement air intake | 36. return air pipe |
| 40. condensate outlet | 41. building surface |
| 42. decorative face | 43. bracket |
| 44. bracket | 45. packed layer |
| 46. buffer plate | 47. heat retaining layer |
| 48. supporter | 49. protective condensation rough |
| 51. air heat exchanger | 52. first return air outlet |
| 53. first replacement air outlet | 54. second return air outlet |
| 55. second replacement air outlet | 56. return air intake |
| 57. replacement, air intake | 61. replacement air heat pump system |
| 62. eduction air outlet | 63. replacement air outlet |
| 64. replacement air intake | 65. heat source side air intake |
| 7. multistage air filter | |

DETAILED DESCRIPTION

[0027] Hereinafter, the embodiments will be described in conjunction with the drawings. Furthermore, the embodiments illustrated below have no any limitation to inventive contents recited in claims, and are not necessary in its entirety for solutions of inventions defined in the claims. p There are provided in the present application a heat pump system and an air-conditioner which may reduce energy consumption of the air conditioner.

[0028] Referring to FIG. 1, it is a schematic view of a heat pump system according to an embodiment of the present application.

[0029] The heat pump system includes a main heat pump system 11, and a directly expanded strong cool-heat radiation plate 21 provided on the surface of the building and serving as the terminal of the main heat pump system 11. The interior of the directly expanded strong cool-heat radiation plate 21 enables the circulation of refrigerant in the main heat pump system 11.

[0030] Compared with the air-conditioner in the prior art, since the heat pump system of the present application adopts the directly expanded strong cool-heat radiation plate 21 as the terminal of the main heat pump system 11, refrigerant in the main heat pump system 11 may exchange heat with air by means of the directly expanded strong cool-heat radiation plate 21 directly, instead of secondary heat exchange of the refrigerant loop and the water circulation loop, thereby reducing loss in intermediate heat exchange, improving the heat exchange efficiency and heat utilization, and omitting the circulating pump for water circulation so as to lower energy consumption and simplify the installation.

[0031] For the purpose of saving energy further, as shown in FIG. 2, an air heat exchanger 51 is provided on the main heat pump system 11. Specifically, a return air intake 56 of the air heat exchanger 51 communicates with a return air outlet 3'4 of a room 31; a second return air outlet 54 of the air heat exchanger 51 is connected to a heat source side air intake 14 of the main heat pump system 11; a second replacement air outlet 55 of the air heat exchanger 51 communicates with a replacement air intake 15 of the main heat pump system 11; and a replacement air outlet 17 of the main heat pump system 11 communicates with a replacement air intake 35 of the room 31.

[0032] A multistage air filter 7 is further provided at a replacement air intake 57 of the air heat exchanger 51 in order to purify air.

[0033] When the main heat pump system 11 is running, the working medium in the main heat pump system 11 flows through a working medium feeding pipe into the directly expanded strong cool-heat radiation plate 21 arranged in the room 31. The working medium is evaporated as a result of absorbing heat front the room 31 so as to radiate cooling quantity (or condensed as a result of releasing heat into the room 31 so as to radiate heating quantity), and then returns to the main heat pump system 11 through a working medium discharging pipe. At the same time, outdoor fresh air flows into the air heat exchanger 51 via the multistage air filter 7, and makes primary heat exchange with the return air from the room 31 so as to obtain primary pre-cooled and filtered replacement air (or pre-heated and filtered replacement air). Then, the primary pre-cooled and filtered replacement air flows into the main heat pump system 11 to be secondarily pre-cooled and dehumidified (or preheated and humidified) so as to form the replacement air which will be supplied into

the room 31. Return air undergoing primary heat recovery flows through a heat source side air intake 14 into the main heat pump system 11, and return air undergoing secondary full heat recovery is discharged from an education air outlet 16 of the main heat pump system 11.

[0034] In order to improve the comfortable feeling in the room, a return air intake 56 of the air heat exchanger 51 is also connected to a return air pipe 36 disposed in the room 31. The return air pipe 36 passes through a return air outlet 34 of the room 31. The provision of the return air pipe 36 may avoid the replacement air from short circuit, and improve indoor air quality.

[0035] Referring to FIGS. 7 to 11, FIGS. 7 to 10 are schematic views showing the installation of a directly expanded strong cool-heat radiation plate 21 according to embodiments of the present application; and FIG. 11 is a schematic structural view of a directly expanded strong cool-heat radiation plate 21 according to an embodiment of the present application.

[0036] In order to reduce the loss of cool or heat quantity, a heat retaining layer 47 is provided on a building surface 41. The directly expanded strong cool-heat radiation plate 21 is fixed to the building surface 41 by means of a bracket 43. In order to reduce the dissipation of cool or heat quantity, a reflecting layer is provided on the outside surface of the heat retaining layer 47 which faces towards the interior of the room 31. The provision of the reflecting layer may transfer cool quantity (or heat quantity) radiated from the directly expanded strong cool-heat radiation plate 21 to the room 31 more efficiently. When the directly expanded strong cool-heat radiation plate 21 is provided on a different building surface 41, the bracket 43 may be varied. For example, when the building surface 41 is a ceiling surface, as shown in FIGS. 7 and 8, the bracket 43 may be of a flexible construction or a rigid construction; when the building surface 41 is a ground surface, as shown in FIG. 9, in order to ensure an appropriate space for installing a buffer plate 46 with respect to the directly expanded strong cool-heat radiation plate 21, and to ensure the thickness of a packed layer 45 and a firm supported decorative face 42, the bracket 43 is preferably of a rigid construction; and when the building surface 41 is a vertical surface, as shown in FIG. 10, similarly, in order to ensure an appropriate space for installing a buffer plate 46 with respect to the directly expanded strong cool-heat radiation plate 21, and to ensure the thickness of a packed layer 45 and a firm supported decorative face 42, the bracket 43 is preferably of a rigid construction.

[0037] To ensure the aesthetic appearance of the room 31 after the directly expanded strong cool-heat radiation plate 21 is mounted, the decorative face 42 is provided on the side of the directly expanded strong cool-heat radiation plate 21 which is exposed to the outside, and the packed layer 45 with closed cavity structure is located between the decorative face 42 and the directly expanded strong cool-heat radiation plate 21. The decorative face 42 has different name depending on the different building surface 41. When the building surface 41 is a ceiling surface, the decorative face 42 is the ceiling or any face with ornamental effect. When the building surface 41 is a ground surface, the decorative face 42 is a floor, and specifically, the floor could be lithoid floor, tile floor, metal floor, or wooden floor, etc. When the building surface 41 is a vertical surface, the decorative face 42 is a false wall layer with ornamental effect.

[0038] The packed layer 45 has a cavity structure with an enclosed space defined by the decorative face 42, the directly expanded strong cool-heat radiation plate 21 and peripheral structures. Since the packed layer 45 is located between the decorative face 42 and the directly expanded strong cool-heat radiation plate 21, it is possible to relieve the occurrence of moisture condensation because of local overcooling or the occurrence of overheating of the directly expanded strong cool-heat radiation plate 21 effectively in the cold or heat radiating process. The temperature of the decorative face 42 is more uniform. The comfortable feeling in the room 31 is thus improved.

[0039] In order to further relieve the occurrence of moisture condensation because of local overcooling or the occurrence of overheating, the buffer plate 46 is located between the packed layer 45 and the directly expanded strong cool-heat radiation plate 21. The buffer plate 46 is fixed to the building surface 41 by means of a bracket 44. The provision of the buffer plate 46 could weaken the transfer effect of cool or heat quantity from the directly expanded strong cool-heat radiation plate 21 to the room 31. When the main heat pump system performs refrigerating for heating, the directly expanded strong cool-heat radiation plate 21 achieves secondary heat radiation under the combined effect of the buffer plate 46 and the packed layer 45, so that the temperature of the decorative face 42 further tends to be uniform. The comfortable feeling in the room 31 is thus improved further.

[0040] In a further technical solution, in order to prevent damage to inner parts because of moisture condensation in enclosed space of assembly of the directly expanded strong cool-heat radiation plate 21, a protective condensation trough 49 for receiving condensed water is provided below the directly expanded strong cool-heat radiation plate 21, and is provided therein with a condensate outlet 40. When the moisture condensation of the directly expanded strong cool-heat radiation plate 21 occurs, it will be collected in the protective condensation trough 49, and drains via the condensate outlet 40 through a preset pipeline. As shown in FIG. 8, when the building surface 41 is a ceiling surface, the protective condensation trough 49 is provided on the buffer plate 46 entirely; as shown in FIG. 9, when the building surface 41 is a ground surface, the protective condensation trough 49 is provided on the heat retaining layer 47 entirely; and as shown in FIG. 10, when the building surface 41 is a vertical surface, the protective condensation trough 49 is provided at the lower portion of the buffer plate 46.

[0041] Since heat exchange efficiency of the heat pump system with the above structure is higher and the energy consumption is lower, when the directly expanded strong cool-heat radiation plate 21 of the heat pump system is mounted on the building surface 41, construction and layout may be performed on a small area of the building surface 41, rather than the whole building surface 41. In order to achieve the sufficient strength, a supporter 48 adapted for supporting the decorative face 42 is provided between the decorative face 42 and the building surface 41. Specifically, the supporters 48 may be arranged around the directly expanded strong cool-heat radiation plate 21, so as to separate the building surface 41 with the directly expanded strong cool-heat radiation plate 21 thereon from the building surface 41 without the directly expanded strong cool-heat radiation plate 21 thereon.

[0042] As shown in FIG. 11, the directly expanded strong cool-heat radiation plate 21 may include various effective heat transfer structures in which a refrigerant pipeline (copper

pipe, aluminum pipe, etc.) and a fixed pipeline may be formed with the radiating surfaces. The radiating surfaces may be a metal plate or a surface cooler, etc. The directly expanded strong cool-heat radiation plate 21 may also be of a plate structure with various refrigerant cavity which may transfer heat effectively. The refrigerant in the main heat pump system 11 may be circulated in the plate, and a working medium inlet 22, and a working medium outlet 23 are provided in the directly expanded strong cool-heat radiation plate 21. The directly expanded strong cool-heat radiation plate 21 may be a single piece or multiple pieces. In case of multiple pieces, a plurality of the directly expanded strong cool-heat radiation plate 21 are interconnected in series or in parallel.

[0043] Because the directly expanded strong cool-heat radiation plate 21 in the air-conditioner disclosed in the embodiments of the application exchanges heat with the room 31 directly, the intensity of the cooling and heating radiation is large, and the directly expanded strong cool-heat radiation plate 21 is mounted on a reduced area with ease. It is possible to ensure the cooling and heating quantity needed for comfortable feeling in the room 31, reduce the area of the room 31 for radiation, and have no effect on the use of space of the room 31.

[0044] An air-conditioner is further disclosed in an embodiment of the present application. As shown in FIGS. 1 to 6, the air-conditioner includes a chassis (not marked in the figures), and the main heat pump system 11 of the heat pump system in the above any solution is provided in the chassis. The working medium outlet 12 of the main heat pump system 11 communicates with the working medium inlet 22 of the directly expanded strong cool-heat radiation plate 21 via a working medium feeding pipe, and the working medium feeding pipe extends through an installation port 32 of the room 31. A working medium return intake 13 of the main heat pump system 11 communicates with the working medium outlet 23 of the directly expanded strong cool-heat radiation plate 21 via a working medium return pipe, and the working medium return pipe extends through the installation port 33 of the room 31. The installation port 32 and the installation port 33 may be the same installation port.

[0045] Because the directly expanded strong cool-heat radiation plate 21 and the main heat pump system 11 are combined in the air-conditioner with the above heat pump system, the refrigerant in the main heat pump system 11 exchanges heat via, the directly expanded strong cool-heat radiation plate 21 directly, instead of secondary heat exchange of the refrigerant loop and the water circulation loop, thereby reducing loss in intermediate heat exchange, improving the heat exchange efficiency and heat utilization, and omitting the circulating pump for water circulation so as to lower energy consumption and simplify the installation.

[0046] The main heat pump system may undertake both sensible heat load (radiation heat transfer) and latent heat load (replacement air pre-cooled dehumidification or preheated humidification) in the room 31. In order to further ensure the quality of the air and comfort in the room 31, as shown in FIG. 3, a replacement air heat pump system 61 is provided in the chassis of the air-conditioner. A replacement air outlet 63 of the replacement air heat pump system 61 is adapted to be connected to the replacement air intake 35 of the room 31. If the room 31 is kept in a good temperature condition, or the sensible heat load is low, the main heat pump system 11 may be intermittently operated generally. In this case, when the main heat pump system 11 is stopped, the replacement air

heat pump system 61 in the embodiment of the present application may filter pre-cooled dehumidified replacement air or may preheat (humidify) the replacement air such as to meet the desired humidity and quality.

[0047] In order to reduce the energy consumption, as shown in FIG. 4, the air heat exchanger 51 is arranged between the main heat pump system 11 and the replacement air heat pump system 61. A first replacement air outlet 53 of the air heat exchanger 51 is connected to a replacement air intake 64 of the replacement air heat pump system 61; a first return eduction air outlet 52 of the air heat exchanger 51 is connected to a heat source side air intake 65 of the replacement air heat pump system 61; the second replacement air outlet 55 of the air heat exchanger 51 is connected to the replacement air intake 15 of the main heat pump system 11; the second return eduction air outlet 54 of the air heat exchanger 51 is connected to the heat source side air intake 14 of the main heat pump system 11; the return air intake 56 of the air heat exchanger 51 is connected to the return eduction air outlet 34 of the room 31; and the replacement air outlet 63 of the replacement air heat pump system 61 communicates with the replacement air intake 35 of the room 31. As shown in FIGS. 5 to 6 in conjunction with FIG. 4, a multistage air filter 7 is provided at a replacement air intake 57 of the air heat exchanger 51 in order to improve the quality of the replacement air flowing into the room 31.

[0048] As shown in FIG. 6, when the replacement air heat pump system 61 and the main heat pump system 11 are both running, working medium in the main heat pump system 11 flows through a working medium feeding pipe into the directly expanded strong cool-heat radiation plate 21 in the room 31. The working medium is evaporated as a result of absorbing heat from the room 31 so as to radiate cooling quantity (or condensed as a result of releasing heat into the room 31 so as to radiate heating quantity), and then returns to the main heat pump system 11 through a working medium discharging pipe. At the same time, outdoor fresh air flows into the air heat exchanger 51 via the multistage air filter 7, and makes primary heat exchange with the return air from the room 31 so as to obtain primary pre-cooled (or pre-heated) and filtered replacement air, apart of which flows into the replacement air heat pump system 61, and the other part of which flows into the main heat pump system 11 to be secondarily pre-cooled and dehumidified (or preheated and humidified) so as to form the replacement air which will be supplied into the room 31. A part of return air undergoing primary heat recovery flows into a heat source side air intake 65 of the replacement air heat pump system 61, and the other part of the return air flows through a heat source side air intake 14 into the main heat pump system 11, and is discharged from the eduction air outlet 16 of the main heat pump system 11 and the eduction air outlet 62 of the replacement air heat pump system 61 after secondary full heat recovery is performed.

[0049] For the above air-conditioner, only the directly expanded strong cool-heat radiation plate 21, the replacement air intake 35, the return eduction air outlet 34, and the return air pipe 36 need to be arranged in the room 31. The temperature in the room 31 is uniform, without the blown feeling and the noise of the apparatus. In addition, with the replacement air heat pump system 61, the conditioned air in the room 31 is fresh, has stable humidity and clean environment, thereby greatly improving the comfort in the room. Also, such a facility is easy to be installed, and may achieve a strong cooling radiation with a large temperature difference without

moisture condensation, nor a strong heating radiation with a large temperature difference without dry and hot feeling and may have a power of the facility reducing more than fifty percent than the conventional air-condition. The use of the air heat exchanger 51 enables an efficient full cool-heat recovery in the replacement air system, a simple structure, small volume, and a low cost.

[0050] The above description of the disclosed embodiments enables the person skilled in the art to practice and use the application. Various modifications to these embodiments may be obvious to the person skilled in the art. The general principle defined therein may be implemented in other embodiments without departing from the spirit and scope of the application. Thus, the application is not limited to these embodiments illustrated herein, but conforms to a broadest scope consistent with the principle and novel features disclosed herein.

- 1. A heat pump system, comprising:
a main heat pump system; and
a directly expanded strong cool-heat radiation plate provided on a building surface and serving as the terminal of the main heat pump system;
wherein the directly expanded strong cool-heat radiation plate is configured to allow refrigerant in the main heat pump system to circulate therein.
- 2. The heat pump system according to claim 1, wherein the directly expanded strong cool-heat radiation plate is a single piece.
- 3. The heat pump system according to claim 2, wherein a heat retaining layer and a reflecting layer are provided on the building surface, and wherein the reflecting layer is provided on an outside surface of the heat retaining layer facing indoors, and the directly expanded strong cool-heat radiation plate is fixed on the building surface by means of a bracket.
- 4. The heat pump system according to claim 3, wherein a decorative face is provided on a side of the directly expanded strong cool-heat radiation plate exposed to the outside, a packed layer with an enclosed cavity structure is located between the decorative face and the directly expanded strong cool-heat radiation plate.
- 5. The heat pump system according to claim 4, wherein a buffer plate is further provided between the packed layer and the directly expanded strong cool-heat radiation plate.
- 6. The heat pump system according to claim 5, wherein a protective condensation trough for receiving condensed water is provided below the directly expanded strong cool-heat radiation plate, and is provided therein with a condensate outlet.
- 7. The heat pump system according to claim 1, wherein the directly expanded strong cool-heat radiation plate comprises multiple pieces, the multiple pieces of the directly expanded strong cool-heat radiation plate are interconnected in series or in parallel.
- 8. The heat pump system according to claim 7, wherein a heat retaining layer and a reflecting layer are provided on the

building surface, and wherein the reflecting layer is provided on an outside surface of the heat retaining layer facing indoors, and the directly expanded strong cool-heat radiation plate is fixed on the building surface by means of a bracket.

9. The heat pump system according to claim 8, wherein a decorative face is provided on a side of the directly expanded strong cool-heat radiation plate exposed to the outside, a packed layer with an enclosed cavity structure is located between the decorative face and the directly expanded strong cool-heat radiation plate.

10. The heat pump system according to claim 9, wherein a buffer plate is further provided between the packed layer and the directly expanded strong cool-heat radiation plate.

11. The heat pump system according to claim 10, wherein a protective condensation trough for receiving condensed water is provided below the directly expanded strong cool-heat radiation plate, and is provided therein with a condensate outlet.

- 12. An air-conditioner, comprising:
a chassis, and
the heat pump system according to claim 1;
wherein the main heat pump system of the heat pump system is provided in the chassis.

- 13. The air-conditioner according to claim 12, further comprising:
a replacement air heat pump system provided in the chassis, wherein a replacement air outlet of the replacement air heat pump system is adapted to be connected to a replacement air intake of a room.

- 14. The air-conditioner according to claim 13, wherein an air heat exchanger is provided between the main heat pump system and the replacement air heat pump system, and wherein a first replacement air outlet of the air heat exchanger is connected to a replacement air intake of the replacement air heat pump system, a first return eduction air outlet of the air heat exchanger is connected to a heat source side air intake of the replacement air heat pump system, a second replacement air outlet of the air heat exchanger is connected to a replacement air intake of the main heat pump system, a second return eduction air outlet of the air heat exchanger is connected to a heat source side air intake of the main heat pump system, a return air intake of the air heat exchanger is connected to a return eduction air outlet of the room.

- 15. The air-conditioner according to claim 14, wherein a multistage air filter is provided at a replacement air intake of the air heat exchanger.

- 16. The air-conditioner according to claim 15, wherein the return air intake of the air heat exchanger is also connected to a return air pipe arranged in the room.

* * * * *