



(51) International Patent Classification:

B65D 5/02 (2006.01) B65D 5/50 (2006.01)
B65D 5/42 (2006.01) B65D 5/72 (2006.01)

(21) International Application Number:

PCT/US2020/027580

(22) International Filing Date:

10 April 2020 (10.04.2020)

(25) Filing Language:

English

(26) Publication Language:

English

(30) Priority Data:

62/837,337 23 April 2019 (23.04.2019) US

(71) Applicant: **GRAPHIC PACKAGING INTERNATIONAL, LLC** [US/US]; Law Department - 9th Floor, 1500 Riveredge Parkway, Suite 100, Atlanta, GA 30328 (US).

(72) Inventors: **KEARNS, Matthew, R.**; 1528 Towne Harbor Lane, Woodstock, GA 30189 (US). **OLIVEIRA, Steven, M.**; 335 Westminster Drive, Canton, GA 30114 (US).

(74) Agent: **CLAERBOUT, Andrew, N.**; Womble Bond Dickinson (us) Llp, P.o. Box 7037, Atlanta, GA 30357-0037 (US).

(81) Designated States (unless otherwise indicated, for every kind of national protection available):

AE, AG, AL, AM, AO, AT, AU, AZ, BA, BB, BG, BH, BN, BR, BW, BY, BZ, CA, CH, CL, CN, CO, CR, CU, CZ, DE, DJ, DK, DM, DO, DZ, EC, EE, EG, ES, FI, GB, GD, GE, GH, GM, GT, HN, HR, HU, ID, IL, IN, IR, IS, JO, JP, KE, KG, KH, KN, KP, KR, KW, KZ, LA, LC, LK, LR, LS, LU, LY, MA, MD, ME, MG, MK, MN, MW, MX, MY, MZ, NA, NG, NI, NO, NZ, OM, PA, PE, PG, PH, PL, PT, QA, RO, RS, RU, RW, SA, SC, SD, SE, SG, SK, SL, ST, SV, SY, TH, TJ, TM, TN, TR, TT, TZ, UA, UG, US, UZ, VC, VN, WS, ZA, ZM, ZW.

(84) Designated States (unless otherwise indicated, for every kind of regional protection available):

ARIPO (BW, GH, GM, KE, LR, LS, MW, MZ, NA, RW, SD, SL, ST, SZ, TZ, UG, ZM, ZW), Eurasian (AM, AZ, BY, KG, KZ, RU, TJ, TM), European (AL, AT, BE, BG, CH, CY, CZ, DE, DK, EE, ES, FI, FR, GB, GR, HR, HU, IE, IS, IT, LT, LU, LV, MC, MK, MT, NL, NO, PL, PT, RO, RS, SE, SI, SK, SM, TR), OAPI (BF, BJ, CF, CG, CI, CM, GA, GN, GQ, GW, KM, ML, MR, NE, SN, TD, TG).

(54) Title: CARTON FOR AN ARTICLE

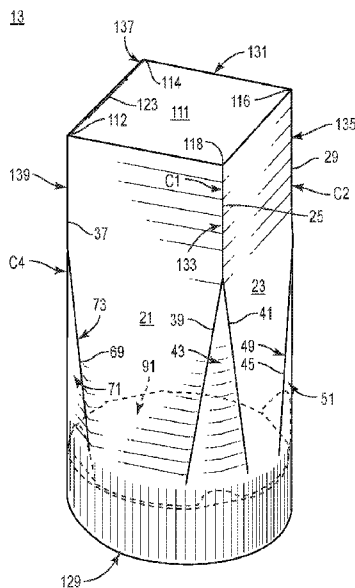

FIG. 5

(57) Abstract: A carton for holding at least one article includes a plurality of panels extending at least partially around an interior of the carton, the plurality of panels comprising a front panel, a back panel, and at least one side panel, at least one top end flap foldably connected to a panel of the plurality of panels, and at least one bottom end flap foldably connected to a panel of the plurality of panels. The at least one bottom end flap is for forming a closed bottom of the carton and the at least one top end flap is for forming a closed top of the carton. The closed top of the carton has a square configuration and the closed bottom has a round configuration.



Declarations under Rule 4.17:

- *as to applicant's entitlement to apply for and be granted a patent (Rule 4.17(ii))*
- *as to the applicant's entitlement to claim the priority of the earlier application (Rule 4.17(iii))*

Published:

- *with international search report (Art. 21(3))*

CARTON FOR AN ARTICLE**CROSS-REFERENCE TO RELATED APPLICATIONS**

[0001] This application claims the benefit of each of U.S. Provisional Patent Application No. 62/837,337, filed on April 23, 2019.

INCORPORATION BY REFERENCE

[0002] The disclosures of each of U.S. Provisional Patent Application No. 62/837,337, filed on April 23, 2019, and U.S. Design Patent Application No. 29/689,508, filed on April 30, 2019, are hereby incorporated by reference for all purposes as if presented herein in their entirety.

BACKGROUND OF THE DISCLOSURE

[0003] The present disclosure generally relates to cartons for holding and dispensing products or articles such as hardware products, household products (e.g., charcoal briquettes, etc.) or automotive products, e.g., oil filters, air filters, etc.

SUMMARY OF THE DISCLOSURE

[0004] According to one aspect of the disclosure, a carton for holding at least one article comprises a plurality of panels extending at least partially around an interior of the carton, the plurality of panels comprising a front panel, a back panel, and at least one side panel. The carton further comprises at least one top end flap foldably connected to a panel of the plurality of panels, the at least one top end flap is for forming a closed top of the carton, and at least one bottom end flap foldably connected to a panel of the plurality of panels, the at least one bottom end flap is for forming a closed bottom of the carton. The closed top of the carton has a square configuration and the closed bottom has a round configuration.

[0005] According to another aspect of the disclosure, a blank for forming a carton for holding at least one article comprises a plurality of panels for extending at least partially around an interior of the carton formed from the blank, the plurality of panels comprising a front panel, a back panel, and at least one side panel. The blank further comprises at least one top end flap foldably connected to a panel of the plurality of panels, the at least one top end flap is for forming a closed top of the carton formed from the blank, and at least one bottom end flap foldably connected to a panel of the plurality of panels, the at least one second end flap is for forming a closed bottom of the carton formed from the blank such that the closed top of the carton formed from the blank has a square configuration and the closed bottom formed from the blank has a round configuration.

[0006] According to another aspect of the disclosure, a method of forming a carton for holding at least one article includes obtaining a blank comprising a plurality of panels comprising a front panel, a back panel, and at least one side panel, the blank further comprising at least one top end flap foldably connected to a panel of the plurality of panels, and at least one bottom end flap foldably connected to a panel of the plurality of panels. The method further comprises folding the plurality of panels at least partially around an interior of the carton, folding the at least one top end flap to form a closed top of the carton, and folding the at least one bottom end flap to form a closed bottom of the carton such that the closed top of the carton has a square configuration and the closed bottom has a round configuration.

[0007] Other aspects, features, and details of the present disclosure can be more completely understood by reference to the following detailed description of exemplary embodiments taken in conjunction with the drawings and from the appended claims.

[0008] Those skilled in the art will appreciate the above-stated advantages and other advantages and benefits of various additional embodiments reading the following detailed description of the embodiments with reference to the below-listed drawing figures.

BRIEF DESCRIPTION OF THE DRAWINGS

[0009] According to common practice, the various features of the drawings discussed below are not necessarily drawn to scale. Dimensions of various features and elements in the drawings may be expanded or reduced to more clearly illustrate the embodiments of the disclosure.

[0010] Fig. 1 is a plan view of an exterior surface of a blank for forming a carton according to a first exemplary embodiment of the disclosure.

[0011] Fig. 2 is a plan view of an interior surface of the blank of Fig. 1.

[0012] Fig. 3 is a plan view of the blank of Fig. 1 in a partially folded configuration.

[0013] Fig. 4 is a perspective view of a formation of a carton from the blank of Fig. 1.

[0014] Fig. 5 is a perspective view of a carton formed from the blank of Fig. 1.

[0015] Fig. 6 is another perspective view of the carton of Fig. 5.

[0016] Fig. 7 is a plan view of a blank for forming a carton according to a second exemplary embodiment of the disclosure.

[0017] Fig. 8 is a perspective view of a carton formed from the blank of Fig. 7.

[0018] Fig. 9 is a plan view of a blank for forming a carton according to a third exemplary embodiment of the disclosure.

[0019] Fig. 10 is a perspective view of a carton formed from the blank of Fig. 9.

[0020] Corresponding parts are designated by corresponding reference numbers throughout the drawings.

DETAILED DESCRIPTION OF THE EXEMPLARY EMBODIMENTS

[0021] The present disclosure generally relates to cartons (e.g., carriers) with features for containing and facilitating dispensing products or articles such as hardware products or automotive products, e.g., oil filters, air filters, etc. The cartons described herein can contain other types of products, e.g., food products or non-food products, without departing from the disclosure. In this specification, the terms “inner,” “interior,” “outer,” “exterior,” “lower,” “bottom,” “upper,” and “top” indicate orientations determined in relation to fully erected and upright cartons.

[0022] As described herein, cartons may be formed by multiple overlapping panels, end flaps, and/or other portions of blanks. Such panels, end flaps, and/or other portions of the blanks can be designated in relative terms to one another, e.g., “first”, “second”, “third”, etc., in sequential or non-sequential reference, without departing from the disclosure.

[0023] Fig. 1 is a plan view of an exterior surface 12 of a blank, generally indicated at 11, used to form a carton 13 (Fig. 10) according to a first exemplary embodiment of the disclosure. The carton 13 can be used to hold a product such as a hardware product, an automotive product such as an oil filter, air filter, etc., or other consumer product, e.g., charcoal briquettes, to name a few, in an interior 15 of the carton 13. The carton 13 can hold other types of articles or products without departing from the disclosure.

[0024] In the illustrated embodiment, the blank 11 has a longitudinal axis L1 and a lateral axis L2. The blank 11 includes a plurality of panels, which include a first side panel 21 foldably connected to a front panel 23 at a lateral fold line 25, a second side panel 27 foldably connected to the front panel 23 at a lateral fold line 29, and a back panel 31 foldably connected to the second side panel 27 at a lateral fold line 33. An attachment flap 35 can be foldably connected to the first side panel 21 at a lateral fold line 37.

[0025] The blank 11 can also include a plurality of lower corner portions foldably connected to respective panels of the plurality of panels of the blank 11. As shown, a first lower corner portion 43 is foldably connected to the first side panel 21 at an oblique fold line 39 and is foldably connected to the front panel 23 at an oblique fold line 41. The oblique fold lines 39, 41 converge at a point of

intersection with the lateral fold line 25, and the first lower corner portion 43 is at least partially defined between the oblique fold line 39, 31.

[0026] A second lower corner portion 49, as shown, is foldably connected to the front panel 23 at an oblique fold line 45 and to the second side panel 27 at an oblique fold line 47. The oblique fold lines 45, 47 converge at a point of intersection with the lateral fold line 29 to at least partially define the second lower corner portion 49 between the oblique fold lines 45, 47. As also shown, the lateral fold line 29 bisects the second lower corner portion 49 to define respective first and second sections 51, 53 that are foldably connected at the fold line 29. In this regard, the first section 51 of the lower corner portion 49 is foldably connected to the front panel 23 at the oblique fold line 45, and the second section 53 of the second lower corner portion 49 is foldably connected to the second side panel 27 at the oblique fold line 47.

[0027] Still referring to Fig. 1, a third lower corner portion 59 is foldably connected to the second side panel 27 at an oblique fold line 55, and the third lower corner portion 59 is foldably connected to the back panel 31 at an oblique fold line 57. The oblique fold lines 57, 59 converge at a point of intersection with the lateral fold line 33, and the lower corner portion 59 is at least partially defined between the oblique fold lines 57, 59.

[0028] As also shown, an interior lower corner section 63 is foldably connected to the back panel 31 at an oblique fold line 61.

[0029] As shown in Fig. 1, a fourth lower corner portion 73 is foldably connected to the attachment flap 35 at an oblique fold line 67 and is foldably connected to the first side panel 21 at an oblique fold line 69. The oblique fold lines 67, 69 converge at a point of intersection with the lateral fold line 37, and the fourth lower corner portion 73 is at least partially defined between the oblique fold lines 67, 69. The lateral fold line 37 can bisect the lower corner portion 73 to define respective first and second sections 65, 71 that are foldably connected at the fold line 37.

[0030] As described further herein, the first section 65 of the lower corner portion 73 is an exterior section 65 for overlapping, e.g., at least partial face-to-face contact, with the interior lower corner section 63 when the carton 13 is formed from the blank 11.

[0031] In this regard, the lower corner portion 43 is positioned between the first side panel 21 and the front panel 23, the lower corner portion 49 is positioned between the front panel 23 and the second side panel 27, the lower corner portion 59 is positioned between the second side panel 27 and the back panel 31, and the lower corner portion 73 is positioned between the back panel 31 and the first side panel 12.

[0032] In an alternative embodiment, the fourth lower corner portion 73 can include the interior lower corner section 63, or the section 63 can be omitted without departing from the disclosure.

[0033] As also shown, the oblique fold lines 69, 39, 41, 45 can have endpoints that are spaced above respective bottom edges of the first side panel 21 and the front panel 23. In this regard, a common or substantially uninterrupted bottom portion 75 of the respective first side panel 21 and the front panel 23 can be defined between the lateral fold lines 37, 29. Similarly, the oblique fold lines 47, 55, 57, 61 can have lower endpoints that are spaced above respective bottom edges of the respective second side panel 27 and the back panel 31 such that a common or substantially uninterrupted bottom portion 77 of the second side panel 27 and the back panel 31 can be defined between the lateral fold line 29 and a free edge of the back panel 31. In one embodiment, the respective lower corner portions 43, 49, 59, 73 can include respective portions of the respective common bottom portions 75, 77.

[0034] A first plurality of spaced lateral fold lines 125, as shown, can be disposed on one or both of the common bottom portions 75, 77 and can also be disposed on a bottom portion of the attachment flap 35.

[0035] A first bottom reinforcement panel 81, as shown, is foldably connected to the first side panel 21 and the front panel 23 at respective portions of a longitudinal fold line 85 such that the first bottom reinforcement panel 81 is foldably connected to the common bottom portion 75 of the first side panel 21 and the front panel 23. Similarly, a second bottom reinforcement panel 83 is foldably connected to the common bottom portion 77 of the second side panel 27 and the back panel 31 at a respective portion of the fold line 85.

[0036] Further, a second plurality of spaced lateral fold lines 127 can be disposed on one or both of the bottom reinforcement panels 81, 83. It will be understood that one or both of the pluralities of fold lines 125, 127, or any one or more individual fold line thereof, can be provided in a different number, arrangement, orientation (e.g., an oblique orientation) or other configuration or dimension without departing from the disclosure.

[0037] With continued reference to Fig. 1, a first bottom end flap 87 is foldably connected to the first bottom reinforcement panel 81 at a longitudinal fold line 89 and a second bottom end flap 91 is foldably connected to the second bottom reinforcement panel 83 at a longitudinal fold line 93 such that the bottom end flaps 87, 91 are disposed along a bottom marginal portion of the blank 11. A longitudinal fold line 95 can bisect the bottom end flap 87 into a first section 97 foldably connected to the bottom reinforcement panel 81 at the fold line 89, and a second section 99 foldably connected to the first section 97 at the fold line 95. In the illustrated embodiment, a pair of extension flaps 101, 103, as shown, are foldably connected to the second bottom end flap 91 at respective lateral fold lines 105, 107.

[0038] In the illustrated embodiment, a first side top end flap 109 is foldably connected to the first side panel 21 at a respective portion of a longitudinal fold line 117, and a front top end flap 111 is foldably connected to the front panel 23 at a respective portion of the fold line 117. The front top end flap 111 has a generally square or orthogonal configuration including generally orthogonal corners 112, 114, 116, 118.

[0039] As also shown, a second side top end flap 113 is foldably connected to the second side panel 27 at a respective portion of the fold line 117, and a back top end flap 115 is foldably connected to the back panel 31 at a respective portion of the fold line 117. In this regard, the top end flaps 109, 111, 113, 115 are disposed along a top marginal portion of the blank 11.

[0040] The blank 11/carton 13 formed therefrom can also include closure or locking features that include a locking tab 119 foldably connected to the front top end flap 111 at a longitudinal fold line 121, and which is for at least partial insertion through a cut 123 that interrupts the fold line 117 adjacent the back top end flap 115. In an alternative embodiment, the blank 11/carton 13 can be devoid of top end flaps or closure features without departing from the disclosure.

[0041] One or more of the panels, flaps, or other features of the blank 11 can have a different shape, dimension, arrangement, or configuration without departing from the disclosure. For example, in an alternative configuration of the blank 11, a coating can be provided on both the interior surface 14 (Fig. 2) and the exterior surface 12 of the blank 11.

[0042] Referring additionally to Figs. 2 and 3, formation of the carton 13 from the blank 11 according to one exemplary embodiment of the disclosure will be described. As shown in Fig. 2, the blank 11 can be positioned with the exterior surface 12 facing down, e.g., such that an interior surface 14 thereof is facing up, and the second bottom reinforcement panel 83 can be folded upwardly at a respective portion of the fold line 85 in the direction of the arrow A1 such that the bottom reinforcement panel 83 is in at least partial face-to-face contact with respective portions of the second side panel 27 and the back panel 31, e.g., the bottom portion 77, and such that the second bottom end flap 91 is also carried into at least partial face-to-face contact with respective portions of the second side panel 27, the back panel 31, and the lower corner portion 59.

[0043] Simultaneously or thereafter, the first bottom reinforcement panel 81 can be folded at a respective portion of the fold line 85 in the direction of the arrow A2 and into at least partial face-to-face contact with the respective portions of the first side panel 21 and the front panel 23, e.g., the bottom portion 75, and the folded first bottom end flap 87 can be carried into overlapping relation with respective portions of the first side panel 21, the front panel 23, and the lower corner portion 43, e.g. such that the first section 97 is in at least partial face-to-face contact with respective portions of the first side panel 21, the front panel 23, and the lower corner portion 43.

[0044] As shown in Fig. 3, the second section 99 of the first bottom end flap 87 can be engaged, for example, by a machine finger, pincer, or other engagement structure, such that the exterior surface of the second section 99 is folded at the fold line 95 in the direction of the arrow A3 into at least partial face-to-face contact with the exterior surface of the first section 97.

[0045] Thereafter, the second side panel 27 can be folded at the fold line 29 in the direction of the arrow A4 and into at least partial face-to-face contact with the front panel 23, and the back panel 31 can thereby be carried into at least partial face-to-face contact with the first side panel 21. To maintain such an arrangement, the attachment flap 35 can be folded at the fold line 37 into at least partial face-to-face contact with the back panel 31, and can be attached thereto with an adhesive such as glue G (Fig. 1). The exterior surface of the second bottom end flap 91 can also be provided with a region of glue G such that the exterior surface of the second bottom end flap 91 can be adhered to the interior surface of the second section 99 of the first bottom end flap 87.

[0046] With reference to Fig. 4, in a first or collapsed configuration of the carton 13, a user or machine part can grasp the carton 13 proximate the fold lines 29, 37 and apply compressive forces F thereto such that the carton 13 expands toward a second or erected configuration in which the second side panel 27 and the back panel 31 are urged away from the first side panel 21 and the front panel 23 to define the interior 15 of the carton 13.

[0047] During such expansion of the carton 13 toward the erected configuration, the pluralities of spaced lateral fold lines 125 on the respective bottom reinforcement panels 81, 83 and the plurality of spaced lateral fold lines 127 on the respective bottom portions 75, 77 (and a bottom portion 78 of the attachment flap 35) provide for flexible reconfiguration thereof to form a round bottom 129 (e.g., circular, rounded or generally round) of the carton 13, e.g., such that the rounded bottom 129 of the carton 13 has a substantially circular cross-sectional profile when viewed from below. It will be understood that the carton bottom 129 can have a different cross-sectional profile that includes one or more curved portions or rounded portions, for example, ovoid, elliptical, semi-circular, etc.

[0048] Further, as the carton 13 is expanded to the erected configuration, the panels 21, 23, 27, 31 and/or the lower corner portions 43, 49, 59, 73 can urge the second bottom end flap 91 downwardly at the fold line 93 in the direction of the arrow A5 such that the second section 99 of the first bottom end flap 87, which is adhered or otherwise attached thereto, is urged to fold upwardly/outwardly at the fold line 95 in the direction of the arrow A6. Such movement of the second section 99 of the first bottom end flap 87 draws the first section 97 to fold downwardly at the fold line 89 and outwardly toward a planar alignment with the second section 99.

[0049] It will be understood that the downward folding of the second bottom end flap 91 at the fold line 93 can be facilitated by upward folding of the extension flaps 101, 103 at the respective fold lines 105, 107 to provide smooth, e.g., relatively low friction, surfaces that can minimize frictional resistance with interior surfaces of one or more the panels 21, 23, 27, 31 and/or the lower corner portions 43, 49, 59, 73 as the bottom end flap 91 moves downwardly. The free edges of the bottom reinforcement panels 81, 83 can provide an engagement edge or stop for the downward movement of the bottom end flaps 87, 91.

[0050] In this regard, the overlapped bottom end flaps 87, 91 provide a bottom panel 92 that forms a closed configuration of the generally rounded carton bottom 129, and which can be formed through squeezing or by compressing on opposing portions of the carton 13 by a user. Such an easily reconfigurable arrangement, e.g., an at least partially automatic rearrangement of the carton bottom 129, of the carton 13 allows the carton 13 to be easily transitioned between the collapsed configuration (Fig. 4), e.g., for transport or storage, and the erected configuration (Fig. 6) in which the interior 15 is provided to receive one or more articles therein.

[0051] In the erected configuration of the carton 13, the panels 21, 23, 27, 31 and the lower corner portions 43, 49, 53, 73 are arranged to surround or circumscribe the circular/round bottom end flaps 87, 91/bottom panel 92.

[0052] As shown in Figs. 5 and 6, the carton 13 is provided with the generally round carton bottom 129 and a generally rectangular top or square top 131 formed by at least the substantially orthogonal arrangement of respective upper portions of the front panel 23 and the first side panel 21 at the fold line 25 to define a first upper corner portion 133 between the panels 21, 23 with an orthogonal configuration, the substantially orthogonal arrangement of respective upper portions of the front panel 23 and the second side panel 27 at the fold line 29 to define a second upper corner portion 135 between the panels 23, 27 with an orthogonal configuration, the substantially orthogonal arrangement of respective upper portions of the second side panel 27 and the back panel 31 at the fold line 33 to define a third upper corner portion 137 between the panels 27, 31 with an orthogonal configuration, and the substantially orthogonal arrangement of respective upper portions of the back panel 31 and the first side panel 21/attachment flap 35 at the fold line 37 to define a fourth upper corner portion 139 between the panels 21, 31 with an orthogonal configuration.

[0053] The generally square top 131 of the carton 13 can be provided in a closed configuration by downward folding of the top end flaps 109, 113 at respective portions of the fold line 117 in the direction of the respective arrows A7, A8, the downward folding of the top end flap 115 into at least partial face-to-face contact with the top end flaps 109, 113 at a respective portion of the fold line 117 in the direction of the arrow A9, and downward folding of the top end flap 111 at a respective portion of the fold line 117 in the direction of the arrow A10 and into at least partial face-to-face contact with

the top end flap 115. As shown, the arrangement of the upper corner portions 133, 135, 137, 139 generally corresponds to, e.g., conforms to, the corners 112, 114, 116, 118 of the top end flap 111.

[0054] Such a closed configuration of the top 131 of the carton 13 can be maintained with locking features, for example, at least partial folding of the locking tab 119 at the fold line 121 and at least partial insertion through the cut 123. It will be understood that the carton top 131 can be provided in a different shape, arrangement, or configuration without departing from the disclosure. For example, the carton 13 can be provided with a configuration that tapers toward a top thereof, or panels or flaps of the carton 13 can be provided with tapered or angled configurations to provide additional shaped features of the carton 13.

[0055] It will be further understood that the carton top 131 can be provided with or without locking features, and which can have a different configuration than described herein without departing from the disclosure. For example, the top end flaps 109, 111, 113, 115 can be attached to one another with an adhesive such as glue, and/or can be provided with a zipper closure or other dispensing feature, etc., without departing from the disclosure.

[0056] Still referring to Figs. 5 and 6, the lower corner portion 43 extends from the rounded carton bottom 129 to the upper corner portion 133, the lower corner portion 49 extends from the rounded carton bottom 129 to the upper corner portion 135, the lower corner portion 59 extends from the rounded carton bottom 129 to the upper corner portion 137, and the lower corner portion 73 extends from the rounded carton bottom 129 to the upper corner portion 139.

[0057] In this regard, the upper corner portion 133 and the lower corner portion 43 together form a first corner C1 of the carton 13, the upper corner portion 135 and the lower corner portion 49 together form a second corner C2 of the carton 13, the upper former portion 137 and the lower corner portion 59 together form a third corner C3 of the carton 13 and the upper corner portion 139 and the lower corner portion 73 together form a fourth corner C4 of the carton 13. The corners C1, C2, C3, C4 thus extend from the square carton top 131 to the rounded carton bottom 129 of the carton 13.

[0058] As described herein, the lower corner portions 43, 49, 59, 73 provide respective regions of transition along the carton 13 from the rounded carton bottom 129 to the square carton top 131. Such transition is facilitated by the generally spaced arrangement of the respective fold lines 39, 41; 45, 47; 55, 57; 61/67, 69 at respective bottom regions thereof that are spaced above and accommodate the curvature of the rounded carton bottom 129. The respective fold lines 39, 41; 45, 47; 55, 57; 61/67, 69 converge as they extend upwardly to intersect the respective fold lines 25, 29, 33, 37 to form the respective upper corner portions 133, 135, 137, 139.

[0059] As illustrated, the lower corner portions 43, 49, 59, 73 can have an at least partially curved or rounded configuration, though the corner features can have other configurations, e.g., chamfered or obliquely-angled or beveled, without departing from the disclosure.

[0060] In this regard, the generally rounded carton bottom 129 can be configured to accommodate a generally round article, e.g., a hardware article, household article such as a charcoal briquette, or automotive article such as an air filter or oil filter, in the interior 15 thereof, and the square carton top 131 is provided with a closure configuration via the top end flaps 109, 111, 113, 115 and optional locking features.

[0061] Such a versatile arrangement of the carton 13, e.g., having an asymmetrical top and bottom, can obviate concerns over some carton arrangements with a generally rounded bottom, e.g., a carton arrangement that lacks the transition features of the lower corner portions 43, 49, 59, 73, such that a rounded top is also provided that can involve the application of, for example, specialized closure features, e.g., removable plastic lids, fitments, etc. In addition, the arrangement of the carton top 131 is such that the top end flap 111 provides an easily visible surface that can be used as a billboard, e.g., a region of the carton 13 upon which printed graphics or other indicia related to a product or retailer can be provided. Furthermore, the carton 13 described herein is provided with the square carton top 131 such that a carton 13 is provided with enhanced strength for one or more additional cartons 13 or other containers that are vertically stacked thereupon.

[0062] Referring additionally to Fig. 7, a blank 211 for forming a carton 213 is illustrated according to a second exemplary embodiment of the disclosure. The blank 211 and the carton 213 formed therefrom can have one or more features that are substantially similar to those of the blank 11 and the carton 13, and like or similar features are designated with like or similar reference numbers.

[0063] As shown, the blank 211 is provided with at least one opening 220 in one or more of the panels 21, 23, 27, 31, one or more openings 222 in one or both of the bottom portions 75, 77, one or more openings 224 in one or both of the bottom reinforcement panels 81, 83, one or more openings 226 in the first bottom end flap 87, and one or more openings 228 in the second bottom end flap 91. It will be understood that the blank 211 can include a different number, arrangement, or configuration of openings without departing from the disclosure.

[0064] Referring additionally to Fig. 8, the carton 213 can be formed from the blank 211, in one embodiment, in the manner described above with respect to the carton 13. The openings 207, 209, 211, 213, 215 can provide, for example, ventilation to one or more articles held in the carton 213. In one embodiment, the openings 207, 209, 211, 213, 215 can provide for visibility of an article held the carton 213. In another embodiment, the openings 207, 209, 211, 213, 215 can provide for drainage or for the escape of evaporated fluids from an article held in the carton 213.

[0065] Turning to Fig. 9, a blank 311 for forming a carton 313 is illustrated according to a third exemplary embodiment of the disclosure. The blank 311 and the carton 313 formed therefrom can have one or more features that are substantially similar to those of the blanks 11, 211 and the cartons 13, 213, and like or similar features are designated with like or similar reference numbers.

[0066] As shown, the blank 311 is provided with a line of weakening 320, for example a longitudinal tear line or perforated line, extending across respective upper portions of the panels 21, 23, 27, 31 and the attachment flap 35. In this regard, the tear line 320 and the features of the blank 311 above the tear line 320 (e.g., upper portions of the respective panes 21, 23, 27, 31 and the attachment flap 35, the top end flaps 109, 111, 113, 115, and the locking flap 119) are dispenser features for forming a dispenser 322 of the carton 313.

[0067] Referring additionally to Fig. 10, the carton 313 can be formed from the blank 311, in one embodiment, in the manner described above with respect to the cartons 13, 213. As shown, the dispenser 322 is at least partially separable from the remainder of the carton 313 at the line of weakening 320, for example, for ease of retrieval of one or more articles disposed in the carton 313 by a customer or for visible display in a retail space. In one embodiment, the line of weakening 320 can be arranged such that the carton top 131 is hingably attached to the remainder of the carton 313.

[0068] The blanks according to the present disclosure can be, for example, formed from coated paperboard and similar materials. For example, the interior and/or exterior sides of the blanks can be coated with a clay coating. The clay coating may then be printed over with product, advertising, price coding, and other information or images. The blanks may then be coated with a varnish to protect any information printed on the blank. The blanks may also be coated with, for example, a moisture barrier layer, on either or both sides of the blanks. In accordance with the above-described embodiments, the blank may be constructed of paperboard of a caliper such that it is heavier and more rigid than ordinary paper. The blanks can also be constructed of other materials, such as cardboard, hard paper, or any other material having properties suitable for enabling the cartons, to function at least generally as described above. The blanks can also be laminated to or coated with one or more sheet-like materials at selected panels or panel sections.

[0069] In accordance with the above-described embodiments of the present disclosure, a fold line can be any substantially linear, although not necessarily straight, form of weakening that facilitates folding therealong. More specifically, but not for the purpose of narrowing the scope of the present disclosure, fold lines include: a score line, such as lines formed with a blunt scoring knife, or the like, which creates a crushed portion in the material along the desired line of weakness; a cut that extends partially into a material along the desired line of weakness, and/or a series of cuts that extend partially into and/or completely through the material along the desired line of weakness; and various combinations of these features.

[0070] As an example, a tear line can include: a slit that extends partially into the material along the desired line of weakness, and/or a series of spaced apart slits that extend partially into and/or completely through the material along the desired line of weakness, or various combinations of these features. As a more specific example, one type tear line is in the form of a series of spaced apart slits that extend completely through the material, with adjacent slits being spaced apart slightly so that a nick (e.g., a small somewhat bridging-like piece of the material) is defined between the adjacent slits for typically temporarily connecting the material across the tear line. The nicks are broken during tearing along the tear line. The nicks typically are a relatively small percentage of the tear line, and alternatively the nicks can be omitted from or torn in a tear line such that the tear line is a continuous cut line. That is, it is within the scope of the present disclosure for each of the spaced apart slits to be replaced with a continuous slit, a continuous score, or the like. For example, a cut line can be a continuous slit or could be wider than a slit without departing from the present disclosure. Also, a tear line can be a series of cut scores passing completely, or partially, through the material, that are separated by nicks.

[0071] The term “glue” is intended to encompass all manner of adhesives commonly used to secure carton panels in place.

[0072] The foregoing description of the disclosure illustrates and describes various exemplary embodiments. Various additions, modifications, changes, etc., could be made to the exemplary embodiments without departing from the spirit and scope of the disclosure. It is intended that all matter contained in the above description or shown in the accompanying drawings shall be interpreted as illustrative and not in a limiting sense. Additionally, the disclosure shows and describes only selected embodiments of the disclosure, but the disclosure is capable of use in various other combinations, modifications, and environments and is capable of changes or modifications within the scope of the inventive concept as expressed herein, commensurate with the above teachings, and/or within the skill or knowledge of the relevant art. Furthermore, certain features and characteristics of each embodiment may be selectively interchanged and applied to other illustrated and non-illustrated embodiments of the disclosure.

WHAT IS CLAIMED IS:

1. A carton for holding at least one article, the carton comprising:
 - a plurality of panels extending at least partially around an interior of the carton, the plurality of panels comprising a front panel, a back panel, and at least one side panel; and
 - at least one top end flap foldably connected to a panel of the plurality of panels, the at least one top end flap is for forming a closed top of the carton;
 - at least one bottom end flap foldably connected to a panel of the plurality of panels, the at least one bottom end flap is for forming a closed bottom of the carton;
 - the closed top of the carton has a square configuration and the closed bottom has a round configuration.
2. The carton of claim 1, further comprising at least one corner extending from the closed top of the carton to the closed bottom of the carton, the at least one corner has a respective upper corner portion and a respective lower corner portion disposed between respective adjacent panels of the plurality of panels.
3. The carton of claim 2, wherein the upper corner portion has an orthogonal configuration and the lower corner portion has a curved configuration.
4. The carton of claim 3, wherein adjacent panels of the plurality of panels are foldably connected at a respective at least one fold line.
5. The carton of claim 4, wherein the at least one fold line comprises a lateral fold line intersecting a pair of oblique fold lines.
6. The carton of claim 5, wherein the upper corner portion is defined by the respective adjacent panels and the lateral fold line.
7. The carton of claim 6, wherein the lower corner portion is at least partially defined between the pair of oblique fold lines.
8. The carton of claim 7, wherein at least a portion of the lower corner portion is planar.
9. The carton of claim 3, wherein the at least one top end flap has a plurality of orthogonal corners, the at least one corner of the carton comprises a plurality of corners, each upper corner portion of a respective corner of the plurality of corners corresponds to a respective orthogonal corner of the plurality of orthogonal corners of the at least one top end flap.

10. The carton of claim 9, wherein the at least one bottom end flap has a round configuration, the plurality of panels and the plurality of lower corner portions together circumscribe the at least one bottom end flap.
11. The carton of claim 10, wherein the plurality of panels further comprises a bottom reinforcement panel foldably connected to at least two of the front side panel, the back side panel, and the at least one side panel, the bottom reinforcement panel provides a stop edge for engaging the at least one bottom end flap.
12. The carton of claim 10, wherein the at least one bottom end flap comprises a first section foldably connected to a second section.
13. The carton of claim 12, wherein the at least one bottom end flap is a first bottom end flap, and the carton further comprises a second bottom end flap foldably connected to a panel of the plurality of panels and at least one extension flap foldably connected to the second bottom end flap for engaging an interior surface of at least one panel of the plurality of panels.
14. The carton of claim 7, wherein the at least one side panel is a first side panel and the plurality of panels further comprises a second side panel, the at least one corner comprises a first corner between the front panel and the first side panel and formed by a first upper corner portion and a first lower corner portion, the at least one corner further comprises a second corner between the first side panel and the back panel and formed by a second upper corner portion and a second lower corner portion, the at least one corner further comprises a third corner between the back panel and the second side and formed by a third upper corner portion and a third lower corner portion, and the at least one corner further comprises a fourth corner between the second side panel and the front panel and formed by a fourth upper corner portion and a fourth lower corner portion.
15. The carton of claim 9, wherein the carton further comprises a dispenser comprising an upper portion of each panel of the plurality of panels and the at least one top end flap.
16. The carton of claim 15, wherein the dispenser is separably connected to the remainder of the carton at a tear line.
17. The carton of claim 9, wherein the at least one bottom end flap comprises at least one opening.
18. The carton of claim 17, wherein at least one panel of the plurality of panels comprises an opening.

19. A blank for forming a carton for holding at least one article, the blank comprising:
- a plurality of panels for extending at least partially around an interior of the carton formed from the blank, the plurality of panels comprising a front panel, a back panel, and at least one side panel; and
 - at least one top end flap foldably connected to a panel of the plurality of panels, the at least one top end flap is for forming a closed top of the carton formed from the blank; and
 - at least one bottom end flap foldably connected to a panel of the plurality of panels, the at least one second end flap is for forming a closed bottom of the carton formed from the blank such that the closed top of the carton formed from the blank has a square configuration and the closed bottom formed from the blank has a round configuration.
20. The blank of claim 19, wherein adjacent panels of the plurality of panels are foldably connected at a respective at least one fold line, the at least one fold line comprises a lateral fold line intersecting a pair of oblique fold lines.
21. The blank of claim 20, wherein an upper corner portion for at least partially forming at least one corner of the carton formed from the blank is defined by the respective adjacent panels and the lateral fold line, and a lower corner portion is at least partially defined between the pair of oblique fold lines for at least partially forming at least one corner of the carton formed from the blank.
22. The blank of claim 19, wherein the at least one top end flap has a plurality of orthogonal corners and the at least one bottom end flap has a round configuration.
23. The blank of claim 22, wherein the plurality of panels further comprises a bottom reinforcement panel foldably connected to at least two of the front side panel, the back side panel, and the at least one side panel.
24. The blank of claim 22, wherein the at least one bottom end flap comprises a first section foldably connected to a second section.
25. The blank of claim 24, wherein the at least one bottom end flap is a first bottom end flap, and the carton further comprises a second bottom end flap foldably connected to a panel of the plurality of panels and at least one extension flap foldably connected to the second bottom end flap for engaging an interior surface of at least one panel of the plurality of panels when the carton is formed from the blank.

26. The blank of claim 22, wherein the blank further comprises a dispenser comprising an upper portion of each panel of the plurality of panels and the at least one top end flap, the dispenser is separably connected to the remainder of the blank at a tear line.

27. The blank of claim 22, wherein the at least one bottom end flap comprises at least one opening, and at least one panel of the plurality of panels comprises an opening.

28. A method of forming a carton for holding at least one article, the method comprising:

obtaining a blank comprising a plurality of panels comprising a front panel, a back panel, and at least one side panel, the blank further comprising at least one top end flap foldably connected to a panel of the plurality of panels, and at least one bottom end flap foldably connected to a panel of the plurality of panels;

folding the plurality of panels at least partially around an interior of the carton; and

folding the at least one top end flap to form a closed top of the carton and folding the at least one bottom end flap to form a closed bottom of the carton such that the closed top of the carton has a square configuration and the closed bottom has a round configuration.

29. The method of claim 28, further comprising at least one corner extending from the closed top of the carton to the closed bottom of the carton, the at least one corner has a respective upper corner portion and a respective lower corner portion disposed between respective adjacent panels of the plurality of panels.

30. The method of claim 29, wherein the upper corner portion has an orthogonal configuration and the lower corner portion has a curved configuration.

31. The method of claim 30, wherein adjacent panels of the plurality of panels are foldably connected at a respective at least one fold line, the at least one fold line comprises a lateral fold line intersecting a pair of oblique fold lines.

32. The method of claim 31, wherein the upper corner portion is defined by the respective adjacent panels and the lateral fold line, and the lower corner portion is at least partially defined between the pair of oblique fold lines.

33. The method of claim 32, wherein at least a portion of the lower corner portion is planar.

34. The method of claim 30, wherein the at least one top end flap has a plurality of orthogonal corners, the at least one corner of the carton comprises a plurality of corners, each upper corner portion of a respective corner of the plurality of corners corresponds to a respective orthogonal corner of the plurality of orthogonal corners of the at least one top end flap.

35. The method of claim 34, wherein the at least one bottom end flap has a round configuration, the plurality of panels and the plurality of lower corner portions together circumscribe the at least one bottom end flap.

36. The method of claim 35, wherein the plurality of panels further comprises a bottom reinforcement panel foldably connected to at least two of the front side panel, the back side panel, and the at least one side panel, the bottom reinforcement panel provides a stop edge for engaging the at least one bottom end flap.

37. The method of claim 35, wherein the at least one bottom end flap is a first bottom end flap comprising a first section foldably connected to a second section, and the carton further comprises a second bottom end flap foldably connected to a panel of the plurality of panels and at least one extension flap foldably connected to the second bottom end flap for engaging an interior surface of at least one panel of the plurality of panels.

38. The method of claim 32, wherein the at least one side panel is a first side panel and the plurality of panels further comprises a second side panel, the at least one corner comprises a first corner between the front panel and the first side panel and formed by a first upper corner portion and a first lower corner portion, the at least one corner further comprises a second corner between the first side panel and the back panel and formed by a second upper corner portion and a second lower corner portion, the at least one corner further comprises a third corner between the back panel and the second side and formed by a third upper corner portion and a third lower corner portion, and the at least one corner further comprises a fourth corner between the second side panel and the front panel and formed by a fourth upper corner portion and a fourth lower corner portion.

39. The method of claim 34, wherein the carton further comprises a dispenser comprising an upper portion of each panel of the plurality of panels and the at least one top end flap, the dispenser is separably connected to the remainder of the carton at a tear line.

40. The method of claim 34, wherein the at least one bottom end flap comprises at least one opening, and at least one panel of the plurality of panels comprises an opening.

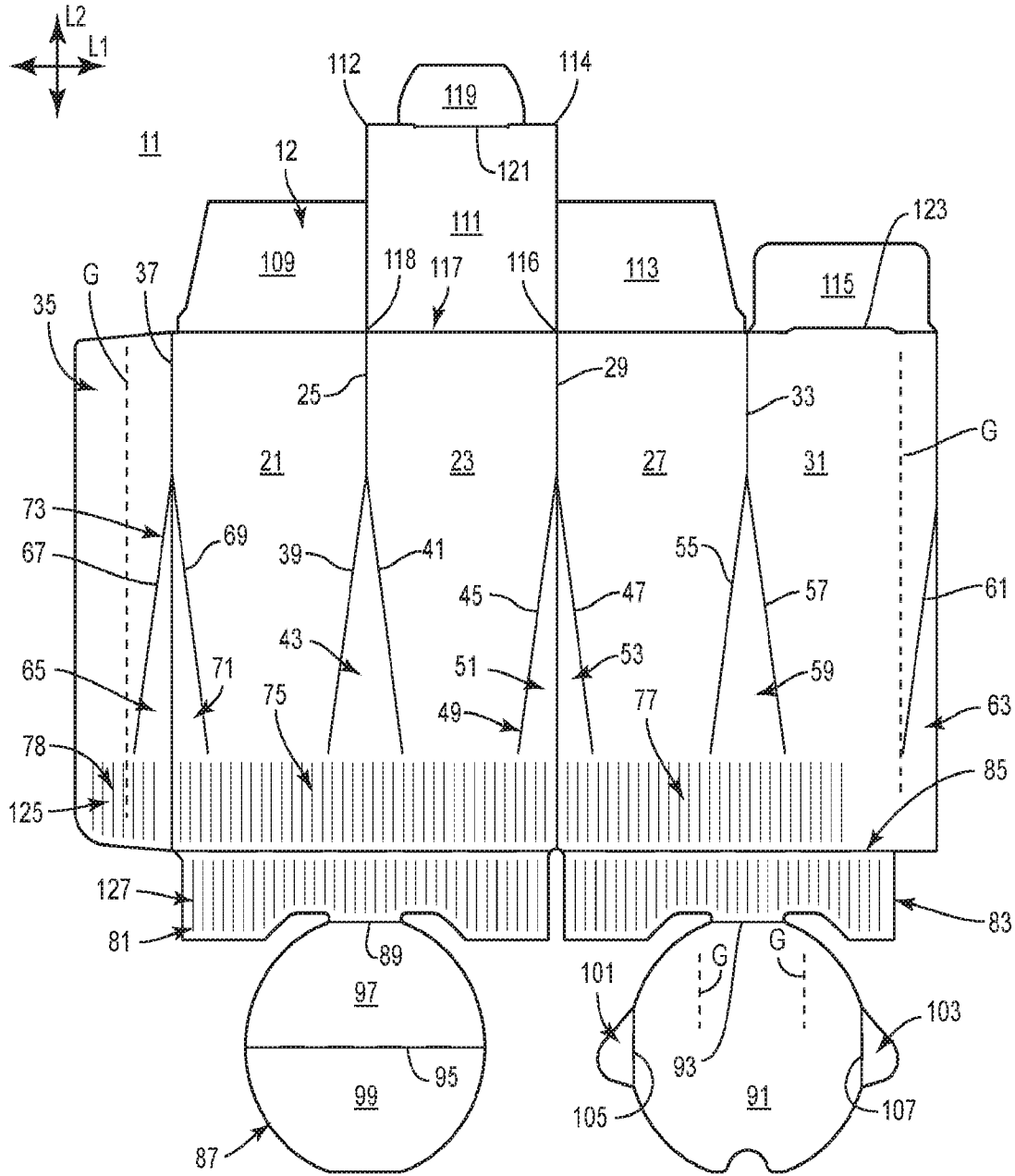

FIG. 1

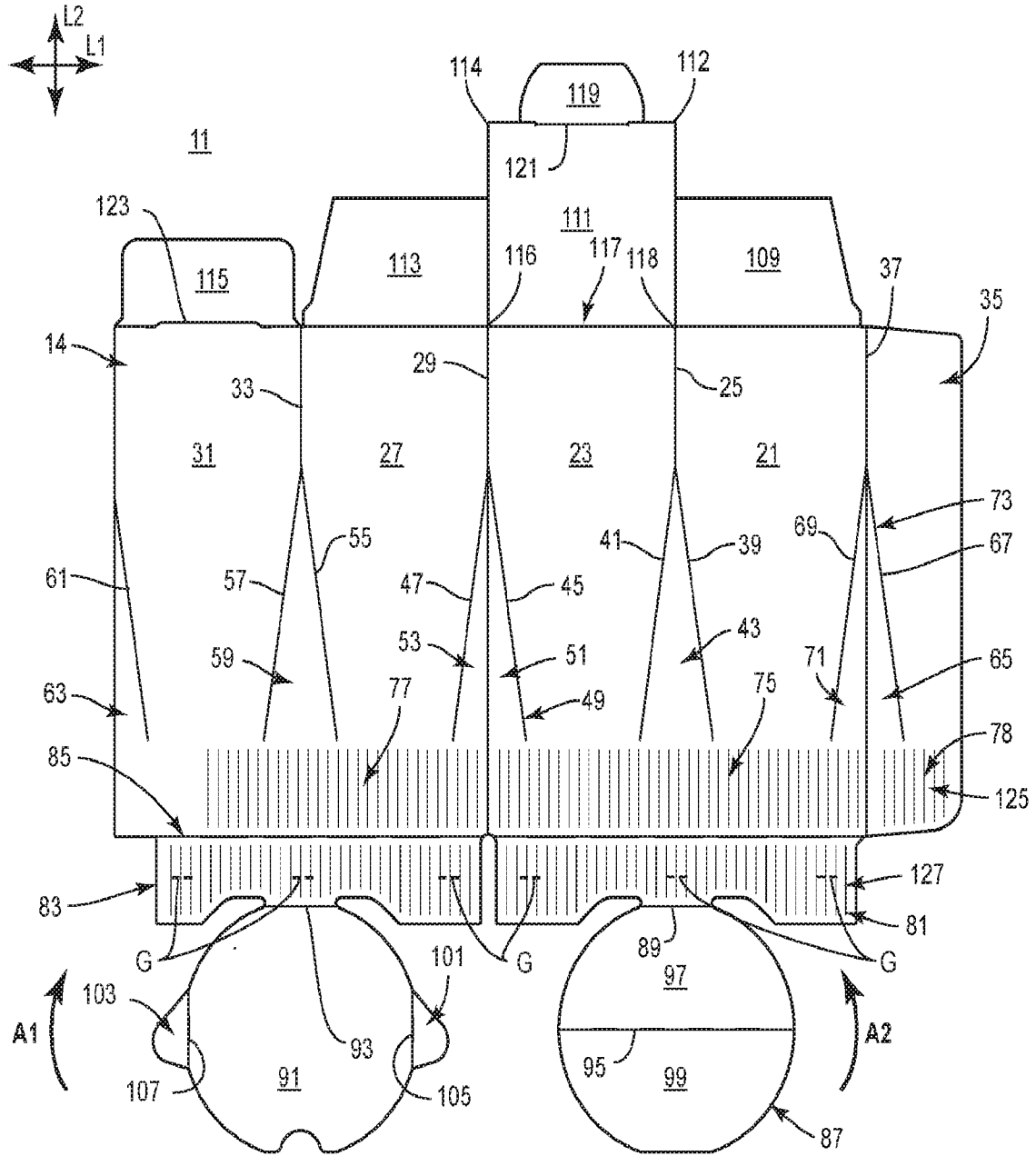

FIG. 2

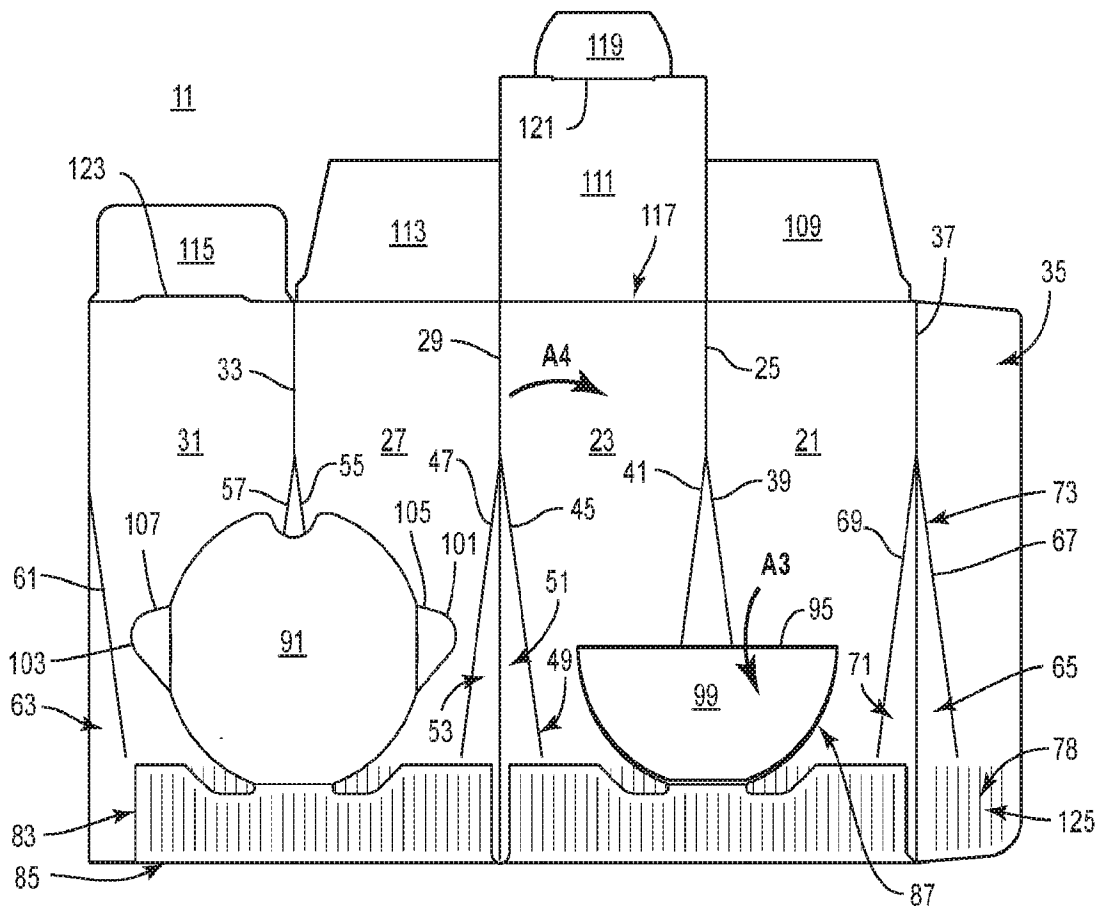

FIG. 3

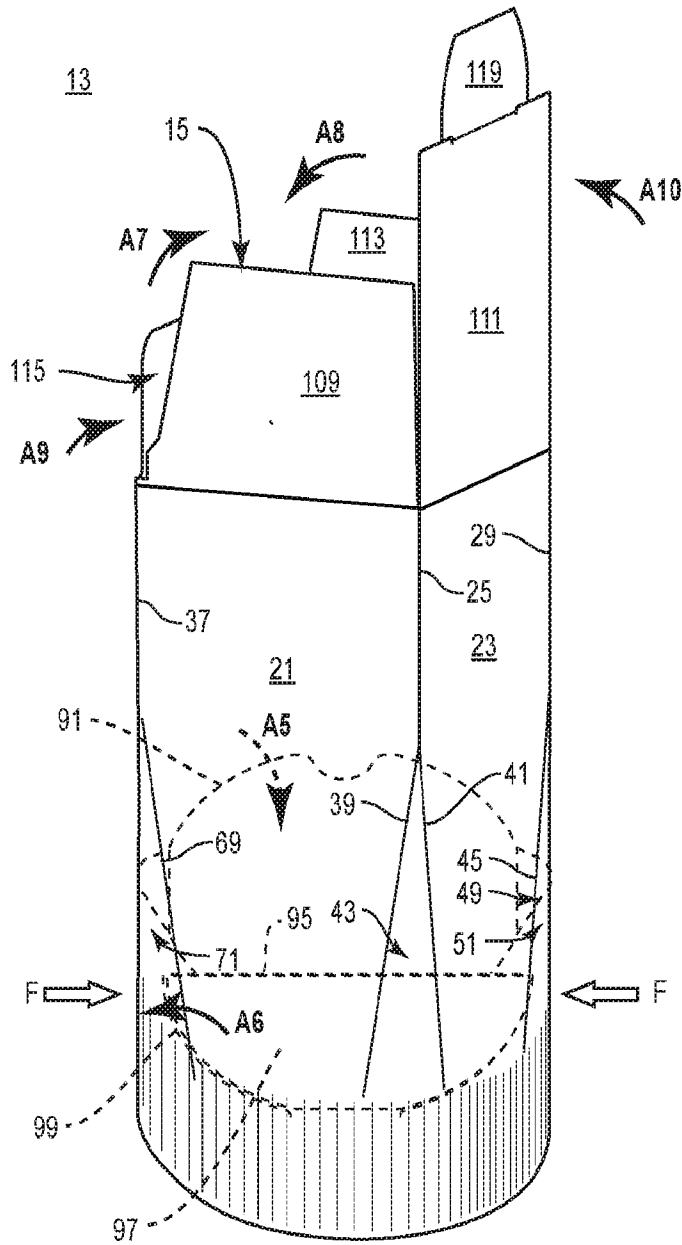

FIG. 4

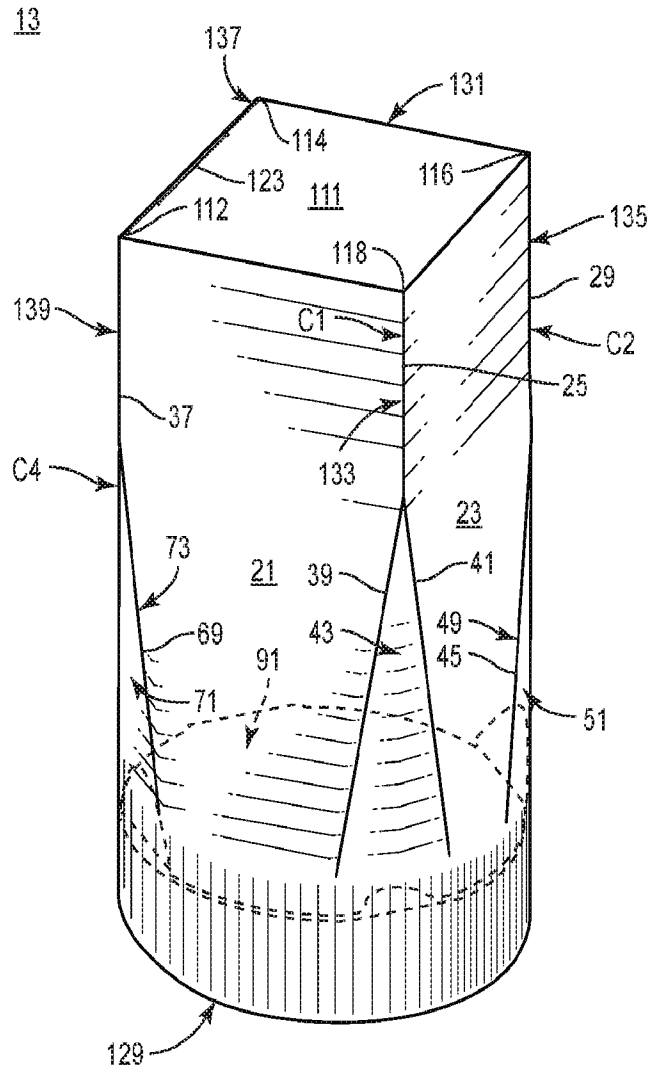

FIG. 5

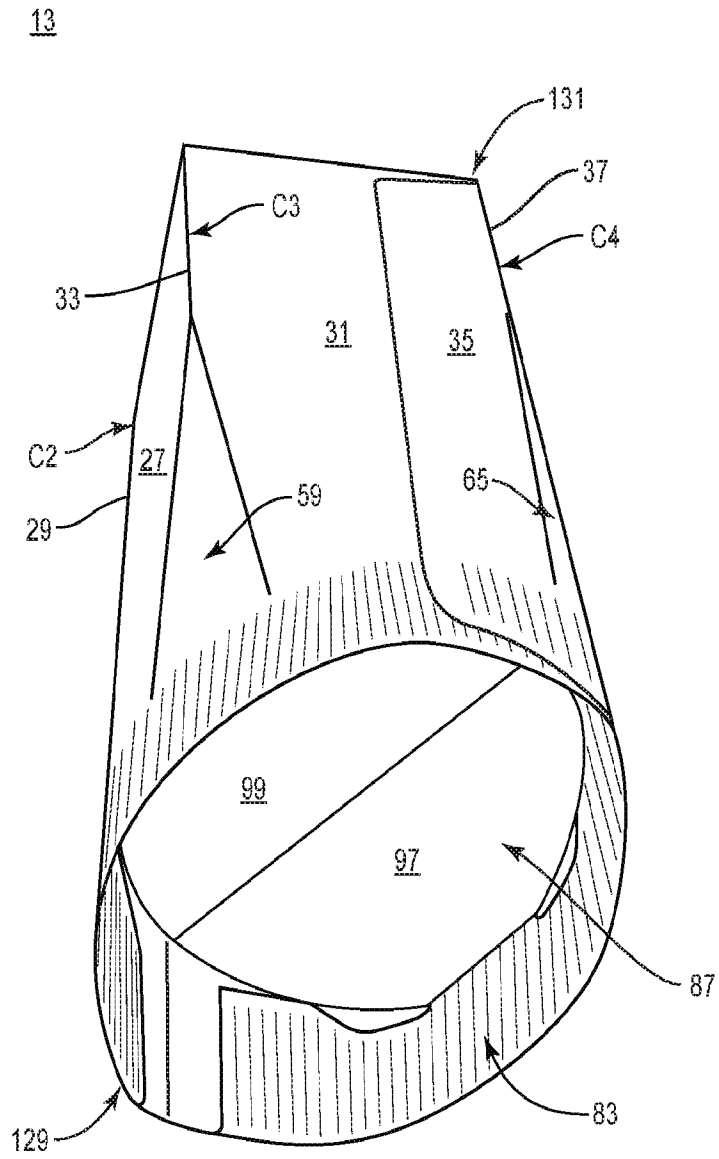

FIG. 6

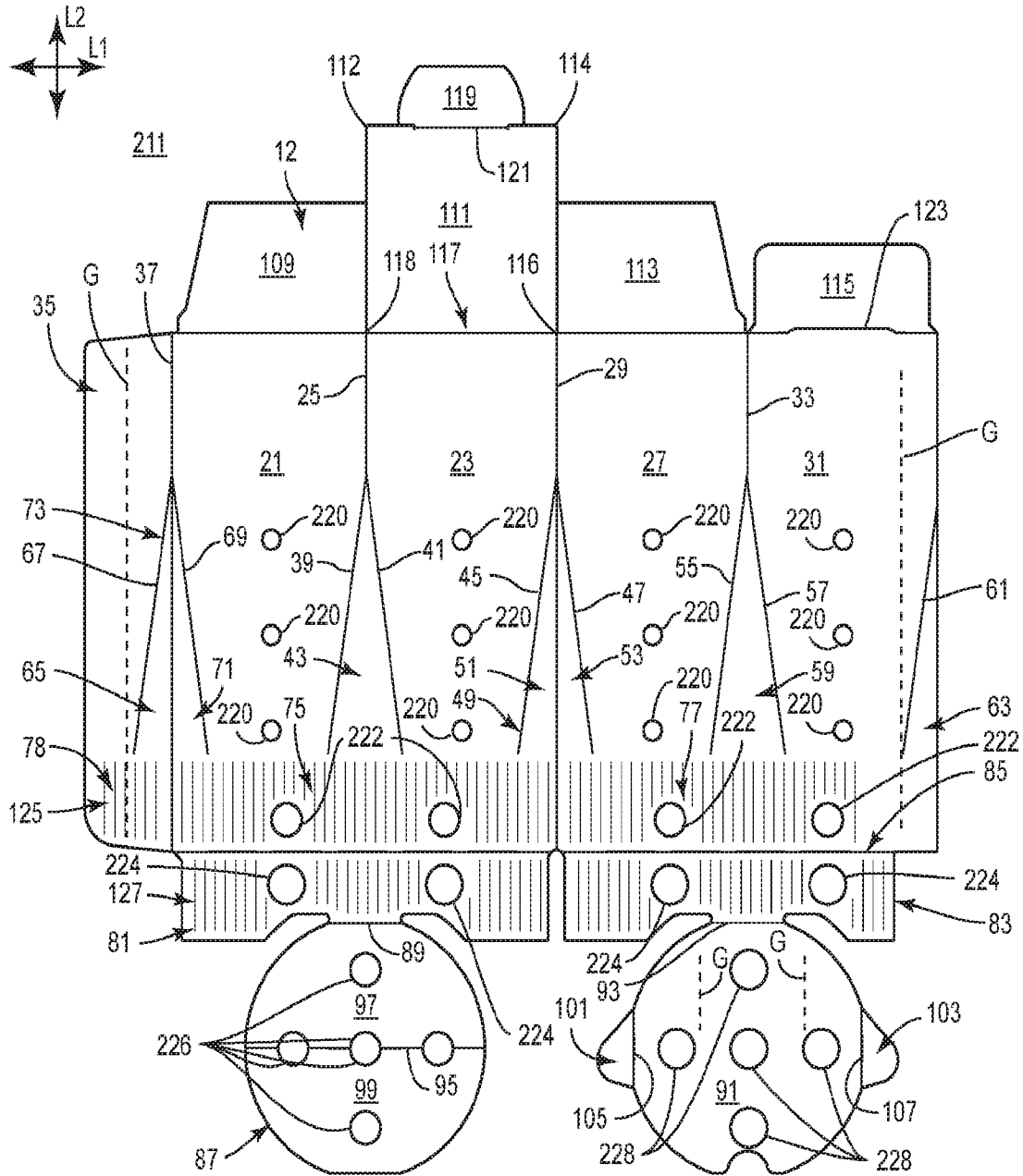

FIG. 7

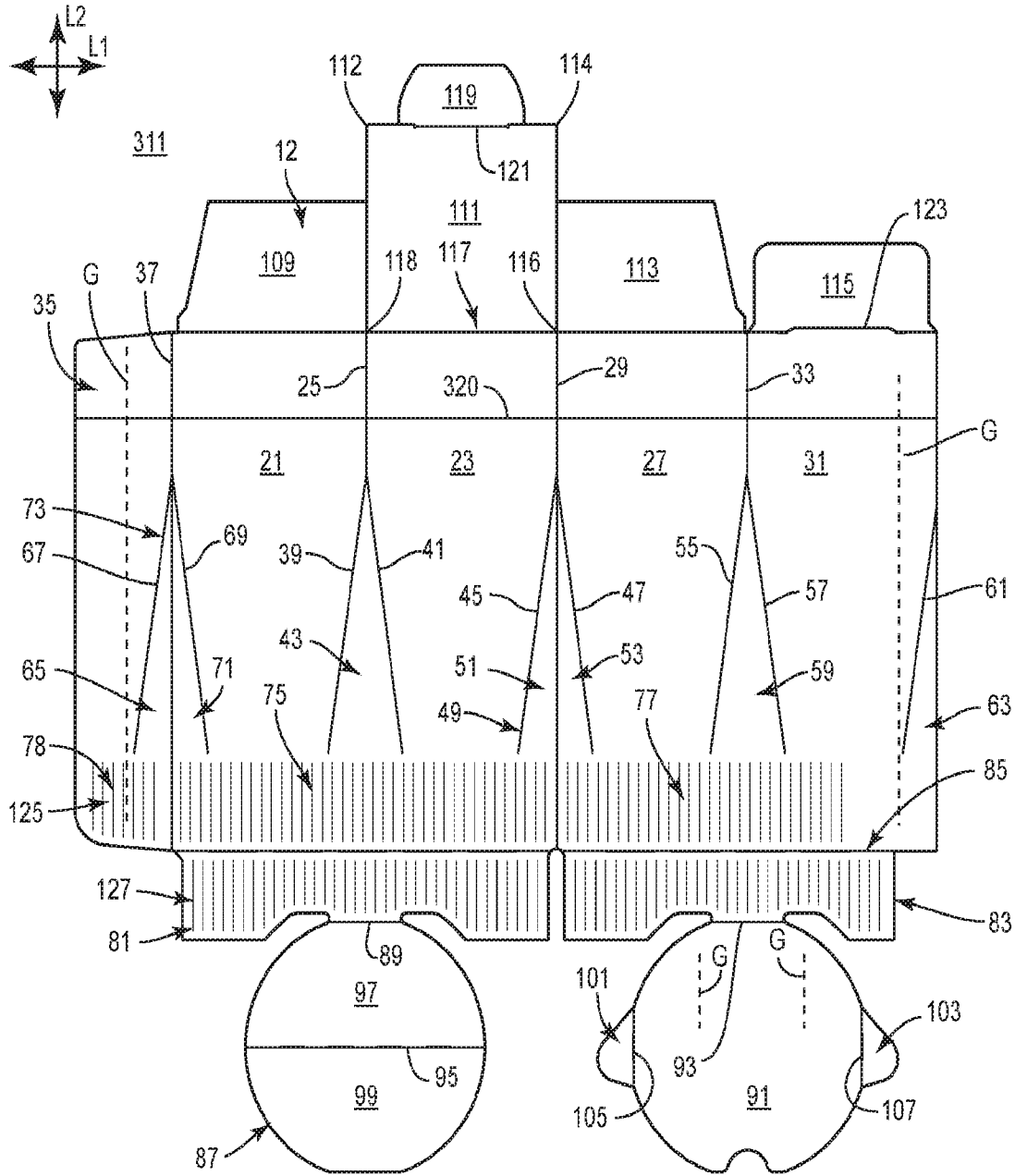

FIG. 9

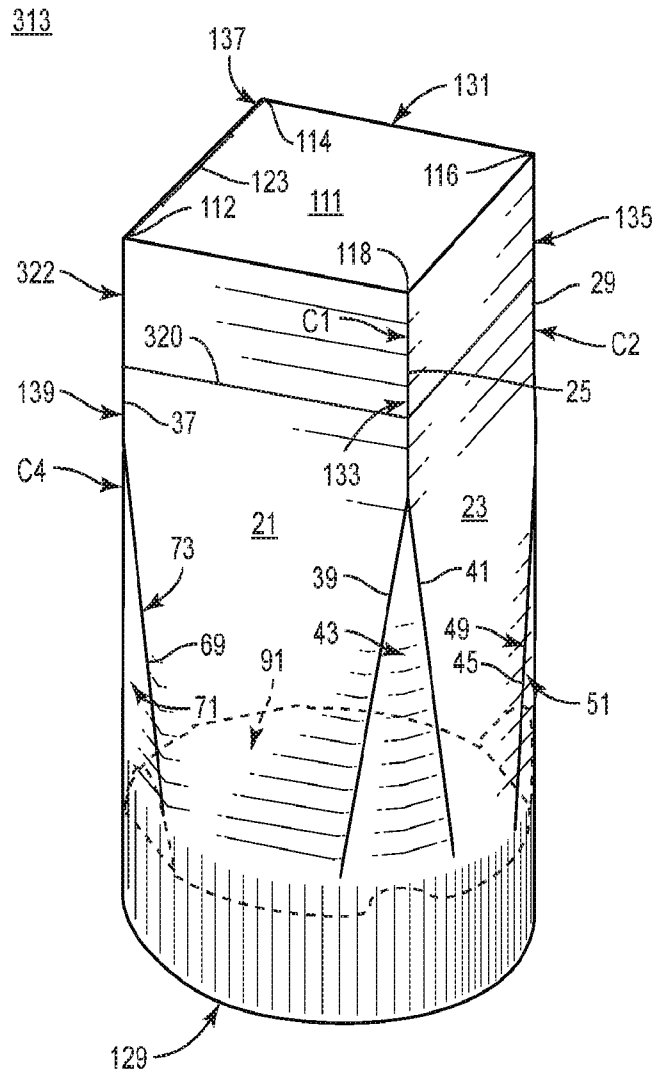

FIG. 10

A. CLASSIFICATION OF SUBJECT MATTER**B65D 5/02(2006.01)i, B65D 5/42(2006.01)i, B65D 5/50(2006.01)i, B65D 5/72(2006.01)i**

According to International Patent Classification (IPC) or to both national classification and IPC

B. FIELDS SEARCHED

Minimum documentation searched (classification system followed by classification symbols)

B65D 5/02; B31B 3/00; B65D 3/20; B65D 5/00; B65D 5/06; B65D 5/36; B65D 5/54; B65D 6/02; B65D 5/42; B65D 5/50; B65D 5/72

Documentation searched other than minimum documentation to the extent that such documents are included in the fields searched

Korean utility models and applications for utility models

Japanese utility models and applications for utility models

Electronic data base consulted during the international search (name of data base and, where practicable, search terms used)

eKOMPASS(KIPO internal) & Keywords: carton, top end flap, bottom end flap, square, round, corner, oblique fold line

C. DOCUMENTS CONSIDERED TO BE RELEVANT

Category*	Citation of document, with indication, where appropriate, of the relevant passages	Relevant to claim No.
X	JP 2010-013141 A (HEIWA PACKAGE K.K. et al.) 21 January 2010 paragraphs [0028]-[0045] and figures 1-6	1-12, 14, 19-24, 28-36, 38
Y		13, 15-18, 25-27, 37, 39-40
Y	US 2013-0193196 A1 (HALLAM et al.) 01 August 2013 paragraphs [0032]-[0035], [0045], [0050] and figures 1, 4	13, 25, 37
Y	JP 2016-204043 A (TOPPAN PRINTING CO., LTD.) 08 December 2016 paragraphs [0020]-[0027] and figures 1-6	15-16, 26, 39
Y	WO 2014-045066 A1 (MEATOLOGY LIMITED) 27 March 2014 page 8, lines 20-22 and figures 1-3	17-18, 27, 40
X	KR 20-0438755 Y1 (JUNG, JIN HWAN) 06 March 2008 claim 1 and figures 1-7	1, 19, 28

 Further documents are listed in the continuation of Box C. See patent family annex.

* Special categories of cited documents:

"A" document defining the general state of the art which is not considered to be of particular relevance

"D" document cited by the applicant in the international application

"E" earlier application or patent but published on or after the international filing date

"L" document which may throw doubts on priority claim(s) or which is cited to establish the publication date of another citation or other special reason (as specified)

"O" document referring to an oral disclosure, use, exhibition or other means

"P" document published prior to the international filing date but later than the priority date claimed

"T" later document published after the international filing date or priority date and not in conflict with the application but cited to understand the principle or theory underlying the invention

"X" document of particular relevance; the claimed invention cannot be considered novel or cannot be considered to involve an inventive step when the document is taken alone

"Y" document of particular relevance; the claimed invention cannot be considered to involve an inventive step when the document is combined with one or more other such documents, such combination being obvious to a person skilled in the art

"&" document member of the same patent family

Date of the actual completion of the international search

27 July 2020 (27.07.2020)

Date of mailing of the international search report

27 July 2020 (27.07.2020)

Name and mailing address of the ISA/KR

International Application Division

Korean Intellectual Property Office

189 Cheongsa-ro, Seo-gu, Daejeon, 35208, Republic of Korea



Facsimile No. +82-42-481-8578

Authorized officer

BAHNG SEUNG HOON

Telephone No. +82-42-481-5560



INTERNATIONAL SEARCH REPORT

Information on patent family members

International application No.

PCT/US2020/027580

Patent document cited in search report	Publication date	Patent family member(s)	Publication date
JP 2010-013141 A	21/01/2010	None	
US 2013-0193196 A1	01/08/2013	GB 2496358 A GB 2496358 B US 9090371 B2 WO 2012-020256 A1	08/05/2013 08/10/2014 28/07/2015 16/02/2012
JP 2016-204043 A	08/12/2016	None	
WO 2014-045066 A1	27/03/2014	CA 2885938 A1 DK 2909091 T3 EP 2909091 A1 EP 2909091 B1 ES 2613485 T3 PL 2909091 T3 US 10287082 B2 US 2015-0225161 A1	27/03/2014 13/03/2017 26/08/2015 30/11/2016 24/05/2017 31/07/2017 14/05/2019 13/08/2015
KR 20-0438755 Y1	06/03/2008	None	