

(No Model.)

2 Sheets—Sheet 1.

C. N. BLOOD.
STUMP EXTRACTOR.

No. 523,100.

Patented July 17, 1894.

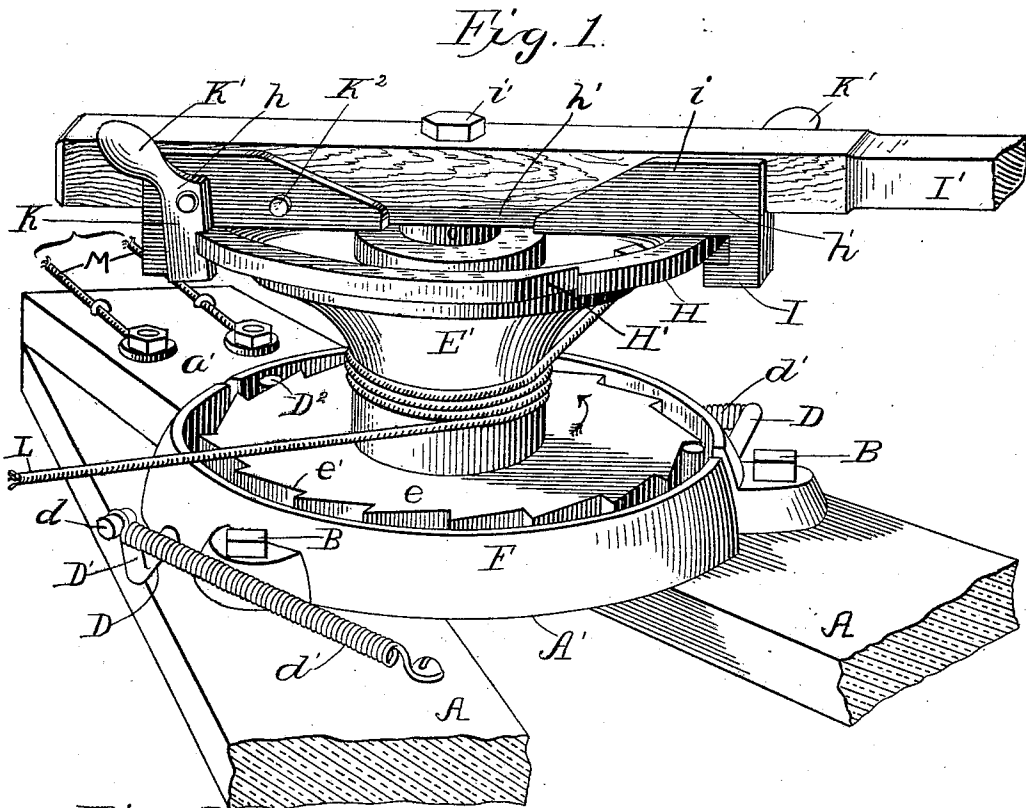
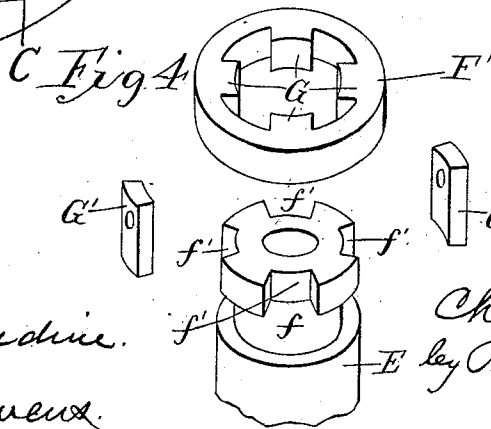
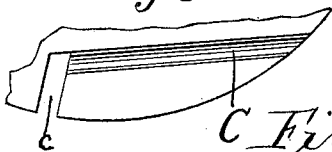

Fig 5



Witnesses
Alfred Burdine.
J. B. Owens.

Inventor
Charles N. Blood
 by *Rhisa S. [unclear]*
 his Attorney

C. N. BLOOD. STUMP EXTRACTOR.

No. 523,100.

Patented July 17, 1894.

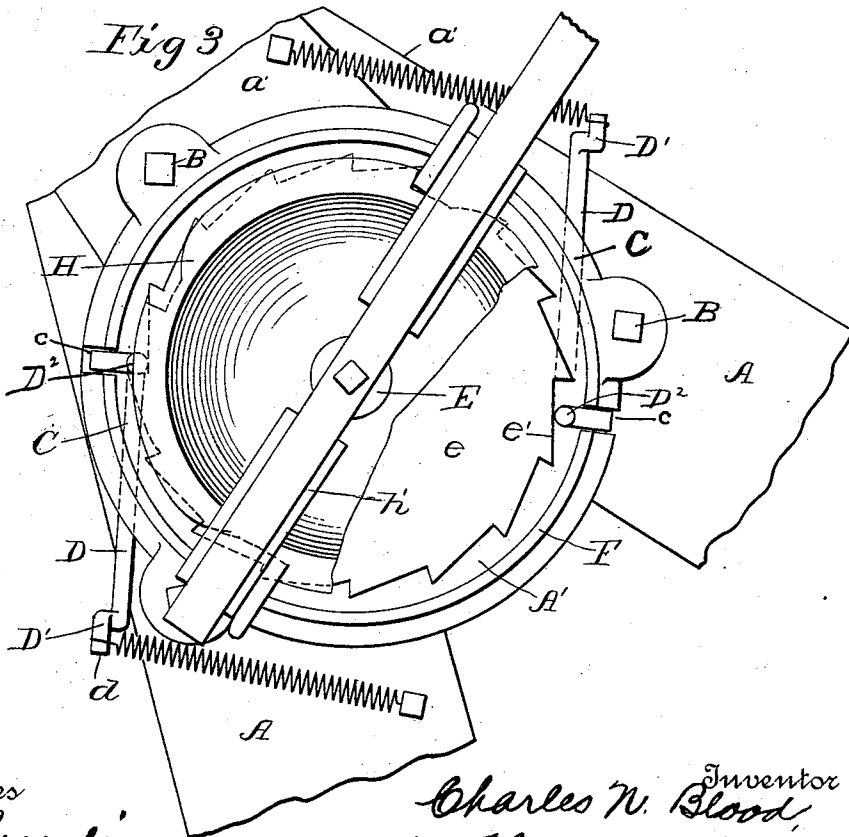
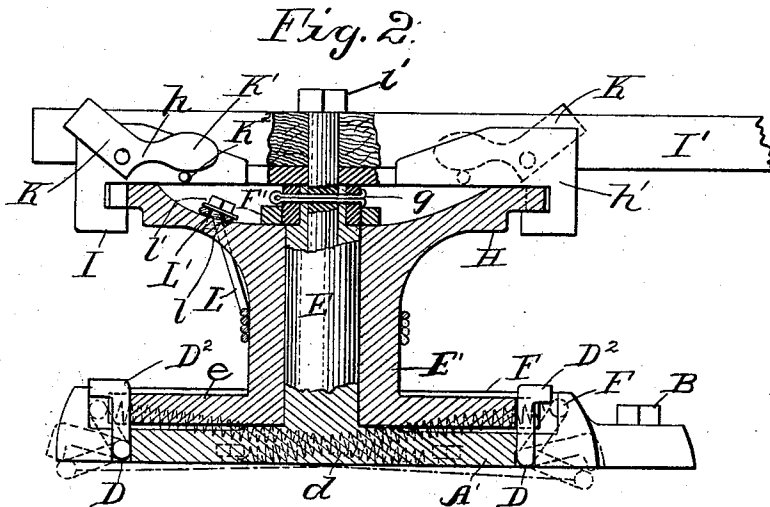

Witnesses
C. E. Budine.
J. S. Owens.

Inventor
Charles N. Blood,
 by *Phuatt & Sons*
 his Attorney

UNITED STATES PATENT OFFICE.

CHARLES N. BLOOD, OF ANAMOSA, IOWA.

STUMP-EXTRACTOR.

SPECIFICATION forming part of Letters Patent No. 523,100, dated July 17, 1894.

Application filed January 25, 1894. Serial No. 497,972. (No model.)

To all whom it may concern:

Be it known that I, CHARLES N. BLOOD, a citizen of the United States, residing at Anamosa, in the county of Jones and State of Iowa, have invented certain new and useful Improvements in Stump-Extractors; and I do declare the following to be a full, clear, and exact description of the invention, such as will enable others skilled in the art to which it appertains to make and use the same, reference being had to the accompanying drawings, and to the letters of reference marked thereon, which form a part of this specification.

My invention relates to an improvement in that class of stump extractors wherein a horse-power windlass and cable are employed; and my principal object is to so improve this class of extractors as to permit the work to be performed with greater facility.

A further object is to improve upon the mechanism shown and described in my prior patent, No. 508,401, granted November 14, 1893.

To these ends the invention consists in certain improved features of construction and combination and arrangement of parts, all of which will now be fully described and finally embodied in the claims.

Referring to the accompanying drawings: Figure 1 represents a perspective view of the complete machine; Fig. 2 a vertical section; Fig. 3, a plan view; Fig. 4, a detail, and Fig. 5, a plan view of a portion of the base plate.

The reference letter A indicates the base timbers upon which it is usual to mount my improvements, and these may consist of any suitable arrangement.

A' indicates the base plate of my machine and this is provided with an offset or arm *a'* and with an annular flange F extending vertically from its upper face. The plate A' is arranged upon the base timbers and is held in place by bolts B which pass through lugs formed on the plate A' and through the arm *a'*.

Formed in the bottom of the plate A' are two grooves C, which are arranged opposite each other, and near the circular portion. These grooves, C, extend from the edge of the disk inwardly for a distance equal to about one-third the diameter of the disk. From this point they turn outwardly, as at *c*, and pro-

ceed to the edge, this latter portion extending in a direction from the center of the disk, and the groove is deepened or enlarged at this point, so as to form a slot extending vertically the entire thickness of the plate.

Arranged within the slots *c* are the pawls D, each of which consists of a round bar D having at its respective ends arms or offsets D' and D². The arm D' is formed on that end of the bar which projects out from the plate A', and extends normally perpendicularly, while the arm D² is arranged to extend normally within the slot *c*, though it is capable of moving outwardly therein.

The arm D' is provided at its end with a wrist pin *d* to which one end of the spiral spring *d'* is attached, the remaining end of the spring being attached to a point on the base timbers which point must be inward from the point D, so that the spring will give said bar a normal tendency to revolve and throw the arm D² in engagement with the teeth *e*.

Formed integral with or rigidly secured to the base plate A', and rising vertically from the center thereof is the standard E, upon which the winding drum E' is mounted. The base flange *e* of the drum has formed in its edge a series of ratchet teeth *e'* and is of a thickness equal to the height of the flange F. By means of this flange the ratchet teeth are protected and the rope or cable prevented from becoming entangled therein. The ratchet teeth *e'* are adapted to co-operate with the arms D² which latter are held yieldingly against said teeth by the action of the springs *d'*.

Thus it will be seen that the bars D and their attached parts operate as spring actuated pawls. The purpose of this peculiar construction is to admit their easy disengagement from the ratchet teeth and to allow them to be held so disengaged for as long as may be desired. This disengaging operation is effected by swinging the arms D' to the left, against the tendency of the spring *d'*, until the said arms lie in the plane below the bar D, or pass the dead-center of the bar. When this position has been attained the springs *d'* will exert their influence in a direction opposite to that in which it is normally exerted thus tending to hold the arms D² out of engagement with the ratchet teeth. When the

pawls are in operative position they will prevent the drum E' from turning back and when they are disengaged from the ratchet teeth the drum will be free to revolve in either direction, thus permitting the unwinding of the cable after it has been wound during the extracting operation.

Referring particularly to Fig. 4; the letter F' indicates a collar or plate, which is arranged upon the upper end of the standard E , and which is adapted to hold the drum in place. An annular groove f is formed in the side of the standard E near the upper end. Short grooves f' extend from the said annular groove f vertically through the upper end of the standard. The collar F' is provided with four radial and inwardly extending lugs G , which are of such a length and size that they may pass freely through the grooves f' , and into the groove f . After the collar F' is seated in the groove f it is turned axially on the standard for a distance sufficient to bring the lugs G and the grooves f' out of vertical alignment, and consequently cause the said grooves 25 or recesses occurring in the collar F' between its lugs G to register with the grooves f' . G' indicates two keys which are of a size equal to that of the grooves f' and which are adapted to be seated within said grooves opposite each other and to have their lower ends pass within the recesses in the collar F' which occur directly under them, a linch pin or screw g being provided which passes through them and through the bolt i' and by which the whole is held in place. From this construction it will be seen that a removable flange or stop is provided for the standard E and by means of which the drum E' may be firmly secured in place, yet capable of removal. The flange 40 H of the upper end of the winding drum E' is provided with four ratchet shaped notches H' formed in its edge, and these notches are designed to co-operate with the gravity pawl of the sweep-seat h' .

The sweep-seat h' consists of a plate of a length equal to the diameter of the flange H and provided at its ends and sides with a downwardly and inwardly extending flange I . This seat is adapted to be mounted upon the flange H , and to have its flanges I embrace the periphery of said flange, H , whereby the seat is steadied during its operation.

I' indicates the sweep which is seated between the vertical portion i of the seat and the two devices, seat h' and the sweep I' are held in place capable of axial movement by means of the vertical bolt or pin i' , which passes through the sweep, and its seat, and into the passage formed in the standard E for its reception.

The pawls h are two in number and are arranged on opposite sides and at either end of the seat h' . Each pawl consists of a portion K pivoted to the sweep-seat at one end and adapted to hang downwardly from said pivot, and to engage with the periphery of the flange H . Formed integral with that end of

the portion K which is pivoted to the seat, and extending upwardly and outwardly from said end is the weighted knob K' , which owing to the influence of its weight tends to throw the portion K inwardly and by this means its engagement with the flange H is insured. To disengage these pawls from the flange H the weighted portion K' is swung inward until it rests upon the stud K^2 projecting out from the sweep-seat and on either side thereof. This operation will cause the portion K to lie in approximately a horizontal plane and consequently out of engagement with the flange H . Owing to the weight of the portion K' this position will be kept until the said portion is moved back to its former position. The operation of this device is shown by dotted lines in the drawings. The purpose of this last described pawl and ratchet mechanism is to permit the sweep to positively engage the drum when moving in a direction which will cause the rope to wind thereon, but to be free to move independently of the drum when the sweep is moved in an opposite direction. When the rope is being removed from the drum it will be necessary to disengage the pawls and their flange entirely.

L , indicates the winding rope or cable which passes through an opening L' in the flange H , and around a stud l formed on the upper face of said flange, a plate and nut l' being provided by which the cable is clamped in place, and secured to the drum. Secured by similar means to the arm a' is a looped cable M , which is adapted to pass over some immovable object in the field and thereby hold the machine while the stump is being extracted.

To use the machine for a stump extractor, it is secured to any convenient immovable object by means of the cable M , and the winding cable L is connected to the stump. Power, usually that of a horse, is applied to the sweep I' , so that the drum will be made to revolve and the cable L wound thereon. By this means the stump is drawn from its position.

Having thus described my invention, what I claim as new, and desire to secure by Letters Patent, is—

1. A stump extractor comprising base timbers, a base plate secured upon the timbers and having a vertical annular flange, and a groove in the nether side extending inwardly from the edge and terminating in an outwardly extending slot, a drum having a flanged base fitted in the space encircled by the said annular flange and toothed on its peripheral edge, means for turning the drum, a bar seated in the said groove and held therein between the base plate and base timbers, one end being turned up and adapted to work in the said slot and engage with the toothed edge of the base flange of the drum, the other end being bent to form a crank, and a spring attached to the said crank to normally hold the inner bent end of the bar in operative relation with the base of the drum and out of op-

erative relation as required, substantially as described.

2. In a stump extractor the combination with a drum having its upper flange provided with teeth in its peripheral edge, of a sweep seat having its outer edge portions embracing the edge portion of the toothed flange of the drum, weighted pawls pivoted to the sweep seat and held in either a pendent or approximately horizontal position by reason of their counterbalanced ends, and a sweep mounted in the said seat, substantially as described.

3. The combination of a shaft or standard adapted to have a drum mounted thereon and provided with an annular groove *f*, and with a series of vertical grooves *f'* extending out-

ward from the groove *f* to the end of the standard or shaft, a ring or collar adapted to pass over the end of the standard, and having a corresponding series of lugs arranged to move in the grooves *f'* and become seated in the groove *f* in which it is turned to bring said lugs and grooves *f'* out of alignment, and a key fitted into the aligning grooves in the collar and standard, to secure the collar in place, substantially as specified.

In testimony whereof I affix my signature in presence of two witnesses.

CHARLES N. BLOOD.

Witnesses:

GEORGE H. BENNETT,
DAVIE W. ELLIS.